

Experimental results of cooking tests in the dry season in a subequatorial country using a box-type solar cooker with an inclined receiving surface fitted with a flat reflector

Abstract

In this work, a box-type solar cooker with an inclined receiving surface with a flat reflector is designed and manufactured with less expensive materials available in the local market. Cooking tests were carried out during the great dry season in the south of Côte d'Ivoire, a subequatorial country, to assess the performance of the system. During these tests, the illumination (E) and temperatures at different places of the solar cooker were measured. The absorber temperature (T_a) rose above 100 ° C, which made it possible to cook eggs and yam stew with fish. The results obtained for these tests are satisfactory and very encouraging because the cooker produced allows sufficient temperatures to be reached for healthy cooking of food.

Keywords: Box-type Solar Cooker, Energy, temperature, absorber.

1. Introduction

To cook food, we usually need gas, electricity, and even wood. As for the latter, a significant portion of the world's population, especially in developing countries, uses it for cooking meals and for heating. Easy to access and inexpensive, financial constraints and reluctance to change established habits are factors that work in its favor, especially when combined with a lack of information on the repercussions of its smoke on the health of the people. lungs. Its cooking is certainly natural, but is not without negative consequences. The use of wood as a means of cooking food is quite devastating for the forest cover, the planet, and for health. In fact, to obtain wood, you have to cut trees. This is damaging the forests. It is one of the causes of deforestation, environmental pollution and global warming [1]. Then, the cooking itself can cause, as mentioned above, significant health problems in the long run. Burning wood releases pollutants that hinder breathing. Worse yet, these pollutants trap some of the air in the lungs, which decreases their oxygen capacity [2]. According to Smith, Mehta and Maeusezahl-Feuz, the use of solid fuels causes 800,000 to 2.4 million premature deaths each year [3].

When it comes to gas, and electricity, these energies are not inexhaustible. Their misuse contributes to the aggravation of the problems of greenhouse gas emissions and their extractions put the planet's resources at risk. To overcome these problems, one of the natural and easy alternatives is obviously the use of solar energy. The Ivory Coast has a significant solar deposit. The daily average sunshine varies between 3 and 5 kWh / m² depending on the region and a sunshine duration of 6 hours [4]. This non-polluting and free energy can be converted into useful energy for cooking food using solar cookers or solar concentrators. Each solar cooker can save a ton of wood per year in sunny regions, and can therefore avoid the release of a large amount of greenhouse gases [5]. It is a promising option capable of being

one of the main sources of energy for the domestic sector [6]. It can be the most environmentally friendly solution for cooking food.

The development and popularization of solar cookers are therefore more than necessary.

To meet these needs, researchers have conducted investigations on the improvement and design of solar cookers. Many solar cookers have been developed in different countries with different sizes [7]. Different authors have also defined and used several parameters to test the performance of solar cookers[8]. Some of them depend on an energy analysis [9, 10,11] and others on an exergy analysis [12, 13, 14, 15]. The variations in loads on the performance of different solar cookers was also discussed. For the first time in 2015 the concept of optimal load range for solar cookers was introduced by Mahavar [8]. This concept is based on an energy analysis. Indeed, the optimal load range is a load range for which each solar cooker has good cooking performance and a reasonably high efficiency. The ultimate goal of all this work is to make solar cookers more malleable and accessible to a large part of the population.

It is therefore in this context that we have built a very small box-type solar cooker that can be transported anywhere with a flat reflector and whose opening surface is inclined to allow better exposure to solar radiation.

In this article, we will present the results of experimental tests carried out on this solar cooker during the dry season in Abidjan, a city located in West Africa.

2. Description of the box-type solar cooker

First, The tilted surface box-type solar cooker consists of two boxes: an outer box and an inner wooden box. The space between the two boxes, including the bottom of the tray, is filled with an insulating material (polystyrene) to reduce heat loss to the outside (Figure 1). It has a double-glazed cover, a reflecting mirror and a galvanized sheet absorber. The matt black painted absorber absorbs solar radiation and transfers its heat to the cooking utensil. Pommels allow the glass surface and the reflector to be fixed to the outer box.

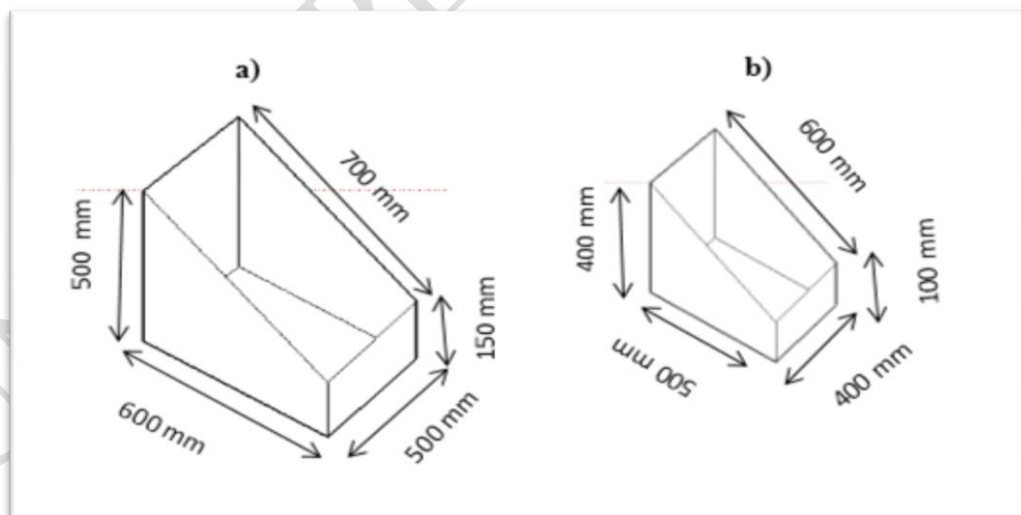

Figure 1: Dimensions of the box type solar cooker with an inclined surface; a) outer box and b) inner box [16].

These hinges are used to orient the reflector when the system is exposed to the sun (Figure 2). Outside of operating times, the reflector is folded down and the cooker is closed. During the period of use of the solar cooker, it is oriented so that the direct solar radiation is perpendicular to its opening surface. This technique allows better capture of solar radiation

and a longer duration of daily use because the operation of the stove can be obtained at sunrise [17].



Figure 2: Photograph of the cooker made with the open reflector.

3. Experimental measurements

The various experimental tests were carried out under natural sunlight at the Laboratory of Fundamental and Applied Physics of the Ecole Normale Supérieure (ENS) of Abidjan. They took place during the great dry season in December 2020. The cooker was installed in a stationary position facing the sun. The control of the thermal behavior of the solar cooker requiring regular monitoring of the temperatures at several points of the cooker during its operation. During each cooking test, the ambient temperature (T_a), the temperature of the absorbent plate (T_p) at the center of its horizontal part, the temperature of the air inside the cooker (T_r) and the internal temperature of the cooker are measured. the kitchen utensil (T_w) used, as well as the solar radiation E . For the measurement of the different temperatures, thermocouples are used. As for the measurement of global solar radiation, it was carried out by an EPPLEY type pyranometer, with a conversion coefficient k equal to $10.41 \text{ mV} / \text{W} / \text{m}^2$ and error on the measured illumination $\pm 10 \text{ W} / \text{m}^2$ (Figure 3) All data is collected every 5 minutes.

The tests focused on cooking eggs and yam stew with fish. These tests were carried out to gauge the limits of the cooker in terms of maximum temperatures reached and its capacity to cook these food products with evaluation of the cooking time.



Figure 3: Photograph of the experimental set-up.

4. Theoretical studies

4.1. Heat exchange between the glass and the absorber (Q_{p,av_2})

The heat exchange (Q_{p,av_2}) between the glass and the absorber is by convection and by radiation.

$$Q_{p,av_2} = (hc_{p-v} + h_{r,p-v}) (T_p + T_v) \quad (1)$$

hc_{p-v} : Coefficient of heat transfer by convection between the glass and the absorber and
 $h_{r,p-v}$: coefficient of heat transfer by radiation between the glass and the absorber given

by:

$$h_{r,p-v} = \frac{\sigma(T_p + T_v)(T_p^2 + T_v^2)}{\frac{1}{\epsilon_p} + \frac{1}{\epsilon_v} - 1} \quad (2)$$

where : T_p : Absorber temperature (K)

T_v : Glass temperature (K);

ϵ_v : Emissivity of the glass;

ϵ_p : Emissivity of the absorber.

To determine the convection coefficient hc_{p-v} , the following correlations are used:

$$Nu_1 + 1.44 \left[1 - \frac{1708(\sin 1.8\beta)^{1.6}}{Ra} \right] \left[1 - \frac{1708}{Ra \cos \beta} \right] + \left[\left(\frac{Ra \cdot \cos \beta}{5830} \right)^{1/3} - 1 \right] \quad [18]$$

β : angle of incidence of the cooker and

Ra : Rayleigh's number

$$Ra = \frac{g(T_p - T_v)L_c^3}{T_{ma} \nu_a \alpha_a} \quad (4)$$

L_c : characteristic length (space between the absorber and the glass);

g : intensity of gravity ($m \cdot s^{-2}$);

α_a : thermal diffusivity of air ($\text{m}^2.\text{s}^{-1}$);

a : the kinematic viscosity of air ($\text{m}^2.\text{s}^{-1}$);

T_{ma} : the average temperature of the air between the absorber and the glass, given by:

$$T_{ma} = \frac{T_p + T_v}{2} \quad \dots \quad (5)$$

$$\text{and } V_a = \frac{\mu_a}{\rho_a} \quad (6)$$

μ_a : dynamic viscosity of air ($\text{kg}.\text{m}^{-1} \text{s}^{-1}$);

ρ_a : density of air ($\text{kg}.\text{m}^{-3}$);

α : thermal diffusivity of air:

$$\alpha = \frac{\lambda_a}{\rho_a C p_a} \quad (7)$$

$C p_a$: heat mass of air at constant pressure ($\text{J}.\text{kg}^{-1} \text{K}^{-1}$);

λ_a : thermal conductivity of air ($\text{W}.\text{m}^{-1} \text{K}^{-1}$);

$$N_u = \frac{h_{c,p-v} . L_c}{\lambda_a} \quad (8)$$

From which we get the convection coefficient:

$$h_{c,p-v} = N_u \frac{\lambda_a}{L_c} \quad (9)$$

Duffie and Beckman have given an empirical relationship due to Kelvin for the calculation of the overall exchange coefficient before U_{av} , with an error of less than $\pm 0,3 \text{W}/\text{m}^2$. [18]

$$U_{av} = \left(\frac{N}{\frac{c}{T_{pm}} \left[\frac{(T_{pm} + T_{am})}{(N+f)} \right]^e} + \frac{1}{h_{c,v-a}} \right)^{-1} + \frac{\sigma (T_{pm} + T_{am}) (T_{pm}^2 + T_{am}^2)}{\frac{1}{\varepsilon_p + 0,00591 N h_{c,v-a}} + \frac{2N+f-1+0,133\varepsilon_p}{\varepsilon_v} - N} \quad (10)$$

U_{av} : Loss coefficient of the front panel ($\text{W}/\text{m}^2.\text{K}$),

N : Number of glass

$$f = (1 + 0.089 h_{c,v-a} - 0.1166 \times h_{c,v-a} \times \varepsilon_p) (1 + 0.07866N), \quad (11)$$

$$h_{c,v-a} = 5,67 + 3,86 \times V_{wind} \quad (12)$$

$C = 520(1 - 0.000051 \beta^2)$ Pour $0^\circ < \beta < 70^\circ$, et pour $70^\circ < \beta < 90^\circ$ On prend $\beta = 70^\circ$,

$$e = 0.43(1 - 100 T_{pm}), \quad (13)$$

(13)

ε_g : Glass emissivity;

T_{pm} : Average plate temperature (K).

4.2. Losses towards the back of the cooker

It is often possible to neglect the losses by convection before that due to conduction within the insulation, so the losses behind the sensor are given by the following formula [19].

$$Q_{p,ar} = \frac{(T_p - T_{is})}{\frac{e_{is}}{\lambda_{is}}} \quad (14)$$

We can thus define the rear loss coefficient U_{ar} such that

$$U_{ar} = \frac{\lambda_{is}}{e_{is}} \quad (15)$$

Where λ is and e_{is} are the thermal conductivity and the back insulation thickness, respectively.

4.3. Losses by the lateral faces

The losses through the side faces of the sensor are given by the formula:

$$Q_{p,lat} = \frac{(T_p - T_{is})}{\frac{e_{islat}}{\lambda_{is}} \frac{A_c}{A_{lat}}} \quad (16)$$

Where: A_c : Sensor surface;

A_{lat} : Surface of the side faces of the sensor;

e_{islat} : Thickness of the insulation on its side faces;

U_{lat} the coefficient of losses by the side faces is defined by:

$$U_{lat} = \frac{\lambda_{is}}{e_{islat}} \frac{A_{lat}}{A_c} \quad (17)$$

4.4. Energy balance of the cooker

If we have the solar irradiance that reaches the earth's surface, then the fraction of solar irradiance absorbed by the absorbent plate (horizontal) after passing through the glazing is calculated using the expression:

$$Q_{abs} = \tau \alpha_p G_t \quad (18)$$

With:

τ : Transmission factor of the glass,

α_p : Absorption factor of the absorber,

G_t : The overall illumination incident on the cooker (W / m^2)

Part of the energy absorbed is transferred to the environment in the form of thermal energy mainly by convection, by radiation and by conduction. The fraction of solar irradiance absorbed Q_{abs} by the absorbent plate is partly recovered by the utensil cooking in the form of heat. We denote it Q_u . However, the solar cooker is subject to thermal losses. These losses will be noted Q_p . So we have :

$$Q_{abs} = Q_u + Q_p \quad (19)$$

In addition we have:

$$Q_p = UL (T_p - T_a) \quad (20)$$

T_p : Absorber temperature (T_p)

UL is the overall loss coefficient defined as being the sum of the front, side and rear loss coefficients.

$$UL = U_{av} + U_{ar} + U_{la} \quad (21)$$

By replacing equation (3) in equation (2), we obtain the expression of the useful energy $Q_u = \tau \alpha_p G_t - UL (T_p - T_a)$ (22)

5. Cooking test results

The cooking tests took place during the dry season precisely in December. During this period, the harmattan, a hot wind from the Sahara, sometimes blows quite strongly, carrying dust and drying out everything in its path. This dust consists of plant particles (herbs, dry flowers, pollen) animal (bird feathers, waste of all kinds).

5.1. Egg cooking test

The egg box test took place on December 15, 2020. The thermal behavior of the solar cooker in several places during its operation was carried out and curves were drawn. Analysis of the temperature curves suggests small disturbances due to the passage of dust clouds. The absorber temperature curve is above the other curves. The greenhouse effect is not negligible because the temperature of the indoor air goes up to 106 ° C when the absorber at 114 ° C (Figure 4). One hour after starting to cook, the cookware is at 60 ° C. An egg has been broken to show its cooked state. This temperature of 60 ° C is not sufficient to cook the eggs (Figure 5.a), so cooking the egg cannot be done at 60 ° C. It probably starts at 82 ° C as indicated by "Solaire cockers international" [20]. After 1 hour 55 minutes of cooking, 86 ° C is reached, the eggs are therefore cooked (figure 5.b). However, we allowed the experiment to continue until the water boiled at 100 ° C at 1:00 p.m. Or 2h35min after the start of the test.

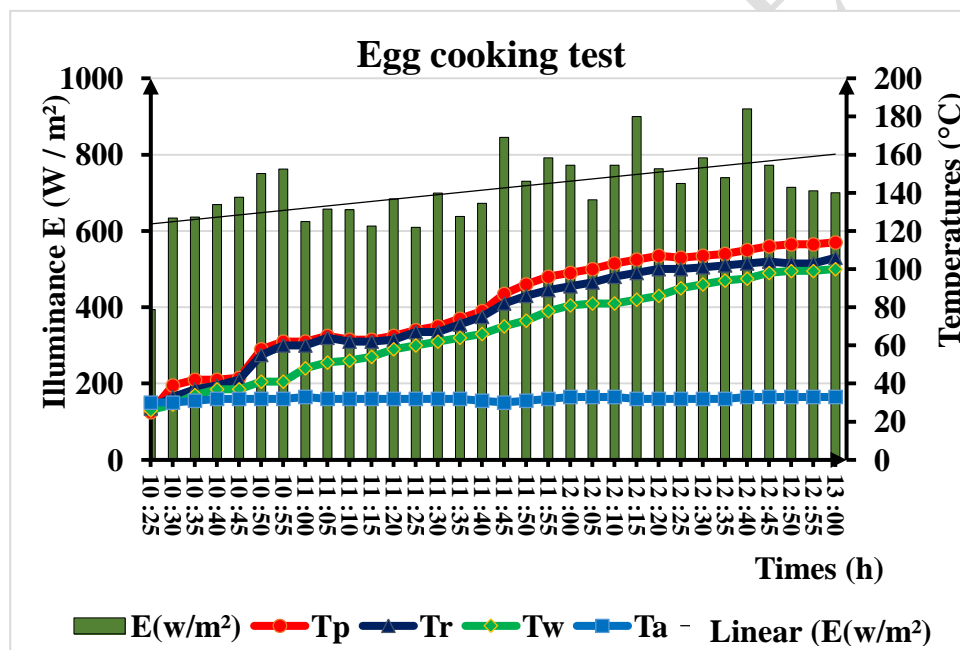

Figure 4: Histogram of illuminance and temperature evolution curves of the absorber, interior air and utensil as a function of time on 12/15/2020.



Figure 5: Photograph of the plates of cooked eggs a) 60 ° C and b) at 86 ° C

5.2. Yam cooking test

On December 18, 2020, a cooking test of the fish stew was carried out. The fish stew cooking test started at 10h 25min and ended at 13h, i.e. after a duration of 2h 35min. During this test, the temperatures of the various compartments of the cooker (absorber, cooking utensil, interior air, interior glass, exterior glass, bottom of the cooker, side face and the ambient temperature) as well as the solar illumination were measured. The average illuminance is estimated to be 636.98 w / m². The evolution of certain temperatures and illuminance as a function of time is shown in Figure 6. The histogram of illuminance shows fluctuations due to the passage of dust clouds. These disturbances are felt in the temperatures of the cooking utensil, the absorber, the interior air. The average value of the ambient temperature was 32 ° C. After 2 hours 35 minutes of cooking, the temperature of the cooking utensil reaches 100 ° C. The fish stew is cooked (Figure 7.b).

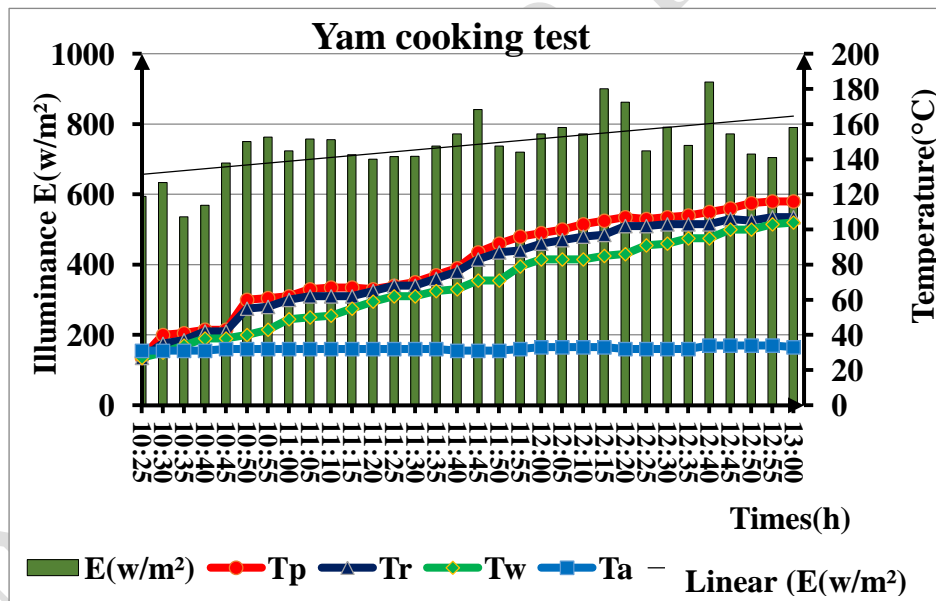

Figure 6: Histogram of illumination and temperature evolution curves of the absorber, the interior air and the cooking utensil as a function of time on 12/18/2020



Figure 7: Photograph of the fish stew a) before cooking and b) after cooking

6. Conclusion

This paper represents the experimental results of an investigation carried out at the Laboratory of Fundamental and Applied Physical Sciences of the Ecole Normale Supérieure (ENS) of Abidjan in the dry season on a box-type solar cooker with an inclined receiving surface equipped with a reflector. This solar cooker was made using available and cheaper materials. Good performance is obtained, as a result of better interception of solar rays. The temperature of the absorbent plate is above 100 ° C, which allows a healthy way of cooking food. The results obtained from the experimental tests are therefore satisfactory and encouraging. This solar application can be of great use to populations, especially in a context of protection of the planet and sustainable development.

REFERENCES

- [1] PNUD: Formuler des scénarios climatiques pour éclairer les statistiques développement résilient au climat, Guide à l'intention des praticiens (2011).
- [2] Majid Ezzati, Alan D Lopez, Anthony Rodgers, Stephen Vander Hoorn, Christopher, J L ,Comparative Quantification of Health Risks, Global and Regional Burden of Disease Attributable to Selected Major Risk Factors (2002) Selected major risk factors and global and regional burden of disease. Lancet, 360: 1347-1360.
- [3] Smith, K.R., Mehta, S. et Maeusezahl-Feuz, M. . Indoor smoke from household solid fuels (2004).
- [4] UNDP. World energy assessment 2000 – energy and the challenge of sustainability. New York: UNDP; (2000).
- [5] M. Hardy, 'Du soleil dans les pays du sud : Entre autonomie et dépendance de développement ?', Institut d'Etudes Politiques de Lyon, France, 2005.
- [6] Panwar NL, Kaushik SC, Kothari S. Role of renewable energy sources in environmental protection: a review. Renew Sust Energy Rev (2011) doi:10.1016/j.rser.2010.11.037.
- 7 Cuce, E., Cuce, P. M., A comprehensive review on solar cookers. Applied Energy (2013) 102, 1399-1421.
- 8 Mahavar, S., Rajawat, P., Punia, R. C., Sengar, N., Dashora, P.,. Evaluating the optimum load range for box-type solar cookers. Renewable Energy (2015)74, 187-194.
- 9 Funk, P. A., Evaluation the international standard procedure for testing solar cookers and reporting performance. Solar Energy(2000) 68 (1), 1-7.
- 10 Khalifa, A. M. A., Taha, M. M. A., Akyurt, M., Solar cookers for outdoors and indoors. Solar Energy(1985) 10 (7), 819-829
- 11 Mullick, S. C., Kandpal, T. C., Saxena, A. K., Thermal test procedure for box-type solar cookers. Solar Energy (1987)39 (4), 353-360.
- 12 Kumar, N., Vishwanath, G., Gupta, A.,. An exergy based test protocol for truncated pyramid type solar box cooker. Energy (2011) 36, 5710-5715.
- 13 Kumar, N., Vishwanath, G., Gupta, A., An exergy based unified tests protocol for solar cookers of different geometries. Renewable Energy (2012)44, 457-462.
- 14 Öztürk, H. H., Experimental determination of energy and exergy efficiency of the solar parabolic-cooker. Solar Energy (2004) 77, 67-71.
- 15 Petela, R., 2005. Exergy analysis of the solar cylindricalparabolic cooker. Solar Energy 79, 221-233.
- [16] D. Soro , Y. Doumbia ,B. Marí ,B.Fofana ,N. A. YAO ,S. Touré B. Aka

- Evaluation of the thermal performance of a box type solar cooker in the rainy season in a sub-Saharan country, International Journal of Engineering & Technology (2020)
- [17] D. Soro, Daouda Soro, M. Sidibé, Y. Doumbia, S. Touré, B. Marí, Theoretical and Experimental Studies of a Box-Type Solar Cooker in Unfavorable Climatic Conditions, Smart Grid and Renewable Energy, (2020)
- [18] John A. Duffie William A. Beckman, Solar engineering of thermal processes, University of Wisconsin Solar Energy Laboratory (2013) DOI:10.1002/9781118671603.
- [19] Guedira, A. Benallou. A «Procédure de qualification des capteurs plan sous ensoleillement naturel au Maroc», Revue des Energies Renouvelables, journées de thermique (2001).
- [20] Solar Cooking,» SCInet, [En ligne]. Available: <http://solarcooking.org/>. (Accessed on 09/20/2021).

UNDER PEER REVIEW