Mechanical structure design and test of multi wire diameter high voltage cable cutting machine

ABSTRACT

Aiming at the problem that the aluminum strand stripping efficiency of high-voltage cable in China's power industry is low and easy to damage the wire core used for cable connection, according to the requirements of aluminum strand stripping of high-voltage cable, a multi wire diameter cable cutting machine is designed in this paper. The key components of the cutting machine are theoretically analyzed, and the effects of the function of the machine and the single extension distance of the push rod on the cutting effect and cutting rate are experimentally studied. The experimental results show that when the driving motor speed is the same, the cutting rate increases with the increase of the extension distance of the push rod; When cutting 22mm and 50mm wire diameter wires, the single extension of the push rod into 10mm aluminum strand stripping effect is the best. When cutting 35mm wire diameter wires, the single extension of the push rod into 5mm has a better effect. The cable cutting equipment can achieve the design goal and better meet the requirements of aluminum strand stripping operation.

Key words: structural design; Aluminum strand; Wire stripping equipment ;Multi wire diameter

1. INTRODUCTION

At present, most of the overhead bare conductors in China's power industry are steel cored aluminum strand or carbon fiber composite core conductors, which are convenient for erection and maintenance and low cost, but they are prone to failure due to the impact of weather and environment. The conductor is wrapped with several layers of aluminum stranded wires. Before crimping, the aluminum strands shall be cut off to expose the steel core or composite core for connection. The cross section of steel wire aluminum stranded wires in China's overhead lines is required to be no less than 35mm, which leads to great difficulty in conductor erection and line maintenance. The quality of cable connection is the key link to ensure the smooth flow of the cable line, but most of the workers only



(a)



(b)



(c)



(d)

**(a) Aluminum strand stripper (b) electric stripper
(c) electric rotary stripper (d) split stripper**

Fig.1 several common wire stripping tools

It can be operated manually. The tools currently used are shown in Figure 1. Figure (a) is an aluminum strand stripper. It requires workers to pull the opening and closing rod, put the conductor into the opening, and use the saw blade to peel the conductor. The workers have heavy workload, low efficiency and are easy to cut the wire core; In order to reduce construction defects, some simple manual tools are gradually used in the industry with reference to foreign methods, such as the electric wire stripper in Figure 1 (b). After the wire is sleeved, the wire is cut with a saw blade, but the cutting effect can only be guaranteed by the working experience of workers, and there is a lack of wire core protection device; Figure 1 (c) shows the commonly used ground wire stripping device, which has large size, high efficiency and can ensure the quality of wire core to a certain extent, but it is not suitable for high-altitude operation; Figure 1 (d) shows the relatively advanced split aluminum strand stripping device at present. According to the different wire diameters, it is equipped with cutter heads with different diameters. When stripping wires with different diameters, it only needs to replace the cutter head. It has small size and high efficiency, which can effectively ensure the cutting quality and precision, but the operation is cumbersome and the cost is high.

In order to solve the key factors that cannot guarantee the cable pretreatment in the power industry, such as the control of the cutting depth and position accuracy of the cable sheath, the stripping depth and position accuracy of the shielding layer, semi conducting layer and insulating layer of the split phase cable, the shape of the cutting section and the surface quality, according to the following two points: ① the cable cutting equipment can ensure that the

cutting depth can be accurately controlled within 10mm, The cutting machine needs to avoid damage to the wire core in the cutting process. ② Improve the cutting speed of cable cutting equipment, control the average cutting time of cable cutting, ensure the safety of operators in the cutting process, and comprehensively consider the advantages and disadvantages of wire stripping tools used in China's power industry, a new cable cutting equipment is designed. The equipment adopts rotary cutting mode, which provides a new idea for the research and development of wire stripping equipment.

2. Overall structure and working principle of machines and tools

The overall structural design of the cutting equipment for high-voltage cables with full diameter is shown in Figure 2. The equipment is mainly composed of seven parts: clamping nut, support cylinder, drive motor, driving gear, driven gear, cutting saw and fastening claw. The supporting cylinder is the bearing part of the cable and cutting assembly, and is the main part of the clamping device for fixing the conductor. Together with the clamping nut and fastening claw, the conductor is fixed on the cutting equipment.

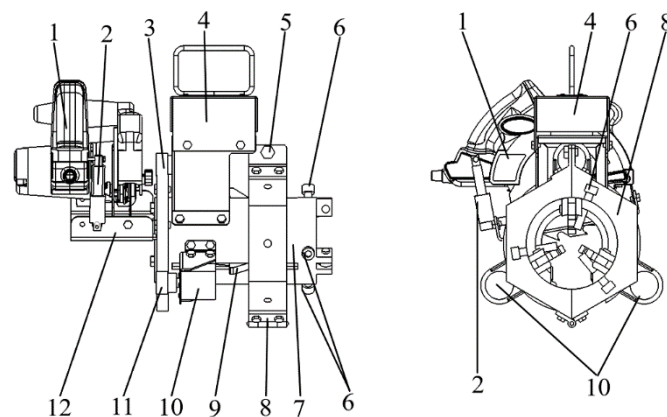

1. Electric saw 2 Electric push rod 3 Driven gear 4 Power box 5 Opening and closing bolt 6 Clamping bolt 7 Support cylinder 8 Clamping nut 9. Fastening claw 10 Drive motor 11 Driving gear 12 floor

Fig. 2 overall structure of equipment

The clamping nut is correspondingly screwed on the outside of the support cylinder through the external thread on the peripheral surface of the support cylinder, and three fastening claws are distributed in the accommodation hole on the peripheral surface of the support cylinder. The outer end of each fastening claw is hinged on the hinge ear at the corresponding position, each hinge ear is fixed on the end face of the outer end of the support cylinder, the abdomen of the free end of each fastening claw is provided with an inward protruding claw head, and the back of the middle section of each fastening claw is provided with an outward protruding driving head. When the fastening nut rotates clockwise, drive the fastening claw to clamp and center the cable. Through the mutual cooperation of the three parts of the support cylinder, the fastening claw and the clamping nut, the cutting work of the conductor with a core diameter of 20 to 50mm can be met. The cutting component is composed of an electric saw cutting machine, a gear, a fixing ring and a driving motor. The electric saw cutting machine is refitted from the common electric circular saw in the market. The driven gear is rotationally connected to the fixed ring at the end of the supporting cylinder, and the electric saw cutting machine is fixed on the driven gear and rotates with it. The driving gear is coaxially

fixed on the driving motor, and the driving motor is fixed on the supporting cylinder with the motor support. The three driving gears are driven by the driving motor and the driven gear meshed with them, so that the electric saw cutting machine can cut around the wire, so as to achieve the purpose of automatic cutting.

The working principle of the equipment is as follows: firstly, screw the driven gear to the opening of the support cylinder to make it a through hole, and then put the conductor into the support cylinder from the through hole; Then screw the clamping nut, drive the fastening claw to shrink inward, clamp the wire and conduct automatic centering on the wire. After that, screw the clamping bolt outside the support cylinder into the bolt hole, according to the laser marked bolt, go deep into the same scale, clamp the conductor twice, ensure the accuracy of centering and ensure the stability during cutting. After fixing the wire with the cutting equipment, determine the cutting depth according to the diameter of the wire. By adjusting the limit bolt on the limit hole, the depth of the sawtooth cutting blade passing through the cutter through hole can be adjusted, so as to adjust the cutting depth of the cutting blade. Before cutting, turn on the switch of the driving motor, make the driven gear rotate through gear transmission, and then drive the electric saw cutting machine to cut the wire in a ring with corresponding depth, so as to realize the non-destructive automatic cutting of the cored wire, which can be used in ground and high-altitude operations, and greatly improve the construction efficiency.

2.1 DESIGN OF CUTTING PART

The calculation model of cutter head and cutting edge slope is established. Under the action of power, the cutter head cuts aluminum strands. When the cutting depth is h , its stress diagram is shown in Figure.3.

Fig 3: cutter head and cutting edge slope

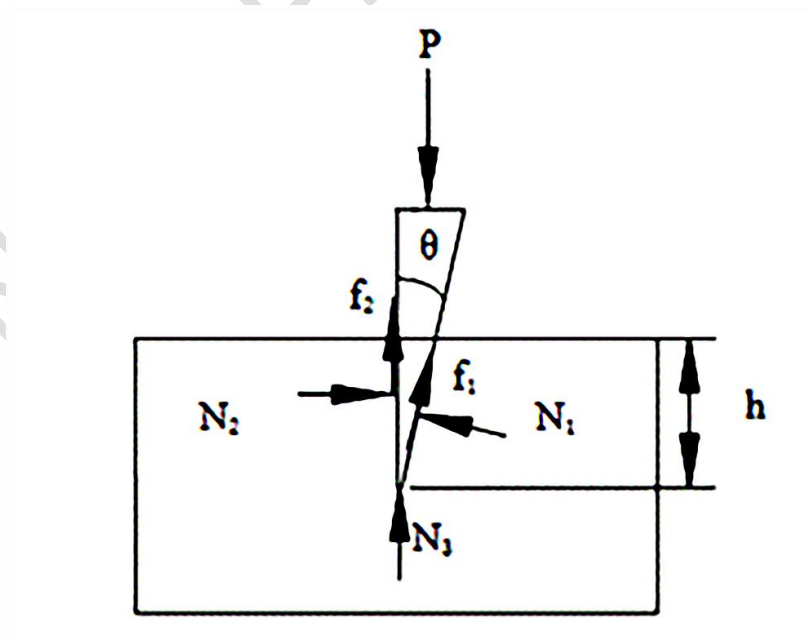

According to the force balance:

$$P = N_1 \sin \theta + f_1 \cos \theta + f_2 + N_3$$

Where

p - thrust of cutting aluminum wire by cutter head, n
 N1 - positive pressure of aluminum wire on wedge angle side blade, n
 N3 - positive pressure of aluminum wire on blade end, n
 Friction force of wedge-shaped aluminum wire, n-PLANE
 F2 - friction force of aluminum wire on the vertical surface, n

θ – Wedge angle on the vertical side of the blade,

$$f_1 = \mu_1 N_1$$

$$f_2 = \mu_2 N_2$$

N2 - positive pressure of aluminum wire on vertical side blade, n
 μ – Friction coefficient between blade and aluminum wire,

Set the width of the blade as δ , The width of the widest part of the cutting aluminum wire is m

$$N_1 = \frac{\sigma_2 h m}{\cos \theta}$$

$$N_2 = \sigma_2 h m$$

$$N_3 = \sigma_1 \delta m$$

Where

σ_1 - average stress between aluminum wire and blade end, MPa
 σ_2 - average stress of aluminum wire and wedge-shaped surface and straight elevation of blade, MPa

You can get

$$f_1 = \mu N_1 = \frac{\sigma_2 h m \mu}{\cos \theta}$$

$$f_2 = \mu N_2 = \sigma_2 h m$$

Substitute F1, F2 into

$$P = \sigma_1 \delta m + \sigma_2 h m (\tan \theta + 2\mu)$$

Average stress at this time σ_1 , σ_2 equals σ Can be simplified to

$$P = \sigma m (\delta + h (\tan \theta + 2\mu))$$

According to the derived formula 3, the wire model takes JL1 / g3a-1250 / 70 as an example to calculate the cutter head thrust, as shown in the table below.

Table 1. Cutting related parameters

Conductor model		JL1/G3A-1250/70
Number of structural elements /Diametermm	aluminium	76×4.58
	steel	7×3.57
Sectional area/mm ²	aluminium	1252.09
	steel	70.07
	total area	1322.16
Diameter/mm		47.35
Calculated weight Kg/Km		4011

Breaking force kN	279.5185
Modulus of elasticity (N/mm ²)	62200

The diameter of single aluminum strand is 4.58mm, the H value is 4.58mm, the m at the widest part of the conductor is 47.35mm, and the average stress of aluminum strand is σ Take 100MPa, friction coefficient of aluminum to steel μ It is generally 0.3, and the blade thickness is 0.5mm. For different wedge angles θ When taking 10 ° to 20 °, the corresponding thrust P can be calculated respectively, as shown in table 2-2 below.

Table 2. Required thrust

	Length/m (mm)	Blade width/ δ (mm)	Friction coefficient/ μ	Wedge angle θ (°)	Height/h (mm)	Average stress/ σ (Mpa)	Calculated shear force/P (N)	Calculated shear force/P (t)
1	47.35	0.5	0.30	10	4.58	100	19203	1.96
2	47.35	0.5	0.30	11	4.58	100	19595	2.00
3	47.35	0.5	0.30	12	4.58	100	19989	2.04
4	47.35	0.5	0.30	13	4.58	100	20386	2.08
5	47.35	0.5	0.30	14	4.58	100	20786	2.12
6	47.35	0.5	0.30	15	4.58	100	21190	2.16
7	47.35	0.5	0.30	16	4.58	100	21598	2.20
8	47.35	0.5	0.30	17	4.58	100	22009	2.25
9	47.35	0.5	0.30	18	4.58	100	22426	2.29
10	47.35	0.5	0.30	19	4.58	100	22846	2.33
11	47.35	0.5	0.30	20	4.58	100	23272	2.37

3. PERFORMANCE TEST

In order to test the performance of the cutting machine test device and select the appropriate extension distance of the push rod for the cutting of wires with different wire diameters, a multi wire diameter high-voltage cable cutting machine test platform is built.



Fig. 4 Test device for multi wire diameter high voltage cable cutting machine

The main evaluation indexes for the pretreatment of the conductor are: the time taken to completely peel off the outer aluminum strand and whether the conductor core is intact. The cutting of steel cored aluminum strand and carbon fiber composite core conductor and the time

of stripping the outer aluminum wire directly affect the final construction efficiency; Cutting the wire core affects the completion of the subsequent wire crimping work and whether the wire can operate normally during the working process. According to the orthogonal test table designed in this paper, the following data statistics are finally completed

At the same speed of the driving motor, when cutting wires with different wire diameters, the cutting speed increases with the increase of the single extension distance of the push rod. It can be seen from Figure 3 that when cutting 22mm conductor, the aluminum strand is not completely stripped when the push rod extends into 5mm and 15mm at a single time; When cutting 35mm conductor, the protective layer of wire core is damaged when the push rod extends 10mm in a single time, and the aluminum strand cannot be completely stripped when it extends 15mm; When cutting 50mm conductor, the aluminum strand is not completely stripped when the push rod extends into 15mm at a single time. The conductor section is shown in the figure

Table 3. Experimental result

	Diameter/mm	speed RPM	Feed rate /mm	Cutting time /s	Number of cutting turns
1	22	66	5	52	8
2	22	66	10	39	6
3	22	66	15	35	5
4	35	66	5	98	13
5	35	66	10	66	9
6	35	66	15	63	8
7	50	66	5	137	20
8	50	66	10	118	16
9	50	66	15	107	12

The conductor section is shown in Figure 4-3. When cutting 22mm conductor, the aluminum strand cannot be completely stripped when the single feed depth is 1mm and 3mm; When cutting 35mm conductor, the protective layer of wire core is slightly damaged when the single feed depth is 2mm, and the aluminum strand is not completely stripped when the feed depth is 3mm; When cutting 50mm conductor, the aluminum strand cannot be completely stripped when the single feed depth is 3mm, and the other effects are good.

Fig 5:

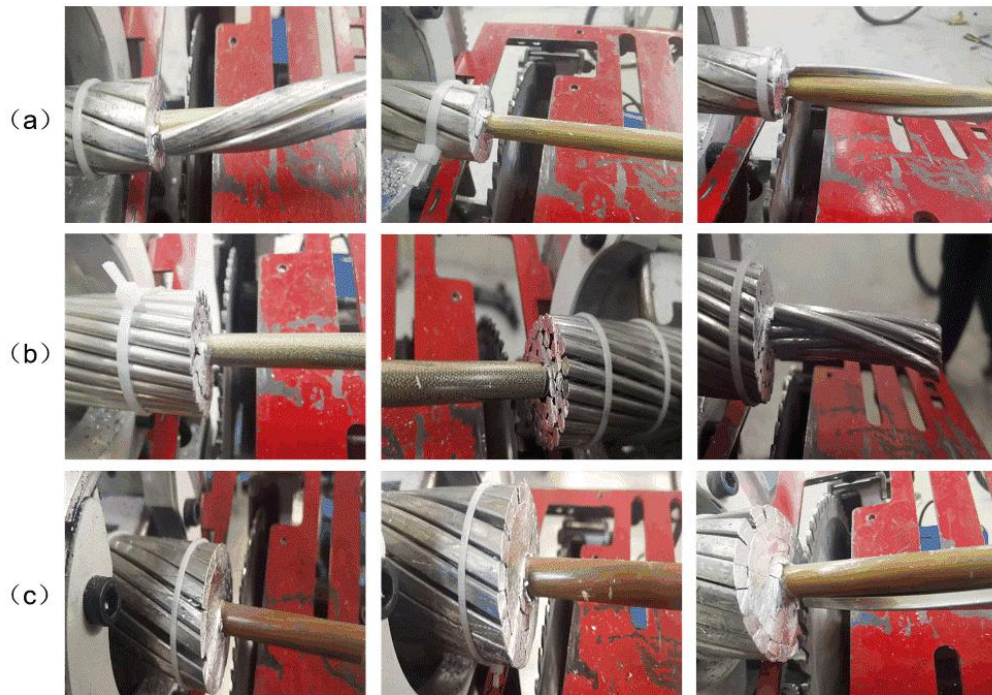

4. CONCLUSION

According to the needs of wire stripping operation, a multi wire diameter high-voltage cable cutting machine is developed. The machine can strip wires of various wire diameters without damaging the wire core. The indoor test of multi wire diameter cutting effect is carried out. The test results show that the cutting efficiency increases with the increase of the feed depth of the push rod, and the wire stripping speed is limited compared with that of 15mm. When the speed of the driving motor is constant, the aluminum strand is stripped completely without damaging the wire core when the wire diameter is 22mm and the wire push rod extends 10mm in a single time; The cutting wire diameter is 35mm, the conductor push rod extends into 5mm aluminum strand at a single time, the stripping is complete and the wire core is intact; When the cutting wire diameter is 50mm and the wire push rod extends into 10mm at a time, the cutting effect is better and the speed is faster. The multi wire diameter high-voltage cable cutting machine can reach the design goal and better meet the requirements of stripping aluminum strands.

Since this test is to test the implementation effect of the core functions of the equipment and does not control the speed of the drive motor, the speed control of the drive motor and the wire centering function will be further improved in the next stage. On the original basis, the motor speed regulating box and automatic centering device are installed to determine the best equipment parameters for different wire diameters.

References

- [1] Li Zhichao, Fu Wei, Sun Jian Discussion on the application of distributed DC power supply in distribution network system [J] Electrical abstracts, 2014 (04): 36-39. Chinese.
- [2] Huang Yanqing Discussion on switchgear configuration of 10kV distribution network [J] Science and wealth, 2018, 000 (013): 3. Chinese.
- [3] Guo Rui. Lightning protection analysis and preventive measures of 500kV transmission line [J] China new communications, 2018,20 (18): 237. Chinese.

[4] Zhu Jianlong Cable construction quality and common fault handling measures [J] Nanfang agricultural machinery, 2018,49 (08): 165. Chinese.

[5] He Bing, Liu Xinping, Hou Xiaoming, et al. Comparative analysis of conductor selection in transmission line capacity expansion projects in large cities [C] // Electrical Engineering in six provinces and one city in East China China Society of electrical engineering, 2009 .Chinese.

UNDER PEER REVIEW