

Thermal Properties of Biogas from Tea leaves Substrate.

Joel Mokuu⁺⁺, Joash Kerongo⁺ and Sebastian Waita^{*}

⁺ Department of Physics, Kisii University, P.O. BOX 408 – 40200 Kisii, Kenya;

^{*} Condensed Matter Group, Department of Physics, University of Nairobi, P.O. BOX 30197-00100, Nairobi, Kenya.

ABSTRACT:

Currently, about 75% of the energy consumed in the world comes from fossils fuels and Kenya is no exception. Fossils fuels are delectable besides creating other environmental issues like global warming through the emission of green gases. Wood as a source of thermal heat energy is used in tea industries in energizing boilers for tea leaves drying. There is need to explore safer energy technologies. This research was exploring the thermal potential of biogas from tea leaves as a clean source of energy, its ability in powering tea industries boiler plant and its potential to reduce greenhouse gas emissions from the tea industries. Kisii county in Kenya is an agriculturally rich area in terms of tea as well as banana production. It has been observed that a considerable amount of tea leaves rejected at the factory and tea buying centers is just wasted away. The production of biogas was investigated in the laboratory using the simple single-state digester. The digester was fed with crashed tea leaves of about 500 grams and operated at room temperature of about (21-26 °C) for 20 days. The amount of biogas generated in terms of volume by a given mass of the tea leaves was also determined and Boswell equation was used to determine the thermal value of biogas produced. Data from the digester was collected daily and recorded in the laboratory spread sheet. The gas was analyzed by a gas Chromatograph machine model 8610C connected to a display computer. Tea substrates were categorized into four samples, sample S₁ was fresh tea leaves from farms, sample S₂ was tea leaves from composite pits of tea factory, for sample S₃ and S₄ was same as S₁ and S₂ respectively with an addition of 10ml of 1 molar sodium hydroxide to create a slightly alkaline environment. 500g of each of the samples of tea substrate were mixed after crushing them using a blander and were mixed with water to a volume of 5000 ml. It was observed that samples with sodium hydroxide (S₃ and S₄) produced more biogas (3800-4000ml) than those without (S₁ and S₂) (1800-2000ml) which was attributed to the basic environment which make the anaerobic digestion faster. The gas production was optimum after about 7-12 days. The thermal value of biogas was about 22MJ m⁻³ and the thermal value of methane was about 36MJ m⁻³, which has an electrical value of 6.1 kWh. From the results the thermal value of biogas from tea leaves can easily operate the boilers if the biogas is produced in large scale, besides reducing cases of deforestation and greenhouse gas emission to the environment.

Key words: Biogas, thermal value, environment, energy, tea leaves, greenhouse gas

BACKGROUND TO THE STUDY

The third largest producer of tea in the world is Kenya and the tea industry provides livelihoods for hundreds of thousands of rural Kenyans. Tea industries in Kenya mostly used electricity from

the national grid system to power the production line, while Biomass is used to provide thermal power to dry the tea. In the production of tea electricity accounts up to 17% of the production cost, making the profits generated from tea industries to be very low due to the cost of electricity power that they are supplied from the main national grid (Musyoka, 2012).

Scientists have issued warnings about human activities threatening to irreversible changes to the Earth's climate. There are no clear pathways to preventing the worst impacts of global warming. As global warming keeps on increasing, pollution has continued to increase, while continued scientific study has revealed that global warming will result in more severe impacts to ecosystems and human civilization. The scientific effort to reduce global warming emissions dramatically and immediately is unyielding due to continuation of use of energy resources that are polluting the environment by emitting greenhouse gases to the atmosphere. The only way out of this calamity is by operating on an economy that operates largely on clean sources of energy and away from old habits and practices that waste fossil fuels (Nordman, 2014).

The scenarios of climate change highlights how the tea industry is going to be affected. Tea to become a hero crop, the industry needs to adapt to the challenges of climate change. Although the tea sector is not a major contributor to climate change, it needs to explore how to reduce its energy footprint across the value chain, particularly in how it is processed and consumed. The tea industry will need to consider how the future supply chain and distribution networks across the world promote efficiency and new technologies. The greatest impact of climate change on the tea sector will be in production (Brouder *et al.*, 2014).

Tea is largely grown in Kisii County, farmers always incur losses due to the rejection of the tea leaves that are of poor quality or have overstayed in buying centers. The objective of this study

was to make good use of the rejected tea leaves by converting them to biogas. The farmers can benefit from this in that instead of rejecting the poor quality tea completely it can be bought from farmers at a fair price and it's utilized by tea manufacturing industries to produce energy that can be used in the industries (Nordman, 2014).

Treatment of wastes and wastewater can be done by anaerobic conversion of organic materials and pollutants in order to protect the environment. Anaerobic conversion process reduces the potential odour, destroys pathogens, displaces fossil fuels and reduces methane emissions to the atmosphere. The solids and liquids residues from anaerobic digestion can be used as a compost manure or fertilizer and their use can have positive environmental benefits (Tower *et al.*, 2006).

Biogas is produced by the breaking down biodegradable waste inside a landfill gas by a chemical reactions and microbes that are produced inside an anaerobic digester. During an anaerobic digestion process the microorganisms transforms biomass waste into biogas and digestate. The biogas is a renewable energy that can be used for production of thermal energy, electricity and many other operations that use a reciprocating internal combustion engine such Caterpillar gas engines. The digestate that remains is an inorganic matter that was not transformed into biogas which can be used as an agricultural fertilizer (Westerman *et al.*, 2007)

According to Obrecht 2011 the use of biogas can generate enough electricity to meet up to 3% of the North America continent's electricity expenditure. This production has a potential to help reduce global climate change by lowering high levels of methane that is produced when manure is stored under anaerobic conditions and when manure has been applied to the land. Nitrous oxide is also produced as a byproduct of the de nitrification process. Nitrous oxide (N₂O) is 320 times more aggressive as a greenhouse gas than carbon dioxide (Obrecht and Denac, 2011).

According to Wieland (2012) biogas is used for electricity production on sewage works, whereby in a gas engine, the waste heat from the engine is conveniently used for heating the digester, space heating, water heating and cooking. Biogas can replace natural gas used in vehicles if compressed, whereby it can fuel an internal combustion engine or fuel cells (Wieland, 2012).

The many benefits of biogas have started to make biogas a popular source of renewable energy and have gained more market in the United States. Methane gas acquired from cow manure is being tested in the United States if it can be able to produce sufficient energy approximately 100 billion kilowatt hours which can possibly be enough to power millions of homes across America. The United states of America is also trying to prove that biogas use can reduce 99 million metric tons of greenhouse gas emissions or about 4% of the greenhouse gases produced by the United States (Cuellar and Webber, 2008).

In 2007, the German government supported renewable energy strategies by empowering the renewable energy supply so as to provide an answer on growing climate challenges. German increased oil prices by the 'Integrated Climate and Energy Programme'. The trend of renewable energy promotion induced a number of challenges facing the management and organization of renewable energy supply that has also several impacts on the biogas production. First challenge noticed was the high area consumed by biogas electric power supply plants and crops for biogas. In 2011 energy crops for biogas production consumed an area of 800,000 ha in Germany. This high demand of agricultural areas generated new competitions with the food industries (Annamari 2006).

Determination of Energy Potential of Biogas Energy from Substrates

The organic strength of liquid effluents in water and waste water industries is measured using the Carbon Oxygen Demand concept (COD) where One mole of methane gas requires 2 moles of oxygen to oxidize it to CO₂ and water, so each gram of methane gas produced corresponds to the removal of 4 grams of COD (Richards, *et al.* 2010).



1kg COD is equivalent to 250g of methane, which is equivalent to $\frac{250}{16}$ moles of gas = 15.62

moles, 1 mole of gas at STP = 22.4 liters, therefore 15.62 x 22.4 = 349.8 liters = 0.35 m³

At standard temperature and pressure each kilogram of COD removed will yield 0.35 m³ of gas

Up to 75% conversion of organic fraction into biogas, It has a methane content of 50-60% this will depend on type substrate. Biogas typically has a thermal value of about 22MJ m⁻³ and the thermal value of methane is 36MJ m⁻³ (Banks, 2009).

The energy equivalents of methane gas in the digester when the thermal value is converted to electricity can be gotten by:

1 Watt = 1 joule second⁻¹, 1Wh = 1 x 3600 joules, 1 kWh = 3600000 J, 1kWh = 3.6MJ,

$$22\text{MJ m}^{-3} = \frac{22}{3.6} \text{ kWh} = 6.1 \text{ kWh}$$

2.6.1. Buswell Equation

According to Banks (2009) Electrical conversion efficiency = 35% Therefore 1m³ biogas = 2.14kWh. The energy comes from the methane in the biogas. The composition and amount of methane produced in the digester can be done practically by gas chromatography and infrared analysis. Theoretical biogas composition can be determined using Buswell Equation. Buswell created an equation in 1952 to estimate the products from the anaerobic breakdown of a generic organic material of chemical composition Cc Hh Oo Nn Ss (Banks, 2009)

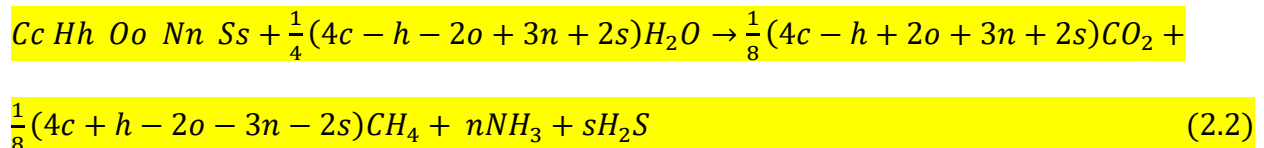

The Buswell equation is used to estimate biogas composition but not volume produced since it assumes 100% material breakdown. Theoretical Method of determine methane in a biogas digester. Carbon content of a feed material can be used in combination with the Buswell equation to estimate methane production.

From the Buswell equation we have 53% of CH₄ and 47% of CO₂ estimates of methane gas and energy yield can be calculated based on the carbon content of the waste. 1000 kg of wet waste the water content is approximately 650kg and Solids content is approximately 350kg dry matter (35%TS) C₄₅₀H₂₀₅₀O₉₅₀N₁₂S₁

$$5400+2050+15200+168+32 = 22850\% \text{ carbon} = \frac{5400}{22850} = 24\% \text{ carbon in 1000kg of wet waste} =$$

350 x 0.24kg C = 84kg C% of carbon biodegraded which is 70%. Then 84 x 0.7 = 58.8 kg C

converted to biogas, from Buswell equation 53% CH₄ and 47% CO₂, weight of methane carbon is given as 58.8 x 0.53 = 31.16 kg C, and weight of methane is given as 31.16 x 16/12 = 41.55 kg of methane. 1 mol gas at STP = 22.4 liters, 16g CH₄ = 22.4 liters, 41550g CH₄ = $\frac{41550}{16}$ moles = 2597 moles CH₄. Therefore 2597 x 22.4 = 58172 liters CH₄ = 58.2 m³ CH₄, 1000 kg wet waste = 58.2 m³ of methane. The Energy value of methane and waste will be 1m³ methane = 36 MJ. 1 Wh = 3.6 MJ. 1m³ CH₄ = 10kWh. This values can be obtained from 1tonne wet waste.

$$58.1m^3CH_4 \times 10kWh m^3CH_4 = 582 kWh \quad (2.3)$$

2.6.2 Composition of Biogas

Table 2.1: Typical Composition of Biogas (Wieland 2012).

Compound	Formula	%
Methane	CH ₄	50–75
Carbon dioxide	CO ₂	25–50
Nitrogen	N ₂	0–10
Hydrogen	H ₂	0–1
Hydrogen sulfide	H ₂ S	0–3
Oxygen	O ₂	0–0.5

Biogas composition varies depending upon the origin of the anaerobic digestion process. Landfill gas typically has methane concentrations around 50%. Advanced waste treatment technologies can produce biogas with 55%–75% methane, for reactors with free liquids can be increased to 80% to 90% methane using gas purification techniques. (Richards *et al.* 2010). Biogas contains water vapor, the fractional volume of water vapor is a function of biogas temperature, and correction of measured gas volume for water vapor content and thermal expansion is easily done

via simple mathematics, which yields the standardized volume of dry biogas. Biogas contains siloxanes in some cases where they are formed from the anaerobic decomposition of materials commonly found in soaps and detergents. During combustion of biogas containing siloxanes, silicon is released and can combine with free oxygen or other elements in the combustion gas. Deposits are formed containing mostly silica (SiO_2) or silicates (Si_xO_y) and can contain calcium, sulfur, zinc, phosphorus. Such white mineral deposits accumulate to a surface thickness of several millimeters and must be removed by chemical or mechanical means (Wieland 2012).

MATERIALS AND METHODS

Area of Study

The study was carried out in three Kisii county tea factories, they include Ogembo tea factory, Eberege tea factory and Nyamache tea factory, . The site was preferable because it covers a wide region of Kisii county and the factories are trying to use modern methods in tea manufacturing and are ready to adopt modern technology to increase their production efficiency

Experimental Design and set-up

This Study adopted an experimental design. Laboratory experimentation is an essential component of anaerobic digestion research in that it allows for multiple experiments to be done simultaneously, granting the ability to change numerous variables and to collect large amounts of data in relatively short periods of time. Quantitative methods were incorporated in the analysis of data. The amount of tea waste substrates in kilograms rejected by tea industries daily were analyzed quantitatively. The amount of methane and other gases produced by tea substrate was also be analyzed.

Data was collected by physically visiting the tea buying centers and the three chosen tea factories around Kisii County. It was found out that between 1st April 2017 to 30th April 2017 Ogembo tea factory collected 1,249,043.70 kilograms of tea of which about 89% of the collection was utilized in the processing of quality tea. The remaining was through in the factory composite pit. The rejected sample from the tea waste and the accepted sample of tea leaves were taken to a laboratory for analysis of its potential in methane gas production.

The samples that are wasted were taken to the laboratory for analysis of how much biogas they produce in terms of the amount of methane gas collected in the laboratory. Samples of tea leaves about two kilograms were blended so as to fasten the anaerobic digestion. The crushed tea was put in a simple glass reactor of 10 litres and some warm water added to the tea leaves to raise the temperature of the mixture for faster rate of reaction. The laboratory set up is as shown below. The collected gas was measured in terms of amount of gas in volume collected after a given duration of time like five to seven hours and the gas volume and its content were analyzed by a gas chromatography.

The Schematic of bench-scale system for biogas analysis in the laboratory that was used in the laboratory to test if tea substrate waste can produce methane is as shown below.

Fig. 3.1 Schematic of bench-scale system for biogas analysis in the laboratory.

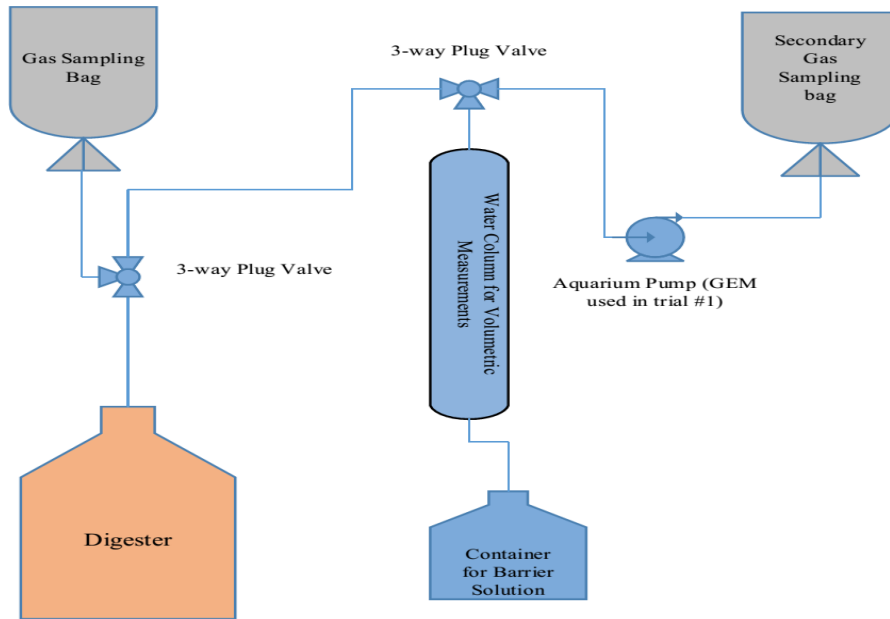

Fig. 3.1 Schematic of bench-scale system for biogas analysis in the laboratory. (Gamble 2014)

Experiments for the methane potential estimation of the samples were collected using 500cm³ gas bag. Four samples of tea leaves were prepared for biogas production.

- i. Sample S₁ were fresh tea leaves from the farm. 2kg of the substrate was mixed with water to a volume of 5000 ml (100% v/v)
- ii. Samples S₂ were poor quality tea from factory composite pit. 2kg of the substrate was mixed with water to a volume of 5000 ml (100% v/v)
- iii. Samples S₃ were prepared as sample S₁ with an addition of 10ml of 1 molar sodium hydroxide to create a basic environment
- iv. Samples S₄ were prepared as sample S₂ with an addition of 10ml of 1 molar sodium hydroxide to create a basic environment

We prepared four bio digesters each containing samples S₁, S₂, S₃ and S₄. Since methane gas is slightly soluble in water and its density is about 0.424g/m³. The gas from the digesters was collected in the laboratory by the method of down ward displacement method and the gas was

collected to the gas bags when the tap for the gas bag is opened. A gas chromatography machine was used to analyze the content of biogas collected.

RESULTS AND DISCUSSION

Thermal Properties of Biogas Energy from Tea Substrate

Biogas collected from the laboratory gas collection bags were as in table 4.1. using Buswell equation where we have 53% of CH₄ and 47% of CO₂ estimates of methane gas and energy yield can be calculated based on the carbon content of the waste. The research used 2kg of wet tea leaves waste, where the water content is approximately 1.3 kg and Solids content is approximately 0.7 kg dry matter which is approximately (35%TS). Elevating the contents to accommodate upto a ratio of 1000 kg where by the experimental 2kg representing 1000kg and taking into account all the ratios and percentages the thermal value of the tea substrate can be calculated as follows from the chemical components of biogas produced from tea substrate.



$5400+2050+15200+168+32 = 2285$. The percentage of carbon = $\frac{5400}{22850} = 24\%$ carbon in 1000kg of wet waste = $350 \times 0.24\text{kg C} = 84\text{kg C}$ of carbon biodegraded which is 70%. Then $84 \times 0.7 = 58.8 \text{ kg C}$ converted to biogas,

From Buswell equation 53% CH₄ and 47% CO₂, weight of methane carbon is given as

$58.8 \times 0.53 = 31.16 \text{ kg C}$, and weight of methane is given as $31.16 \times 16/12 = 41.55 \text{ kg}$ of methane. 1 mol gas at STP = 22.4 liters, $16\text{g CH}_4 = 22.4 \text{ liters}$, 41550g CH_4 .

Table 4.1 shows the daily Volume of biogas collected for the various samples of tea substrates for 20 days

Time (Days)	Volume of biogas collected by Sample S ₁	Volume of biogas collected by Sample S ₂	Volume of biogas collected by Sample S ₃	Volume of biogas collected by Sample S ₄
1	0	0	0	0
2	0	0	0	0
3	0	10	40	100
4	0	30	70	180
5	50	70	200	450
6	260	350	330	550
7	380	680	600	1890
8	550	1200	1100	3780
9	600	1700	2650	3440
10	800	1400	3660	2550
11	1890	1300	4090	1730
12	1500	1100	3470	1560
13	1100	750	2400	900
14	680	460	1090	770
15	490	310	700	380
16	300	200	400	300
17	120	75	250	190
18	60	30	100	80
19	20	15	70	50
20	15	06	30	20

in terms moles it will be $=\frac{41550}{16}$ moles = 2597 moles CH₄. Therefore 2597 x 22.4 = 58172 liters

CH₄ = 58.2 m³ CH₄, 1000 kg wet tea leaves = 58.2 m³ of methane.

The Energy value of methane and waste will be 1m³ methane = 36 MJ.

1 Wh = 3.6 MJ. 1m³ CH₄ = 10kWh. This values can be obtained from 1tonne wet waste.

From the data collected it indicates that biogas production is best when 10ml of 1 molar sodium hydroxide is added to the substrates to create a basic environment which make the anaerobic digestion faster.

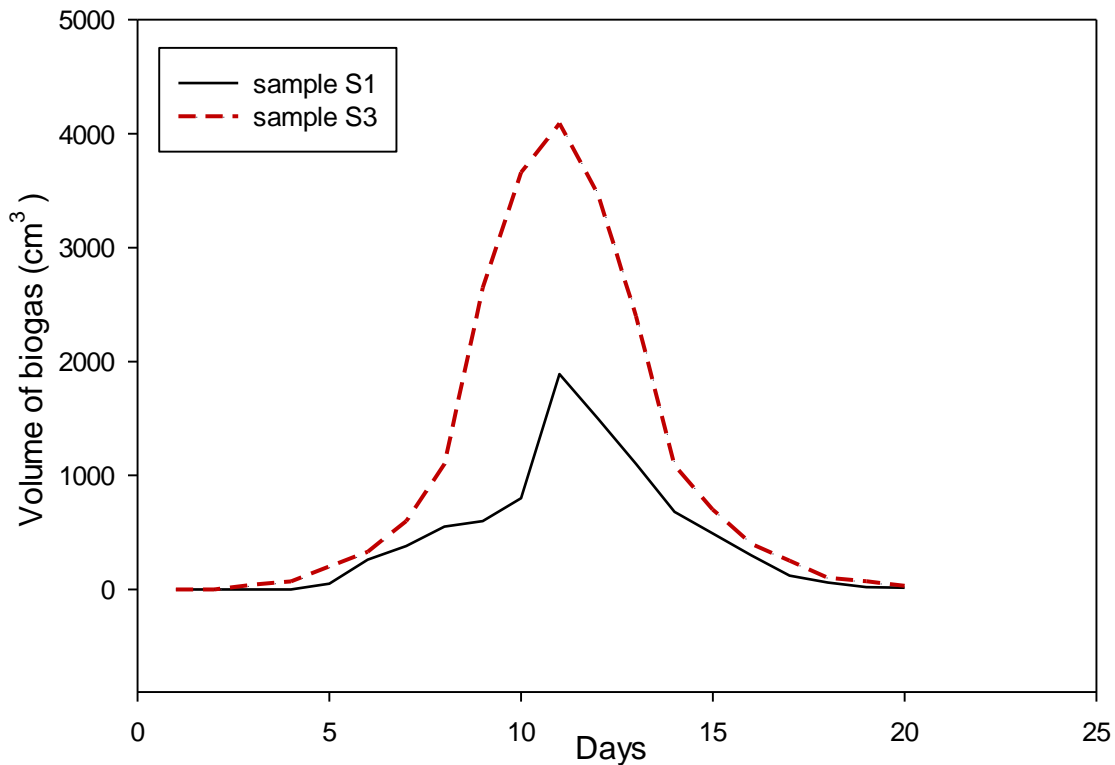
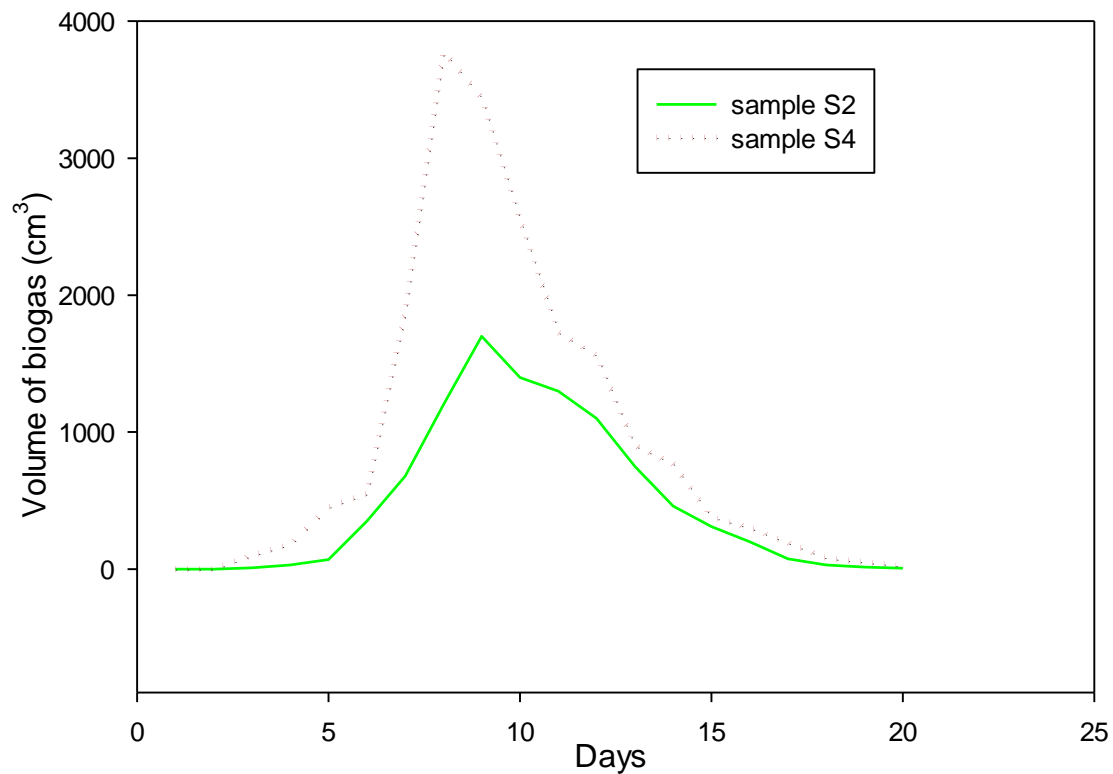

Fig.4.1. A graph of the daily Volume of biogas (cm^3) collected for sample S_1 and S_3 of the tea substrates for 20 days.

From the graph B represents Sample S_1 which was fresh tea leaves from the farm and C represents Samples S_3 which was fresh tea leaves with an addition of 10ml of 1 molar sodium hydroxide. The graph shows that sample S_3 produced biogas at a higher rate than the sample S_1 this is due to the fact that addition of 10ml of 1 molar sodium hydroxide to the substrates created a basic environment which make the anaerobic digestion faster.



The figure 4.2 showing a graph of the daily Volume of biogas collected for sample S₂ and S₄ of the tea substrates for 20 days.

From the graph Sample S₂ was tea from composite pit of tea industries and Samples S₄ was tea from composite pit of tea industries with an addition of 10ml of 1 molar sodium hydroxide. The graph shows that sample S₄ produced biogas at a higher rate than the sample S₂ this is due to the fact that addition of 10ml of 1 molar sodium hydroxide to the substrates created basic environments which make the anaerobic digestion faster.

From figure 4.1 and figure 4.2 drawn above it shows that tea substrate waste collected from tea industries composite pits and added 10ml of 1 molar sodium hydroxide produces biogas faster as from day three, this is because it had started to decompose in the pit and addition 10ml of 1 molar sodium hydroxide provided an alkaline condition for anaerobic digestion to take place. The production of biogas became maximum at day 8 and it started slowly to decrease in its

productivity and by the 17th day almost no biogas was produce since the substrate had undergone complete cycle and the slurry that ended up as a byproduct tested positive for the presence ammonium sulphate $(\text{NH}_4)_2\text{SO}_4$ and ammonium nitrate NH_4NO_3 which are nutritious for the growth of agricultural plants.

Table 4.2 shows the daily variation of volume of the gas collect for 20 days

Time (days)	daily changes in normal volume (cm^3) of the gas collected			
	Sample S ₁	Sample S ₂	Sample S ₃	Sample S ₄
1	0	0	0	0
2	0	0	0	0
3	0	10	40	100
4	0	20	30	80
5	50	40	130	270
6	210	280	130	100
7	120	330	270	1340
8	170	520	500	1890
9	50	500	1550	340
10	200	300	1010	890
11	1090	100	430	820
12	350	200	600	170
13	400	350	1070	660
14	420	290	1310	130
15	190	150	390	390
16	190	110	300	80
17	180	125	150	110
18	60	45	150	110
19	40	15	30	30
20	05	09	40	30

A sample of biogas was realized on the 3rd day. From the results it shows that the performance improved as days elapsed and was at its the peak on the 8th day, where a volume 3780 was collected as shown on table 2. The gas production then started to drop slowly until the 17th day where gas production was almost constant.

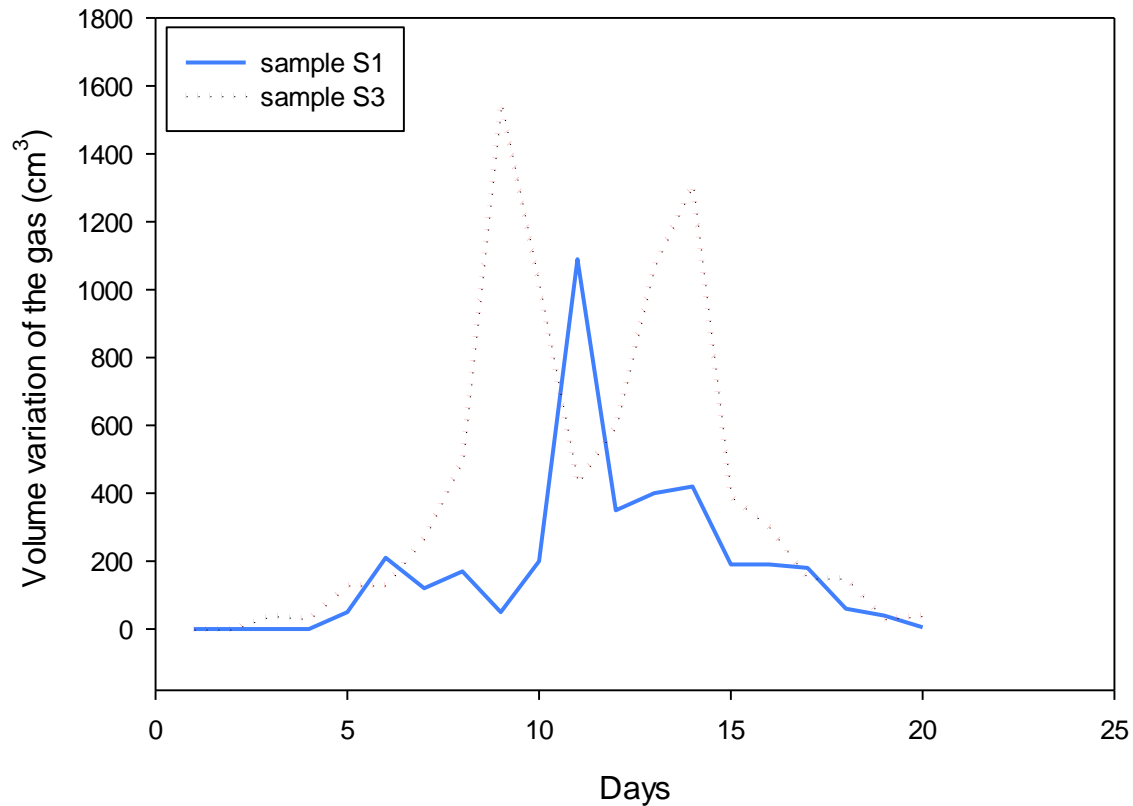

Figure 4.3 showing a graph of the daily variation of volume of biogas for sample S₁ and S₃ gas collect for 20 days

From the graph Sample S₁ was fresh tea from farms and Sample S₄ was fresh tea leaves an addition of 10ml of 1 molar sodium hydroxide.

The variation of the biogas collected was maximum on the 8th day and it started to reduce significantly and on day 17th there was almost no variation almost negligible. As from day 12th the substrates are recommended that they be added fresh one to maintain the process of anaerobic digestion so that biogas does not reduce to minimum before its production is boosted.

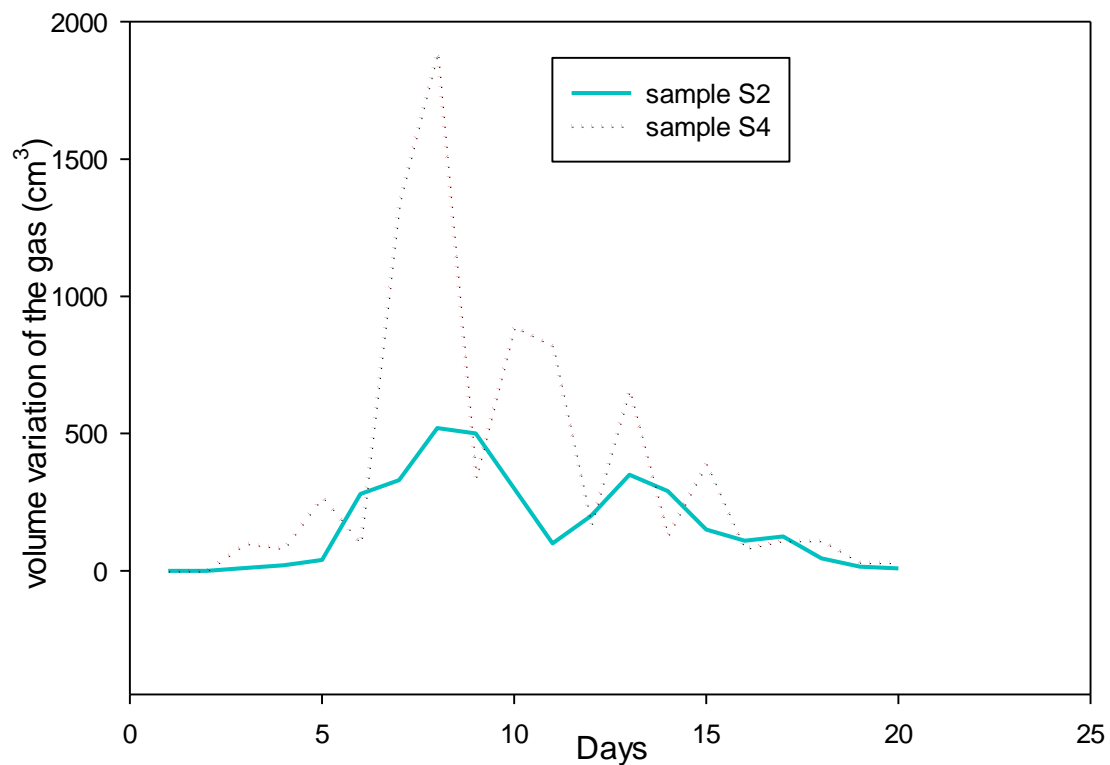

Figure 4.4 shows a graph of daily variation of volume of a gas collected for sample S₂ and sample S₄ for 20 days

From the graph Sample S₂ was tea leaves from composite pit of tea industries and Sample S₄ was tea leaves from composite pit of tea industries with an addition of 10ml of 1 molar sodium hydroxide

Table 4.3 shows the daily cumulative of the gas for 20 days

Time (days)	Sample S ₁	Sample S ₂	Sample S ₃	Sample S ₄
1	0	0	0	0
2	0	0	0	0
3	0	10	40	100

4	0	40	110	280
5	50	110	310	730
6	310	460	640	1280
7	690	1140	1240	3170
8	1240	2340	2340	6950
9	1840	4040	4990	10390
10	2640	5440	8650	12940
11	4530	6740	12740	14670
12	6030	7840	16210	16230
13	7130	8590	18610	17130
14	7810	9050	19700	17900
15	8300	9360	20400	18280
16	8600	9560	20800	18580
17	8720	9635	21050	18770
18	8780	9665	21150	18850
19	8800	9680	21220	18900
20	8815	9686	21250	18920

From table 4.3 shows the cumulative values of biogas collected in 20 days. From the results it shows that sample 4 (S₄) had the highest production of biogas due to its alkaline condition which favors the production of biogas. Addition of 10ml of 1 molar of sodium hydroxide demonstrates the percentage of improvement or inhibition in biogas and methane production for the pretreated samples relative to the non-pretreated control. this significant improvement in cumulative biogas production indicates that organic materials are more readily available for consumption and larger quantities of organic material are available for consumption by the microorganisms in alkaline conditions.

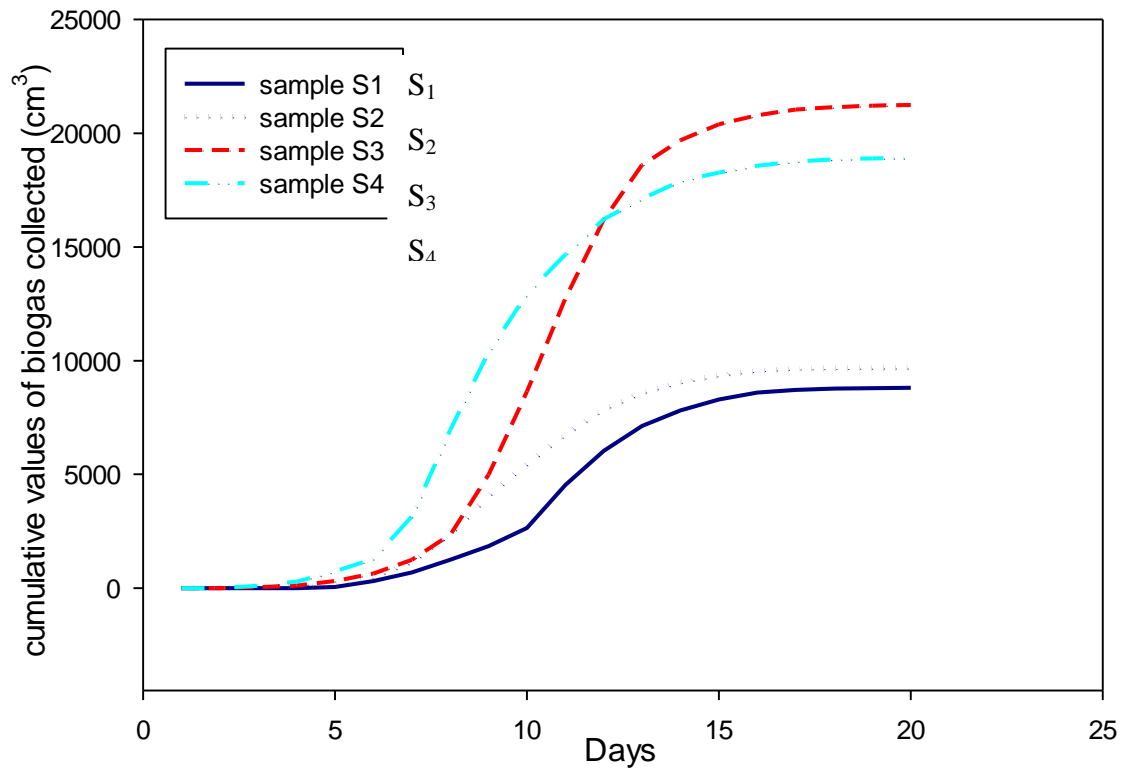

Figure 4.5 shows the cumulative values of biogas collected in 20 days

From figure 4.3 it shows the cumulative curves for biogas production for the four tea substrate wastes characterized by the same quantity of mass. Methane production from tea substrate added with 10ml sodium hydroxide of 1 molar is higher and this indicates that anaerobic digestion was faster in alkaline conditions.

SUMMARY AND CONCLUSIONS

Biogas is a mixture of different gases produced by the breakdown of organic matter in the absence of oxygen. Biogas can be produced from raw materials such as agricultural waste, manure, municipal waste, plant material, sewage, green waste or food waste. (Neal 2012).

This study looked onto the thermal properties of biogas and its possibilities of utilizing the tea leaves to operate steam boilers in tea industries as well as homes with biogas energy. Samples of tea substrate were collected from the tea industries and tea buying centers and composite pit of the industries for biogas analysis in the laboratory. It's was identified that tea substrate has a high potential of biogas generation where at average about 2kg of tea substrate produced about 0.35m^3 of biogas which has a thermal value equivalent to about 6.0kWh. If a biogas plant is constructed in tea industries larger amounts of tea substrate used the biogas produced can easily run the boilers of the industries, (Wieland 2012).

Biogas can be converted into heat, mechanical energy, and electromagnetic energy (light). It can be further more be used as a chemical compound. There exist many different options for the use of biogas raging from very small applications to technically sophisticated installations like lighting in gas lamps, heating in biogas burners, boilers, and gas stoves Rutz (2015).

The following figures are useful for the energy calculation and measurement of biogas plants:

- Energy content of 1 kg biomethane is equivalent to 50 MJ
- Energy content of 1 Nm^3 biomethane is equivalent to 35.5 MJ or about 9.97 kWh
- Biomethane content of 1 Nm^3 biogas is equivalent to 0.45-0.75 Nm^3
- Energy content of 1 Nm^3 biogas is equivalent to 5-7.5 kWh
- Electrical output of 1 Nm^3 biogas is equivalent to 1.5-3 kWh

- Density of 1 Nm³ biomethane is equivalent to 0.72 kg/Nm³, (Hiegl et al. 2011).

CONCLUSION

When tea substrate waste is anaerobically digested the laboratory biogas was realized on the 3rd day. Biogas production increased and was at the peak on the 8th day. The amount of biogas collected by the end of the experiment for the four samples was approximately 78428 cm³ of biogas by the 20th day. This is evidence that tea substrate has a high biogas potential and its thermal energy potential is approximately 10kWh which is sufficient to power up homes and is able to run boilers of tea industries if large digesters are used in the production of biogas. The addition of 10ml of 1 molar sodium hydroxide indicated that alkaline pretreatment on solubilization and anaerobic digestion of organic fraction of tea substrate waste in this research indicated that alkaline pretreatment using NaOH shows the ability to enhance carbon oxygen demand on solubilization of organic waste.

The single-phase, complete-mix used in this research shows that biogas production is feasible for tea substrate wastes disposal instead of it being disposed at composite pits. Considering the characteristics of the high-moisture solid waste in tea leaves anaerobic digestion represents a feasible and effective method to convert the tea waste to biogas fuel. The reactor showed stable performance with highest methane of about 61% with Successful implementation of anaerobic digestion as the method of tea substrate waste treatment leads to the regional utilization of renewable energy resources, reducing energy requirements, reducing the losses incurred by farmers when the tea industries reject their tea leaves as poor quality, provide an energy alternative to the industries and provide farmers with an alternative fertilizer they will be able to use to improve their farm yield.

REFERENCES.

- Banks Charles (2009) Evaluating the Potential for Anaerobic Digestion to provide. University of Southampton, Energy and Soil amendment. University of Reading. 25th March 2009
- Brouder Ann-Marie, Simon Billing and Sally Uren, 2014, steps towards a sustainable future for the tea industry, Forum for the Future on behalf of the Tea 2030 steering group.
- D. Tarvin, A.M. Buswell (2010). The methane fermentation of organic acids and carbohydrates
- Gamble Kevin James,(2014) anaerobic digestion from the laboratory to the field: an experimental study into the scalability of anaerobic digestion, Department of Technology and Environmental Design, Appalachian State University.
- Helge (2012) Environmental Plant project plan, waste becomes energy - important for the environment- a push for the woman - help benefits for the families. Kitui -Kenya: Kalimani Secondary school.
- Mansour (2010). Design and building of biogas digester for organic materials gained from solid waste. Thesis. Nablus - Palestine: An - Najah National University.
- Moomaw, W., F. Yamba, M. Kamimoto, L. Maurice, J. Nyboer, K. Urama, T. Weir, 2011, Introduction. In IPCC Special Report on Renewable Energy Sources and Climate Change Mitigation, Cambridge University Press, Cambridge, United Kingdom and New York.
- Musyoka David201, Tea farmers increase earnings from generating own power, African News Kenya focus.
- Neal Sam, 2012, how can an anaerobic digester benefit a community both environmentally and economically? University of Nebraska-Lincoln

Nordman Erik 2014, Energy Transitions in Kenya's Tea Sector: A Wind Energy Assessment
Funded Articles Paper 18, Grand Valley State University,

Rania Mona Alqaralleh 2012. Effect of Alkaline Pretreatment on Anaerobic Digestion of Organic
Fraction of Municipal Solid Waste, Ottawa-Carleton Institute for Environmental
Engineering, Department of Civil Engineering, University of Ottawa

Richards, B.; Cummings, R.; White, T.; Jewell, W. (2010). "Methods for kinetic analysis of methane
fermentation in high solids biomass digesters". Biomass and Bioenergy .

Tower, P.; Wetzel, J.; Lombard, X. (March 2006). "New Landfill Gas Treatment Technology
Dramatically Lowers Energy Production Costs". Applied Filter Technology.

Wieland, P. 2012 Biomass Digestion in Agriculture: A Successful Pathway for the Energy
Production and Waste Treatment in Germany.