

Design and Implementation of Hybrid Harmonic Filter for Converter System

ABSTRACT

Quality of power is essential for all electrical system towards its reliable operation. In specific voltage/current magnitude, frequency and waveforms are the key parameters which decides the quality of electric power supply. Recently enormous nonlinear loads such as converters, inverters, variable frequency drives, and uninterrupted power supply are used in all modern industrial sectors which leads power quality disturbance in power system. In particular, harmonic distortion is one of the main power quality causes produced by nonlinear loads which will affect the reliable operation of industrial electrical equipments. Harmonic filters help to maintain the harmonic limits as per the IEEE 519-2014 standard. This research article overviews the various types of harmonic filters and the design procedure for passive harmonic filter. Also, this research paper briefly converses the design and control technique procedure for the proposed hybrid harmonic filter, used to control the harmonic distortion produced by three phase converter system. The results of the experimental set up with the implementation of hybrid harmonic filter clearly shows that the harmonic distortion is greatly reduced. The high accuracy power quality analyzer used in this research work measures the real time voltage/current waveforms, power / energy and harmonic profiles.

Keywords: Nonlinear loads, Harmonics, Hybrid filter, Converter, Pulse width modulation,

1. INTRODUCTION

A great number of nonlinear loads like adjustable speed drives and static power switches including those of large capacity ground the power quality strife. The power quality is defined as anything that affects the voltage, current and frequency of the power being supplied to end user. The deviation of the voltage and current waveforms from sinusoidal is described in terms of the waveform distortion, often expressed as harmonic distortion [1]. The power quality problems have increased in the deregulated power systems and that can be mitigated by various filtering techniques [2]. The shunt active filters eliminate the harmonics in the line current by injecting current harmonics in phase with the load current harmonics [3]. The combined system of a passive filter and a small rated active filter both connected in series with each other can be used to mitigate the harmonics in which the passive filter removes load produced harmonics as a conventional one does, the active filter improves the characteristics of passive filter [4].

The active filters are classified based on its power rating, Power circuit configurations, system parameters to be compensated, control techniques employed, techniques used for estimating the reference current/ voltage [5]. Another new approach to compensate for harmonics in power system is hybrid filter which is a combination of shunt passive filter and series active filter. The gate signal to active filter is generated with the help of Instantaneous Reactive Power theory [6]. The Instantaneous Reactive Power theory defines the conventional reactive power in single phase or three phase circuits on the basis of the average value concept for sinusoidal voltage and current waveforms in steady states. This control strategy compensates the fundamental reactive power in transient states and the

harmonic currents [8]. A simple and low cost control strategy for hybrid filter as an alternative to other most complex algorithms is also available that is recommended for utility interface with three phase diode bridge rectifier front – end due to its high displacement power factor [9].

The hybrid active filter combines the compensation characteristics of resonant passive and active power filters which allows a better performance of high power voltage non linear loads by compensating the displacement power factor and current harmonics simultaneously [10]. An adaptive dc-link voltage controlled LC-HAPF (Hybrid Active Power Filter) with a neutral inductor can be applied for both dynamic reactive power and current harmonic compensation in three phase four wire power system, with least switching loss and switching noise[13].

2. OVERVIEW OF HARMONIC FILTERS IN POWER SYSTEM:

2.1 Passive Harmonic Filter:

Harmonics in power system can be mitigated by adopting various filtering techniques. The basic types of harmonic filter configurations are series filters, shunt filters, Passive filters and Active filters. These types of filter provides a high-impedance path for harmonic currents and block them from reaching the power supply but allows the fundamental 50 Hz current to pass through. This type of configuration has the drawback of having to carry the full load current. The other type of filter configuration is a shunt filter that consists of a capacitor and inductor connected in series with each other but in parallel or shunt with the load as shown in Figure 1. This type of filter configuration provides a low-impedance path for harmonic currents and diverts them harmlessly to ground. The shunt filter is most common and less expensive, because it doesn't have to carry the full load current.

2.2 Theoretical Background:

Passive filters are in combination of inductance, capacitance and resistance elements configured and tuned to reduce the impact of harmonics in the power systems. They are employed either to shunt the harmonic currents off the line or to block their flow between parts of the system. The two basic types of passive filters are single tuned and double tuned filters. Single tuned filters are series tuned to present low impedance to particular harmonic currents and is connected in shunt with the system as shown in Fig.1. The double tuned filter performs the same function as two single tuned filters and the losses are much lower in this configuration.

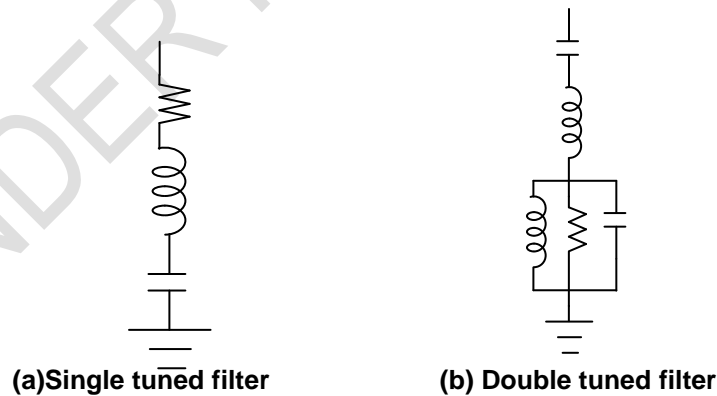

Fig. 1 Passive Harmonic Filters

2.3 Active Harmonic Filter:

Active filters are based on sophisticated power electronics and are much more expensive than the passive filters. However they have the distinct advantage that they do not resonate with the system. Active filters can work independently on the system impedance characteristics. Thus, they can be used in very difficult circumstances where the passive filters cannot operate successfully because of parallel resonance problems. They can also address one harmonic at a time and combat other power quality problems such as flicker. They are particularly used for large, distorting loads fed from relatively weak points on the power systems. The basic idea is to replace the portion of the sine wave that is missing in the current in a nonlinear load.

2.4 Hybrid Harmonic Filter:

Hybrid harmonic filter is an association of active and passive filters, where the active filter inserted in the system acting as impedance, changing its harmonic behavior. The aim is to combine passive filter robustness with active filter performance, improving system reliability. In this method, harmonic reduction and reactive power compensation is shared between a passive filter and modest active filter. Various topologies of hybrid harmonic filters are

- (i) Combination of series active filter and shunt passive filter
- (ii) Combination of shunt active filter and shunt passive filter
- (iii) Active filter connected in series with shunt passive filter

The third topology is implemented in the proposed work and shown in Figure 3. A three phase width modulation (PWM) voltage source inverter operating at fixed switching frequency is acting as active filter. This active filter connected series with the passive filter is used for the purpose of improving the characteristics of passive filter.

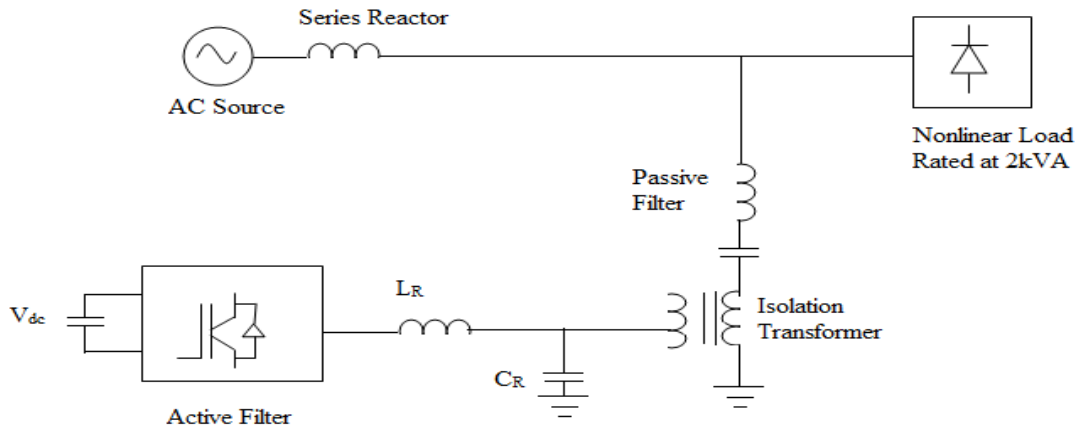

Fig 2. Hybrid Harmonic Filter

2.5 Design of Passive Harmonic Filter Parameters:

Design of Passive Harmonic Filter:

Single tuned filters are designed by taking the values of voltage, power factor and apparent power of the bus without the filter. Conventional method for design of passive harmonic filter is depicted here [18] and [19].

Reactive power of the filter is

$$\text{KVAR} = \text{KVAR}_1 - \text{KVAR}_2 \quad (1)$$

$$\text{KVAR}_1 = \text{KVA} \sin(\cos^{-1}(\text{pf}_1)) \quad (2)$$

$$\text{KVAR}_2 = \text{KVA} \sin(\cos^{-1}(\text{pf}_2)) \quad (3)$$

pf_1 = Power factor of load without filter placement

pf_2 = 0.98 (Desired Powerfactor)

$$\text{Filter reactance } X_{\text{filter}} = (KV^2 * 1000)/KVAR \quad (4)$$

$$\text{Capacitive reactance } X_{\text{cap}} = (X_{\text{filter}} * h^2)/(h^2 - 1) \quad (5)$$

$$\text{Inductive reactance } X_{Lh} = X_{\text{cap}} / h^2 \quad (6)$$

$$\text{Filter Inductance } L_h = X_{Lh} / (2\pi f) \quad (7)$$

$$\text{Filter Capacitance } C_h = 1 / (hf * 2\pi * (L_h)^{1/2})^2 \quad (8)$$

$$\text{Filter Resistance } R_h = (h * X_{Lh}) / Q \quad (9)$$

Where, h – Order of harmonics

KVA– Load apparent power ;

KVAR – Load reactive power ;

KV– Load voltage

2.6 Control Techniques for Active Harmonic Filter:

The Active filters can be controlled by using any of the following approaches. The various control techniques are listed here.

- (i) Instantaneous Reactive Power theory
- (ii) Synchronous flux detection method
- (iii) Synchronous frame method
- (iv) Constant Active Power Algorithm

3. ARM PROCESSOR BASED PROPOSED HYBRID ACTIVE POWER FILTER:

The proposed system incorporates the series connection of active and passive harmonic filter that forms the hybrid harmonic filter. The hybrid harmonic filter is connected in shunt with the three phase diode bridge rectifier acting as a nonlinear load rated at 2.2kW. The passive filter is tuned to fifth, seventh and eleventh order frequencies. The three phase PWM voltage source inverter is acting as an Active Filter. The three phase voltage and current are sensed with the help of potential and current transformers and given as input to the control circuit. The three phase voltage and current are converted into the instantaneous real and reactive power (p,q) by using the clarke transformation [6]. The algorithm is written in ARM Processor and the processor will generate the gate signal to this active filter. In addition to harmonic current compensation, the shunt active filter brings an increase in current rating to the active filter. The schematic diagram of the proposed work is shown in Figure 3.

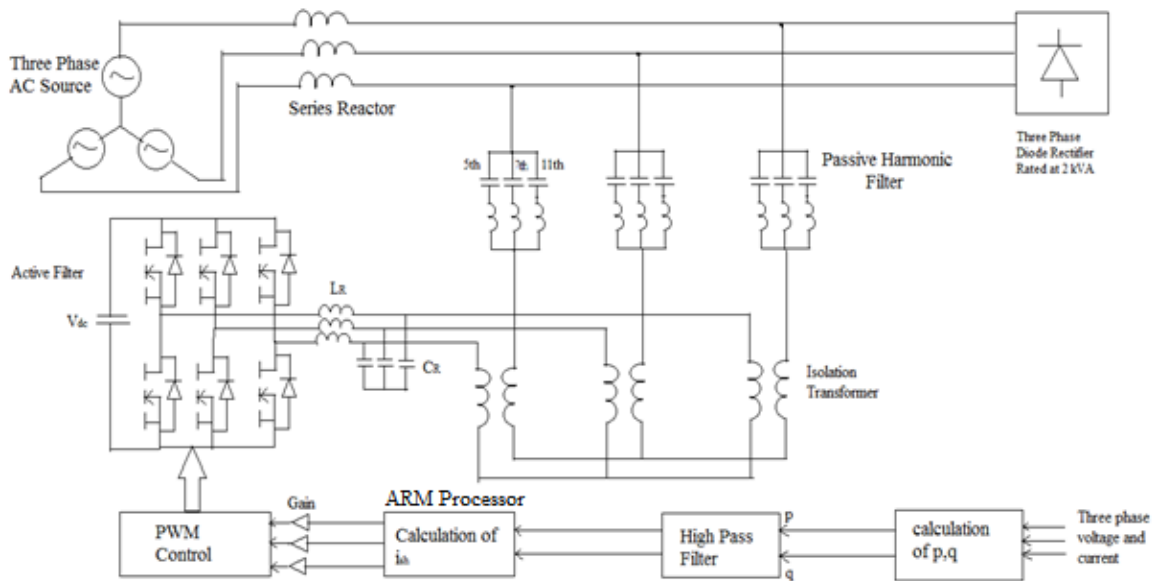

Fig. 3 Proposed system configuration

3.1 Converter Section:

The proposed system incorporates the series connection of active and passive harmonic filters that act as hybrid harmonic filter. The proposed hybrid system is verified on the three phase diode bridge rectifier rated at 2.2kW, that is acting as a nonlinear load. The schematic diagram of three phase diode bridge rectifier is shown in Figure 1

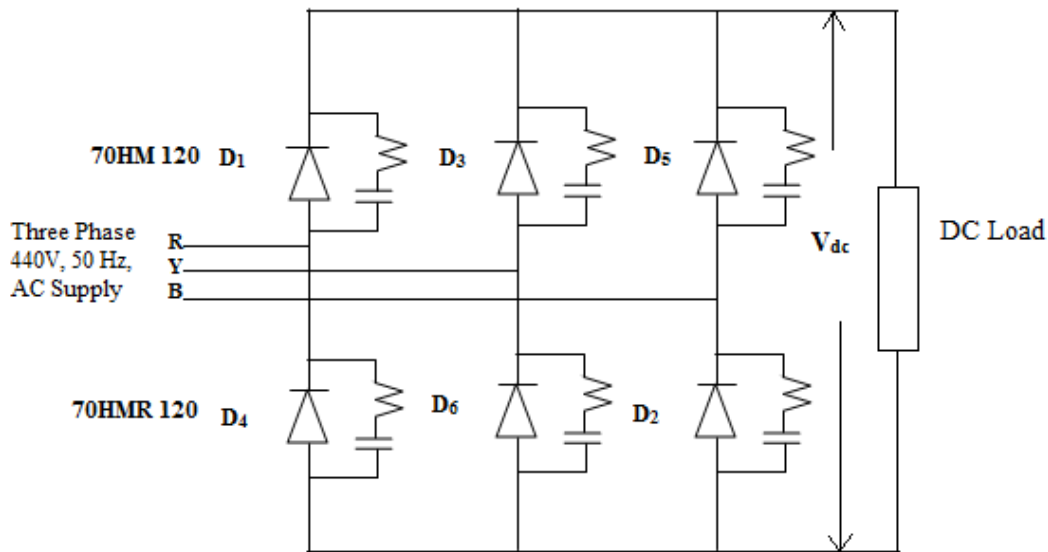

Fig 4 Schematic diagram of three phase diode bridge rectifier

Six Power diodes (70HMR120-3; 70HM120-3) are used to form the three phase diode bridge rectifier. It has the maximum current rating of 70A and maximum peak forward voltage of 1.35V. 70HM 120 denotes the diode with normal polarity and 70HMR 120 denotes the diode with reverse polarity. Miniature Circuit Breaker (MCB) of rating 100A is used to trip the circuit whenever the line to neutral fault occurs.

3.2 Passive Harmonic Filter – Parameter Design:

The three phase diode bridge rectifier is first analyzed without the implementation of filter. From the analysis it is observed that the harmonics of order 5th, 7th and 11th are most dominating. Hence the Passive harmonic filter is designed for those dominating orders [18]. The parameter of Passive harmonic filter is tabulated in Table 1.

Table 1 Parameters of Passive Harmonic Filter

Order	L(mH)	C(μf)	Reactive Power (kVAR)
5 th	10.40	38.99	2.0026
7 th	5.202	39.78	1.9981
11 th	2.0808	40.28	2.0011

A three phase PWM inverter is acting as active filter. PWM signal for active filter circuit is generated with the help of ARM processor.

3.3 Active Harmonic Filter Control Technique:

The control signal to the active filter is generated by using the Instantaneous Reactive Power Theory and is shown in Figure 5. The p-q theory defines a set of instantaneous powers in the time domain. Since no restrictions are imposed on voltage or current behaviors, it is applicable to three phase systems with or without neutral conductors, as well as to generic voltage and current waveforms. Thus, it is not only valid in steady states but also valid in transient states. Contrary to other traditional power theories treating a three phase systems as three single phase circuits, the p-q theory deals with all the three phase at the same time, as a unity system.

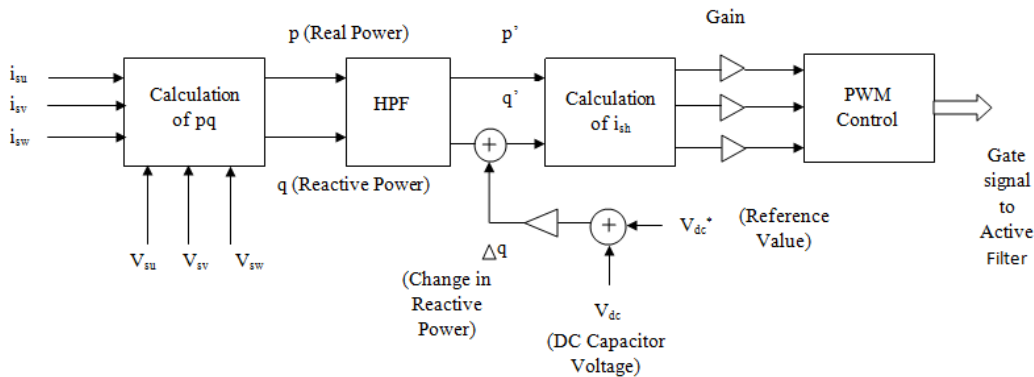

Fig. 5 .Block diagram of gate signal generation to the Active filter

In the proposed work the active filter is controlled by instantaneous reactive power theory. The instantaneous reactive power theory, or the so called “p-q theory” was introduced by Akagi, Kanazawa and Nabae in 1983. The p-q theory defines a set of instantaneous powers in the time domain. Since no restrictions are imposed on voltage or current behaviors, it is applicable to three phase systems with or without neutral conductors, as well as to generic voltage and current waveforms. Thus, it is not only valid in steady states but also valid in transient states. Contrary to other traditional power theories treating a three phase systems as three single phase circuits, the p-q theory deals with all the three phase at the same time, as a unity system. Therefore this theory always considers three phase systems together, not as a superposition or sum of three single phase circuits. It was defined by using the $\alpha\beta$ -transformation, also known as Clarke transformation, which consists of a real matrix that transforms three-phase voltages and currents into the $\alpha\beta$ - stationary reference frames. This theory is explained as follows.

$$\begin{bmatrix} e_\alpha \\ e_\beta \end{bmatrix} = \frac{1}{\sqrt{3}} \begin{bmatrix} 1 & -1/2 & -1/2 \\ 0 & \sqrt{3}/2 & -\sqrt{3}/2 \end{bmatrix} \begin{bmatrix} e_u \\ e_v \\ e_w \end{bmatrix} \quad (10)$$

$$\begin{bmatrix} i_\alpha \\ i_\beta \end{bmatrix} = \frac{1}{\sqrt{3}} \begin{bmatrix} 1 & -1/2 & -1/2 \\ 0 & \sqrt{3}/2 & -\sqrt{3}/2 \end{bmatrix} \begin{bmatrix} i_u \\ i_v \\ i_w \end{bmatrix} \quad (11)$$

$$\begin{bmatrix} p \\ q \end{bmatrix} = \begin{bmatrix} e_\alpha & e_\beta \\ -e_\beta & e_\alpha \end{bmatrix} \begin{bmatrix} i_\alpha \\ i_\beta \end{bmatrix} \quad (12)$$

$$\begin{bmatrix} i_{hu} \\ i_{hv} \\ i_{hw} \end{bmatrix} = \frac{1}{\sqrt{3}} \begin{bmatrix} 1 & 0 \\ -1/2 & \sqrt{3}/2 \\ -1/2 & -\sqrt{3}/2 \end{bmatrix} \begin{bmatrix} e_\alpha & e_\beta \\ -e_\beta & e_\alpha \end{bmatrix}^{-1} \begin{bmatrix} p' \\ q' \end{bmatrix} \quad (13)$$

$$V_c^* = K^* i_{sh} \quad (14)$$

Where,

e_u, e_v, e_w = Three phase ac source voltages

i_{su}, i_{sv}, i_{sw} = Three phase ac source current

p', q' = signal contains harmonic content alone (Extracted from high pass filter)

The p-q theory provides a very efficient and flexible basis for designing control strategies and implementing them in the form of controllers for power conditioners based on power electronic devices. This theory defines the instantaneous real and imaginary power is a flexible tool not only for harmonic compensation but also for reactive power compensation. The real and reactive power (p&q) are generated by the analog circuit and the harmonic currents are extracted from the real and reactive power with harmonic content by applying the reverse Clarke transformation. This harmonic current extraction is done with the help of ARM Processor by using the following algorithm.

3.4 Simulation Waveforms:

The basic equation of Clarke transformation helps to convert the three phase quantity (e_u, e_v, e_w) into two phase quantity (e_α, e_β) is given as follows. The alpha co-ordinate can be generated by the following equation.

$$e_\alpha = \frac{2}{3} \left[e_u - \frac{e_v}{2} - \frac{e_w}{2} \right] \quad (15)$$

The voltage magnitude e_v is given to the one input of differential amplifier (U1.A) through the potential divider circuit and another input is given directly from terminal e_u . The output of the differential amplifier U1.A is given as input to another differential amplifier circuit (U1.B) the second terminal is fed by e_w through the potential divider circuit. The output of the second differential amplifier circuit is gained using another OP-AMP in order to get multiplication with $\sqrt{2/3}$. The simulation of this circuit is verified through the Proteus Software, which is a software exclusively used for Printed Circuit Board design and electronic circuit simulation. The simulation diagram is shown in Fig 6. After alpha co-ordinate will be lesser than the three phase magnitude since it is multiplied with $\sqrt{2/3}$. The simulated output is verified and is shown in Fig 7.

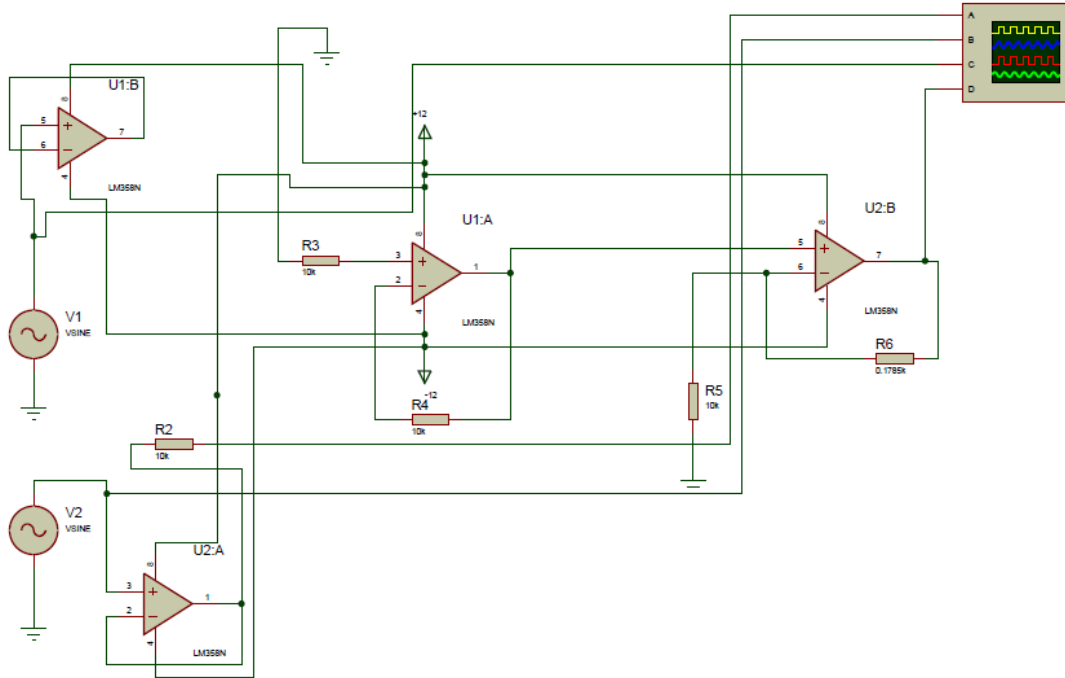

Fig 6 (a)

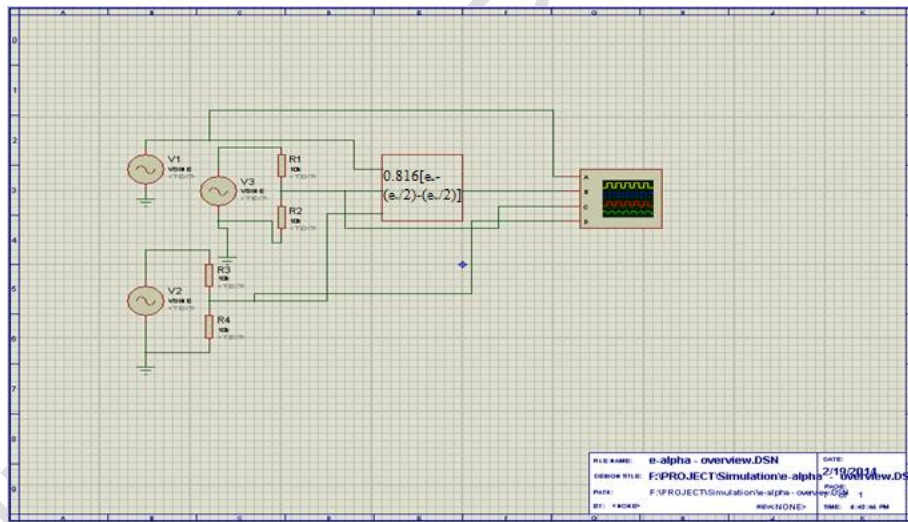

Fig 6 (b)

Fig 6 Generation of alpha coordinate (e_α) signal
 (a) Circuit diagram (b) Simulation circuit using Proteus software

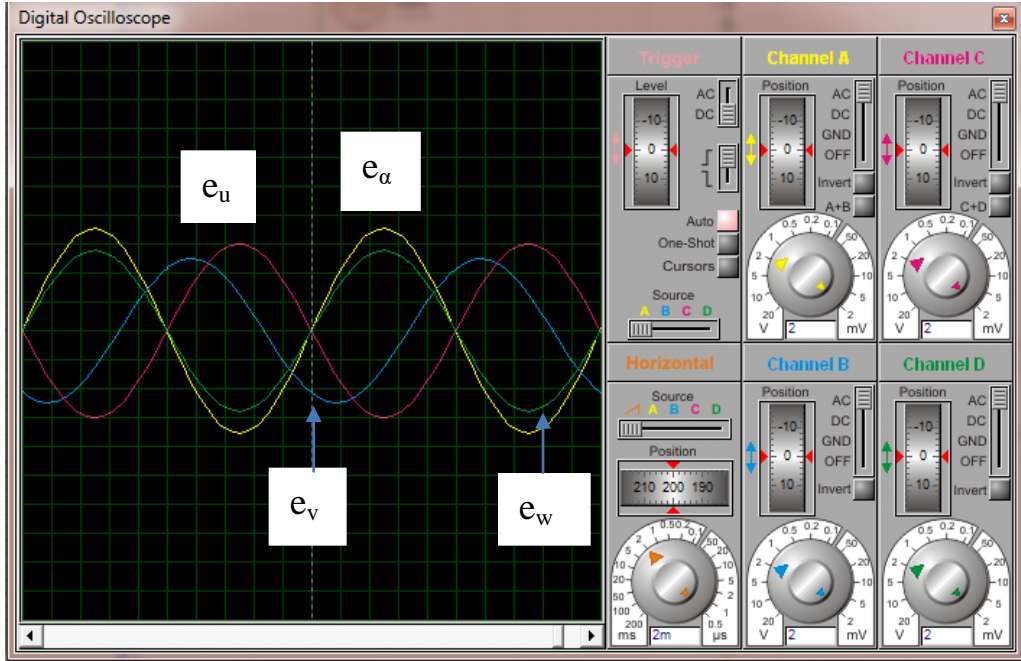

Fig 7 Simulation output wave form for alpha coordinate (e_α) signal

Similarly the simulation and output waveform for the generation of e_β is given in Figure 8 and 9 respectively. The beta co-ordinate Can be generated by the following equation.

$$e_\beta = \frac{1}{\sqrt{2}} [e_v - e_w] \quad (16)$$

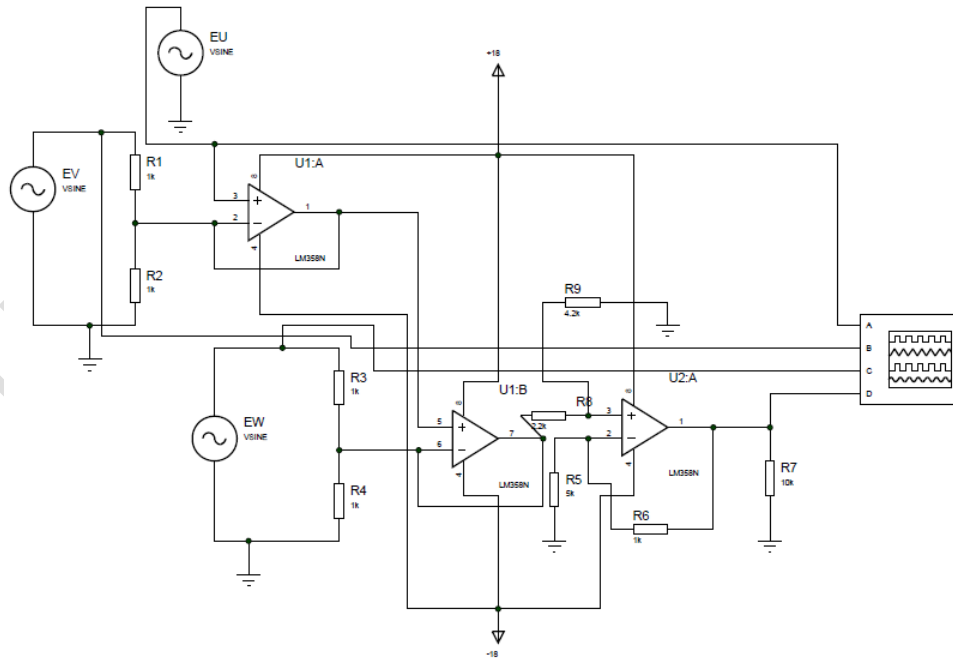

Fig 8 (a)

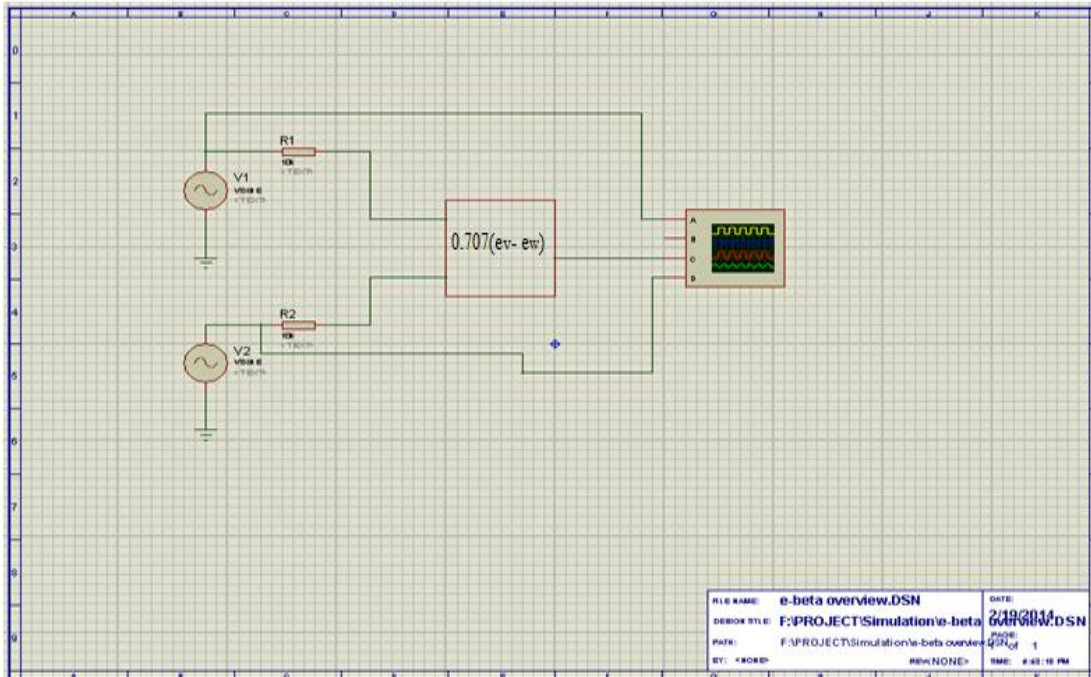

Fig 8 (b)

Fig 8 Generation of beta coordinate (e_β) signal
 (a) Circuit diagram (b) Simulation circuit using Proteus software

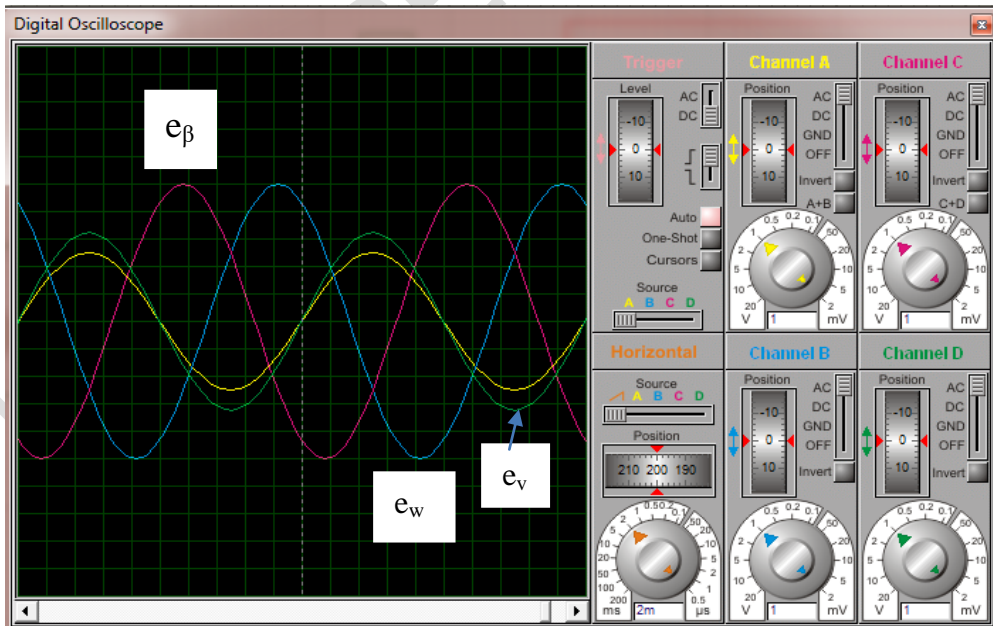

Fig 9 Simulation output wave form for beta coordinate (e_β) signal

The instantaneous real and reactive power can be obtained by multiplying the voltage and current generated after applying the Clarke transformation. The multiplication is performed by using MC1495 IC. The equation of real and reactive power is shown as follows.

$$P = (e_{\alpha} * i_{\alpha}) + (e_{\beta} * i_{\beta}) \quad (17)$$

$$Q = (e_{\alpha} * i_{\beta}) - (e_{\beta} * i_{\alpha}) \quad (18)$$

The harmonic current extraction is done with the help of ARM Processor.

3.5 ARM Processor:

In this proposed system, an ARM processor is used as the central processing unit which takes decisions by applying the circuit parameters extracted by the analog sensing circuit into a self-formulated algorithm. The chosen processor model is an ARM Cortex M3 running on the Arduino platform, called 'Arduino Due'. The Arduino platform is chosen due to the fact that Arduino is an open source platform which offers a robust development environment. It has an additional dedicated microcontroller ATmega16U2 for serial communication and ISP which means that the board can be plugged into any PC with 'Arduino Integrated Development Environment (IDE) installed to start programming the controller directly. This 32 bit ARM processor is clocked at about 84MHz. It is capable of processing 4 byte wide data in a single clock, also possessing the famous thumb-2 instruction set features. It also has a built-in DMA controller, which can relieve the processor from performing memory intensive tasks. The architecture of the chosen version of the ARM processor (Cortex-M3) is highly suitable for the proposed work. This high speed capability would enable the line parameters to be sampled instantaneously and the processing can be done in almost real-time.

3.6 Proposed Algorithm:

The instantaneous reactive power theory is utilized to generate the gate signals to the active power filter. The algorithm for this theory is described below .

Step 1: Initialize the controller working parameters

Step 2: Sense the real power (P), reactive power (Q), real power with harmonic content (P') and reactive power with harmonic content (Q') from ADC pins

Step 3: Store it in different variables (p1,q1,p2 & q2) as follows

- Store P in p1
- Store Q in q1
- Store P' in p2
- Store Q' in q2

Step 4: Apply the formula for extracting the harmonic current component (i_{shu} , i_{shv} , i_{shw}) from real and reactive power with harmonic content (p',q') which is already discussed in 3.4

$$i_{shu} = \sqrt{\frac{2}{3}} \frac{1}{e_{\alpha}^2 + e_{\beta}^2} [e_{\alpha} p2 - e_{\beta} q2] \quad (19)$$

$$i_{shv} = \frac{1}{\sqrt{6}} \frac{1}{e_{\alpha}^2 + e_{\beta}^2} \{ [\sqrt{3} (e_{\beta} p2 + e_{\alpha} q2)] - (e_{\alpha} p2 - e_{\beta} q2) \} \quad (20)$$

$$i_{shw} = \frac{-1}{\sqrt{6}} \frac{1}{e_{\alpha}^2 + e_{\beta}^2} \{ [\sqrt{3} (e_{\beta} p2 + e_{\alpha} q2)] + (e_{\alpha} p2 - e_{\beta} q2) \} \quad (21)$$

Step 5: Map and constrain the resultant value to the required 10 bit PWM limit.

Step 6: Output the PWM signal to the IGBT driver circuit.

The extracted current signal is converted into the voltage by multiplying with the gain value. This voltage waveform is now compared with the triangular waveform for generating the gate signal to the Active filter. The output of the Active filter is connected in series with the passive harmonic filter through the coupling transformers with the ratio of 1:10 to match the

voltage-current rating of the active filter with that of the passive filter. After that the harmonic current is amplified by gain value K , it is given as input to the PWM Controller as a voltage reference.

4. RESULTS AND DISCUSSIONS:

An experimental prototype of the proposed Hybrid Harmonic Filter was implemented and tested for a six-pulse diode bridge rectifier (converter) acting as a nonlinear load. The voltage source inverter is connected in series with the passive filter through the coupling transformer, acting as a hybrid harmonic filter. The active filter is connected in series with the passive harmonic filter, to improve the characteristics of the passive harmonic filter. The passive filter was tuned at the 5th, 7th, and 11th order harmonic frequencies, which are dominating orders produced by the converter system. The experimental results before and after implementation of the hybrid harmonic filter are discussed in this section under different loading conditions of the nonlinear load (converter). The proposed research was carried out under real-time analysis during the year 2014.

4.1 Analysis of Converter System without Harmonic Filter:

A three phase diode bridge rectifier is considered as harmonic producing load which is rated at 2.2kW. The test system is analyzed under the normal condition in order to know the effect of harmonics incurred due to the nonlinear load by evaluating the Total Current Harmonic Distortion (THD_i) value. The experimental prototype of converter system without hybrid harmonic filter is shown in Figure 10. The three phase diode bridge rectifier is connected with the 10kW three phase resistive load, acting as a DC load to the three phase diode bridge rectifier.

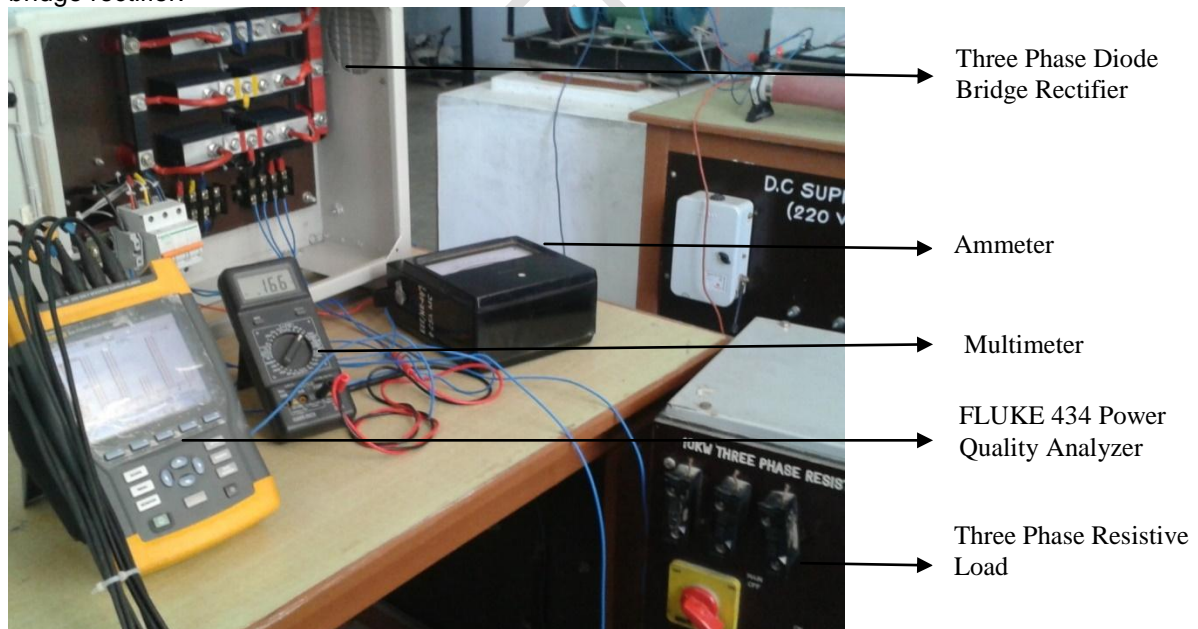

Fig 10 Experimental set up of three phase diode bridge rectifier (converter)

The three phase diode bridge rectifier is analyzed without the harmonic filter implementation using power quality analyzer and the results are analyzed. The current waveform and THD bar graph denoting the current harmonics are shown in Figure 11. It is observed that the current wave is critically distorted due to the harmonic produced by non-linear load (rectifier load), also from the bar graph it is evident that the 5th and 7th order current harmonics are

dominating. Hence the passive harmonic filter is designed for 5th and 7th order harmonics and it was implemented in the real time rectifier system. It is observed that the total current harmonic distortion (% THD_i) is 27.7%, this value is not a gratified value as per the IEEE 519-2014 standard. K-factor is also an important key factor which directly relates to how much the transformer is affected by nonlinear loads in terms of harmonic distortion, the transformer is considered at the point of common coupling (PCC) in an electrical system. Usefully, the k-factor is maintained as 1, means there is no current harmonic pollution in the supply system. In this proposed work, a three-phase rectifier is acting as a nonlinear load, which will produce waveform distortion leading to harmonic pollution, hence the measured K-Factor is 6.5.

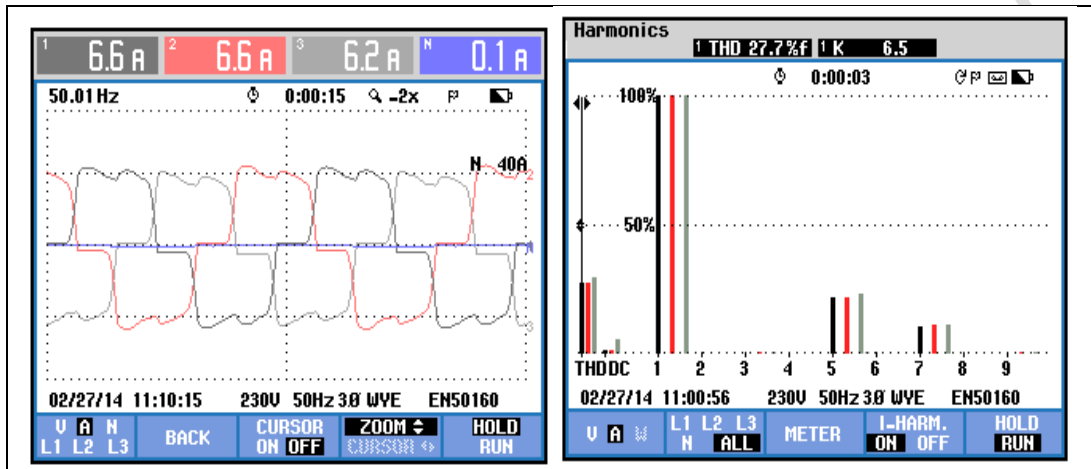

Fig 11. Current waveform and %THD_i bar graph of non-linear load (three phase rectifier) without filter

Table 2 Result of three phase diode bridge rectifier without filter

S.No	Name of the Parameter	Value
1.	Nonlinear Load Current (Amps)	6.6
2.	Nonlinear Load Real Power(kW)	2.19
3.	Nonlinear Load Reactive Power(kVAR)	0.17
4.	Nonlinear Load Apparent Power(kVA)	2.20
5.	Total Current Harmonic Distortion THD _i (%)	27.7

4.2 Analysis of Converter System with Harmonic Filter:

The three-phase converter system is now analysed with the implementation of a hybrid harmonic filter that is a series combination of passive and active harmonic filters. Passive harmonic filter parameters like inductor and capacitor are designed by using the equations (1) to (9) with respect to reactive power. Those inductors and capacitors are designed for their rated current and voltages respectively and are tabulated in Table 3. Passive harmonic filter parameters suppress distorted harmonic signals with respect to their tuned frequency.

Table 3 Passive Filter Parameters

Harmonic Order	Inductor (L) mH	Capacitor (C) μF	Reactive Power (KVAR)
5	10.40	38.99	2.0026
7	5.202	39.78	1.9981
11	2.0808	40.28	2.0011

The converter system is analyzed under four different loading conditions of the proposed converter system. The proposed hybrid harmonic filter is connected at the input side of the six pulse converter (non-linear load). The power quality analyzer is also connected at the point of common coupling (PCC), which is the common point between the three phase supply and the non linear load. Voltage and current for the converter are measured by using the appropriate voltage and current probes. The complete experimental set up of the proposed work with hybrid harmonic filter implementation is shown in Fig 12. From table 4, it can be observed that the Total Current Harmonic Distortion ($\%THD_i$) is reduced to a considerable value ($\%THD_i = 11.2\%$) even under the unbalanced condition, which shows the effectiveness of the proposed hybrid harmonic filter. The experimental results of the converter system with the implementation of a hybrid harmonic filter are given in Table 4 under 75% loading of the proposed converter.

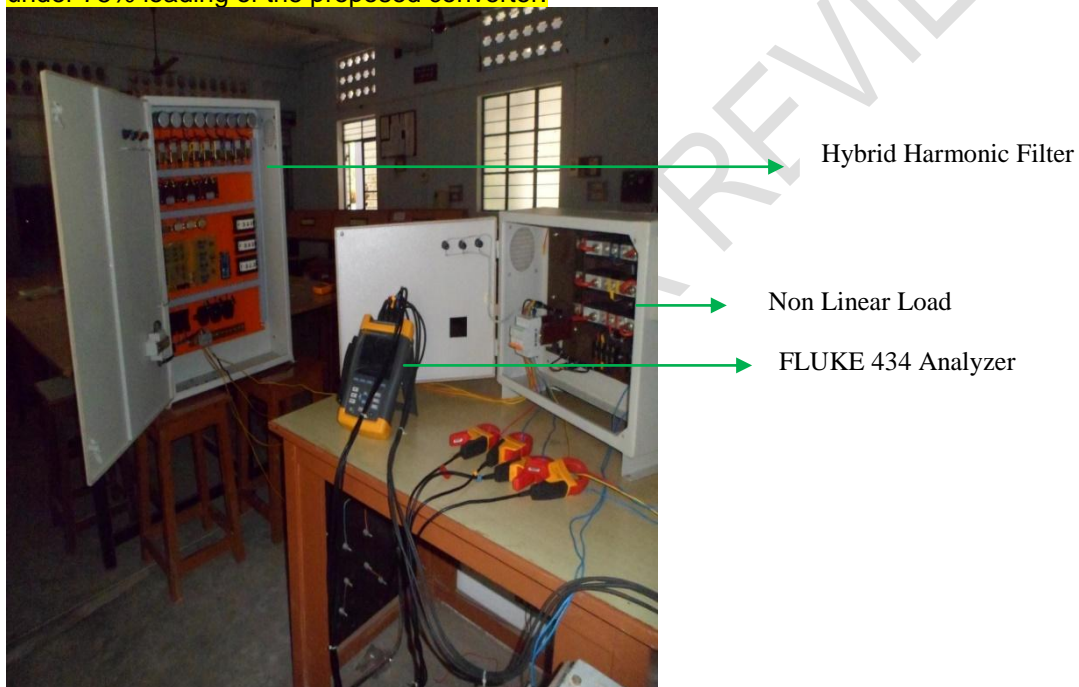

Fig 12 Experimental set up of the Non-linear load (three phase rectifier) with Hybrid harmonic filter

From the table 4, it can be observed that the Total Current Harmonic Distortion (THD_i) is reduced to the considerable value even under the unbalanced condition that shows the effectiveness of the proposed hybrid harmonic filter.

Table 4 Result of three phase diode bridge rectifier (converter 75 % loading) with filter

Sl.No	Name of the Parameter	Value
1.	Nonlinear Load Current (Amps)	7.1
2.	Nonlinear Load Real Power(kW)	2.9 kW
3.	Nonlinear Load Reactive Power(kVAR)	0.18
4.	Nonlinear Load Apparent Power(kVA)	2.26
5.	Total Current Harmonic Distortion THD_i (%)	11.2

The voltage waveform and current waveform after the implementation of hybrid harmonic filter is shown in Figure 13. From the figure it is observed that the effect of harmonics is minimized. Hence the voltage and current waveform is improved that depicts the effectiveness of the proposed hybrid harmonic filter.

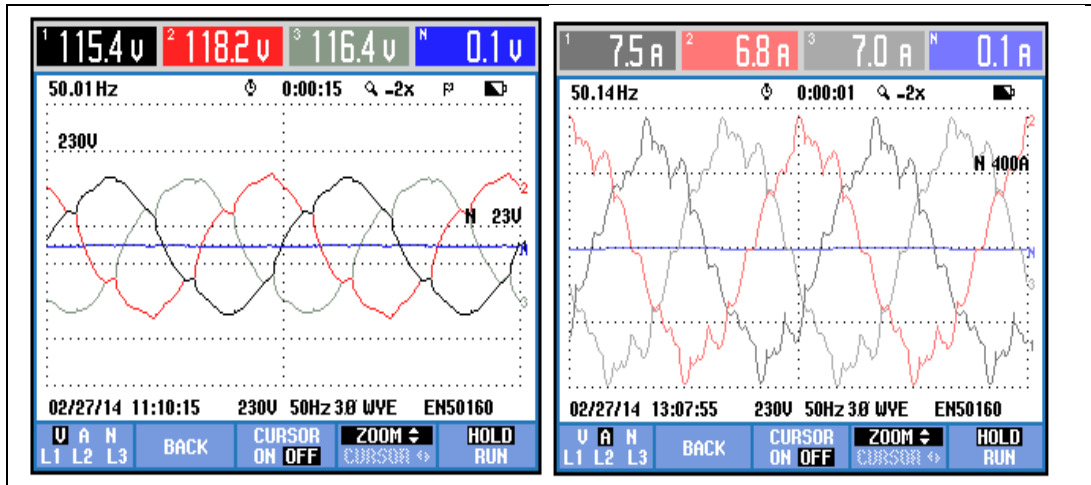

Fig 13. Voltage and Current waveform of Non-linear load (three phase rectifier) with hybrid Harmonic filter

The bar graph and individual order of current harmonics is shown in Fig 14. It is evident that the %THD_i is 11.2% measured under the hybrid harmonic filter is connected in the converter. But %THD_i is 27.7% is measured at input side of the converter system without implementing hybrid harmonic filter. Hence the %THD_i is reduced from 27.7% to 11.2% after implementing the proposed filter. From the figure, it is known that the 5th, 7th and 11th order harmonics are reduced to the considerable value which thereby reduces the effect of harmonics produced by nonlinear load after the implementation of proposed harmonic filter in the test system.

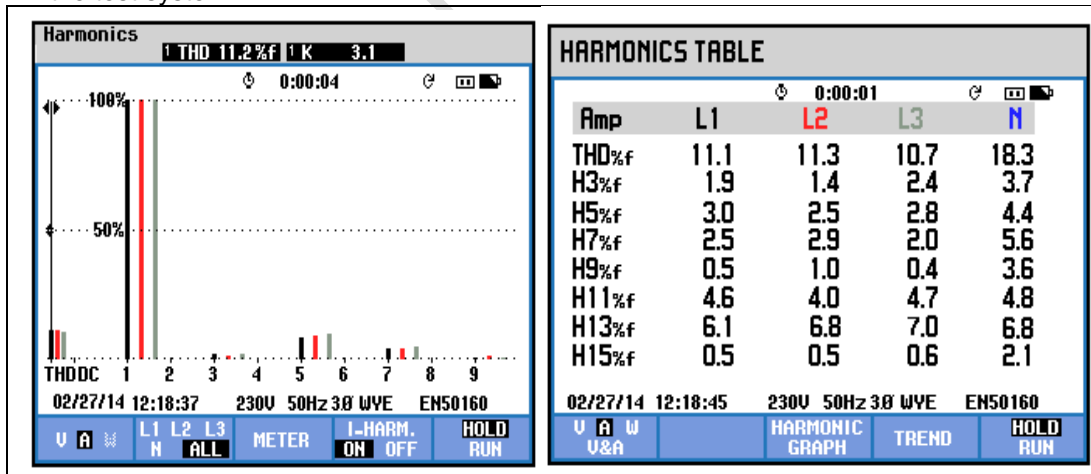

Fig 14. %THD_i bar graph and Individual order current harmonic values of non-linear load (three phase rectifier) with Hybrid Harmonic Filter

From the results, it can be concluded that the proposed hybrid harmonic filter is working efficiently to compensate for the current harmonics caused by the three-phased diode bridge rectifier acting as a nonlinear load. In order to know the efficacy of the proposed

system, the comparative analysis is done based on Total Current Harmonic Distortion (THDI) by testing the system with and without a filter under different loading conditions of the converter system, and the %THDI values are tabulated in Table 6.

Table 5 Comparative Analysis of the proposed system

Cases	%THDI	
	Before Hybrid Harmonic Filter Implementation	After Hybrid Harmonic Filter Implementation
Converter-30% Loading	29.2	12.3
Converter-60% Loading	28.6	11.8
Converter-75% Loading	27.7	11.2
Converter-100% Loading	26.9	10.8

7. CONCLUSION:

In nearly all industrial applications, converters are vital towards controlling the performance of the electrical equipment used in adjustable speed drives, un-interrupted power supplies, arc furnaces, direct current (DC) power transmissions, and renewable energy systems. But those converters create waveform distortion, which will lead to power quality issues in the power system. Hence, this proposed research article focuses on designing the passive harmonic filter and implementing the suitable control technique for an active harmonic filter. A hybrid harmonic filter is a combination of both passive and active filters. It is suitably designed and tested for a six-pulse rectifier system (converter) which acts as a nonlinear load.

The compensation performance of a hybrid filter, which is a series combination of active and passive harmonic filters, was presented and analyzed. The theory developed in the proposed work is verified analytically and experimentally. The feature of the proposed system is to use an active filter with a smaller rating than the conventional filters. The results of the experimental set up with the implementation of a hybrid harmonic filter clearly show that the current harmonic distortion (%THDI) is greatly reduced from 27.7% to 11.2% after implementing the hybrid harmonic filter at the input side of the converter, which shows the effectiveness of the proposed approach. Hence, the %THDI is maintained close to the limit specified by IEEE standard 519-1992. It is observed that the waveform shape is also improved after implementing the filter. Obviously, the k-Factor is also reduced from 6.5 to 3.1. The converter system is analyzed under different loading conditions. The proposed scheme not only reduces the current harmonics but also compensates for the reactive power simultaneously. Hence, the power factor of the proposed scheme is improved.

REFERENCES

1. M.H.J. Bollen, "What is power quality?", Electric Power Systems Research, Vol.66(2003),pp 5-14.
2. Partha S. Bhowmik and S.Sengupta, "Electric Power Quality in a Deregulated Power System: A Review", International Conference on Power Systems, ICPS (2004) , pp 83-88.
3. Ambra Sannio, Jan Svensson, Tomas Larsson, "Power-electronics solutions to power quality problems", Electric Power Systems Research, Vol 66(2003), pp 71-82.

4. Hideaki Fujita and Hirofumi Akagi , “ A Practical Approach to Harmonic Compensation in Power Systems – series connection of Passive and Active Filters” , IEEE Transactions on Industry Application , Vol 27 , No 6 , (1991) pp 1020 – 1025.
5. M.El – Habrouk , M.K.Darwish and P.Mehta , “ Active power filters : A review” , IEEE proceeding on Electric Power Application , Vol 147 , No 5 , (2000) , pp 403-413.
6. Hirofumi Akagi , Yoshihira Kanazawa and Akira Nabae , “Instantaneous Reactive Power Compensators Comprising Switching Devices without Energy Storage Compensators” , IEEE Transactions on Industry Applications , Vol IA -20,No 3 (1984) , pp 625 – 631.
7. A.Van Zyl , J.H.R. Enslin , W.H.Steyn and R.Spee , “ A New Unified Approach to Power Quality Management” , IEEE , 1995.
8. Fang Zheng Peng , Hirofumi Akagi and Akira Nabae , “ A New Approach to Harmonic Compensation in Power Systems – A Combined System of Shunt Passive and Series Active Filters” , IEEE Transactions on Industry Application , Vol 26 , No 6 , (1990) , pp 983 – 990.
9. Fausto B.Libano, Jose A.Cobos and Javier Uceda , “ Simplified Control Strategy for Hybrid Active Filters” , Power Electronics Specialists Conference, Vol 2 ,(1997) pp 1102-1108.
10. Darwin Rivas, Luis Moran, Juan Dixon, Jose Espinoza, “A Simple Control Scheme for Hybrid Active Power Filter” , Power Electronics Specialists Conference, Vol 2,(2000) , pp 991-996.
11. Subhashish Bhattacharya, Po-Tai Cheng, Deepak M.Divan, “Hybrid Solutions for improving Passive filter performance in High Power Applications” , IEEE Transaction on Industrial Applications, Vol 33, No 3(1997), pp 732-747.
12. Tugse Demirdelan, Mustafa Inci, Cagatay Bayindar, “ Review of Hybrid Active Power Filter topologies and controllers” , 4th International Conference on Power Engineering, Energy and Electrical Drives, pp 587-592.May 2013.
13. Chi-Seng Lam, Man-Chung Wong, Wai-Hei Choi, Xiao-Xi Cui, Hong-Ming Mei, Jian-Zheng Liu, “ Design and Performance of Low-DC-Voltage-Controlled LC-Hybrid Active Power Filter With a Neutral Inductor in Three-Phase Four-Wire Power Systems” , IEEE Transactions on Industrial Electronics, Vol 63, No 6, June 2014, pp 2635-2647.
14. Ahmed Faheem Zobaa, “ Optimal Multiobjective Design of Hybrid Active Power Filters Considering a Distorted Environment” , IEEE Transactions on Industrial Electronics, Vol 63, No 1, January 2014, pp107-114.
15. Salvador P. Litran, Patricio Salmeron, “Reference Voltage Optimization of a Hybrid Filter for Nonlinear Load Compensation” , IEEE Transactions on Industrial Electronics, Vol 63, No 6, June 2014, pp 2648-2654.
16. Salem Rahmani, Abdelhamid Hamadi, Kamal Al-Haddad, Louis A. Dessaint, “A Combination of Shunt Hybrid Power Filter and Thyristor-Controlled Reactor for Power Quality” , Vol 63, No 5, June 2014, pp 2152-2164.
17. S. Rahmani, Ab. Hamadi, Ab. Hamadi, A.I. Alolah, “A DSP Based implementation of an instantaneous current control for a three-phase shunt hybrid power filter” , Electric Power Systems Research (2013) pp 229–248.

18. Roger C.Dugen, Surya Santoso, Mark F. Mc Granaghan and H. Wayne Beaty, "Electrical Power Systems Quality", McGraw Hill Professional (2002).
19. S.Parthasarathy and E.Jeyasri, "Harmonic Distortion Evaluation And Reduction In Radial Distribution System", International Journal of Innovative Research in Science, Engineering and Technology, *Volume 3, Special Issue 3, March 2014*, ISSN (Online) : 2319 – 8753, pp 113-117.

UNDER PEER REVIEW