

Original Research Article

Battery cells and a super-capacitor bank storage system: Design trend and strategies for renewable power applications

Abstract

The variability of critical load demands has led to an increasing push for a clean, sufficient and reliable power supply. Employing innovative techniques to address this need, is a feat yet to be met by several developing nations. Inverter systems based on battery storage provide the extra energy supply to these loads, due to the unavailability of the general power supply. Nevertheless, discharging/charging values of energy demands at peak levels notably affect the performance of batteries. Interestingly, an integrated energy system incorporating power and energy densities of high value can be supplied by combining batteries and other storage devices, in this context super-capacitors (SC). In light of the above, this paper presents the hybrid combination of battery cells and a super-capacitor bank storage system, highlighting its design as well as performance assessment aimed at improving the battery's life span and its performance while on-load. A novel automatic switching system (ASS) is incorporated to establish a parallel connection between the battery and SC. The ASS detects energy signals from either source of power considered and engages the battery/super-capacitor hybrid system, either to charge or serve as a source of energy to the load. The results show that a significant initial value of transient current is supplied by the super-capacitor. The current draw at peak level is drastically reduced on the battery. This also results in economical savings in cost and increased reliability, which has been necessitated in the backup energy market.

Keywords: Automatic switching system, Battery storage system, Hybrid energy storage system, Photovoltaic system, Renewable energy, Super-capacitors.

List of Abbreviations

AC	Alternating current
ASS	Automatic switching system
ATM	Automatic teller machine
BSH	Battery/super capacitor hybrid system
CAES	Compressed air energy storage
DC	Direct current

EDLC	Electric double layer capacitor
ESS	Energy storage system
EV	Electric vehicle
FC	Fuel cell
HESS	Hybrid energy storage system
HRES	Hybrid renewable energy system
LIB	Lithium-ion battery
MOV	Metal oxide varistor
PHS	Pumped hydro storage
PV	Photovoltaic
PUS	Power utility source
SC	Super-capacitor
SMES	Superconducting magnetic energy storage
SPICE	Simulation Program with integrated circuit Emphasis,

1. Introduction

Presently, there is a necessity to supply reliable, clean and sufficient energy to loads critical in nature. As such, a secondary reserve power system has become increasingly important in meeting this demand [1]. Ordinarily, support systems depend largely on batteries as a storage medium, but a higher system may utilize a generator set. Nevertheless, each technology has its peculiar flaw. Specifically, batteries as a storage system present discharge proficiency of high value, but at increased load current, the proficiency decays rapidly with their rate capacity outcome [2, 3]. The design and development of a rechargeable storage system with high power and energy densities coupled with a longer life span are of boundless significance [4]. A novel technology super-capacitor is ideally suited to the market for reserve power systems. Employed as combined or hybrid energy sources such as super-capacitor and battery systems are depicting a new wave of backup energy of higher dependability and increased reliability. Without reacting synthetically, an Electric double-layer capacitor (EDLC) also known as a super-capacitor can store energy [5].

Applications of this improving super-capacitor technology cannot be overemphasized as they find relevance in numerous fields. Augmenting the principal power source, the super-capacitor provides a swift burst of power, unlike other sources. The future looks good for super-capacitors, a powerful

alternative energy resource that ranks already. The variability of loads coupled with a current draw at maximum level in fuel cells must be minimized. Largely, super-capacitors are employed to reduce load current fluctuations in batteries. A parallel hybrid connection of super-capacitors with a battery results in an energy storage system, which can supplement the discharging current at a higher rating, owing to the high power density possessed by super-capacitors. Consequently, minimizing the effect of the rate capacity impact. The super-capacitor behaves like a refiner that reduces great stresses on the battery under irregular load conditions [6].

In this context, this paper presents a hybrid configuration comprising a Li-ion type battery and a bank of super-capacitors to realize an integrated energy storage system aimed at optimum improvement of battery life span and energy capabilities while offering re-usability and linkage to separate cells at lower levels. In light of the above, a novel ASS is fabricated to set up a parallel linkage between the battery and super-capacitor. Furthermore, this research is aimed at boosting the inverter storage system, incorporating a combined super-capacitor/battery storage system. The depletive nature and adverse impact of fossil fuels on the surroundings, coupled with the expensive cost of grid energy are drawbacks that have impelled the exploration of alternative power systems. Additionally, this study finds relevance in areas requiring continual auxiliary energy, which leads to the concept of the novel model, an automatic switching system controlled super-capacitor/battery hybrid storage system. The main contribution of this paper is outlined as follows:

- a. design a novel ASS, for battery cells and a super-capacitor bank hybrid storage system;
- b. analysis and simulation of the hybrid energy storage system design; and
- c. development and assessment of the established hybrid energy storage system.

1.1 Overview of energy storage systems

A new road map of hybrid technology is emerging, to eradicate to a minimal level, the issues of irregular and insufficient electricity supply; numerous hybrid energy systems have been introduced and examined in literature [7-13]. Nonetheless, different versions of energy storage, such as batteries [14], compressed air energy storage (CAES) [15], flywheels [16], hydrogen fuel cells [17], pumped hydro storage (PHS) [18], super-capacitors [19], and superconducting magnetic energy storage (SMES) [20] can be employed. The important attributes of each energy storage are depicted in Table 1.

Table 1. The important features of different energy storage systems [21].

Characteristics	Efficiency	Technological maturity	Cost	Energy density	Power density
Battery	75-85%	Mature	Low	High	Low
CAES	70%	Mature	High	High	High
Flywheel	80-90%	Mature	Low	Low	High
Hydrogen	50-60%	Early-stage of maturity	High	Depends on the hydrogen reservoir	Depends on the speed of reaction
PHS	75-85%	Mature	High initial cost	Depends on the size of the reservoir	Depends on the height and distance between reservoirs
SMES	90-95%	Immature	High	Low	High
Super-capacitor	80-95%	Immature	High	Low	High

CAES although quite cheap requires underneath the earth, compressed-air storage caverns. For efficiency and lower cost, the flywheel is recommendable but is limited due to its drawback of the high rate of discharge. Smaller energy applications employing the PHS is not acceptable due to their large system initial cost. Batteries are an excellent solution form of storage for HRES as they are capable of yielding high energy storage at a lower cost [21]. The expectancy rate depicts the continual evolvement of technology in the future to broaden its applicability and reduce cost. However, storage energy technology is vital for power stability and constant supply to meet load demands. In time past, most research on battery/super-capacitor hybrid systems has been geared towards energy strategy management and electric vehicular applications, with an emphasis on the analysis of different temperature and battery prices for optimal sizing and feasibility of HESS. But this research emphasized tackling critical loads and how effectively the battery/super-capacitor hybridization can be an innovative candidate to handle the ever-rising need for backup power. Motivated by the limitations of the stand-alone storage system, various hybrid storage system solutions have gained traction in academia and industry.

Battery/supercapacitor hybrid system (BSH): Advances in technological research suggest it will be beneficial to have a single energy system which constitutes both high specific energy and power. Batteries are unique due to their quality of having high energy density, but their capabilities are limited due to their low specific power. Further, super-capacitors constitute high power density, but also possess a drawback of low energy density. Previous studies [22,23] showed connecting a super-capacitor to a battery is feasible, but the super-capacitor may hurt the battery in the absence of a proper control switching mechanism due to its high charging requirement. Furthermore, several

electronic and power devices have been employed to evaluate the viability of combining batteries in parallel with the super-capacitor, but to no avail, as some resulted in breaking the flow of energy between sources [24]. To this end, the active connection of these technologies with a proper switch mechanism like the novel ASS proposed in this paper, would realize an energy system where a high value of an initial current draw is supplied by the SC and subsequently supplemented by batteries as voltage level drops. **Fig. 1** depicts a comparison of different rechargeable type batteries incorporating BSH and EDLC storage options.

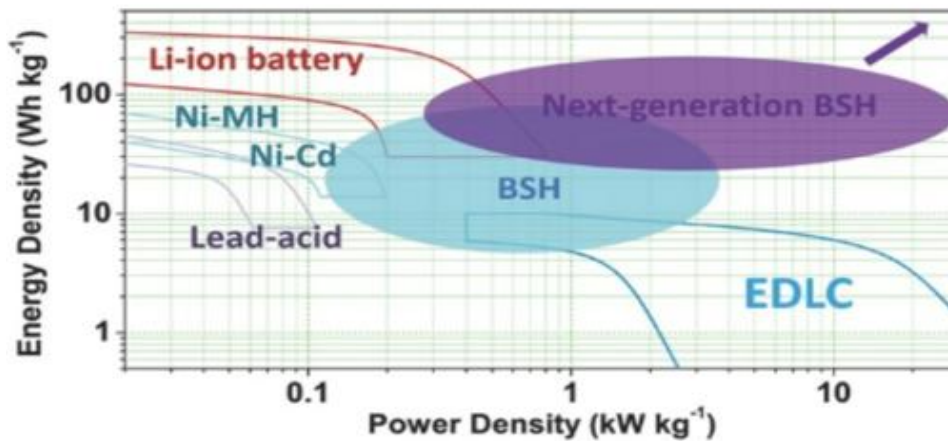

Fig. 1 comparison of different rechargeable type batteries incorporating BSH and EDLC storage options [4].

1.2 Reviewed articles related to this study

The hybrid configuration of the energy system in energy technologies is proving to gain increasing success, incorporating numerous hybrid systems. The authors in [22] conducted an in-depth analysis to determine the pulse power capability of batteries and SCs about the power usage time and experimental verification. A Lithium-ion battery with 44V, 11Ah, and an SC with 36V, 30F is employed. Compared to conventional methods, the proposed technique can provide a robust improvement in the performance and stability of storage systems, particularly when combined with the estimation of the battery's state of charge.

The authors in [19] remarked that although batteries have attracted significant research attention, the available batteries are not sufficient to supply the energy demands of electric vehicle power consumption due to rapid changes when the battery discharges and non-monotonic consumption of energy. To this end, a hybrid combination of batteries and SCs to meet the energy demands of an electric vehicle is considered. The SC is tasked with providing the excess energy to the electric vehicle in the event of battery failure to do so. A detailed review of previous findings in this direction is presented to inform future research decisions.

Xie et al. [25] provide a comprehensive overview of the fundamental structure of batteries and SCs. Specifically, the paper aimed at clarifying puzzles and confusion between batteries and SCs to further improve energy storage. A clear roadmap for further research is presented to guide researchers interested in this field of study.

The distinctive combination of fuel cell (FC) electric vehicles with a battery or SC is considered in [26]. The FC is designed to supply the primary power to the drive system whereas the battery or SC acts as the secondary source. Simulation results indicate that the combination of FC and SC provides superior performance since the SC can effectively handle the high charge and discharge current.

Tian et al. [27] opined that Graphene has emerged as a key candidate technology in material science to enhance the performance of Li-ion batteries and SCs. Thus, the authors characterized the various potential application aspects of Graphene for the optimized performance of Li-ion batteries and SCs. Moreover, current trends, research challenges are future research directions are highlighted.

The authors in [28] opined that there is a scarcity of studies addressing the area of electric vehicle (EV) storage systems. To this end, the technical feasibility and analysis of a battery/ultra-capacitor combination for EV active power control are proposed with the authors highlighting that the ultra-capacitor in HESS can address the dynamic load demand of low energy cars. Also, different dynamic loading situations were employed in the regulating method for the active power of low-powered EV with MATLAB/Simulink used to evaluate its performance. Furthermore, the DC-DC converter with different controlling plots for the battery and ultra-capacitor is inter-faced and is examined under different load conditions. Results obtained show that the proposed HESS active power scheme offers reliable and improved control, hence reducing the stress on the battery. Nonetheless, further research directions addressing the degeneration period of this study are highlighted.

Varying weather conditions have increased the dependency on the operation of separate PV systems for the storage of energy. In this context, Javed et al. [29] proposed the fabrication and examination of a battery/super-capacitor energy system utilizing a PV system for a rural location of Sultanpur, India employed as a case study. Further, a control scheme based on fuzzy logic is implemented to manage power directions to the super-capacitor and battery using meteorological data obtained from the case study area. The results obtained depict the strategy adequately controlling the power flow of HESS. Still, future research direction would be to investigate the efficacy of the proposed Fuzzy logic strategy by evaluating important hardware.

Li et al. [23] hinted that the crucial challenges impacting the power systems are the variability attributes of renewables and the inability of generated energy profiles to meet the load requirement. To this end, the authors proposed a super-capacitor/battery hybrid model based on a microgrid employed as a case study to examine the working compatibility of the scheme. Furthermore, the evaluation depicts the capability of super-capacitors in reducing the stress resulting from the discharge/charge profile of the system.

The optimal sizing of a PV system incorporating a super-capacitor for improved self-consumption and reduced grid fluctuation is proposed in [30]. A simple controller and inverter topology supply energy into the power system. The technical feasibility of the model is simulated, time stepped analysed with the effect of the electrical load taken into consideration. The results of power flow and energy self-utilisation for a single household, with the system increasing (from 53% to 100%) in initial self-consumption as super-capacitors increases by 16, while partly cloudy days (36%-80%) for increment in 10 super-capacitors.

An investigative study of the most cost-effective battery/super-capacitor combined storage system is proposed in [31]. An energy system comprising a battery and super-capacitor for the hourly supply of solar energy to a 1MW PV array is investigated using 3 different fuzzy logic algorithms to find increment factors for each dispatching period of the reference grid power estimation. Further, the impact of solar cell temperature and ambient temperature on yearly amount calculations of HESS is evaluated. The results depict a realized cost of 1.45€/kWh at a 30s filter time constant of four different days of input data from the solar cell, more analysis using increased days for solar input data and higher simulation soft tools are required.

Authors in [32] considered the viability of realizing a combined storage system comprised of batteries of lead-acid type and super-capacitors for full-electric forklifts. In light of the above, a well set up power strategy for HESS to the forklift was established to assist the battery. Compared to conventional methods, the proposed technique depicts a wider range of improvements in the performance and stability of storage systems, particularly when combined with handling the load variability demand of the forklift.

2. Methods

The methodology employed for this study comprises deep research from previous work on hybrid energy storage systems to realize the set aims as outlined as follows:

1. specification and design of an automatic switching system for battery cells and a super-capacitor bank hybrid storage system, employing hardware electronic components which work based on circuit theorems such as Kirchhoff and Ohms laws;

2. simulation of the system design employing LTSpice XVII software;
3. implementation of the design circuit employing appropriate components; and
4. performance assessment of the designed system model was carried out experimentally.

2.1 Design and setting of the study

Fig. 2 depicts the block schematics of the battery/super-capacitor hybrid storage model.

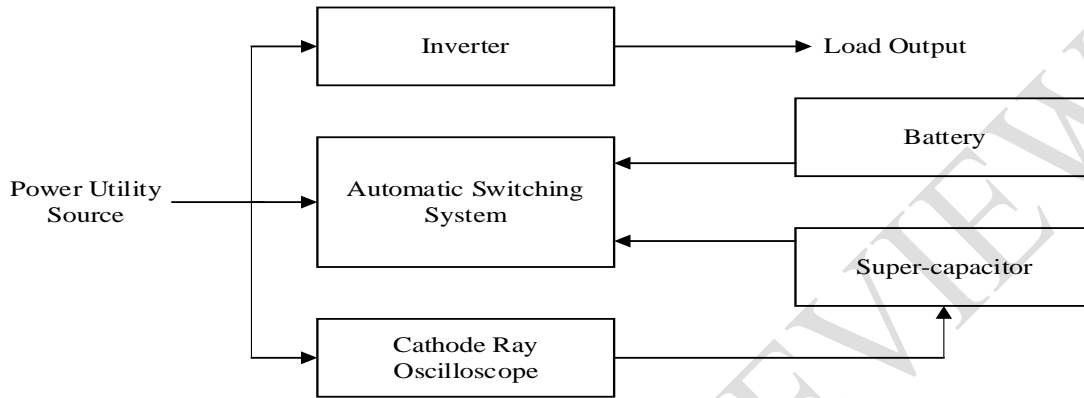

Fig. 2 Block schematics of the designed super-capacitor/battery hybrid storage model.

In the context of this design, a series connection mode is adopted to realize a 16.2V, 83.33F from the combined six super-capacitors of 2.7V, 500F. Further, for the proper technical feasibility of this hybrid model a lone cell 100Ah, 12V was employed, along with an inverter whose specifications are shown in Table 2.

Table 2 Inverter specifications.

Parameters	Values
Rating	2kVA
Frequency	50Hz
No. of phases	Single
Voltage at the input terminal (DC)	12V
Voltage at the output terminal (AC)	230V

Automatic switching system: A novel switching mechanism known as the Automatic switching system is fabricated to connect and disconnect the super-capacitor and battery when energy signals are/or are not detected. The various unit of the ASS is shown in the block architecture (Fig. 3).

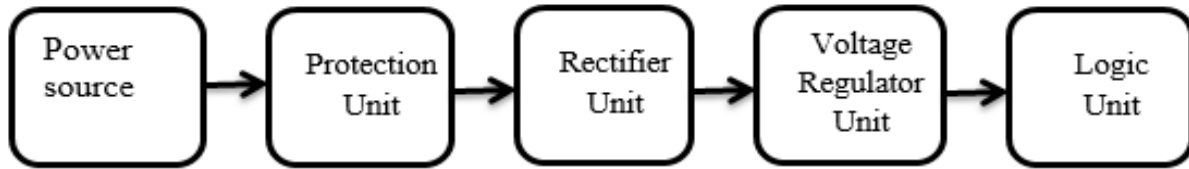

Fig. 3 Block architecture of the ASS.

2.2 Simulation

LTspice simulation software: An excellent simulation tool LTspice software is utilized to evaluate the feasibility of this parallel connection of the battery and super-capacitor with the aid of the ASS. The LTspice is a massive upgrade from the traditional SPICE simulator, with improved parallel integral processing, object code production, and spontaneous assembly in the SPARSE matrix solver.

Design Specification: Table 3 depicts the design specification parameters for this study.

Table 3. The design specification parameters for this study.

Parameters	Values
Filament bulb rating	400W
Electric motor rating	373W
Voltage of battery	12V
The chosen capacity of the battery	100Ah
Chosen voltage of super-capacitor	2.7V
The voltage of the super-capacitor bank	16.2V
Chosen super-capacitor capacity	500F
Sum Farad rating of super-capacitors	83.33F

Fig. 4 shows the circuit layout of LTspice XVII established in the model.

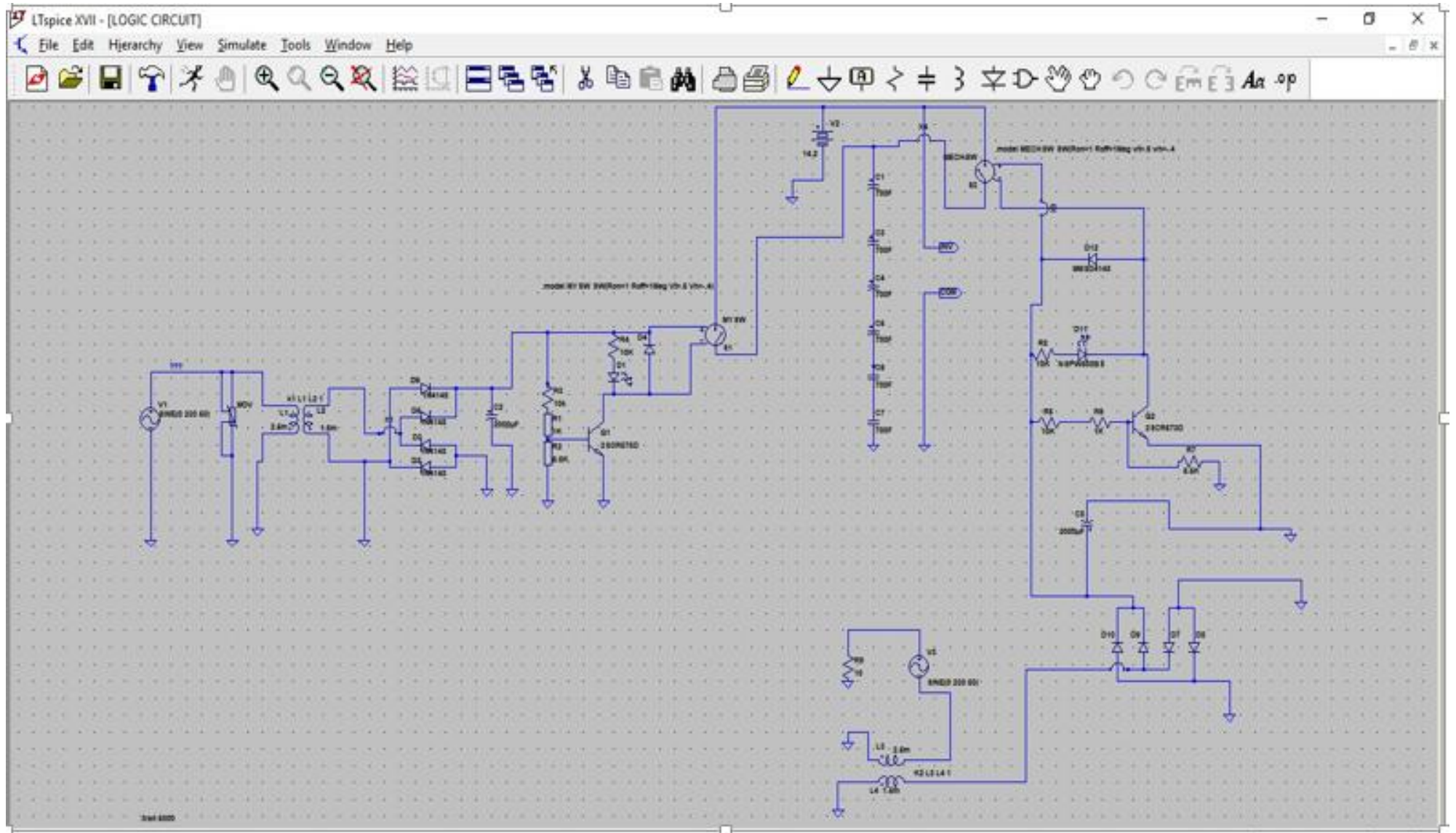

Fig. 4 Circuit layout of LTspice XVII established in the model.

2.3 Investigational Setup

Fig. 5 shows the graphic outlook of the investigational arrangement.



Fig. 5 Graphic outlook of the investigational arrangement.

A 2kVA inverter is employed for the investigational test, with aim of assessing the performance of various units under load while the charge rate of super-capacitor t obtained initial draw of current ($I = 6.75A$) by the load ($P = 400W$), the resistance (R) in ohms is calculated as follows:

$$R = P / I^2 \quad (1)$$

The formula employed for the rated discharge of the super-capacitor is shown;

$$t = -\log (V / E)(RC) \quad (2)$$

3. Results and Discussion

Fig. 6 shows the fabricated switching system. While Table 4 depicts the measurement result taken to regulate the super-capacitors charge rate.



Fig. 6 Developed ASS cross-sectional view.

Table 4 Super-capacitor charge rate measurements.

Parameters	Values
Battery initial voltage	13.20 V
Super-capacitor (SC) initial voltage	0.60 V
Full charge voltage of SC	12.92 V
Voltage of Battery after SC becomes completely charged	12.93 V
Total time for SC to be completely charged	13:06 min

Table 4 shows a considerable improvement as it took the SC barely 13:06 min for a full charge, highlighting that when before the battery discharges up to 50%, the SC can sufficiently compensate thus acting as a battery equalizer due to its rapid rate time of charge.

Table 5 Measurements of the battery as a standalone source for an inductive load test.

Parameters	Values
Initial battery voltage	12.73V
Final battery voltage	12.51V
Initial current drawn	6.13A

Table 5 shows the discharge tendencies of battery cells while handling inductive loads, since nearly half the voltage is initially drawn when connected to the load, stating the need for the super-capacitor bank to supply most of the initial current drawn as well as improve the battery life span.

Table 6 shows that there's an increased current draw of about 0.72V on the hybrid energy storage system, however more of the initial current drawn is supplied by the SC rather than the battery. For the resistive load test using a filament bulb in Tables 8 and 9, observations show that extra current is observed to be drawn employing the hybrid system than the battery as a lone source. The simulation waveform results acquired are shown in **Figs. 7 – 11**.

Table 6. The inductive load test measurements of the super-capacitor/battery hybrid system

Parameters	Values
Hybrid system voltage at the initial level	12.79V
Current drawn at the initial level	6.85A
Hybrid system final voltage	12.53V

Table 7. Resistive load test results employing battery as a single source

Parameters	Values
Battery voltage at the initial level	12.86V
Current drawn at the initial level	2.14 A
The final voltage of the battery	12.56V

Table 8. Resistive load test results employing the hybrid super-capacitor/battery as a source

Parameters	Values
Hybrid system voltage at the initial level	12.90V
Current drawn at the initial level	2.46A
Hybrid system final voltage	12.64V

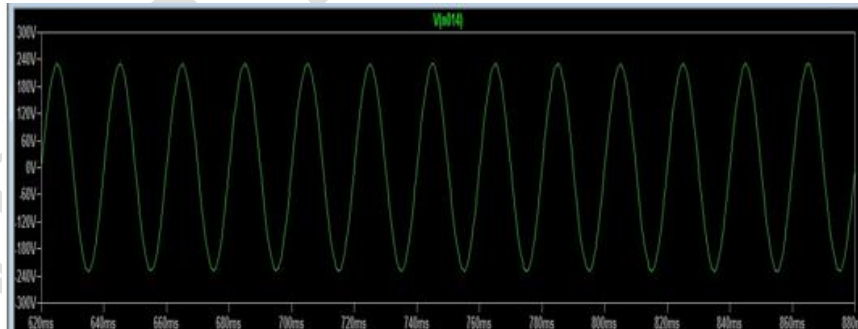

Fig. 7 The obtained input voltage waveform.

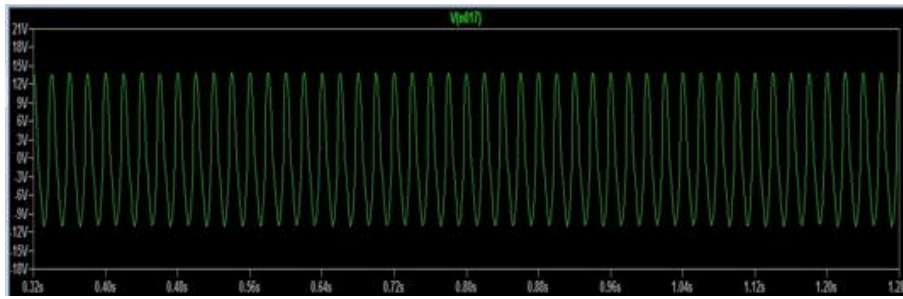

Fig. 8 Obtained voltage waveform after transformation.

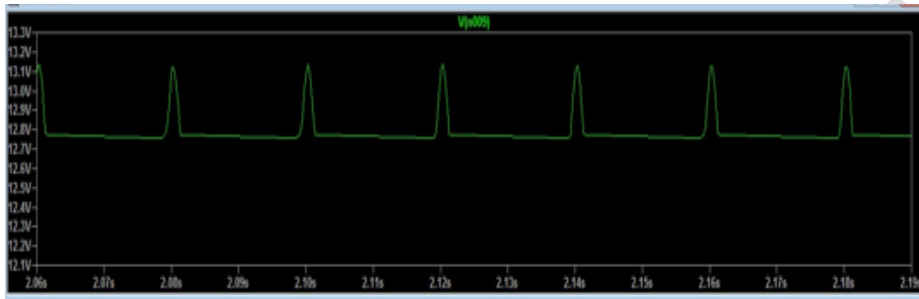

Fig. 9 The output voltage waveform after rectification.

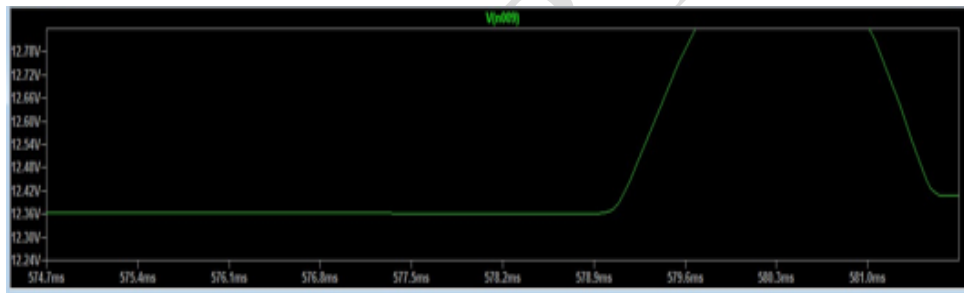

Fig. 10 The output voltage waveform after filtering.

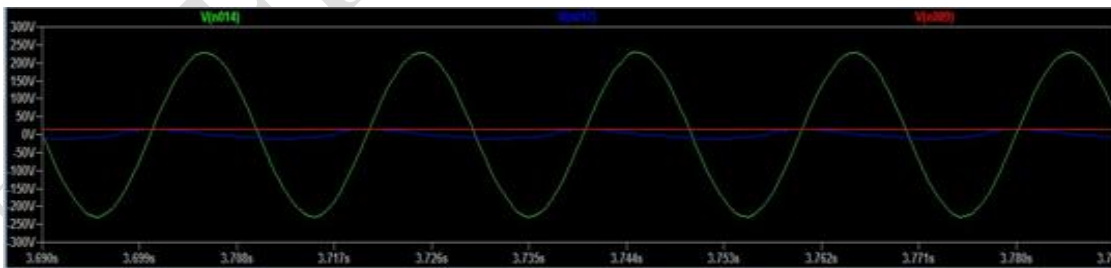

Fig. 11 The joint input is transformed and the filtered voltage waveform.

From observations (Figs. 7 – 8), the joint input, transformed and the filtered voltage waveform on the oscilloscope possess alternating features, while the output voltage waveform after rectification (Fig. 9) does not depict a pure direct current owing to superimposes ripples on the output voltage. However,

Fig. 10 is the natural DC voltage due to the filtered ripples. Furthermore, (Fig. 11) depicted a transformed voltage possessing alternating characteristics with a negligible amount of ripples.

3.1 Outcomes of the study

In the context of this study certain findings were observed as highlighted:

1. Due to alterations in the supply voltage, it was observed that the output waveforms of the inverter are not perfect sine waves as depicted in the oscilloscope.
2. there exists a reliance on the combined battery cells and super-capacitor storage bank amount of charge on the inverter charging current and consequently, this dependency has a direct proportionality.
3. the high current drawn by the inductive load is adequately controlled by the parallel hybridization of the battery and super-capacitor storage system.

In light of the above findings, traditional research geared towards the improvement of the battery life span for various applications can be improved as this model efficiently helps in the handling of inductive load and its high start-up current. In addition, the findings of this study thus have a positive impact and breakthrough in PV based battery/super-capacitor hybrid systems and this can consequently be further reassessed and then applied to electric vehicular applications, flywheel/battery hybrid systems, etc.

3.2 Limitations of the study

Despite the success of this study owing to the exciting findings revealed, each design and research has its pros and cons. Further, concerning this study limitations encountered are highlighted:

1. The system efficiently powered the load, however, has a drawback of being restricted to the battery-super capacitor rating, consequently it becomes more expensive if additional loads are required to be power-driven; and
2. In the context of this paper after evaluation, it is somewhat difficult to detach the battery cells and the super-capacitor bank while the inverter system is not operational, as, in due time when the super-capacitor is not charged it may act as a capacitive load on the battery draining its energy.

4. Conclusion

A battery/super-capacitor hybrid system has been proposed with a novel design of an automatic switching system to address problems of backup power supply to the critical load. Based on the experimental results obtained from our study, this paper presented a model, experimental setup,

analysis, design and challenges presented by the understudy hybrid storage system. Moreover, the viable load applications are outlined, and an up-to-date review of key findings and limitations of this study on existing research with research trends in hybrid energy storage are also presented. Further, the research relevance and improvements on traditional hybrid systems are highlighted and further success in the performance evaluation of BSH (battery/super-capacitor hybrid) systems are outlined as follows:

1. The battery lifespan could be extended as a result of reduced ripple current and voltage of the battery which consequently eases the effect of transient discharging/charging;
2. The realized system boosts high-cost savings and reliability owing to reduced system energy loss; and
3. In variation to the stand-alone battery system, the hybrid system offers an improved run time resulting in an energy enriched system, specifically at greater peak energy demand.

Furthermore, this novel cost-effective hybrid system with increased savings of over 50%, and improved run time of about 3.5h for a 400W load compared to the traditional battery as a stand-alone system which runs less than 3h, can be further explored and applied to this exciting area of hybrid energy storage systems.

5. Recommendation

The study opined the development of a novel automatic switching system, but from examination, the hybrid system does not give an account of how the initial current supplied can be measured separately from the battery and SC. Consequently, for further research within this scope, sufficient actions should be put in place to ascertain how the currents can be separately measured.

Competing Interest

The authors declare that there is no conflict of interest regarding the publication of this paper.

References

- [1] X. Wang, D. Yu, S. Le Blond, Z. Zhao, P. Wilson, "A novel controller of a battery-supercapacitor hybrid energy storage system for domestic applications," *Energy and Buildings*, vol. 141, pp. 167-174, 2017.
- [2] M. S. Okundamiya, A. N Nzeako, "Energy storage models for optimizing renewable power applications," *Journal of Electrical Power Engineering*, vol. 4, no. 2, pp. 54-65, 2010.

- [3] M. S. Okundamiya, S. T. Wara, H. I. Obakhena, "Optimization and techno-economic analysis of a mixed power system for sustainable operation of cellular sites in 5G era," *International Journal of Hydrogen Energy*, vol. 47, no. 39, pp. 17351-17366, 2022.
- [4] W. Zuo, R. Li, C. Zhou, Y. Li, J. Xia, J. Liu, "Battery-super capacitor hybrid devices: Recent progress and future prospect," *Journal of Advanced Science*, vol. 7, no. 1600539, 2017, <https://doi.org/10.1002/advs.201600539>
- [5] D. Shin, Y. Kim, Y. Wang, N. Chang, M. Pedram, "Constant-current regulator-based battery-supercapacitor hybrid architecture for high-rate pulsed load applications," *Journal of Power Sources*, vol. 205, pp. 516-524, 2012.
- [6] D. O. Akinyele, R. K. Rayudu, "Review of energy storage technologies for sustainable power networks," *Sustainable Energy Technologies and Assessments*, vol. 8, pp. 74-91, 2014.
- [7] M. S. Okundamiya, V. O. A. Akpaida, B. E. Omatahunde, "Optimization of a hybrid energy system for reliable operation of automated teller machines," *Journal of Emerging Trends Engineering & Applied Sciences*, vol. 5, no. 8, pp.153-158, 2014.
- [8] M. S. Okundamiya, O. Omorogiuwa, "Analysis of an isolated micro-grid for Nigerian terrain," 59th Int Midwest Symposium on Circuits & System Abu Dhabi, UAE, 2016.
- [9] Anurag Chauhan, R. P. Saini, "Techno-economic feasibility study on integrated renewable energy system for an isolated community of India," *Renewable and Sustainable Energy Reviews*, vol. 59, pp. 388-405, 2016.
- [10] M. Kim, D. Lee, J. Kim, "An optimization model for design and analysis of a renewable energy supply system to the sustainable rural community," *Energy Procedia*, vol. 136, pp. 342-348, 2017.
- [11] J. Jurasz A. Piasecki, "A simulation and simple optimization of a wind-solar –hydro micro power source with a battery bank as an energy storage device," *E3S Web of Conferences*, vol 14, 2017, <https://doi.org/10.1051/e3sconf/20171401017>
- [12] M. S. Okundamiya, C. E. Ojieabu, "Optimum design, simulation and performance analysis of a micro-power system for electricity supply to remote sites," *Journal of Communications Technology, Electronics and Computer Science*, vol. 12, pp. 6 – 12, 2017.
- [13] Y. Han, W. Chen, and Q. Li, "Energy management strategy based on multiple operating states for a photovoltaic/fuel cell/energy storage dc microgrid," *Energies*, vol. 10, no. 1, p. 136, Jan. 2017, <https://doi.org/10.3390/en10010136>
- [14] M. S. Okundamiya, J. O. Emagbetere, E. A. Ogujor, "Techno-economic analysis of a grid-connected hybrid energy system for developing regions," *Iranica Journal of Energy and Environment*, vol. 6, no. 4, pp. 243–254, 2015.

- [15] A. G. Olabi, T. Wilberforce, M. Ramadan, M. A. Abdelkareem, A. H. Alami, "Compressed air energy storage systems: Components and operating parameters – A review," *Journal of Energy Storage*, vol 34, p. 102000, 2021, <https://doi.org/10.1016/j.est.2020.102000>.
- [16] K. R. Pullen, "The status and future of flywheel energy storage," *Joule*, vol. 3, no. 6, pp. 1394-1399, 2019,
- [17] M. S. Okundamiya, "Integration of photovoltaic and hydrogen fuel cell system for sustainable energy harvesting of a university ICT infrastructure with an irregular electric grid, *Energy Conversion and Management*, vol. 250, p. 114928, 2021, <https://doi.org/10.1016/j.enconman.2021.114928>
- [18] S. Rehman, L. M. Al-Hadhrami, Md. Mahbub Alam, "Pumped hydro energy storage system: A technological review," *Renewable and Sustainable Energy Reviews*, vol. 44, pp. 586-598, 2015
- [19] L. Kouchachvili, W. Yaïci, E. Entchev, "Hybrid battery/supercapacitor energy storage system for the electric vehicles," *Journal of Power Sources*, vol. 374, pp. 237-248, 2018,
- [20] L. Chen, T. Zheng, S. MEI, et al., "Review and prospect of compressed air energy storage system," *Journal of Modern Power Systems and Clean Energy*, vol. 4, pp. 529–541, 2016.
- [21] S. Negi, L. Mathew, "Hybrid renewable energy system: a review," *International Journal of Electronics and Electrical Engineering*, vol. 7, no. 5, pp. 535-542, 2014.
- [22] S. Lee and J. Kim, "Power capability analysis of lithium battery and supercapacitor by pulse duration," *Electronics*, vol. 8, no. 12, 2019, <https://dx.doi.org/10.3390/electronics8121395>.
- [23] J. Li, B. Cornelusse, P. Vanderbemden, D. Ernst, "A SC/battery Hybrid Energy Storage System in the Microgrid," *Energy Procedia*, vol. 142, pp. 3697-3702, 2017.
- [24] B. K. Tan, N. M. L. Tan, A. K. Ramasamy, "Design of a battery-ultracapacitor hybrid energy – storage system with power flow control for an electric vehicle," *International Journal of Power Electronics and Drive System*, vol. 9, no. 1, pp. 286 – 296, 2018.
- [25] J. Xie, P. Yang, Y. Wang, T. Qi, Y. Lei, C. M. Li, "Puzzles and confusions in supercapacitor and battery: Theory and solutions, *Journal of Power Sources*, vol. 401, pp. 213-223, 2018
- [26] Q. Xun, Y. Liu and E. Holmberg, "A comparative study of fuel cell electric vehicles hybridization with battery or supercapacitor," 2018 International Symposium on Power Electronics, Electrical Drives, Automation and Motion (SPEEDAM), pp. 389-394, 2018.
- [27] J. Tian, Z. Yang, Z. Yin, Z. Ye, J. Wang, C. Cui, W. Z. Qian, "Perspective to the potential use of graphene in li-ion battery and super-capacitor," *Journal of the chemical record*, vol. 19, no. 7, pp. 1256-1262, 2019.
- [28] A. Kachawaha, G. I. Rashed, A. R. Garg, M. G. Hussein, "Design and performance analysis of hybrid battery and ultracapacitor energy storage system for electrical vehicle active power management," *Sustainability*, vol. 14, no. 2, p. 776, 2022, <https://doi.org/10.3390/su14020776>

- [29] K. Javed, H. Ashfaq, R. Singh, S. M. Suhail Hussain, T. Saleim Ustun, "Design and performance analysis of a stand-alone PV system with hybrid energy storage for rural India," *Electronics*, vol. 8, no. 9, p. 952, 2019, <https://doi.org/10.3390/electronics8090952>
- [30] M. Jaszczur, Q. Hassan, "An optimisation and sizing of photovoltaic system with supercapacitor for improving self-consumption," *Applied Energy*, vol. 279, p. 115776, 2020, <https://doi.org/10.1016/j.apenergy.2020.115776>.
- [31] P. K. Singha Roy, H. Bora Karayaka, Yanjun Yan, Yazan Alqudah, "Investigations into best cost battery-supercapacitor hybrid energy storage system for a utility scale PV array," *Journal of Energy Storage*, vol. 22, pp. 50-59, 2019.
- [32] F. C. Dezza, V. Musolino, L. Piegari, R. Rizzo, "Hybrid battery-super-capacitor system for full electric forklifts," *IET Electrical Systems in Transportation*, IET vol. 9, no. 1, pp. 16-23, 2019, <https://doi.org/10.1049/iet-est.2018.5036>