

Development and Performance Evaluation of a Mini-Potentiostat for Corrosion Experimentations

ABSTRACT

The exorbitant cost of laboratory equipment is chiefly responsible for the dearth of corrosion characterization equipment in material science laboratories of Universities from Sub-Saharan Africa and that of other developing countries across the globe. It has therefore become germane to exploit available resources for development of affordable potentiostat within the university community. In this work, detailed procedure and working principles for design, fabrication and performance evaluation of a portable and inexpensive microcontroller-based potentiostat are presented. PROTEUS® software was used for the design of the parent circuit board. Graphical User Interface (GUI) developed using Visual Studio and Origin PRO Software was used for acquisition of experimental results. Performance evaluation of the potentiostat was implemented by performing corrosion experiments in 5 wt.% NaCl solution using mild steel as a working electrode (WE). Ag/AgCl reference electrode (RE) was used as well as Platinum wire as the counter electrode (CE). The analysis of the working electrode potential against the log of current-density plot at a scan rate of 10 mV/s of the fabricated potentiostat revealed a Tafel plot that is in conformity with results from commercially available potentiostats.

Keywords: *Potentiostat, Corrosion, Mild Steel, Polarization*

1. INTRODUCTION

A potentiostat is an important tool in modern electrochemical research, particularly in the investigation of reaction mechanisms related to redox chemistry and other chemical phenomena. Its application in numerous fields of life, such as corrosion analysis, environmental monitoring, food and medication quality control, biosensors, chemical sensors, and protein sensors for waste dialysate [1], has greatly contributed to its rapid development. One area of relevant application of potentiostat in material science and mechanical engineering is generally corrosion analysis, which is of great concern in the industry and research. It was estimated that the global cost of corrosion

on metal usage in 2020 stands at \$2.5 trillion [2]. Consequently, researchers are working on predictive and control measures to minimize such metallic degradation and save lost.

Previous research shows that electrochemical corrosion test is a reliable method in corrosion testing at short time [3] and several corrosion studies have been made using the commercially available potentiostats [4]-[6]. However, there are challenges with the traditional designs of the corrosion testing tool. Potentiostats are currently manufactured by well-known corporations but are very expensive for personal research use as well as for purchase by researchers in developing countries. In addition, most of the manufactured potentiostats are not mobile because of their size, which is due to the circuit complexity that is frequently mandated by the intended use. Another area of concern about the commercially available potentiostats is that it outnumbers the users' practical and budgetary needs. As a result, several laboratories have begun to create their own potentiostats in order to meet their immediate needs while keeping costs to a bare minimum and ensuring effective performance in electrochemical analyses.

As a student laboratory exercise, [7] describes how to build a low-cost microcontroller-based potentiostat on a pinned circuit board. Both Cheap Stat [8] and D Stat [9] developed an open source potentiostat capable of being used in a wide variety of electrochemical procedures, including cyclic voltammetry. Another idea was the use of Arduino microcontroller boards, which expanded the capabilities of electronic controlled potentiostats, allowing for an expansion of the techniques that may be handled while keeping costs low [10]. Reference [11] also developed a low cost, simple and portable potentiostat with a relatively small dimension. They achieved this by building the controller circuit system using TLC2264 op-amp and ATMEGA32 microcontroller. In order to build implantable and dynamically programmable potentiostats, certain potentiostat designs have stressed compactness and reliability [12]. Other designs include a USB-controlled potentiostat for battery characterization [13], a polypotentiostat capable of performing electrochemical examinations of solutions via easily integrable data collection devices, and software that can be customized [14].

Though numerous portable and low-cost potentiostat designs have been made available [15]-[18], little attention has been paid to the design for corrosion assessment of metals and composite alloys. Hence, this paper presents a potentiostat based on a microcontroller (Atmega 8) for corrosion testing. The developed potentiostat will particularly be relevant for use in universities' material science laboratories in developing countries. Furthermore, the current design presented in this paper is intended for subsequent research on corrosion at the department of Mechanical Engineering, University of Ibadan, Nigeria.

2. MATERIALS AND METHODS

2.1 Potentiostat Design

The portable potentiostat consist of; (i) the MCU (ATMEGA8, Atmel, San Jose , CA) which serves as the central processing unit, distributing power and running all other functions; (ii) the Operational Amplifier (Op amp) Circuitry that serves as the heart of the potentiostat and serves as an interface between the MCU and the potentiostat electrodes; (iii) the User-Interface which was designed with Visual Studio Software and (iv) the Power Supply unit

which supplies all unit with required voltage with the help of the voltage-regulator. In Fig. 1, a schematic illustration of the potentiostat system is shown.

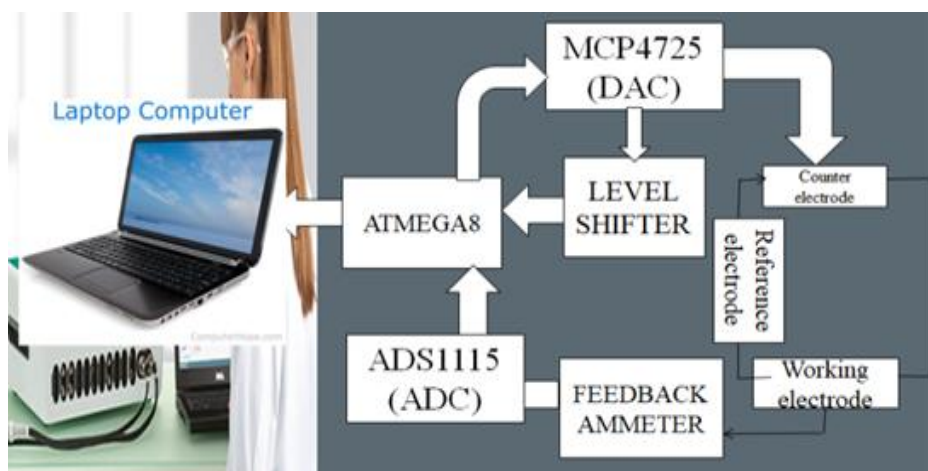

Fig. 1. Schematic Representation of the Potentiostat System

2.2 Hardware Design

The integrated potentiostat in Fig. 2 was designed and constructed as a simple laboratory research instrument for corrosion monitoring. The potentiostatic design was to conform to books of potentiostat Gopinath 2005 and Gamry 2010 standard. To meet these specifications, Proteus Software was used for circuitry design and simulation to verify the potentiostat with desire to have a potentiostat of high current and voltage output. The current range of ± 50 mA was fed into the circuitry, in which it was specifically designed to have an output current of $0.015 \mu\text{A}$. High power transformer was used to ensure sufficient power into the circuit. The power section was designed in a way that required power for different section is being accommodated with the help of voltage regulator. To determine the output voltage and current at the measurement section, a microcontroller (Atmega8), 16-bit ADC (AD1115), 12-bit DAC (MCP4725) and oscillator were incorporated into the circuit to avoid manual computation. The 16-bit ADC assists in converting analog signal from the circuit to digital signal which can be easily processed by the microcontroller. On the other hand, digital signal from the microcontroller is converted to analog signal by the 12-bit DAC which is then transferred to the circuit. Accuracy of the potentiostat was achieved by the Opamps introduced to serve different functions. In Fig. 2, Op-amp U6 was configured in such a way that it generates an inverted voltage signal of the same sign. Through the RE and electrolyte, this voltage signal is returned to the inverting input, producing the same amplified voltage signal but with the opposite sign. This is necessary to ensure that the Op-amp U6 is supplying the CE with the control voltage (U5:B). When the control voltage is applied to the CE, current flows from the CE to the WE through the electrolyte. The WE is polarized in such a way that the difference between its input and the RE input, is zero. This maintains the WE's potential exactly equal to that of the RE. The WE's potential can be adjusted manually using the potentiometer U7:A. To apply the WE potential, the RE's voltage is transferred through a

voltage follower (U4) and then added to the potentiometer's potential, resulting in an applied potential on the WE that is with respect to the RE.

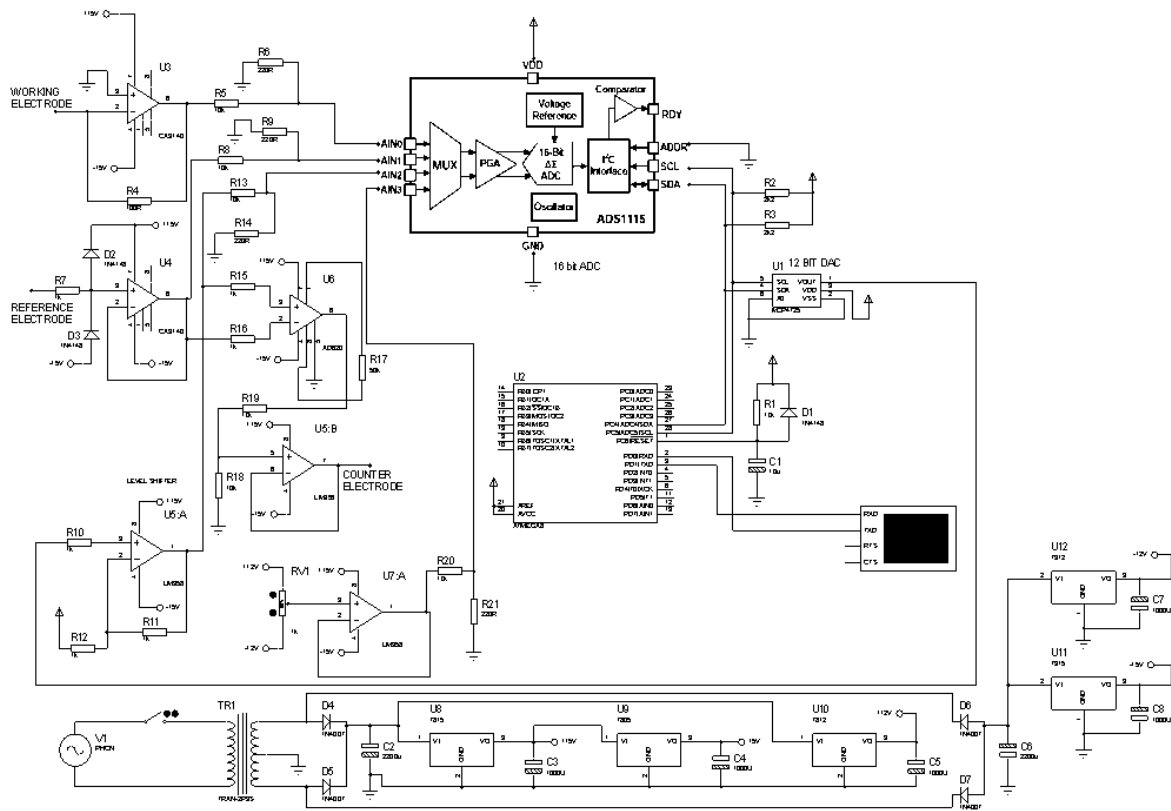

Fig 2. Circuitry Design of the potentiostat

2.3 Design of User Interface

For the GUI design, Visual Studio Software was used to write and compile the script. The potentiostat's output will be saved in a file that will be copied to Microsoft Excel for proper analysis. The user interface shown in Fig. 3 allows the user to input parameters like E-start, E-end, and Scan rate.

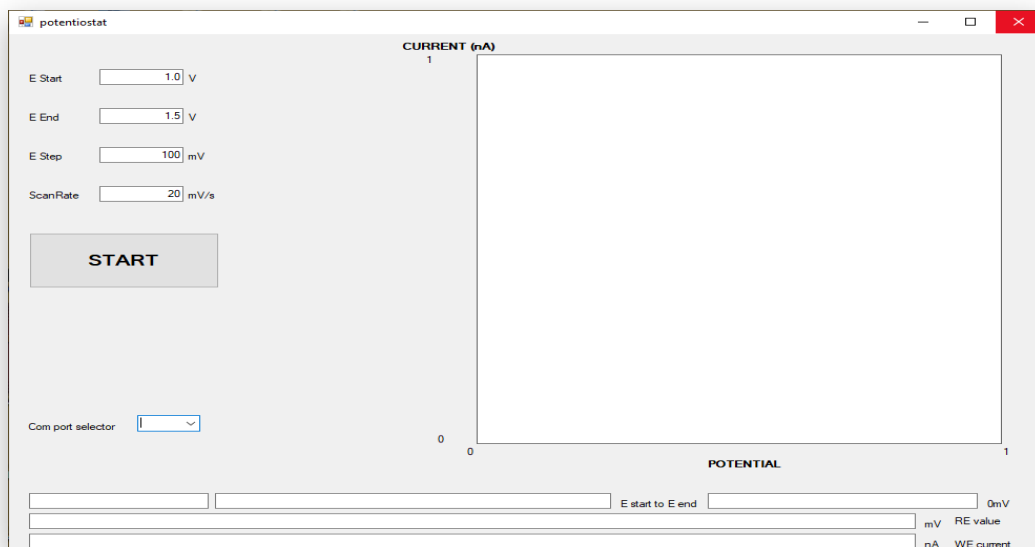

Fig. 3. User Interface of the potentiostat

UNDER PEER REVIEW

2.4 Working Electrode Preparation

The mild steel used for testing the potentiostat was 10 × 10 × 1.5 mm in dimension. Its chemical composition in weight (%) is shown in Table I. Emery paper of different grades used in the order of 90, 100, 120 and 180 were used to polish the mild steel and cleaned with acetone and washed with distilled water.

Table 1. Chemical Composition of Mild Steel

Element	C	Mn	Si	P	Al	S	Ni	Fe	Others
Wt%	0.1790	0.5826	0.1548	0.0459	0.0098	0.0594	0.1310	98.2476	0.5899

2.5 Electrochemical Tests

The mild steel was attached to a copper conductive wire and mounted with epoxy resin, exposed surface of about 100mm² of the mild steel was left to serve as the testing site. A 5 wt% Keephway® NaCl solution (pH = 6.7) with 99.5% purity, prepared with distilled water at room temperature, was used as the environment for the electrochemical test. The mild steel sample was introduced into the prepared solution and connected to the three-electrode developed potentiostat. The mild steel acted as a WE, with a Radelink® Platinum electrode acting as a CE and Radiometer Copenhagen® Ag/AgCl electrode as the RE. A scan rate of 10 mV/s and applied potential of ± 250 mV of the Open circuit potential were used during the experiment.

3. RESULTS AND DISCUSSION

The open circuit potential readings for mild steel after 900 seconds are shown in Fig. 4. From the plots, the OCP was obtained as - 0.756 V where the system became relatively stable. The current – potential curve and the Tafel plot for mild steel are shown in Figs. 5 and 6. The Tafel plots for the mild steel were obtained from experiments and manually extrapolated using Origin software to get the corrosion potential (E_{corr}) of 0.708 V and current density (I_{corr}) of 5.090 A/cm². This value was used to calculate the corrosion rate as 0.1890 mm/yr. This value obtained from the test was close to corrosion rates for mild steel [3][5][6].

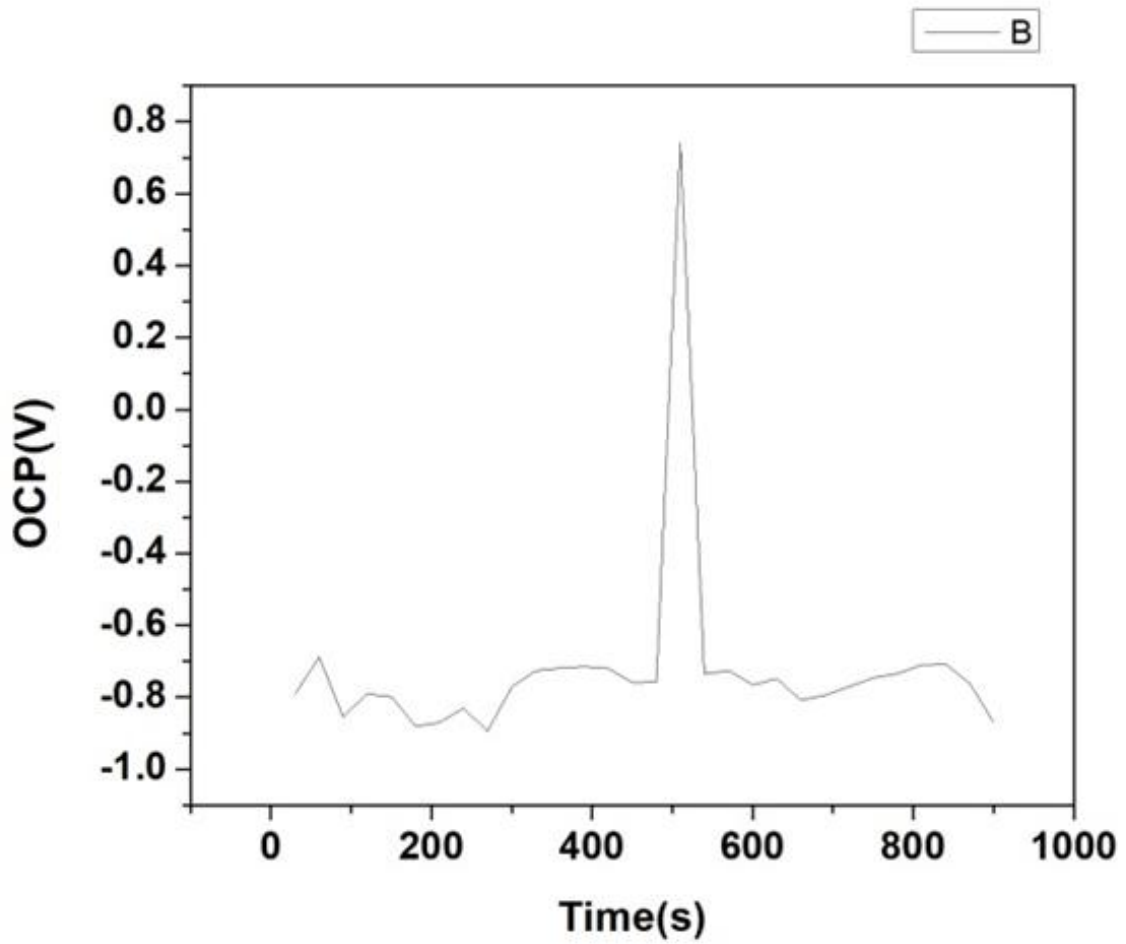

Fig. 4. Open Circuit Potential (OCP) against Time

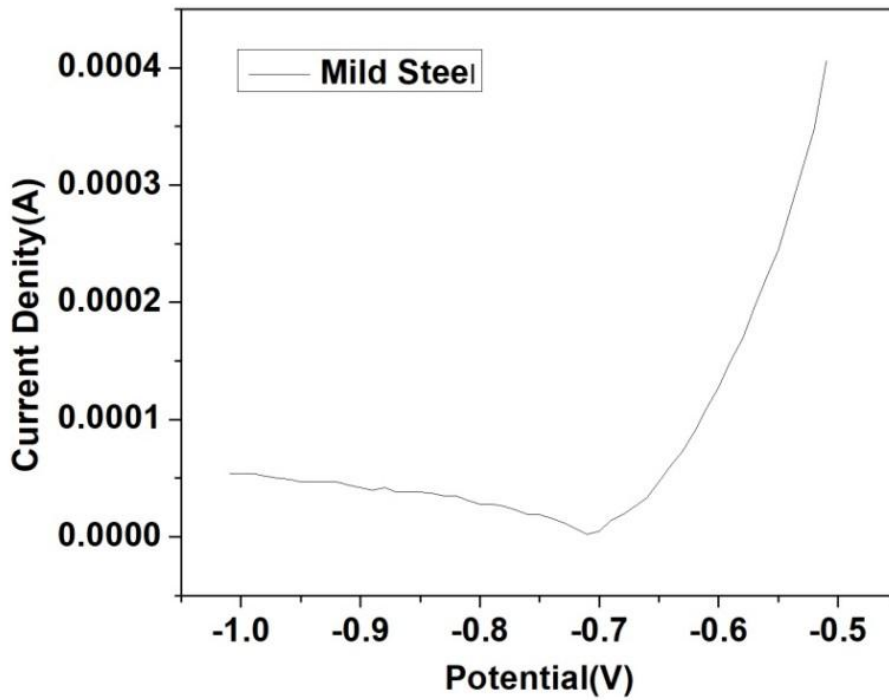

Fig. 5. Current-Potential curve for mild steel in 5 wt% NaCl Solution

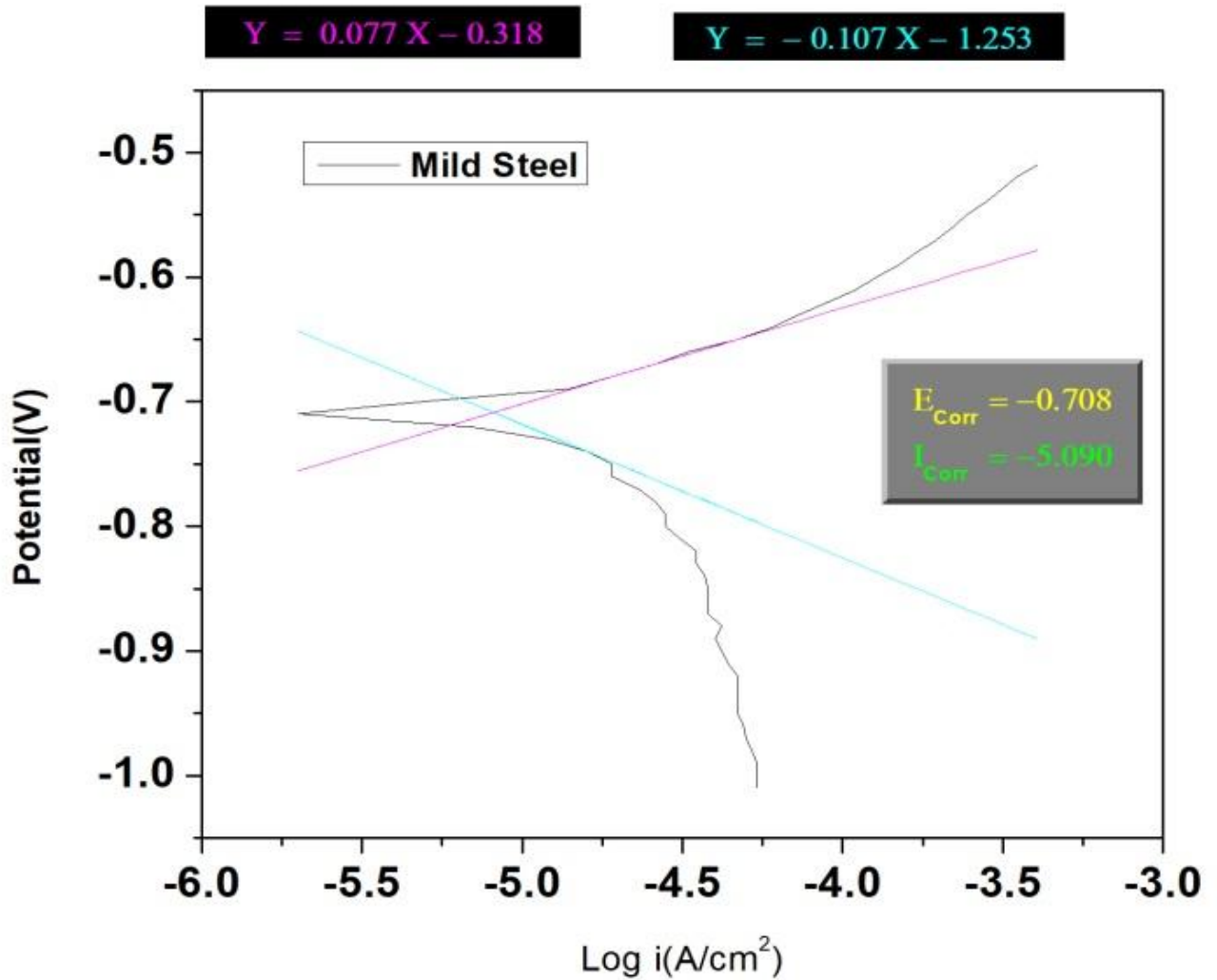

Fig. 6. Tafel plot for mild steel immersed in 5% NaCl Solution

4. CONCLUSION

The developed potentiostat was used to obtain polarization plots for mild steel. The obtained open circuit potential, E_{corr} , I_{corr} and corrosion rates were in close agreement with previous values reported in literature using commercially available potentiostats. Further research to improve the potentiostat performance would be necessary.

DISCLAIMER

“Abstract of this manuscript was previously presented and published in the following conference.

Conference name: ICAMAME 2022 : International Conference on Aerospace, Mechanical, Automotive and Materials Engineering

Dates: April 21-22, 2022

Location: Boston, United States

COMPETING INTERESTS:

Authors have declared that no competing interests exist. The products used for this research are commonly and predominantly use products in our area of research and country. There is absolutely no conflict of interest between the authors and producers of the products because we do not intend to use these products as an avenue for any litigation but for the advancement of knowledge. Also, the research was not funded by the producing company rather it was funded by personal efforts of the authors.

References

- [1] Wei-Song Wang, Wei-Ting Kuo, Hong-Yi Huang and Ching-Hsing Luo. Wide Dynamic Range CMOS Potentiostat for Amperometric Chemical Sensor. Vol.10, ISSN 1424-8220, 2010, pp. 1782-1797. doi:10.3390/s100301782.
- [2] Xian-man ZHANG, Zai-yu CHEN, Hong-Feng LUO, Teng ZHOU, Yu-liang ZHAO and Zi-cheng LING. Corrosion resistances of metallic materials in environments containing chloride ions : A Review. 2022, 32: 377-410.
- [3] H. H. Jassim and R.A. Hussain. Evaluation of the corrosion rate of different types of marine ship steels using Potentiostatic test method in Arabian Gulf sea water. Engineering and Technology Journal. 2017, 35(7): 609-716.
- [4] Boirs B. Chernov. Corrosion and metal protection in sea water. Asia Pacific Journal of marine science and education. 2011, 1(1): 81-87.
- [5] Feng-Juan WANG Jia. Development and Application of Virtual Potentiostat on Electrochemical Corrosion Measurement. 2012, 28(03): 615-622.
- [6] M. Scendo, J. Trela, Antoszewsk B and Kargul T. Corrosion resistance of the joint of stainless steels in aggressive Solution. Innovations in Corrosion and Materials. 2014, 4:118-126.
- [7] Gopinath, A. V., & Russell, D. An Inexpensive Field-Portable Programmable Potentiostat. 2006 4171(06): 23–28.
- [8] Rowe, A. A., Bonham, A. J., White, R. J., Zimmer, M. P., Yadgar, R. J., Hobza, T. M., Plaxco, K. W. Cheapstat: An open-source, “do-it-yourself” potentiostat for analytical and educational applications. PLoS ONE, 2011 6(9).
- [9] Dryden, M. D. M., & Wheeler, A. R. DStat: A versatile, open-source potentiostat for electroanalysis and integration. PLoS ONE, 2015, 10(10): 1–17.
- [10] Cordova-Huaman, A. V., Jauja-Ccana, V. R., & La Rosa-Toro, A. Low-cost smartphone-controlled potentiostat based on Arduino for teaching electrochemistry fundamentals and applications. Heliyon, 2021, 7(2). doi: 10.1016/j.heliyon.2021.e06259
- [11] Abdul Muid, Mitra Djamal, and Rahadi Wirawan. Development of a low cost potentiostat using ATXMEGA32. AIP Conference Proceedings 1589, 124 (2014); doi: 10.1063/1.486
- [12] Caffrey, C. M., Doyle, J., Ogurtsov, V. I., Twomey, K., & Arrigan, D. W. M. Development and Evaluation of an on-Chip Potentiostat for Biomedical Applications. International Conference on Biomedical Electronics and Devices. 2011, 103–107. <https://doi.org/10.5220/0002728601030107>

- [13] Dobbelaere, T., Vereecken, P. M., & Detavernier, C. A USB-controlled potentiostat/galvanostat for thin-film battery characterization. 2017, 2: 34–49. <https://doi.org/10.1016/j.ohx.2017.08.001>
- [14] Baranwal, A. R., Dudala, S., Rewatkar, P., Mohan, J. M., Salve, M., & Goel, S. Development of Completely Automated Poly Potential Portable Potentiostat. ECS Journal of Solid State Science and Technology. 2021, 10(2), 027001. <https://doi.org/10.1149/2162-8777/abdc15>.
- [15] Ainla, A., Mousavi, M. P. S., Tsaloglou, M. N., Redston, J., Bell, J. G., Fernández-Abedul, M.T., & Whitesides, G. M. (2018). Open-Source Potentiostat for Wireless Electrochemical Detection with Smartphones. 2018, 90(10): 6240–6246. <https://doi.org/10.1021/acs.analchem.8b00850>
- [16] Aremo, B., Adeoye, M. O., & Obioh, I. B. A Simplified Microcontroller Based Potentiostat for Low-Resource Applications. 2016, 37–46.
- [17] Oluwole O.O., Adegoke T.O., and Ajide O.O. Development of a field portable digital potentiostat. International journal of scientific & engineering. 2014, 5(4):654-660
- [18] Lisdat, F., and Schafer, D., Th use of electrochemical impedance spectroscopy for bio sensing, Anal Bional Chem. 2008, 391:1555-1567.
- [19] Beach RD, Conlan RW, Godwin MC, Moussy F. Towards a Miniature Implantable In Vivo Telemetry Monitoring System Dynamically Configurable as a Potentiostat or Galvanostat for Two- and ThreeElectrode Biosensors. IEEE Trans Instrum Meas. 2005 Feb; 54(1):61–72. doi: 10.1109/TIM.2004.839757.
- [20] Gabriel N. Meloni. Building a microcontroller based potentiostat: An in-expensive and versatile platform for teaching electrochemistry and instrumentation. Journal of chemical education. 2016, 93:1320-1322.