

Design and fabrication of a Speed Breaker Mechanism for power generation: A case study of Ikpoba Hill Benin City, Nigeria.

ABSTRACT

To meet the ever rising demand for power, innovative measures has to been put into place as convention power sources are fast depreciating. In light of the above, this study opines the distinctive design and fabrication of a small scale model speed breaker electric power generator by harnessing the kinetic energy from vehicles with goal of generating electric power. The model was developed utilizing available electrical and mechanical components such as flywheel (FW), battery, inverter, spring, rack and pinion, and DC motor. To this end, the aim of this paper is accomplished by demonstrating the process of conversion of kinetic energy to electrical energy using a movable speed breaker mechanism and show that it can produce adequate amount of power for streets lights and traffic lights. In light of the above, methodology employed to achieve the above includes the construction of a small scale model of the speed breaker generator; using adequate power calculations, design specification with proper review of related works. In conclusion, the proposed model was developed and constructed in such a way that little applied pressure manually (by hand) on the speed breaker caused generation of electrical power. The technical feasibility of this model is illustrated in real case scenario at Ikpoba hill in upper mission extension in Uteh community employed as a case study.

Keywords: Speed breaker generator, Energy conservation, flywheel, DC motor, power inverter

1. Introduction

The need for reliable and efficient extra supply to address extra load demands such as traffic lightings, street lighting etc. cannot be overemphasized [1]. Several emerging technology have been employed to address this need an evolving technology which is the solar street lightings to a greater extent supply the required energy however there is need for additional energy supply. In this context, this paper presents a technology that can be used to generate electricity from speed breaker in which the system employed is reliable and energy efficient and conservative. In light of the above, this offers a cost effective, alternative source of energy which can improve the economy as need for back up energy becomes greatly necessitated [2].

Recently, in Nigeria the need for street lighting in local areas to boost security as well address critical load demands in such zones has greatly been increased, as adverse effect of conventional sources has pushed the need to for alternative source with little or no pollution [3]. As population greatly increases, this has had an equivalent impact, depleting the conventional sources of power generation and consequently increased the need to strategize. This paper presents a model of conserving the kinetic energy from vehicle movement. Thus, the number of automobiles plying the roads and moving over speed breakers is increasing daily. According to the Road Transport Data released by National Bureau of Statistics (NBS) in 2017, Nigeria has an estimated vehicle population of over 11.5million cars nationwide [4-5], just visualise all those valuable power being unexploited.

To this end, beneath the speed breaker an electro-mechanical unit referred to as a energy hump, is employed in conserving this energy for power generation. The obtainable electrical output can be enhanced by assembling these energy humps in series connection mode [6] The produced energy can be stored by using different electrical storage devices such as batteries etc., thus prompting this study this could pave way for sufficient

and reliable supply required to serve immediate loads like street lights, traffic lightings and other lighter loads in our environment and thus leads in cost saving and improvement country's economy ,security and safety of the general public.[7].

Structuring of Model

The frame work of the machine is made of angle iron. This iron serves as the cradle for all the components and also acts as the pillar that holds up the upper part of the machine. The rack and pinion are vertically welded to the angle iron for firmness, a sheet metal of 2mm is bent like a C-shape facing downwards to form the bump which appears on the road for cars to move across. The barrel is made out of one inch steel pipe. It is lubricated with soft grease because it is one of the moving parts of the machine [8].

Benefits of the Model

- a) It can produce electric power in times of no wind or sunlight when windmill or solar cannot do so provided cars are plying the road.
- b) This generator can be used as a battery charger to charge external batteries when there are no other means of charging.
- c) In an undeveloped area or locality where there is no electricity yet but has a busy road, this machine can serve as a source of generating electricity in such places.
- d) Scrap parts can be used as new parts for this generator. It is made possible by recycling them and using them as new parts in the generator. For example, the steering rack of any car can be used to build this speed breaker generator, and the flywheel of an automatic transmission of a car can be used to multiply the rotation of the speed of the generator. The radiator fan dc motor can also be used to make the generator.
- e) It serves as a speed breaker thereby reducing road accidents.

Limitations of the Machine

- a) This machine is an underground machine this is prone to the possibility of flooding thus damaging the machine. To prevent this, it can be situated in sloppy area with good drainage system.
- b) The dc motor tends to have a very high opposing magnetic field because of this to press down the speed bump is very difficult and requires a lot of force at least 100Kg and thus an average man cannot generate electricity by stepping on it.
- c) It requires frequent attention.

2. Research Methodology

The research methodology employed in this study are outlined as follows;

- (a) Carried out comprehensive literature review
- (b) Proper design analysis and specifications
- (c) Study of the case study area for accurate meteorological data.
- (d) Fabrication of the proposed design model
- (e) Implementation of the design and test evaluation.

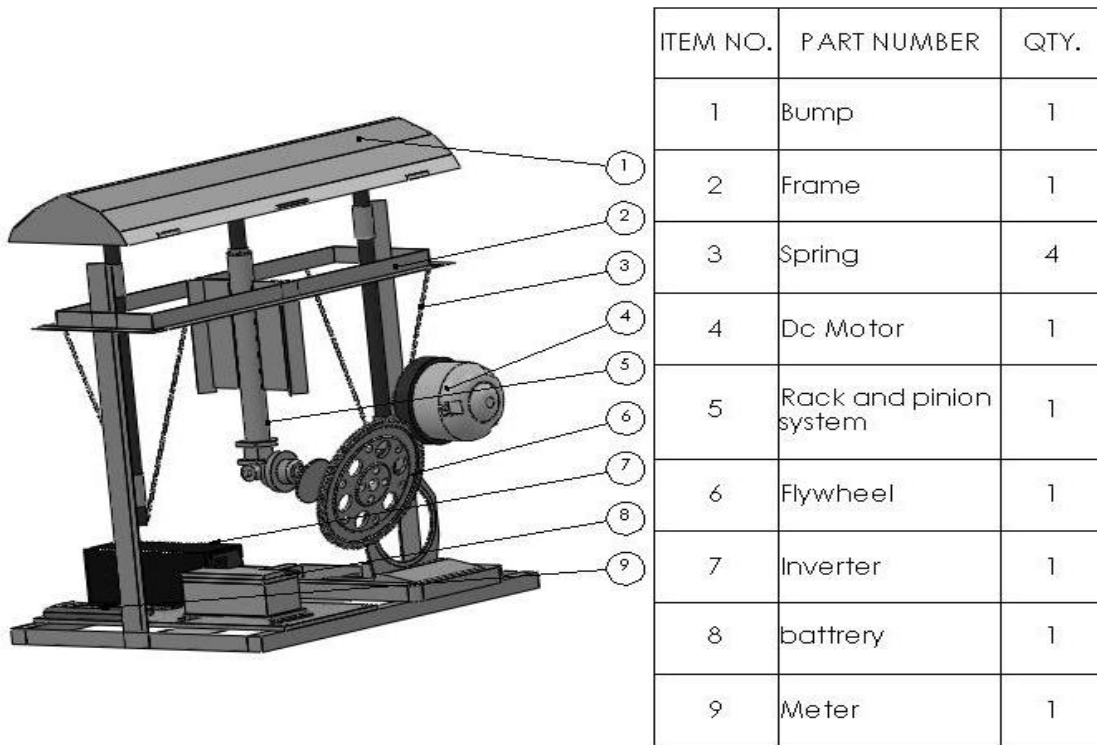

Figure.1 the Speed Breaker Generator

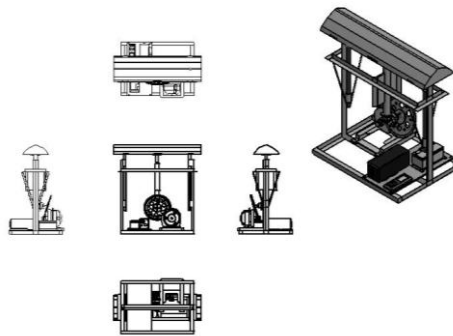

Figure .2 Front, Plan and Side View of Speed Breaker Generator

Block Diagram

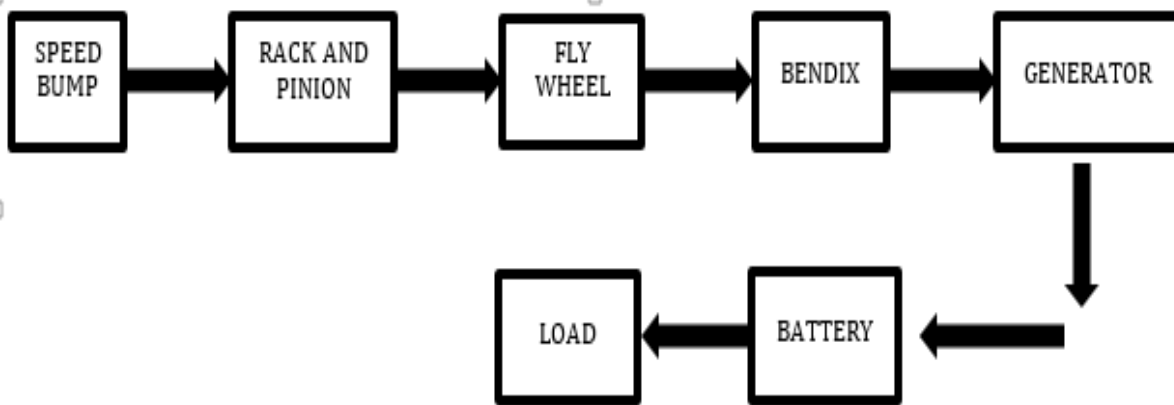

Figure.3 block schematics of the Speed Breaker Generator Model

Speed Bump

Regarding the deployment of this mechanism, part of it is buried while part is above ground. Comprised of bent sheet metal, the speed bump admits the applied energy and conveys it to the rack and pinion mechanism that is attached to it through arc welding joints[9].

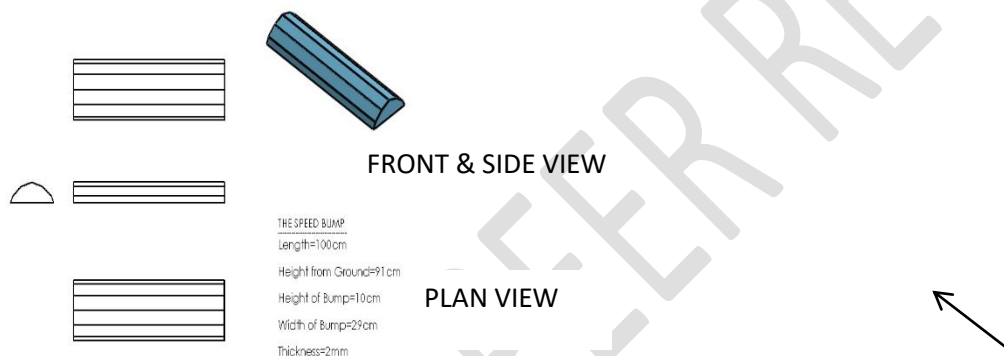

Figure.4 Front, Side and Plan View of the Speed Bump

Specifications of speed bump

Table.1 below gives exact values of unit employed for the speed bump;

Table 1. Speed bump specifications

Length of bump	100cm
Height of bump	10cm
Height from ground	91cm
Width of bump	29cm
Radius of bump	38cm
Vertical distance travelled by bump	12cm
Vertical distance travelled by bump	2mm

Rack and Pinion Mechanism

This mechanism that receives the vertical motion of the speed bump and converts it to the required rotational motion. It is installed in a vertical position which enables us to convert the vertical movement of the speed bump to rotational movement or force. It is made of vanadium to increase to wear and tear and overheating [10].

Specifications of Rack And Pinion

Length of mechanism [ILOM] = 61cm

Radius of mechanism [ROM] = 3.5cm

Flywheel

Conventionally speed multiplier. It helps to multiply the speed of the pinion and rack mechanism by a certain factor called "SPEED RATIO" to a greater speed needed to drive the generator.

Specifications of Flywheel

Material = vanadium

Number of teeth[NOT] = 120

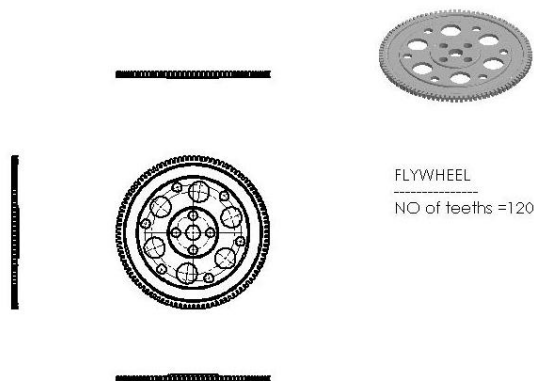

Figure.5 Front, Side and Plan view of Flywheel

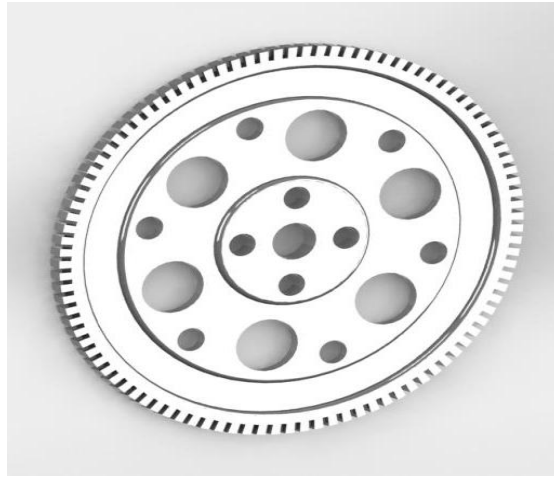

Figure 6. Model Flywheel

Bendix Drive

Employed in electrical mechanism, the Bendix drive functions as an interface between the pinion mechanism and the rotor of the machine. It transmits the improved rotational speed from the flywheel to the rotor of the generator [11].

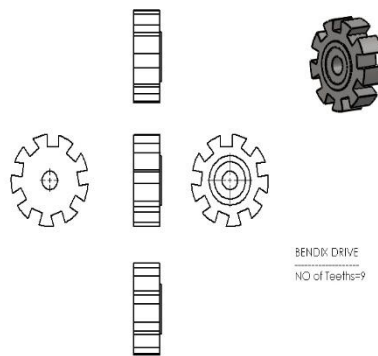

Figure.7 The Front, Side and Plan view of Bendix Teeth

Specifications of Bendix Drive

Number of teeth[NOT] = 9

Made of vanadium

Speed Ratio

$$SPEED\ RATIO = \frac{NO\ OF\ LARGER\ WHEEL\ TEETH\ (FLYWHEEL)}{NO\ OF\ SMALLER\ WHEEL\ TEETH(BENDIX)}$$

$$SPEED\ RATIO = \frac{120}{9} = 13.3333$$

Therefore, the speed ratio of the machine is 13.333. This denotes that the speed of the generator will be about thirteen (13) times that of the speed created by the applied force [10] .

Returning spring

This helps to return the speed breaker back up when the applied force is removed. It is attached to the barrels that are attached to the speed bump.

Specifications of Returning Spring

Number of springs = 4

Resistance of spring = low

DC Generator

It converts the rotational motion produced to electrical energy. The generator's rotor receives the rotational motion from the Bendix causing it to rotate in a magnetic field to generate electricity.



Figure .8pictorial diagram of a Dc Generator

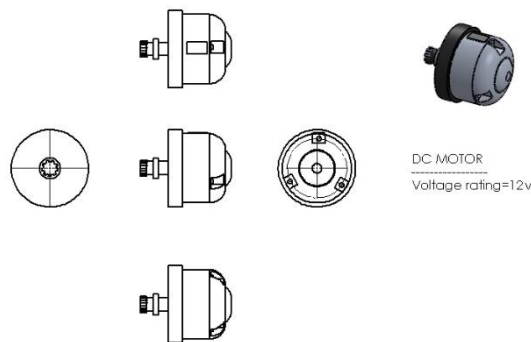

Figure.9 The Front, Side and Plan View of the Generator

Specifications of DC Generator

Voltage rating = 12V

Frequency = 50Hz

Maximum speed = 3000rpm

Battery

In the context of this model, a 12V battery is employed for energy storage;

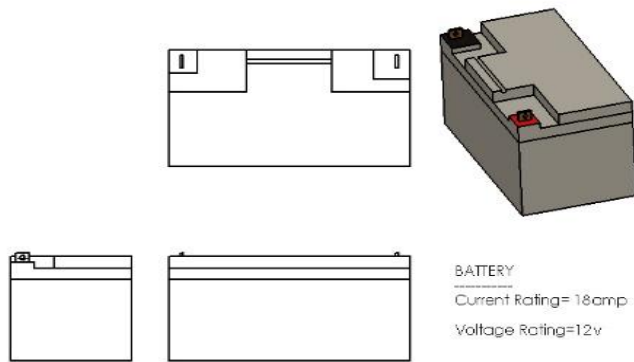

Figure. 10 Front, Side and Plan View of the 12v Battery

Specifications of Battery

Current rating =18AH

Voltage rating = 12V

Inverter

An inverter is employed in this model to convert the stored dc voltage from the battery into a suitable ac form that can be used by the lighting points.

Specifications of Inverter

Rating = 500W

Wave = Sine wave

Structuring

The support structure of the machine is made from angle iron which is used to form the pillar and base holding up various components. There is also a barrel attached to the speed bump and springs to take the speed bump back up immediately the applied force is removed.

Dimensions of Structure



Figure.11 the Support Structure of the Model

Size of angle iron = 4cm

Length of vertical iron = 91cm

Number of vertical iron = 4

Size of barrel = 3.81cm

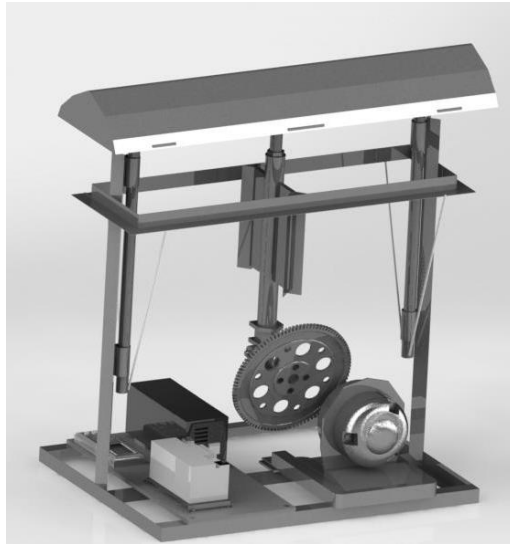

Figure.12 Front View of the Model

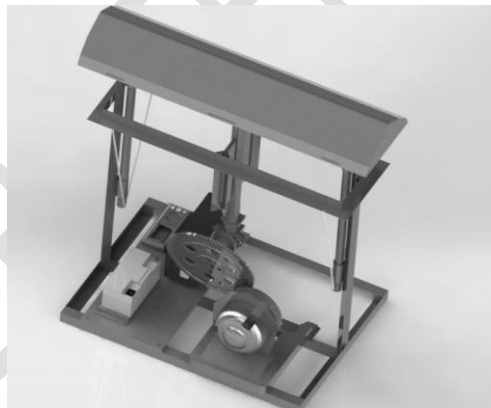

Figure.13 Plan View of the Model

3. Energy Calculation one

Considering a mass = 94Kg	The distance of travel of speed breaker = 10cm	Work done = weight of body x distance travelled by the speed bump
Weight of body = $94 \times 9.81 = 922.14\text{N}$	Therefore, Work done = $922.14 \times 0.1 = 92.214\text{J}$	Assuming this is the power generated per second, then,
Power generated in one minute = $92.214/60 = 1.53\text{W}$	Power generated in one hour = $60 \times 1.53\text{W} = 92.214\text{W}$	Power generated for 24 hours = $24 \times 92.214 = 2.2\text{KW}$

Area of research Study

A detailed survey was carried out at the case studied environment. The best possible location is impacted by some topological factors of the road in the designated area and the efficiency of the drainage system, the absence of street lights and speed breakers on the road to achieve the desired results.

Ikpoba hill in upper mission extension in Uteh community of Edo state, was chosen as a suitable location because it fits all the aforementioned criteria. An average distance of 1.4km was covered starting from the end of the Ikpoba river bridge passing along Tenboga junction, all the way to Erediawa junction.

Estimations based on the distance covered (1.4km) an average of 65 lighting points would be required.

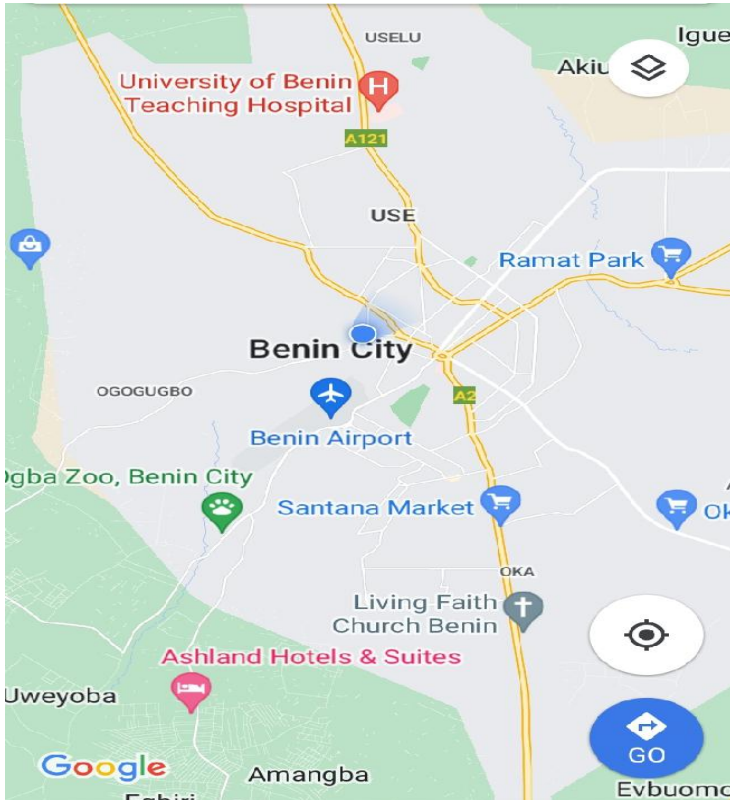

Figure .14 Google map location of uteh community

Energy Calculation two

Supposing:

A 12.5 KVA inverter will be used. The mass of the average vehicle travelling over the speed breaker = 300kg

Height of speed breaker = 10cm (1)

Then,

Work done = weight of the body x distance travelled by the vehicle

Weight of body = 300kg x 9.81 = 2943N (2)

Distance travelled by the body = height of speed breaker = 10cm

Estimation of output power for number of passing vehicles

Power = work done/second = (2943 x 0.1)/60 = 4.905W (3)

The output power developed for 1 vehicle passing over the speed breaker for one minute = 4.905W

Assuming 30 vehicles passes over the speed breaker for one minute, then power generated = $30 \times 4.905 = 147.15W$ (4)

Therefore power generated for one hour with 30 cars per minute = $147.25 \times 60 = 8.829KW$

Power developed from 7am – 7pm (12 hours) = 105.9KW

Assuming power factor = 0.85

The total power developed = $105.9KW / 0.85 = 124.644KVA$ (5)

Estimation of batteries employed by using reactive power

Voltage = 240V

Recall, $Q = AV$ (6)

$A = Q/V = 124.644KVA / 240V = 519.35A$

Capacity of battery, $C = A \times \text{Hours}$, Hours = 12hrs

$C = 519.35 \times 12 = 6232AH$ (7)

Number of batteries needed = $6232 / 200 = 31$ batteries

Estimated number of street lights to be installed on the road = 65 street lights (150w each)

Therefore, the total power consumption = $65 \times 150 = 9750 = 9.75KW$ (8)

Apparent power conversion,

Power = $9.750KW / 0.85 = 11.471KVA$ (9)

The energy produced is capable of sufficient supply to the load and can be improved on in future studies.

4. Results and Discussion

Numerous test was carried out on the designed speed breaker model and results obtained are highlighted below;

Test performed;

1. Output voltage with load battery
2. Output voltage without load (battery)

Result

Output with Load

Voltage = 3.23V



Figure .15 Multimeter voltage output with load (battery)

Output without load (Battery)

Voltage = 4.46V



Figure. 16 Multimeter voltage output without Load (Battery)

The realized output voltages with and without the load denotes the success of this study, albeit some slight limitations, of which the value of voltage produced was lower than expected but with certain adjustments and implementations of minor alterations a better output can be obtained, thus indicating that this study is subject to more research.

Outcomes of the study

- The realised generator output voltage is higher with inclusion of the battery rather than when it is not linked to the system as stated above .
- The peak voltage realised after numerous run-test gave an output of 5 volts, nonetheless, a 12 volts battery was utilized as it is also compactible.

Merits of Energy Generation System employing Speed Breaker

- Reduced adverse pollution owing to conventional/fossil fuel energy sources.
- Modest structure, improved technology, and low cost of maintenance.
- Need for manual work lessened.
- There is zero need for fuel.

5. Reliance on fossil is drastically reduced.

5. Conclusions

This study opined the design of a speed breaker mechanism for power generation. The paper presented a model, experimental setup, analysis, design and challenges of the proposed mechanism. In addition, the viable immediate load applications are outlined, and an up to date review of key findings and limitations of this study on existing research, with research trends in speed breaker mechanism are also presented. Further, the research relevance and improvements on traditional speed breaker systems are highlighted and further success in the performance evaluation with variation in load are also outlined as follows:

1. Assuming the weight of the body moving over the speed breaker is not varied. Voltage created is dependent on speed deviation at which velocity bump was pushed downward. If the bump is pressed down gently, pressure applied to the speed breaker over a distance period has an inverse proportionality with the speed and voltage realised.
2. Assuming the speed at which the speed bump is pushed by different types of cars is kept constant, it becomes that the voltage produced varies with the vehicles load on the speed breaker. Assuming least load capacity was applied and with an extremely low force resulting in low voltage production. Consequently the load increment has a direct proportionality with voltage realized. Furthermore, study was successful albeit some slight limitations one of which was the value of voltage produced was lower than expected but with the implementation of minor rectifications a suitable voltage can be obtained, hence this study is subjected to future research.

Recommendations

The following recommendations for the speed breaker power generator mechanism are given

1. A charge control circuitry should be installed in future works to ensure proper charging of the batteries to elongate its life span.
2. An Automatic Switching system should be installed.
3. More than one rack and pinion connected to generators can be incorporated under the same speed bump so as the increase the general electrical output produced by one passing vehicle.
4. A casing can be incorporated to serve as protection for the internal components of the machine.

COMPETING INTERESTS DISCLAIMER:

Authors have declared that no competing interests exist. The products used for this research are commonly and predominantly use products in our area of research and country. There is absolutely no conflict of interest between the authors and producers of the products because we do not intend to use these products as an avenue for any litigation but for the advancement of knowledge. Also, the research was not funded by the producing company rather it was funded by personal efforts of the authors.

Abbreviations

DC- direct current;

AC- alternating current;

FW-flywheel

LOM- Length of mechanism

ROM-radius of mechanism

NOT-Number of teeth

References

- [1] Selvaraj, R.S., Sivamadhavi, V. (2010), Magnitude of Green House Effect and the contribution of Carbon di oxide, *Recent Advances in Space Technology Services and Climate Change* (RSTSCC), vol,13-15 , pp. 41 – 44, Chennai.
- [2] Shakun Srivastava, Ankit asthana, , “produce electricity by the use of speed breakers, *Journal of Engineerin g Research and Studies*”, Vol.2, pp.1 2011.
- [3] Mukherje, D., Chakrabarti, S, (2005), Non-conventional power plants, New Delhi
Sharma.P.C, (2003), Principles of renewable energy systems, *Public printing service*, New Delhi.
- [4] Watts. (2004), Effects of speed distribution on the Harmonies model predictions, *Inter-noise Conference*, Prague.
- [5] Aswathaman.V and Priyadharshini.M, (2011), Every Speed Breaker Is Now A Source Of Power, *International Conference on Biology, Environment and Chemistry*, IPCBEE vol.1 IACSIT Press, Singapore.
- [6] Parul Bisht and Rajni Rawat, (2013), Electricity Generation through Road Ribs using law of Electromagnetic Induction, *Conference on Advances in Communication and Control Systems*, (CAC2S 2013).
- [7] N. N. Ghuge, Arati Sathe, Varsha Patil, Anagha Warankar, (2014), Every Speed Breaker Is A Source of Power, *International. Journal of Engineering Research and Applications*, ISSN: 2248-9622, Vol. 4, Issue 3(Version 6), pp.01-05
- [8] Alok Kumar Singh , Deepak Singh, Madhawendra Kumar,Vijay Pandit and Prof.SurendraAgrawal, (2013), Generation of Electricity through Speed Breaker Mechanism, *International Journal of Innovations in Engineering and Technology* (IJIET), Volume-2, Issue-2, ISSN:2319-1058.
- [9] A.kaurl,”power Generation using speed breakers with auto street light. *International journal of Engineering science and innovative Technology* (IJESIT), 2013.
- [10] A Gupta, *international journal of Electrical and Electronics Research* , Electricity Generation from speed breakers ,march 2016.
- [11] D Rao, Design and fabrication of power generation system using speed breakers. *International journal of current engineering and technology*, August 2014.
- [12] Mukherjee Chakrabarti,s. non-conventional power plants (public printing service ,new delhi,2005).
- [13] Miller R, power system operation , (McGraw,Hill New York ,1970).
- [14] B.santosh sharma, V.Jyothi, D.Sudhir, Design of power generation unit using roller mechanism(ISOR-JEEE may-june 2104)
- [15] Venkatesh Babu,J.Manikandan, “design and fabrication of power generation mechanism from speed breaker roller mechanism”, *International journal of pure and applied mathematics*, Vol.116, pp.301-306,2017.
- [16] Srinivasan V., Optimizing air traffic conflict and congestion using genetic algorithm, *Middle – East Journal of Scientific Research*, v-20, i-4, pp-456-461, 2014.
- [17] Palanivendham,M; Logeshwaran, S, Naresh, G ; Ankush , K ; Sidhaant , A; Shivam, S, Design and fabrication of speed bump for energy generation,IOP conference series,Materials science and Engineering, Vol. 993,issue 1,pp.012149 2020.speed Bump power generator,
- [18] Iyen C,Anylin P, Umar I,Jaafaru,S,wansah,J.f,Isehtruction,A,Akeredolu,b,Design and Construction of a Speed bump power generator,*International journal of innovative research and in Electronics and communication*, <https://dx.doi.org/10.204231/2349.4050.0402001>

[19] Joselin, Hebert, G.M,Iniyan, S, Sreevlasan,E,Rajapandian,S, A review of wind energy technology,Reneable sustainable Energy Review,vol.11, pp.1117-1145,2007.

UNDER PEER REVIEW