

# Original Research Article

## Paper for Screen Printing Applications – A Paper Development Study

---

### ABSTRACT

Screen printing originated in China during the Song dynasty (960-1279 CE) and is used today in commercial and artistic applications. The presented research project describes the development of a screen-printing product for studio art applications.

The improvement of the paper properties from laboratory and small 12-inch laboratory paper machine art paper development, followed by a semi commercial production at a speed of 128 ft/min on a 48-inch semi commercial paper machine for the final art paper, showed an improvement throughout the development process for mechanical and optical paper properties. The finished art paper product exceeded the expectations by the artist using the art paper in the studio.

The produced art paper with a basis weight of 63 g/m<sup>2</sup> and a thickness of 94 μm is produced from a mixture of 70% northern bleached hardwood Kraft pulp and 30% northern bleached softwood Kraft pulp.

The ISO brightness and opacity of the art paper bluish gray colour was at 35.6% and 100%, The ISO color value was for the L\*, a\*, b\* Hunter color scale 65.8%, 0.9, and 1-0.7 respectively.

As a parameter for attachment of water-based inks, surface roughness was for the top side 1703 ml/min and bottom side (wire side) 1336 ml/min. The Cobb number indicating water penetration of the art paper is 28.9 g/m<sup>2</sup>.

Bending stiffness in machine direction and cross machine direction resulted in 22 mN and 12 mN respectively. The tensile index was measured at 52.9 N·m/g for the machine direction and 31.6 N·m/g for de cross-machine direction.

*Keywords: Art paper, papermaking, paper machine, screen printing*

### 1. INTRODUCTION

Paper has come a long way since it was invented in ancient China during the Eastern Han dynasty (105 CE) by Cai Lun [1]. The Art of Papermaking was kept as a secret, and it ended up eventually in Japan 500 years later. It took over one millennium, since its invention, till it reached the European continent and another 500 years to spread all over Europe and to Mexico, the US and Canada [2].

Paper products as we know them today are produced from extracted cellulose fibers from hardwood (leave) and softwood (needle) trees and or recycled paper fiber material, which can contain a mixture of hardwood or softwood cellulosic fibers materials. Other materials such as filler materials, color pigments and other chemical additives might be added based on the specific product requirements [3,4].

The machines paper is produced on, can be over 600 m long, and are marvels of technology. Each machine is designed to the individual paper product requirements. Paper

machines today can operate at speeds of over 2000 m/min producing a paper sheet with a width of over 11.5 m at daily production rate of over 4,500 tons [5,6].

Paper sheet can be described generally as an orthotropic thin plate with a thickness ranging from 40  $\mu\text{m}$  to over 500  $\mu\text{m}$  and a basis weight from under 15  $\text{g}/\text{m}^2$  to over 500  $\text{g}/\text{m}^2$  depending on the paper product and its application as a writing or printing material, packaging (board) material or, tissue product.

Each paper grade has its own unique requirements in regard to mechanical integrity, surface topography, optical appearance and printability based on its use and printing process applied.

The following manuscript describes the development of a specialized paper for artistic screen printing applications using water based inks. Screen printing originated in China during the Song dynasty (960-1279 CE) and further developed in other Asian countries together with wood block printing techniques [7]. The screen printing process as we use it today uses a mesh like material on which a negative image of the picture is created by blocking off the permeable area of the screen. The actual image is created by allowing the ink to penetrate through the permeable area (screen) screen onto the print media.

## 2. MATERIALS AND METHODS

The following materials and methods were used for the Art Paper for screen printing applications.

### 2.1. Materials Used

For the development of the SPA paper Northern Bleached Maple Hardwood Kraft (NBHK) pulp, Bleached Eucalyptus Kraft (BEK), and Northern Bleached Softwood Kraft (NBSK) were selected as fiber material.

Alkyl Ketene Dimer (AKD) was used increase hydrophobicity and to improve printing properties [8] and cationic starch was added to improve strength properties of the paper product.

Ground Calcium Carbonate (GCC) with a particle size of 1.4  $\mu\text{m}$  was used in dry powder form as possible filler material to increase optical properties to save of fiber materials [3].

Dyes used for the art grade were an anionic blue dye, cationic red, and yellow and black dye from the Kemira Lavacell™ family.

Retention aid used for the art grade was a cationic acrylamide copolymer (cPAM) from Kemira FennoPol™ polyacrylamide flocculant family.

### 2.2. Testing Methods

For this research project the following testing methods of the Technical Association of the Pulp and Paper Industry (TAPPI) and International Organization for Standardization (ISO) were used:

Beating of pulp (Valley beater method) in accordance with T 200 sp-06 “Laboratory beating of pulp (Valley beater method)” [9].

Handsheets were prepared according to TAPPI T 205 sp-12, “Forming handsheets for physical tests of pulp” [10]. Physical testing of handsheets was performed in accordance with T 220 sp-06, “Physical testing of pulp handsheets” [11]. Freeness of pulp was measured as Canadian Standard Freeness (CSF) according to T 227 om-09 “Freeness of pulp (Canadian standard method)” [12]. Consistency of the pulp suspensions was measured with TAPPI T 240 om-07 “Consistency (concentration) of pulp suspensions” [13].

Conditioning of the paper samples was done according to T 402 sp-08, “Standard conditioning and testing atmospheres for paper, board, pulp handsheets, and related products” [14]. Basis weight was measured with T 410 om-08. “Grammage of Paper and

Paperboard (weight per unit area)" [15]. Thickness of the paper was measured with TAPPI T 411 om-10. Thickness (caliper) of paper, paperboard, and combined board [16]. Moisture content of pulp was determined by T412 om-06 "Moisture in pulp, paper and paperboard" [17]. Water absorbency was measured using TAPPI method T 441 om-04 Water absorptiveness of sized (non-bibulous) paper, paperboard, and corrugated fiberboard (Cobb test) [18]. Bending resistance was measured according to TAPPI method T 489 om-08 "Bending resistance (stiffness) of paper and paperboard (Taber-type tester in basic configuration) [19]. Tensile strength was evaluated using TAPPI method T 494 om-06 Tensile properties of paper and paperboard (using constant rate of elongation apparatus) [20]. Surface roughness of the paper product was measured with TAPPI method T 538 om-08. Roughness of Paper and Paperboard (Sheffield method) [21]. Brightness was measured according to ISO 2470 "Paper, board and pulps - Measurement of diffuse blue reflectance factor – Part 1: Indoor daylight conditions (ISO Brightness) [22]. Opacity was determined according to ISO 2471:2008 Paper and Board: Determination of Opacity (Paper Backing) – Diffuse Reflectance Method [23]. Whiteness/Color was measured according to ISO 11476:2016 Paper and Board – determination of CIE Whiteness, C/2° (Indoor Illumination Conditions) [24].

### 2.3. Art Paper Handsheet Development Procedure

The handsheet development was done in a four-step process according to pulp fibers needed and time requirement for making the handsheets. First, a visual and preliminary fiber evaluation of handsheets was done according to TAPPI method T 200-sp-06 were made. The produced TAPPI handsheetes have a diameter of approximately 6.25 in (159 mm). This step included a beating evaluation according to TAPPI method T200-sp06 of the selected pulp compositions to provide better interfiber bonding during sheet forming. For a detailed printing evaluation, handsheet making was switched in the second development process to a 12 inch (300 mm) square handsheet former shown in Fig. 1. The prepared fiber suspension was stored in the pulp storage tank and moved from the pulp storage to the handsheet former as needed. A paper machine wire fabric was used as the supporting forming wire. The produced wet handsheet was then couched on a dryer fabric and then dried together with the dryer fabric a drying device as shown in Fig.1.

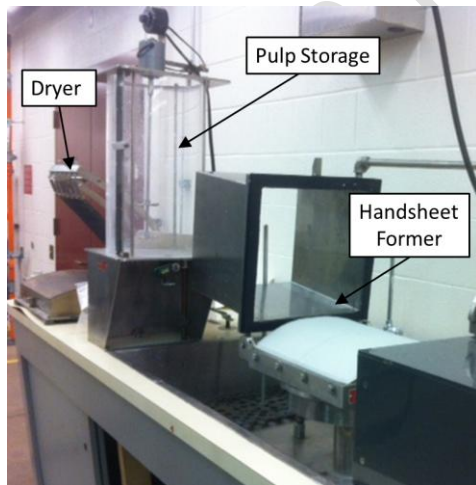

Fig. 1. 12" (300 mm ) Handsheet forming [25].

In the third development process, the produced 12-inch square handsheets were then tested by artists for screen printing suitability producing prints as shown in Fig. 2.



**Fig. 2. Screen printed test images [26].**

The fourth development step included a beating evaluation according to TAPPI method T200-sp06 of the final selected pulp composition to provide better interfiber bonding during sheet forming.

After the final handsheet composition and the pulp fiber beating level was selected by repeating development process 1 to 3, handsheets were made in a fourth step using a MK Systems Inc. sheet former, shown in Fig. 3. for the final visual and print evaluation by the artist. The MK Systems Inc. sheet former allows to make a more precise 12-inch (300 mm) square handsheets, close to a quality level as a 12-inch (304 mm) pilot paper machine, but without applying the process steps of fiber orientation during sheet forming at the fourdrinier section, pressing, drying and clandering section.



**Fig. 3. MK Systems Inc. dynamic sheet former [25]**

#### **2.4. Laboratory Fourdrinier Paper Machine Run**

For upscaling the laboratory tested art paper into continuous production scale, a 12-inch (304 mm) wide Laboratory Fourdrinier Paper Machine (LFPM) located at the pilot plant of the Chemical Engineering Department at SUNY-ESF is used to produce a continuous art paper that can be cut into smaller sizes for print evaluation as described in Section 2.4. The set-up of the LFPM system can be described as follow:

#### **2.4.1. Stock Preparation System**

The stock preparation of the LFPM, shown in Fig. 4., consists of a 5 hp (3.73 kW), 35 gal (132.5 l) low consistency pulper, a 3 hp (2.24 kW) transfer pump, a 10 hp (7.46 kW) low consistency conical Jordan refiner, and two storage chests with a usable volume of 240 gal. (908.5 l) each, and a propeller agitator with 1.5 hp (1.12 kW). The chests can be operated separately or together. Additives for papermaking can be added either in the pulper or the storage chests.

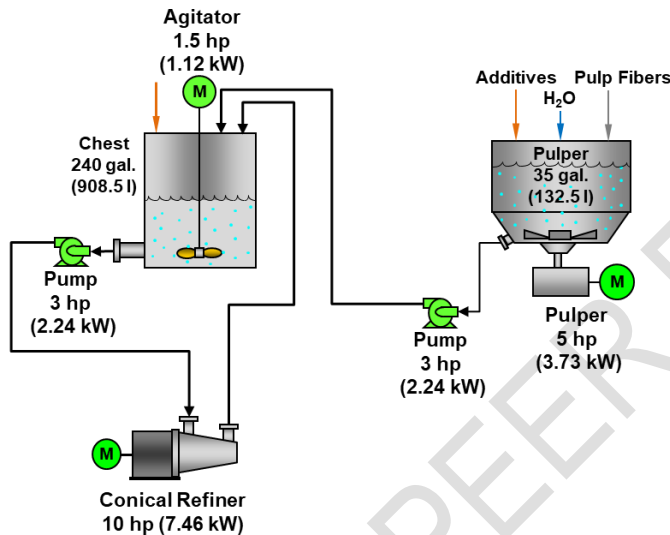

**Fig. 4. Laboratory stock preparation system [25].**

#### **2.4.2. Wet End System**

The wet end of the LFPM, shown in Fig. 5., consists of the two storage chests with a usable volume of 240 gal. (908.5 l) each, and a propeller agitator with 1.5 hp (1.12 kW). The 2 storage chests serve as the LFPM machine chest. Additives might be added at the machine chest as needed. The chests can be operated separately or together. An impeller transfer pump with 1.5 hp (1.12 kW) supplies the prepared fiber suspension to the stuff box. Additives might be added at the stuff box as needed. From the stuff box the fiber suspension is metered into the 10 gal. (37.4 l) mix chest, where additives might be added as needed. Part of the fiber suspension from the stuff box is recirculated to the machine chest. In the mix chest the fiber suspension is diluted with the white water from the LFPM white water trough. A possible overflow is transferred to the sewer. An impeller pump with 1 hp (0.75 kW) transfers the final prepared fiber suspension to the LFPM for papermaking.

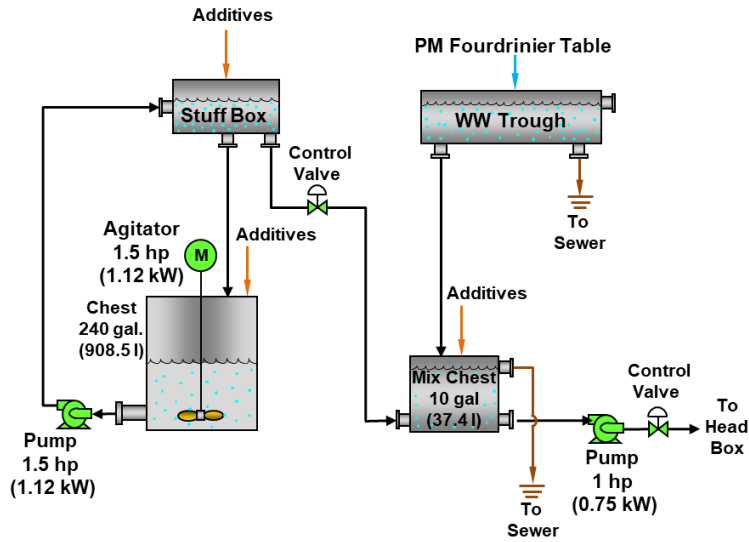

Fig. 5. Wet End of the 12" laboratory Fourdrinier paper machine [25].

### 2.4.3 12" Laboratory Fourdrinier Paper Machine

The LFPM shown in Fig. 6. was used to upscale the produced art paper from the handsheet study.

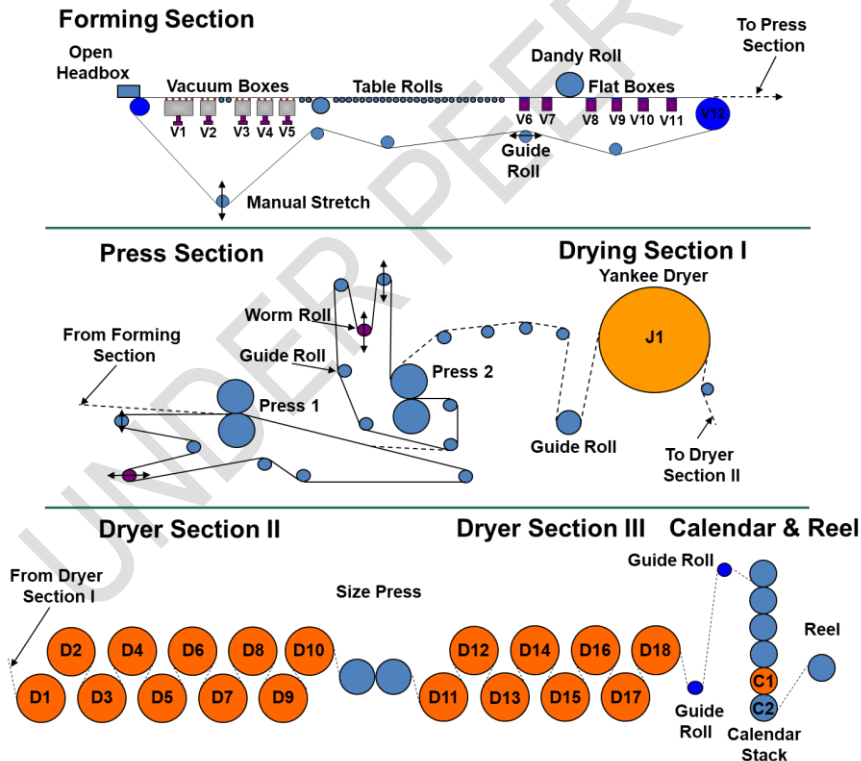

Fig. 6. Laboratory Fourdrinier paper machine [25].

The LFPM features a 70 inch (1778 mm) long Fourdrinier section followed by a 2-nip press section. After the press section, there is a dryer section with a Yankee dryer (J1), followed by

a 1<sup>st</sup> and 2<sup>nd</sup> dryer section with 10 (D1-D10) and 8 (D12-D18) electric heated dryer drums. Each dryer drum can be heated to up to 343°C (650°F). Between the 1<sup>st</sup> and 2<sup>nd</sup> dryer section a size press is located. A 6-roll vertical calendar stack, of which on roll (C2) can be heated is located after the dryer section followed by the reel. The LFPM wet end has an total installed electrical power of 4 hp (3.0 kW) and the LFPM has a total installed power of 30 hp (22.5 kW). The LFPM can produce a finished paper product with a basis weight between 20 g/m<sup>2</sup> and 750 g/m<sup>2</sup> at a speed of up to 8.0 m/min.

## 2.5. 48-inch Small Commercial Fourdrinier Paper Machine

To produce the final art paper on a large scale, a 48-inch Small Commercial Fourdrinier Paper Machine (SCFPM) located at the pilot plant of the Chemical Engineering Department at SUNY-ESF is used to produce a 48-inch (1219.2 mm) wide continuous paper sheet that can be cut into all standard paper sizes. The results from the art paper runs at the LFPM are used to upscale the art paper product for commercial production of 700 lbs. of art paper. The set up of the commercial SCFPM run can be described as follows:

### 2.5.1. 48-Inch Small Commercial Fourdrinier Paper Machine Stock Preparation

The stock preparation of the SCFPM, shown in Fig. 7., consists of a 50 hp (37.28 kW), 1800 gal (6800 l) low consistency pulper, a 15 hp (11.12 kW) low consistency conical Jones-Bertram beater, and a storage chests with a usable volume of 15000 gal. (56780 l). the storage chest is agitated with a propeller 20 hp (14.91 kW) propeller agitator. Additives for papermaking can be added either in the pulper, the Jones-Bertram beater or the storage chests.

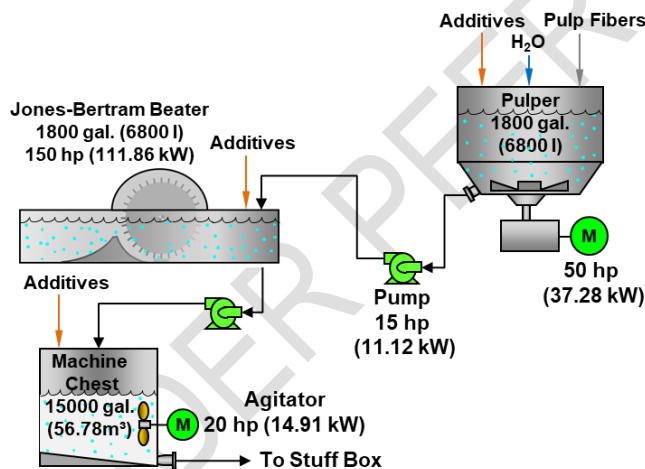

Fig. 7. 48-inch small commercial Fourdrinier paper machine stock preparation [25].

### 2.5.2. 48-Inch Small Commercial Fourdrinier Pilot Paper Machine Wet End System

The wet end of the SCFPM, as shown in Fig. 8., consists of a 6500 gal. (56.78 m<sup>3</sup>) machine chest with a 20hp (14.91 kW) agitation propeller. A 15 hp 11.12 kW) impeller pump transfers the stock to a Stuff box. A basis weight mixing valve regulates the pulp fiber flow to a 184 gal (743.3) mixing chest, where the pulp fibers are mixed and diluted with the white water from the paper machine, head box overflow, additives and pressure screen reject flow to a head box consistency of approximately 1%. The white water used for dilution consists of removed water from the table rolls, low vacuum and high vacuum which is pumped from the seal pit to with a 3 hp (2.25k kW) impeller pump to the white-water trough. From the mixing chest, the pulp fiber suspension is pumped with an impeller head box pump having 15 hp (11.12 kW) to a pressure screen driven by a 30 hp (22.37 kW) electro motor. The head box screen supplies the paper

machine headbox with the prepared pulp fiber suspension. The volumetric flow to the head box is controlled by a flow control valve. The pressure screen reject is sent back to the mixing chest.

The SCFPM vacuum system consists of 2 vacuum pumps with 40 hp (29.82 kW) and 20 hp (14.91 kW), having a common header. The vacuum systems provide vacuum for the FCFPM high vacuum boxes, the couch roll and the press section vacuum boxes.

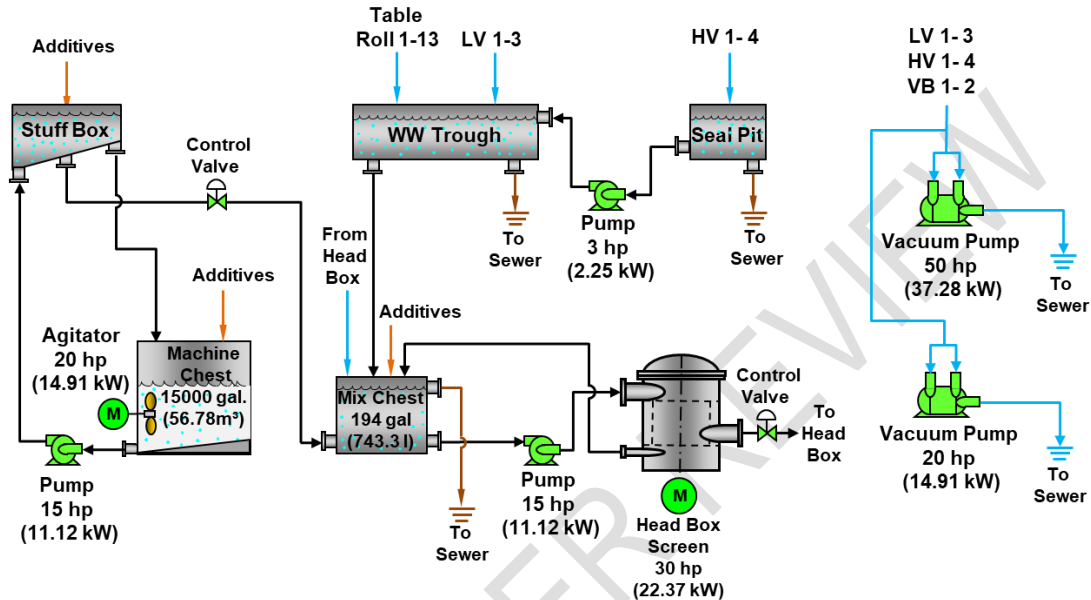

Fig. 8. 48-inch small commercial Fourdrinier paper machine wet end system [25].

### 2.5.3. 48-Inch Small Commercial Fourdrinier Paper Machine

The SCFPM shown in Fig. 9. has a 280" (7112.0 mm) long Fourdrinier Forming Section (FFS) with a 48" (1219 mm) headbox slice opening and forming board. The Breast roll of the FFS is attached to a shake having 3 hp (2.23 kW) and a stroke of 0 to 7/8-inch (0 to 22.23 mm) adjustable to a frequency between 2.5 to 10 Hz for improving sheet formation and fiber orientation on the forming wire. In addition, the FFS contains 13 table rolls with a diameter of 3.5" (88.9 mm), 3 foil boxes, 4 high vacuum sections, a 12" (304.8 mm) dandy roll, and a 14" (355.6 mm) diameter vacuum couch roll, including a couch pulper with a 1 hp (0.75kW) electro motor. The couch roll is driven by a 20 hp (14.91 kW) electro motor.

The paper is transferred from the FSS to the press section which contains a 1<sup>st</sup> and a 2<sup>nd</sup> press with a maximum loading of 500 pli (87.6 kN per m) press loading. The 1<sup>st</sup> press has a press roll with 13" (330.2 mm) diameter and a 14" (355.6 mm) grooved roll. The 2<sup>nd</sup> press has a press roll with 14" (355.6 mm) diameter and a 14" (355.6 mm) smooth roll. Each press section is driven by a 10hp (7.46 kW) electro motor.

The pressed paper is fed into the dryer section featuring a 1<sup>st</sup> dryer section with 13 dryer cylinders. The first dryer cylinder has a diameter of 24" (609.6 mm). The remaining dryer cylinders have a diameter of 48" (1219.2 mm). The dryer section is driven by interlocking gear drive powered by a 30 hp (22.37 kW) electromotor. The 2<sup>nd</sup> dryer section contains five 48" (1219.2 mm) diameter drying cylinders driven by an interlocking gear drive powered by a 20 hp (14.91 kW) electromotor. All dryers in the drying section are supplied with steam at a pressure of up to 15 psi (103.42 kPa).

Afterwards, the drying section the paper is transferred through a 7-roll vertical calendar stack. The first roll (top roll) has a diameter of 14" and a weight of 4000 lbs (kg). The 3<sup>rd</sup>, 4<sup>th</sup>, and 5<sup>th</sup> roll have a diameter of 10" (mm) and a weight of 2500 lbs (kg). The 5<sup>th</sup> and 6<sup>th</sup> roll have a

diameter of 13" (mm) and a weight of 4000 lbs (kg). The 7<sup>th</sup> roll is the supporting and drive roll with a diameter of 20" (mm) and is driven by a 40 hp (29.83 kW) electro motor.

The finished paper is rolled up at a two-roll reel section into paper rolls of up to approximately 750 lbs. (340 kg) each. The reel is powered by a 20 hp (14.91 kW) electro motor. The SCFPM can produce a finished paper product with a basis weight between 20 g/m<sup>2</sup> and 750 g/m<sup>2</sup> at a width of up to 44" (1118 mm) at a maximum speed of up to 350 ft/min (106.7 m/min).

The total installed electrical power of the wet end system, the SCFMP, and SCFPM vacuum system is 83 hp (61.89 kW), 151 hp (112.60 kW), 100 hp (74.57 kW) respectively, with a total installed electrical power of 234 hp (174.49 kW) for the complete paper production system.

The steam for the FCFPM dryer section is supplied as low-pressure steam at 15 psi (103.42 kPa).

UNDER PEER REVIEW

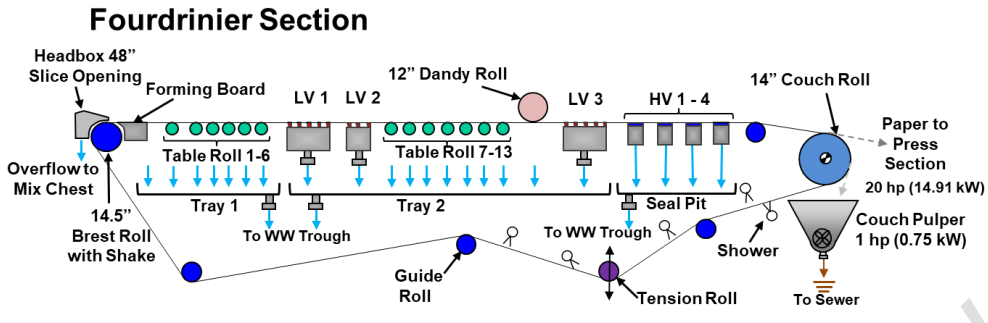

### Press Section

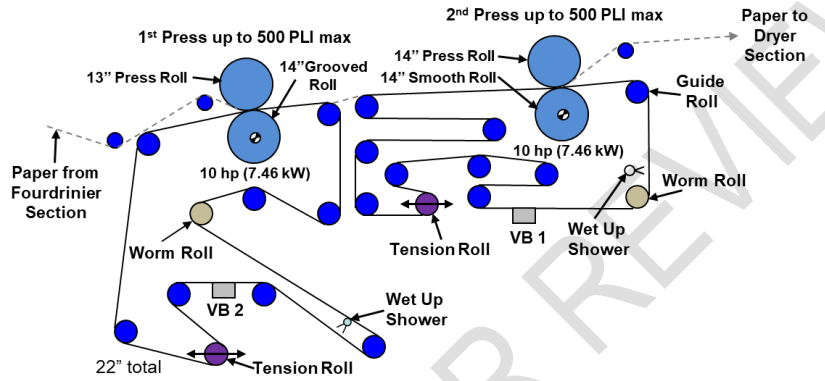

### Dryer Section 1

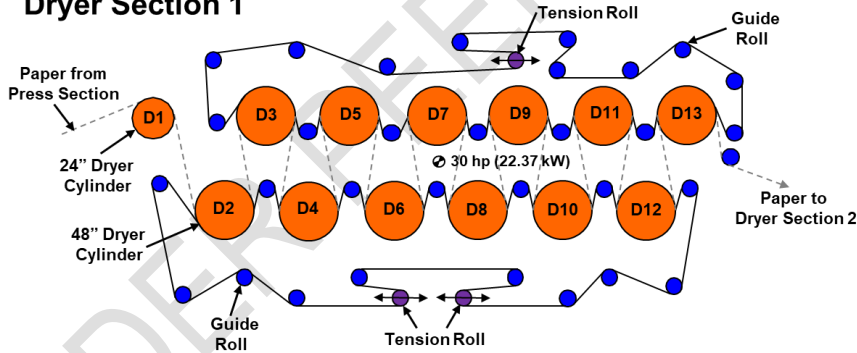

### Dryer Section 2, Calendar and Reel

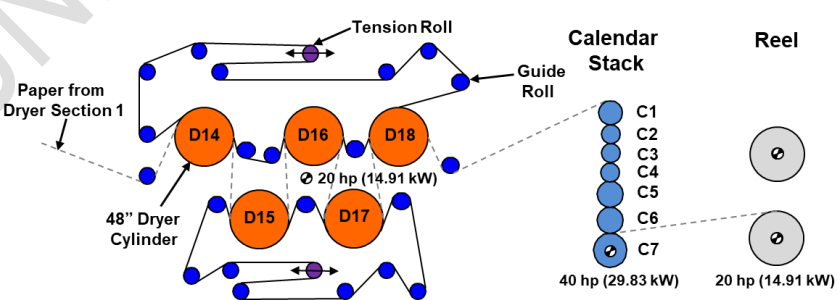

Fig. 9. 48-inch small commercial Fourdrinier paper machine [25].

### 3. RESULTS AND DISCUSSION

All tests for this research and development project were performed in accordance to the in Section 2.2. referenced TAPPI and ISO methods. All results stayed in the precision statements for the referenced TAPPI and ISO methods.

#### 3.1. Handsheet Development

The original furnish selection made by a TAPPI handsheet study and the large 12-inch square handsheet formed was 90% NBHK maple pulp and 10% BEK based on the theoretical fiber optical/printing properties and a positive effect on smoothness and printability based on short hardwood fibers. Both pulps were refined to 300 CSF and handsheets were formed for testing the physical properties. The TAPPI handsheets performed very poor for testing the printability of the paper. To resolve this issue, a 12-inch square mold was used in the next step to create larger sheets of paper. When attempting to synthesize sheets of the 90% NBHK and 10% BEK pulp, it was extremely difficult to create a sheet that wouldn't fall apart during either the pressing or drying portion of the sheet forming process. It became evident that the runability of the sheet would become an issue with this furnish, and alternative options needed to be explored.

The next furnish to be attempted was a combination of 90% NBHK and 10% NBSK pulp. By replacing the BEK pulp with NBSK pulp for strength and sheet integrity. Improvements were seen during TAPPI handsheet making and handsheet making with the 12-inch square handsheet mold, allowing to produce good handsheets for a printing evaluation by the artist.

To improve art paper sheet properties a sizing evaluation was conducted in a third step using the 12-inch square handsheet mold. The development focused on using AKD to help with the hydrophobicity of the paper and cationic starch to help stabilize the AKD and anchor better to the fibers. The right sizing will allow the creation of a sheet, that would accept water-based inks without letting the image bleed.

The preparation of the starch was done prior to the trial by adding 9 g cationic starch to 291 ml distilled water at 20°C (68°F) in a 500 ml beaker and cooking the 3% starch solution for 30 min under constant stirring, using a Fischer Scientific stirring hot plate, at a temperature between 95°C and 98°C (203°F and 208°F) [27,28].

0.25% Starch was added based on OD fiber content to a 0.3% fiber suspension containing 90% NBHK and 10% NBSK pulp and thoroughly mixed for 5 minutes. The starch addition was based on a chemical supplier recommendation. Then AKD was added as a 19% solution with levels ranging from zero to 1.0 percent, with intervals of .25 percent based on OD fiber content and mixed again thoroughly for 5 minutes after each addition. In between each interval handsheets were prepared with the 12-inch handsheet maker before the next AKD addition was done.

After handsheets were made the artist s performed a print evaluation and selected the paper with the .75% AKD addition.

The fourth step included an investigation how much starch is needed for tensile strength basis. This evaluation was done by creating 80 g/m<sup>2</sup> handsheets with starch levels ranging from 0% to 3.5% percent in 0.5% increments. Handsheets were prepared as in the previous step. The handsheets were then tested for tensile strength, indexed to the basis weight of the handsheet and the values compared to that of the current art paper the artists are using.

The tests showed as displayed in Figure 10, that between 0 and 0.5 percent starch addition there wasn't a very large increase in tensile strength, both at about 45 N·m/g, but still greater than the tensile strength of the 40 N·m/g of the art paper used by the artist currently. It was therefore decided to use 0.25% starch addition, as that was the chemical manufacturers recommended minimum starch addition for the use with the AKD.

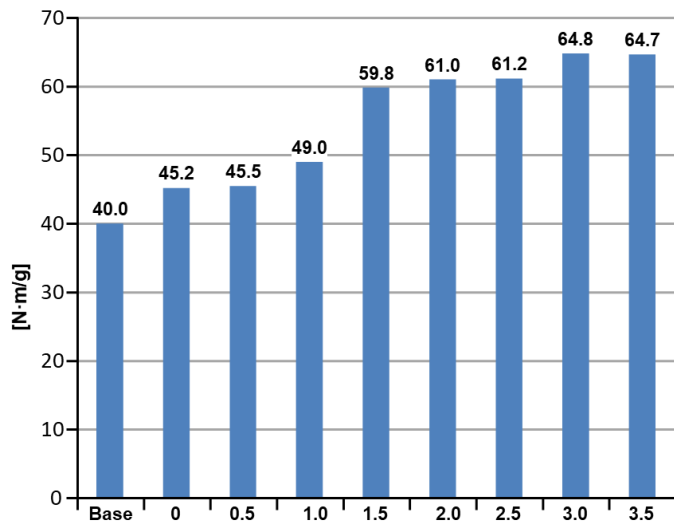

**Fig. 10. Tensile index comparison from starch addition**

The fifth step included color matching to the artist preferred color a bluish-gray, using dyes that were from Kemira. The colour preference was achieved during the laboratory development by adding 2.437 lbs/short ton (1139.6 g/metric ton) of yellow dye, 0.088 lbs/short ton (44.0 g/metric ton) of red dye, 0.075 lbs/short ton (37.5 g/metric ton) of blue dye, and 0.281 lbs/short ton (140.5 g/metric ton) black dye to the 90% NBHK and 10% NBSK pulp fiber mixture.

The sixth step included an addition of GCC at 5% to increase printability. After color was matched and GCC at 5% was added to the fiber suspension, white spots were seen in the produced handsheets, where the color was not binding to the filler. The artist decided not to use GCC for the SPAP product.

### **3.2. Screen Printing Art Paper Properties based on Laboratory Development.**

Based on the laboratory handsheet development, the selected final fiber mixture (70% NBHK and 30% NBSK pulp) will need to be beaten to 300 ml CSF for the NBHK and a 500 ml CSF value for the NBSK pulp prior to papermaking. AKD and starch would be added at 0.75% and 0.25% respectively. No other additives will be added to the pulp suspension during the papermaking process. The artists request for the paper to be able to be more lightweight, thinner, and more “Japanese” style of a printing paper it was decided to test for basis weight using TAPPI T410 method. Thickness was tested using TAPPI T411 method. Basis weight and thickness target were set at 80 g/m<sup>2</sup>, 125 μm respectively. The finished moisture content of the paper should be in the range of 94% to 99% measured with TAPPI method T412.

Tensile strength tested according to T494 became a necessary specification to ensure that the paper would be strong enough to be pulled through the various printers at the artists facility without failure. The targeted tensile index was set 49 N·m/g. It was decided by the artist that roughness, according to TAPPI test method T 538, as a key surface property requirement for printing as another key property. The roughness target value was set to be 1800 ml/min for the top side and 1400 ml/min for the wire side.

A spec for water absorptiveness was created to ensure printability with water-based inks and tested with TAPPI T411 method. The target for water absorbency was 28 g/m<sup>2</sup>. A bending stiffness was added because the artist did not want the paper too stiff and rigid. Bending stiffness was tested according to TAPPI method T 489. The targeted bending stiffness was 0.21mNm. The color target for the bluish gray colour was set at ISO brightness level

according to the ISO 2470 at 69.83% and a color value according to the ISO 11476 method for L\*, a\*, b\*. at 64.50, -2.73, and -1.04, respectively.

### 3.3. 12-inch Laboratory Fourdrinier Paper Machine Run

The LFPM run is using NBHK and NBSK pulp fibers and is designed for a maximum of approximately 3 hours, producing a sheet at 80g/m<sup>2</sup>. This will leave enough time to start-up the LFPM, make needed adjustments to meet paper properties, and produce enough pulp for the printing evaluation by the artist.

For the LFPM run a total of 24 lbs (10.9 kg) OD of the 90% NBHK and 10% NBSK virgin pulp fiber mixture was pulped. First, 21.6 lbs (9.8 kg) of NBHK were pulped in two batches of 25.9 gal (98.0 l) each at a consistency of 5% using the 35 gal (132.5 l) low consistency laboratory pulper of the LFPM stock preparation system and transferred into the 1<sup>st</sup> 240-gal (908.5 l) storage chest. Second, 4.8 lbs (2.2 kg) of NBSK was pulped in a batch of 11.6 gal (44.0 l) at a consistency of 5% using the 35 gal (132.5 l) low consistency laboratory pulper of the LFPM stock preparation system and then transferred into the 2<sup>nd</sup> 240-gal (908.5 l) storage chest. After pulping the 51.8-gal. (196.0 l) NBHK and 11.6-gal (44.0 l) NBSK pulp fiber slurry was then diluted to a consistency of 3% by adding 34.1 gal. (128.8 l) and 7.7 gal. (29.3 l) water respectively for refining. Second, the NBHK and NBSK pulp slurry was then refined to a CSF value of 300 ml and 500 ml with a Jordan conical refiner under a 1.5 Amp net load by carefully monitoring in 5-minute intervals. CSF value was measured with TAPPI test method T 227 om-09. After refining the NBHK and NBSK fiber slurry was diluted to a machine chest consistency of 1.5% by adding 86.5 gal (326.9 l) of water to the NBHK pulp and 19.4 gal (73.3 l) to the NBSK pulp. This resulted in 172.9 gal (653.7 l) of the NBHK and 38.8 gal (146.6 l) NBSK pulp fiber mixture at 1.5% consistency. available for the art paper production.

Third, to the 172.9 gal (653.7 l) of the NBHK pulp in the 1<sup>st</sup> storage chest, 19.4 gal (73.3 l) NBSK pulp fiber mixture was added to achieve the 90% NBHK and 10% NBSK fiber mixture. The total fiber mixture available for paper production was 192.3 gal (727 l). The remaining NBSK pulp mixture was set aside for emergency use.

Fourth, AKD as a 19% solution, and starch, as prepared under Section 3.1 were added at 0.75% and 0.25% respectively based on OD fiber content to the 240-gal (908.5 l) storage chest. No retention aid was used due to the high retention rate (above 80%) of the LFPM.

Fifth, to the 1.5% NBHK and NBSK pulp fiber mixture 0.182g anionic blue dye, and 0.724g cationic red, and 3.63g yellow dye were added to the prepared batch and mixed in with the machine chest agitator.

Sixth, the final production values of FPM paper machine run was conducted containing the following:

- a) The LFPM was operated at a speed of 6 ft/min (1.8 m/min) for the SPAP production run. Vacuum levels for the fourdrinier table were set at 0 for the 1<sup>st</sup>, 27579 Pa for the second vacuum section, 0 for the 3<sup>rd</sup> to 6<sup>th</sup>, 13789 Pa for the 7<sup>th</sup>, 27579 Pa for the 8<sup>th</sup>, 48263 Pa for the 9<sup>th</sup>, and 0 for the 10<sup>th</sup> vacuum section. The final fiber flow to the headbox at a consistency of 1% was set at 1.1 gal/min (4.15 l/min) to achieve the desired basis weight of the art paper product.
- b) The 1<sup>st</sup> and 2<sup>nd</sup> press was operated at 10 psi (68947 Pa) and 15 psi (103421 Pa) for all adjustment of the art grade.
- c) The heat of the Yankee-Dryer (J1) in dryer section 1 was kept at 182.2°C (390°F). The heat for the dryers in dryer section 2 is kept at 198.9°C (390°F) for the 1<sup>st</sup> to the 5<sup>th</sup> dryer (D1-D5), 201.6°C (395°F) for the 6<sup>th</sup> and 7<sup>th</sup> (D6 & D7) dryer, 204.4°C (400°F) for the 8<sup>th</sup> and 9<sup>th</sup> (D8 & D9) dryer, 207.2°C (405°F) for the 10<sup>th</sup> and 11<sup>th</sup> (D10 & D11) dryer, and 210.0°C (410°F) for the 12<sup>th</sup> and 13<sup>th</sup> (D12 & D13) dryer. The heat in dryer section 3 was kept at 215.5°C (420°F) for the 14<sup>th</sup> and 15<sup>th</sup> (D14 & D15) dryer, 218.3°C (425°F) for the 16<sup>th</sup> and 17<sup>th</sup> (D16 & D17) dryer, and 221.1°C (430°F) for the 19<sup>th</sup> and 19<sup>th</sup> (D18 & D19) dryer.

- d) The calendar section operated without pressure and heat. At the end of the LFPM SPAP run the calender section was operated at 20 psi (137895 Pa), 30 psi (206843 PA), and 50 psi (344738 PA) to evaluate the impact of calendaring on the final SPAP paper properties. After the calendaring section the SPAP was rolled up and the paper rolls were conditioned according to TAPPI Test method T402 before cut in size for testing and print evaluation.

During the LFPM run on the SPAP furnish had runability issues in regards to wet picking (partial deformation of the paper surface) caused most likely by the low surface strength of the paper furnish directly related to its hardwood/softwood ratio and basis weight.

To eliminate the picking problem the furnish selection for the 48-inch SCFPM run was changes to a 70% NBHK pulp and 30% NBSK pulp as fiber material.

#### **3.4. 48-inch Small Commercial Fourdrinier Paper Machine Run**

The SCFPM art paper run using NBHK and NBSK pulp fibers was designed for a maximum of approximately 3.0 hours, producing a sheet at 68 g/m<sup>2</sup>. This will leave enough time to start-up the SCFPM, make needed adjustments to meet paper properties, and produce about 770 lbs (350 kg) art paper.

First, 700 lbs (454 kg) OD of NBHK, representing 70% of the pulp, and 300 lbs (136 kg) of NBSK, representing 30% of the pulp, were pulped in two batches of 1200 gal (4,540 l) for the NBHK and 1 batch of 719 gal (2,720 l) for the NBSK at a consistency of approximately 5% using the 1800 gal (6800 l) low consistency pulper of the SCFPM stock preparation system.

The NBHK batch from the low consistency pulper was split in half (600 gal, 2,270 l) and transferred to Jones Bertram Beater, then diluted to a consistency of 3.3% by adding 1200-gal (4,536 l) water. The 1800 gal (6800 l) NBHK pulp slurry was then refined to a CSF value of 300 ml. Each batch was transferred after refining into the 15,000-gal (56.78 m<sup>3</sup>) machine chest.

The NBSK was transferred into the Jones Bertram Beater and diluted to a consistency of 4.0% by adding 181-gal (684 l) water and refined to a CSF value of 500 ml.

The CSF value was measured with TAPPI test method T 227 om-09. After refining each batch of the refined fiber slurry was transferred into the 15,000-gal (56.78 m<sup>3</sup>) machine chest of the SCFPM and mixed thoroughly.

The 5,400 gal (20,412 l) of refined pulp fiber slurry in the machine chest was then diluted to a consistency of 2.5% by adding gal (3,188l) of water.

Third, AKD as a 19% solution, and starch prepared with a laboratory jet cooker at 95°C and 98°C (203°F and 208°F), were added at 0.75% and 0.25% respectively based on OD fiber content to the 15,000-gal (56.78 m<sup>3</sup>) machine chest. l (908.5 l) storage chest.

Fourth, to the 2.5% refined NBHK and NBSK pulp fiber mixture 21.8 g anionic blue dye, and 87.16 g cationic red, and 435.4 g yellow dye were added to the prepared batch and mixed in with the machine chest agitator.

Fifth, the FPM paper machine run was conducted containing the following:

- a) The FPPM was operated for the art grade production at a speed of 128 ft/min (38.9 m/min), with a headbox slice opening of 0.35 inch (8.9 mm), and a shake frequency of 5.2 strokes per second. The vacuum levels for the fourdrinier table were set for the three low vacuum boxes 1 to 3 at 497 Pa, 1493 Pa, and 2488 Pa respectively. The four high vacuum boxes 1 to 4, the vacuum was set at 1244 Pa, 1368 Pa, 995 Pa, and 0 Pa respectively. The couch roll vacuum was set at 1368 Pa. The fiber suspension flow to the headbox was adjusted to 1.1% in the mixing chest by recirculating the white water from the white-water through with an fiber suspension flow of 151 gal/min (373 l/min) (see Figure 8), in order to achieve the targeted basis weight of g/m<sup>2</sup> of the art paper.

The 12-inch LFPM has a retention above 80%, therefore no retention aid needed to be added. To increase the retention of the SCFPM a retention aid in form of a cationic acrylamide copolymer (cPAM) was added at the fan pump at 0.75 lbs/short ton (0.375 kg/

metric ton) to increase retention on the SCFPM. The produced art paper had a solids content of 21% after the fourdrinier couch roll before entering the 1<sup>st</sup> Press.

- b) The 1<sup>st</sup> and 2<sup>nd</sup> press was operated at 10 psi and 20 psi pressure respectively, which correlates to a line pressure of 7.0 N/mm for the 1<sup>st</sup> and 20.8 N/mm for the 2<sup>nd</sup> press. The achieved solids content of the fiber mat for the art paper was 34.43% after the 1<sup>st</sup> Press and 39.9% after the 2<sup>nd</sup> press. The wet art paper fiber mat is then fed into the 1<sup>st</sup> dryer section with a solids content of 39.9% from the 2<sup>nd</sup> press section.
- c) The two dryer sections of the SCFPM, as shown in Figure 9, contain eighteen dryer cans D1 to D18. The seam supply for the first dryer section was at 7.5 psi (51710 Pa) and for the second dryer section at 10 psi (68947 Pa). For the screen print art paper production run dryer can D1 to D3 were operated at a temperature of 195°F (90.6°C), 186°F (85.6°C), and 197°F (92.2°C) respectively. Dryer can D4 was not heated and had a temperature of 133°F (56.1°C). Dryer can D5 to D 8 were heated with temperatures of 209°F (98.3°C), 209°F (98.3°C), 215°F (101.7°C), and 218°F (103.3°C) respectively. Dryer can D9 to D14 were turned off and had temperatures of 151°F (66.1°C), 139°F (59.4°C), 146°F (63.3°C), 135°F (57.2°C), 122°F (50.0°C), and 123°F (50.6°C) respectively. Dryer can D15 was heated to 219°F (103.9°C). Dryer can D16 to D18 were not heated but temperatures reached 174°F (78.9°C), 145°F (62.8°C), and 124°F (51.1°C) respectively. The produced art paper for screen printing had a solids content of 95± 2%.
- d) The calendar section was operated without pressure for all production runs. The produced art paper was reeled to rolls with a maximum weight of approximately 500 lbs (227 kg) with a solids content of 95± 2%.
- e) The paper rolls were converted into smaller rolls with a length of approximately 100 ft (30m) and paper sheets with a size of 44-inch x 36-inch (1118 mm x 914 mm) for further processing and printing of the art paper.

### 3.5. Paper Testing Results

Paper testing results of the art paper produced with the 12-inch PM and 48-inch PM are shown in Fig. 11 to 18, including target values based on the handsheet development.

Fig. 10. shows the art paper basis weight and caliper was target at 80 g and 125 µm respectively. The 12-inch PM and 48-inch PM run achieved a basis weight of 87 g and 63 g a and a caliper of 151 µm and 94 µm respectively. The basis weight for the 12-inch run was 8.7% higher and for the 48-inch run 21.2% lower than the set target value. The thickness of the art paper was for the 12-inch PM and 48-inch PM run 20.8% and 20.8% lower respectively. However, The artist liked the lower basis weight and associated thickness of the paper since it represented more his desire for a lightweight paper printing product.

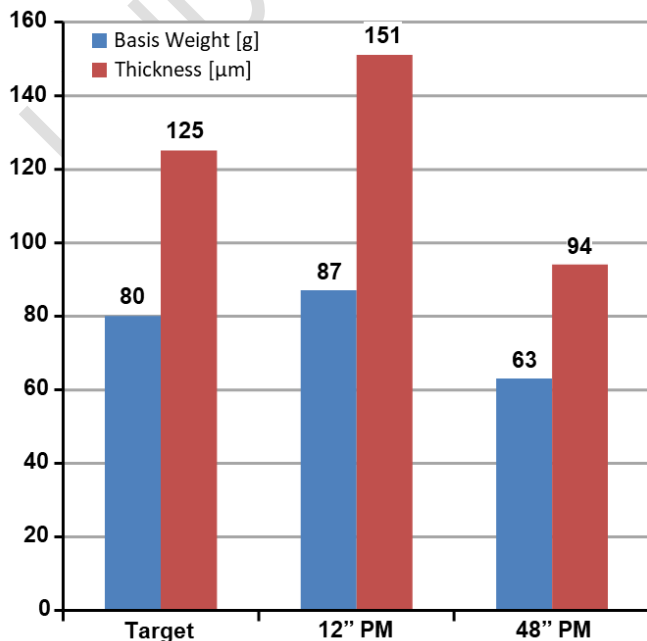

**Fig. 11. Art paper basis weight and calliper**

Fig. 12. shows the art paper porosity value with the set target at 1800 ml/min for the top site and 1400 ml/min for the wire side of the art paper product. The 12-inch PM and 48-inch PM run achieved a porosity of 14850 ml/min for the top site and 1341 ml/min for the wire side. The 48-inch PM production run achieved and 1703 ml/min for the top side and 1336 ml/min for the wire side. The porosity for the 12-inch and 48-inch PM run was 17.5 % and 5.4% lower for the top side and 4.2% and 7.1% lower for the wire side. Overall, the product met the artists expectations.

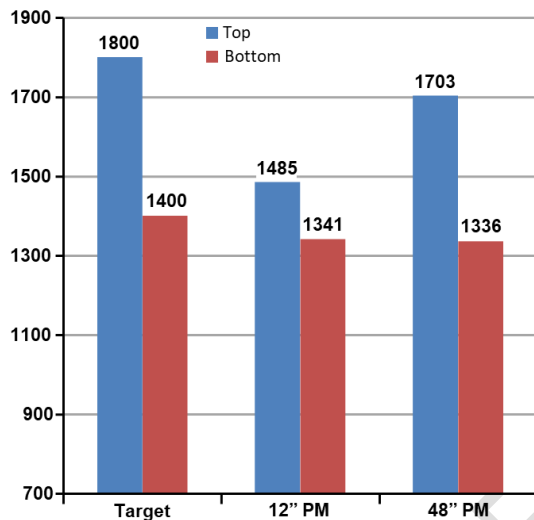

**Fig. 12. Art paper porosity**

Fig. 13. shows the produced art paper bending stiffness in MD and CD direction, including the targeted bending stiffness of 21 mN and 14 mN respectively based on the laboratory development. The 12-inch PM and 48-inch PM run achieved a bending stiffness of 18 mN and 15 mN for the MD and CD direction and 22mN and 12 mN for the MD and CD respectively. For the 12-inch PM run the bending stiffness was 14.3% lower for the MD and 7.1% higher for the CD than the set target value. The bending stiffness for the 48-inch PM run was 4.7% higher for the MD and 14.3% lower for the CD direction. Overall, the product met the artists expectations.

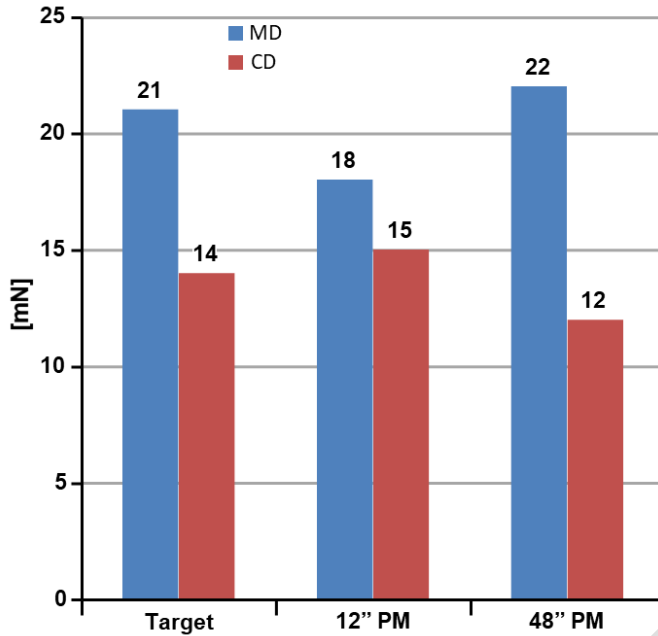

**Fig. 13** Art paper bending stiffness

Fig. 14. shows the produced art paper tensile index in MD and CD direction, including the targeted tensile index of 49.0 N·m/g and 30.0 N·m/g respectively based on the laboratory development. The 12-inch PM and 48-inch PM run achieved a tensile index of 38.1 N·m/g and 19.7 N·m/g for the MD and CD direction and 52.9 N·m/g and 31.6 N·m/g for the MD and CD respectively. For the 12-inch PM run the tensile index was 22.2% for the MD and 34.3% for the CD lower than the set target value. The bending stiffness for the 48-inch PM run was 7.79% for the MD and 5.3% for the CD direction higher than the set target value, exceeding the artists product expectations.

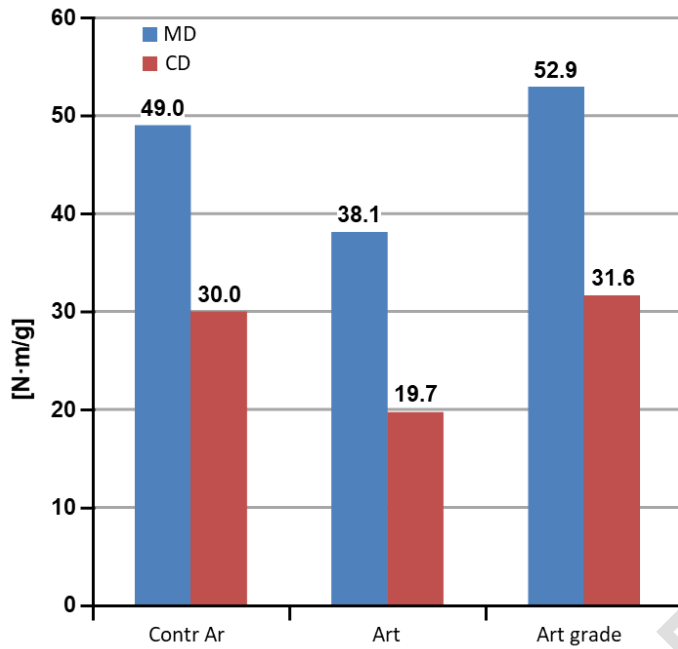

**Fig. 14.** Art paper tensile index

Fig. 15. shows the art paper Cobb number. The target from the paper development was set at 28.0 g/m<sup>2</sup>. The art paper produced with the 12-inch PM and 48-inch PM run achieved a cobb number of 27.9 g/m<sup>2</sup> and 28.9 g/m<sup>2</sup> respectively. The cobb number of the art paper was for the 12-inch PM slightly lower than the target and for the 48-inch PM run 3.2% higher than the target, meeting the artists expectations.

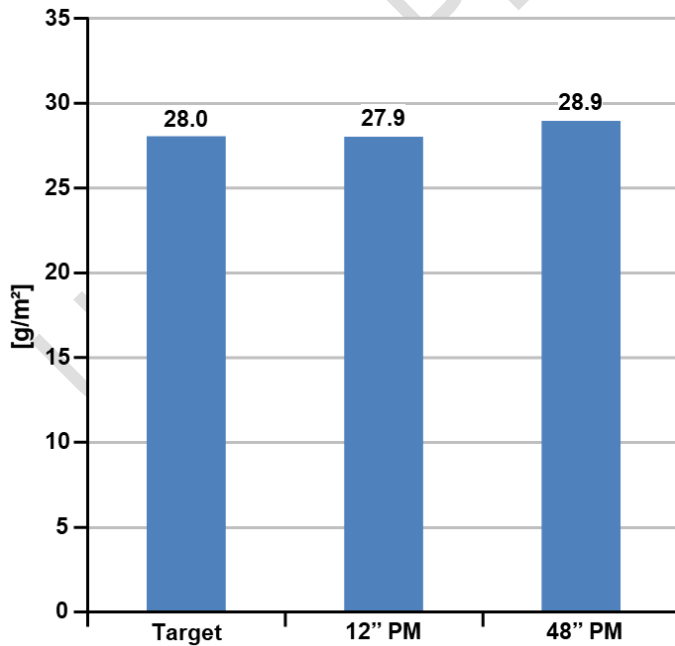

**Fig. 15.** Art paper cobb number

Fig. 16. shows the art paper brightness value with the set target at 68.8%. The 12-inch PM and 48-inch PM run achieved a brightness value of 40.3% and 35.6% respectively. The brightness for the 12-inch PM run was 42.2% lower and for the 48-inch PM run 94.3% lower than the set target value. However, the artist liked the achieved brightness better than the targeted number and accepted the produced art paper.

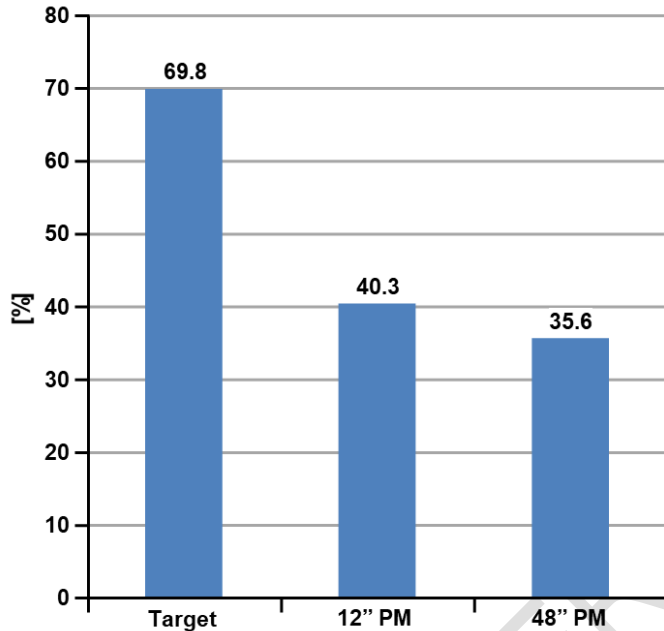
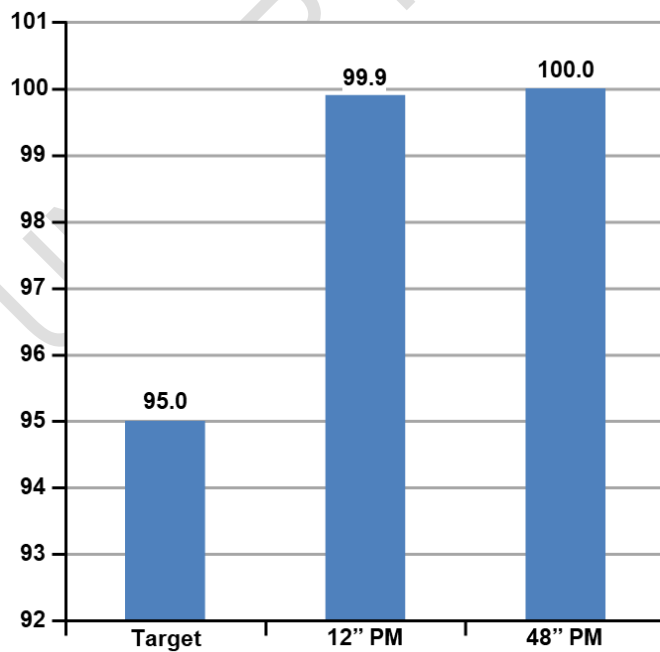

Fig. 16. Paper machine run brightness

Fig. 17. shows the art paper opacity value with the set target at 95.0%. The 12-inch PM and 48-inch PM run achieved a opacity value of 99.9% and 100.0% respectively. The opacity for the 12-inch PM run and the 48-inch PM run was 5.1% and 5.2% respectively above the targeted value, exceeding the artists product expectations.



**Fig. 17. Art paper opacity**

Fig. 18. shows the  $L^*$ ,  $a^*$ , and  $b^*$  color value of the produced art paper, including the targeted color value of 64.5% for the  $L^*$ -value, -2.7 for the  $a^*$ -value, and -1.0 for the  $b^*$ -value based on the laboratory development. The 12-inch PM run achieved a  $L^*$ ,  $a^*$ ,  $b^*$  color value of 72.0%, 1.9, 3.8 respectively. The 48-inch PM run achieved a  $L^*$ ,  $a^*$ ,  $b^*$  color value of 65.8%, 0.9, -0.7 respectively. For the 12-inch PM run the  $L^*$  color value was 70.4% higher and 480% times higher for  $a^*$  and the  $b^*$  colour. For the 48-inch PM run  $L^*$  colour value was 1.58% was 2.0% higher and the  $b^*$  and  $a^*$  colour value was 360% and 30.0% higher than the set target value. However, the artist liked the achieved colour values better than the targeted number and accepted the produced art paper.

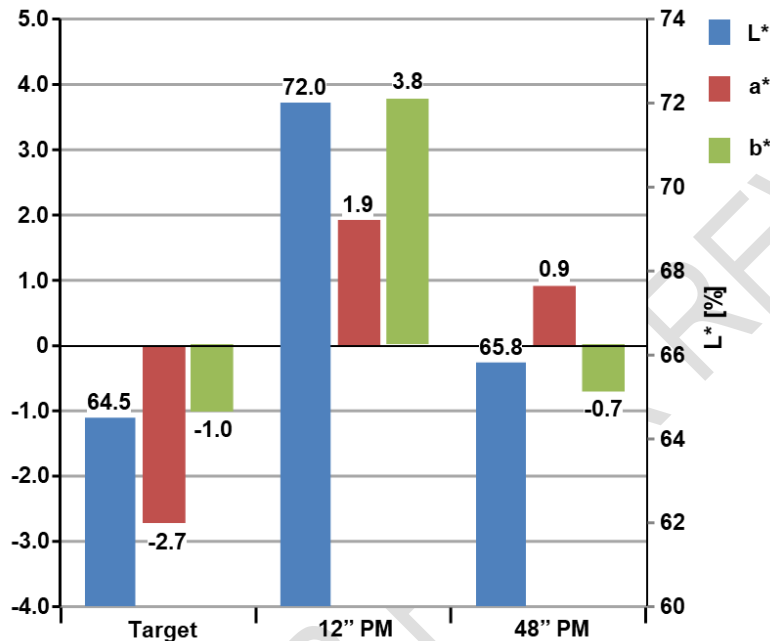

**Fig. 18. Art paper colour**

#### 4. CONCLUSION

The presented research project describes the development of an art paper product applicable for artistic screen printing applications from the handsheet development, laboratory scale paper machine run at 6ft/min (1.8 m/min) to large semi commercial production on a 48-inch (1219 mm) paper machine at a speed of 128 ft/min (38.9 m/min). The produced art paper will be used for studio art screen printing images up to 4 ft (1200mm) by 4 ft (1200 mm).

The development of the art paper showed an improvement throughout the development process for mechanical and optical paper properties. The developed art paper was evaluated during each process for its suitability for screen printing applications using water-based inks.

The produced art paper with a basis weight of 63 g/m<sup>2</sup> and a thickness of 94  $\mu$ m is produced from a mixture of 70% northern bleached hardwood Kraft pulp and 30% northern bleached softwood Kraft pulp.

The ISO brightness and opacity of the art paper bluish gray colour was at 35.6% and 100%, The ISO color value was for the L\*, a\*, b\* Hunter color scale 65.8%, 0.9, and 1-0.7 respectively.

As a parameter for attachment of water-based inks, surface roughness was for the top side 1703 ml/min and bottom side (wire side) 1336 ml/min. The Cobb number indicating water penetration of the art paper is 28.9 g/m<sup>2</sup>.

Bending stiffness in machine direction and cross machine direction resulted in 22 mN and 12 mN respectively. The tensile index was measured at 52.9 N·m/g for the machine direction and 31.6 N·m/g for de cross-machine direction.

The finished art paper product exceeded the expectations by the artists using the art paper for screen printing images in the art studio.

## **7. ACKNOWLEDGEMENT**

The authors are grateful for the support provided by the Department of Chemical Engineering at SUNY-ESF.

## **8. COMPETING INTERESTS DISCLAIMER**

Authors have declared that no competing interests exist. The products used for this research are commonly and predominantly use products in our area of research and country. There is absolutely no conflict of interest between the authors and producers of the products because we do not intend to use these products as an avenue for any litigation but for the advancement of knowledge. Also, the research was not funded by the producing company rather it was funded by personal efforts of the authors.

## **9. REFERENCES**

1. Tschudin, P.F., (1999), „Vom Tapa-Kofer zur Papiermaschine: Technikgeschichte der besonderen Art“, Wochenblatt für Papierfabrikation, 23/24, 1541-1545.
2. Doelle K., (2012), „Lime in Papermaking – A Historic Review Paper“, In: Thompson M.L., Brisch J.H., editors, Lime: Building on the 100-Year Legacy of The ASTM Committee C07American, Society for Testing and Materials (ASTM), ASTM International STP 1557, October. 2012, pp 178–195.
3. Doelle K., Amaya J.J., (2012), “Application of calcium carbonate for uncoated digital printing paper from 100% eucalyptus pulp”, TAPPI JOURNAL, Jan. 2012, Vol. 11 No.1, pp 41-49.
4. Hubbe MA, Rosencrance S. Advances in Papermaking Wet End Chemistry Application Technologies. TAPPI Press. 2018.
5. Voith Paper. Hainan PM2 – The largest paper machine in the world. Together Paper Technology Journal 31. 2010.
6. Paper Age. Papierfabrik Palm Successfully Commissions New Containerboard Machine, PM5, in Aalen, Germany. Retrieved 12/08/2021. Available from: [https://www.paperage.com/2021news/07\\_09\\_2021palm\\_startsup\\_pm5.html](https://www.paperage.com/2021news/07_09_2021palm_startsup_pm5.html)
7. Sullivan C. History of Screen Printing. California State University Chico. 2011. Retrieved 11/20/2021. Available from: [https://www.csuchico.edu/turner/\\_assets/documents/history-of-screen-printing.pdf](https://www.csuchico.edu/turner/_assets/documents/history-of-screen-printing.pdf)
8. Hubbe MA. Paper's Resistance to wetting – A Review of Internal Sizing Chemicals and their Effects. Bioresources. 2006;2(1):106-145.
9. TAPPI T 200 sp-06 Laboratory beating of pulp (Valley beater method)

10. TAPPI T 205 sp-12. Forming handsheets for physical tests of pulp.
11. TAPPI T 220 sp10. Physical testing of pulp handsheets.
12. TAPPI T 227 om-09. Freeness of pulp (Canadian standard method).
13. TAPPI T 240 om-07 "Consistency (concentration) of pulp suspensions
14. TAPPI T 402 sp-13. Standard conditioning and testing atmospheres for paper, board, pulp handsheets.
15. TAPPI T 410 om-08. Grammage of Paper and Paperboard (weight per unit area).
16. TAPPI T 411 om-10. Thickness (caliper) of paper, paperboard, and combined board.
17. TAPPI T 412 om-06. Moisture in pulp, paper and paperboard.
18. TAPPI T 411 om-04 Water absorptiveness of sized (non-bibulous) paper, paperboard, and corrugated fiberboard (Cobb test) resistance.
19. TAPPI T 489 om-08 "Bending resistance (stiffness) of paper and paperboard (Taber-type tester in basic configuration).
20. TAPPI T494 om-06 Tensile properties of paper and paperboard (using constant rate of elongation apparatus).
21. TAPPI T 538 om-08. Roughness of Paper and Paperboard (Sheffield method).
22. ISO 2470 "Paper, board and pulps - Measurement of diffuse blue reflectance factor – Part 1: Indoor daylight conditions (ISO Brightness).
23. ISO 2471:2008 Paper and Board: Determination of Opacity (Paper Backing) – Diffuse Reflectance Method.
24. ISO 11476:2016 Paper and Board – determination of CIE Whiteness, C/2° (Indoor Illumination Conditions).
25. Dölle K, Rainville H. Art Paper for Large Wood Relief Block Printing – A Paper Development Study. Journal of engineering Research and Reports (JERR). 2021;21(7):1-18.
26. Dölle K. Screen print test image. pdf-file.
27. Dölle K, Parsons E, Konecny J. Application of Cationic tapioca to Unmodified Pearl Corn Starch – A Papermaking Handsheet Study. Journal of Engineering Research and Reports. 2020;9(4):1-7.
28. Dölle K, Sonntag J, Fischer K, Dominesey T. Improvement of Fiber Fines Retention and Mechanical Properties of Board Paper Using Corn and Tapioca Starch - A Handsheet Study. Journal of Engineering Research and Reports. 2021:20(1):39-50.