

Original Research Article

Prediction of gene action, Heterosis and Combining ability to identify superior GMS based hybrids in Asiatic Cotton (*G. arboreum* L.)

Abstract

The nature of gene action and combining ability is valuable in determining whether heterosis is fixable or predictable. Thus, to know the nature of gene action of seed cotton yield and its components and fibre quality parameters, seventeen parents (15 males and two genetic male sterile lines) and 30 F1 crosses (genetic male sterility based) were evaluated in a line x tester mating design of Asiatic cotton (*Gossypium arboreum* L.). Sufficient variability among hybrids and their parents was found as the mean squares of genotypes for all the traits including fibre quality parameters investigated were significant. The total genetic variability was partitioned to general combining ability (GCA) and specific combining ability (SCA) effects. GCA was significant for male parents HD-123, RG-270, CISA-59, CISA-64, CISA-65, CISA-66 and LD-694 for seed cotton yield (SCY); HD-123, RG-286 and DLSA-24 for bolls per plant; HD-123, CISA-59, PAIG-8/3, DLSA-9 and LD-694 for boll weight; female parent DS-5, male parents HD-123, RG-18, CISA-65, and PAIG-8/3 for ginning outturn (GOT%); RG--270, RG-286, PAIG-8/3, DLSA-9 and LD-694 for 2.5% span length (mm); RG-286, CISA-59, CISA-66, PAIG-8/3 and LD-694 for lower micronaire value having fineness and HD-400, RG-270, RG-286, RG-341 CISA-60, CISA-66, PAIG-8/3 and LD-694 for tenacity (g/tex) which were considered as good general combiners. Similarly among 30 cross combinations, SCA was positively significant for 10 crosses for seed cotton yield, 10 crosses for boll number, 10 crosses for boll weight, 9 crosses for GOT(%), 10 crosses for 2.5% span length and 8 crosses for fibre strength (g/tex). Cluster III of yield attributing traits, consisted of 9 crosses (C3, C6, C18, C20, C26, C22, C23, C24, C30, and C8) showed the highest average seed cotton yield where as Cluster II of fibre quality traits consisted of 3 crosses (C2, C12, C15) showed highest average GOT(%) with highest tenacity (g/tex). Cross DS-5 x HD 123 for SCY and bolls per plant, DS-5 x DLSA 9 for boll weight, DS-5 x CISA 65 for GOT % , CISA-2 x CISA 66 for lower micronaire value (fibre fineness) showed significant estimation of heterosis in desirable direction and could be further utilized in the future breeding programme for specific trait improvement.

Key words: Gene action, combining ability, seed cotton yield, genetic male sterility, cluster analysis

Introduction

Cotton is the most important commercial and vital cash crop of India called “White Gold”, cultivated mainly for its fiber and other by-products important being the edible oil. It influences major economies of countries of the world such as the USA, China, India, Pakistan, Uzbekistan, Australia, Africa and others. India is the only country in world where all the four cultivated species of cotton (tetraploid and diploid) viz., *G. hirsutum*, *G. barbadense*, *G. arboreum* and *G. herbaceum* are grown from north to deep south. *G. hirsutum* covers more than 90% of acreage while the diploids the least, however, the diploids are relatively tolerant to biotic as well as abiotic stresses including less inputs as compared to *G. hirsutum* (Verma et al., 2020). Desi or diploid cotton (*Gossypium arboreum* L.; $2n = 26$) also known as Asiatic cotton has inherent ability to adapt adverse climatic conditions and is well known for being resistant to pests and diseases. They are still under cultivation in some parts of India as farmers believe the sustainability of the yield in marginal soil and less management practices (Mehetre, 2015). After

the introduction of Bt cotton in India, there was a significant decrease in the area of desi cotton. But there is a big demand for short staple length for denim and surgical cotton. As an alternative the diploid cotton may be taken if they are giving remuneration equal to or higher than *G. hirsutum*. The primary objective for any breeder is to enhance the yield per unit area, the fibre yield and improve its quality length, strength and fineness, particularly in cotton. Parents which are diverse genetically and geographically should be used for genetic gain, enhancement and improvement of yield and fibre quality in cotton per se. Yield being a complex character and components which contribute towards high yield potential in cotton need careful study. The first step in a successful breeding program is to select the most desired and appropriate parents. Several studies revealed the utility of combining ability analysis in cotton in predicting the prepotency based on the genetic information. The direction of gene action provides a systematic approach for detection of appropriate parents and crosses in terms of estimation of general and specific combining abilities in both self and cross pollinated plants (Kempthorne, 1957). In any breeding programme, the proper choice of parents depending upon their combining ability is a pre-requisite. In the present investigation, Line x Tester mating design was used to obtain information on combining ability and heterosis for yield components and fibre quality traits of genotypes obtained from different eco-geographical regions of India. The findings of early researchers revealed that variation in seed cotton yield and its components were controlled by genes having additive and non-additive gene action. This method has been used by many workers for analysis and identification of potential combiners in early generation (Verma et al. 2004 & 2005; Tuteja and Verma, 2011; Verma et al., 2017). Therefore, seeing the importance of combining ability of parents from diverse eco-geographical regions for various characters in cotton, a total of 30 crosses involving two genetic male sterile lines and 15 male parents of Asiatic cotton (*G. arboreum*) was studied for gene action, heterosis and combining ability estimates.

Materials and Methods

The experimental material utilized for the present study, consisted of 15 genetically diverse male parents belonging to diverse eco-geographical regions, viz. from the Northern zone of India: Punjab - LD-694; Haryana- HD-123, HD-400, CISA-59, CISA-60, CISA-64, CISA-65, CISA-66; Rajasthan- RG-270, RG-286, RG-341, RG-18, and from the central and southern zone of India: Karnataka- PAIG-8/3, DLSA-24 and DLSA-9) and 2 female GMS lines, viz, DS 5 and CISA 2 and crossed in a line x tester mating design at the ICAR-Central Institute for Cotton Research, Regional Station, Sirsa, Haryana 1250 55, India (29°32'36.1"N and 75°02'18.8"E) during *kharif* seasons (April to October) in the year 2017-18. Fifteen parents and 30 crosses were grown in a Randomized Block Design (RBD) with three replications and crop geometry of 67.5x45cm. The details of crosses and their respective codes were given in Table 1. Five random plants were selected to record the data on number of bolls/plant, plant height, monopodia, sympodia and boll weight. The data on seed cotton yield was recorded per plot of 10.8m² basis and converted to kg/ha. All the seed cotton samples were cleaned and ginned carefully in the laboratory for estimation of GOT % (ginning outturn percentage) and analyzed for fibre quality parameters, viz. 2.5% span length, Micronaire value and tenacity on High Volume Instrument (HVI) as per the standard methods.

Statistical analysis: The data were used for statistical analysis using the method developed by Kempthorne (1957) with the help of OPSTAT computer program which was developed by Chaudhary Charan Singh Haryana Agricultural University, Hissar, Haryana 125 004, India (Sheoran et al., 1998). Heterosis (%) over mid parent or relative heterosis (RH) and better parent

(HB) or Heterobeltiosis was calculated after computing heterosis of the respective parent by using the following equations:

$$\text{Heterosis over better parent (\%)} = (F1-BP)/BP \times 100$$

Here, F1=Mean of F1 individuals

BP=Mean of the better parent values

$$\text{Heterosis over mid parent (\%)} = (F1-MP)/MP \times 100$$

Here, F1=Mean of F1 individuals

MP=Mean of the mid parent values. The significance of heterosis was tested using 't' test.

Cluster analysis: Cluster analysis of 30 crosses were done using JMP PRO 14 (SAS Institute Inc., Cary, NC) software using squared Euclidian distance method.

Results

The analysis of variable (Table. 2) indicated that the mean squares of genotypes for all the traits including fibre quality investigated were significantly different, indicating the presence of sufficient variability among hybrids and their parents. Hence, further analysis for combining ability was possible. The total genetic variability was partitioned to general combining ability (GCA) and specific combining ability (SCA). The variance due to GCA was lower than SCA for all the traits. This is in accordance with previous results of Ahuja and Dhayal, 2007; CitinKadeni et al., 2009; Verma et al., 2004, Tuteja and Verma, 2011; Tuteja and Banga, 2013. The results are similar to the findings of Raufet al., 2006; Kumar et al., 2010; Monaicshree et al., 2013.

General combining ability

The GCA effects on parents are presented in Table 3. Estimates for seed cotton yield, the male parents HD-123, RG-270, CISA-59, CISA-64, CISA-65, CISA-66, LD-694 showed significant positive GCA effects and no female parent showed significant positive GCA effects, whereas other RG-286, RG-18, RG-341, CISA-60, PAIG-8/3, DLSA-24, DLSA-9 showed significant negative GCA effects. For seed cotton yield, the male parents HD-123, RG-270, LD-694 and female parent CISA 2 appeared to be a good general combiner. For a number of bolls/plants, the male parent HD-123, RG-286, DLSA-24, and female parents CISA-2 were general good combiner. For GOT (%) HD-123, RG-18, CISA-65, PAIG-8/3 DS-5 showed a significant positive GCA effect, so they may have good combinations. For boll weight male parent HD-123, CISA-59, PAIG-8/3, DLSA-9, LD-694 and no female parent showed significant positive GCA effects. For 2.5% span length the male parents RG-270, RG-286, PAIG-8/3, DLSA-9, LD-694 and CISA-2 female parents recorded significant positive GCA effects and were observed to be good general combiner for this trait, this may be due to as the male parents are having blood of genotypes from Central and South zone whereas other male parents HD-123, RG-341, RG-18, CISA-59, CISA-64, CISA-65, and DS-5 female parents were having significant negative GCA effects which may not be advisable to use these parents for improving this trait. For micronaire value male parents RG-286, CISA-59, CISA-66, PAIG-8/3, LD-694 and CISA-2 female parent exhibited significant negative GCA effects and observed to be good general combiner as lower micronaire value increases the fineness of cotton fibre. For Tenacity the male parents HD-400, RG-270, RG-286, RG-341, CISA-60, CISA-66, PAIG-8/3, LD-694 and CISA-2 female parents recorded significant positive GCA effects and appeared to be good general combiner (Table 3). Karademir et al., (2008) also observed high yielding quality hybrids were deducted with significant SCA effects for seed cotton yield and fibre characteristics while crossing 4 lines and 7 testers in line X tester mating system. Kumar et al., (2017) also confirmed that in case of *G. hirsutum* male parents HS180 and PUSA-1803 were best general combiner for seed cotton yield, number of bolls, ginning out turn, seed index, lint index and number of monopods when evaluated through line x tester manner.

Specific combining ability

The positive significant specific combining ability effects for seed cotton yield were predicted from C2, C3, C4, C6, C12, C14, C20, C23, C24, C26 cross combinations while negative significant SCA effects were predicted from C5, C8, C9, C11, C17, C18, C19, C21, C27, C29 cross combinations. For boll number C1, C4, C12, C13, C14, C17, C20, C23, C24, C25, C26 crosses had positive and significant estimates for SCA effects, the maximum being in case of C26. In case of GOT (%) C1, C2, C5, C22, C23, C25, C26, C28 recorded significant positive SCA effects. For boll weight positive and significant estimates for SCA effects were predicted from C4, C7, C12, C14, C15, C21, C23, C24, C25, C26. The cross combinations C2, C5, C6, C7, C10, C12, C14, C15, C18, C19, C23, C24, C25, C28 showed positive and significant SCA effects for 2.5% span length. For cotton fibre fineness (micronaire value), negative SCA effects are desirable as lower the micronaire value fine will be the cotton fibre. Negative and significant SCA effects were obtained from C1, C2, C6, C7, C12, C13, C19, C26, C29, C30 cross combinations. The crosses C2, C7, C10, C11, C12, C16, C18, C19, C20, C28 had positive and significant SCA effects for tenacity. The present study based on genetic male sterility in cotton revealed that additive variances were significant for fibre fineness and non-additive as well as additive gene effects for seed cotton yield, boll number, boll weight, ginning percentage, 2.5% span length and Tenacity. Similarly among 30 cross combinations, SCA was positively significant for 10 crosses for seed cotton yield, 11 crosses for boll number, 10 crosses for boll weight, 14 crosses for 2.5% span length, and 10 crosses for tenacity (Table 4). Similarly, Combining ability studies were carried out in cotton seed yield and fibre quality traits by utilizing 7 lines, 8 testers and their 56 hybrids with significant SCA effects for fiber quality traits in the desired direction in upland cotton by Srinivas et al., (2014).

Performance of Parents

The parents showed a significant variation in terms of seed cotton yield, ranging from 1128.60 kg/ha to 1915.17 kg/ha with a mean value of 155.19 kg/ha. The parent CISA-2 (1915.17 kg/ha) showed the highest seed cotton yield followed by parent RG-286 (1833.73 kg/ha) on the other hand the parent PAIG-8/36 (1128.60 kg/ha) showed the lowest Seed cotton yield. In terms of bolls per plant CISA-2 (43.17) showed the best result among all the parents except HD-400 (30.3) which ranged from 30.3 to 43.17 with a mean value of 38.0. The highest Boll weight was observed for the parent RG-34 (3.00 g) followed by CISA-59 (2.67g), CISA-60 (2.47g) and CISA-65 (2.47g). The lowest Boll wt. was observed in the parent RG-18 (1.93g). All the parents showed significant variation in terms of GOT% varied from 32.10 to 39.67 with a mean value of 35.73. The highest GOT% (39.67) was resulted by the parent HD-123 followed by PAIG-8/3 (37.5) and CISA-65 (33.6). The parent HD-123 (39.67) showed highest GOT% whereas the CISA-59 (32.1) showed the lowest GOT%. In the case of 2.5% Span length except for HD-123 (20.7cm) and HD-400 (20.3cm) all other parents showed a significantly higher value for the trait. The highest 2.5% Span length resulted in the parent DLSA-24 (25.7cm) followed by CISA-64 (25.4cm). The trait ranged from 20.30cm to 25.7cm with an average of 23.60cm. The parents showed significant variation in terms of MIC ranging from 5.80 to 8.20 with an average of 6.64. The parent HD-123 (8.20) showed the highest MIC followed by RG-270 (7.10) and RG-34 where as the parent LD-694 (5.80) and CISA-2 (5.80) showed the lowest micronaire value. As micronaire value signifies the fibre fineness, so lower micronaire value of any parent is desirable for the trait improvement. In case of tenacity, parents showed sufficient variation ranging from 16.17 g/tex to 20.33 g/tex with an average value of 18.65 g/tex. The parent DLSA-24 (20.33 g/tex), LD-694 (20.23 g/tex) and CISA-2 (20.23 g/tex) showed the best result in terms of tenacity

where as the parents HD-123 (16.17 g/tex) and RG-270 (16.6 g/tex) showed lower performance in terms of tenacity (Table 5).

Performance of the crosses

Thirty cross combination resulted from crossing 15 male and 2 female parents were evaluated for yield traits and fibre quality traits. Cluster analysis for yield traits (Seed cotton yield, Boll number/ plant and boll weight) showed four cluster with 8, 7, 9 and 6 crosses respectively (Table 6 & fig. 1). Cluster III, which consisted of 9 crosses (C3, C6, C18, C20, C26, C22, C23, C24, C30, and C8) showed the highest average seed cotton yield whereas Cluster I consisted of 8 crosses (C1, C4, C16, C12, C14, C7, C25, C15) showed highest average boll no./ plant and boll weight (fig. 1). In the case of fibre quality traits, the crosses grouped into four clusters consisted of 8, 3, 3 and 16 crosses respectively (fig. 2). Cluster II consisted of 3 crosses (C2, C12, C15) and showed the highest average GOT(%) with the highest tenacity (g/tex) also. On the other hand Cluster III consisted of 3 crosses (C19, C30, C26) that showed highest average 2.5% span length and lowest micronaire value (Table 7 & fig. 2). Crosses with lower micronaire value is desirable as lower the micronaire value higher the fibre fineness of that cross will have (Supplementary Table 1). The crosses with negative significant heterosis value for the trait micronaire were identified through the estimation of heterosis over mid and better parent values. It is not so easy to identify the crosses that performed better in the traits. To identify the best performing cross for in particular trait magnitude of heterosis was also estimated.

Estimation of Heterosis

Thirty cross combinations resulted from crosses among 15 male and 2 female parents who were evaluated for heterosis over both mid parent and better parent. The crosses with more than 10% positive heterosis were considered as better performers among all the crosses. The magnitude of heterosis was estimated for three yield attributing (SCY, Boll no. and Boll wt.) and four fibre quality (GOT%, 2.5% span length, micronaire and tenacity) traits. For Seed Cotton Yield six crosses showed more than 10% heterosis over mid parent whereas crosses C1 (DS-5x HD-123) and C15 (DS-5 x LD-694) showed more than 10% heterosis over both mid parent and better parent. In case of Boll number/ Plant five crosses (C1, C4, C13, C14, C16) showed significantly higher heterosis value (>10%) over both mid parent and better parent. A similar kind of trend was also shown by the trait boll weight. Four crosses (C12, C14, C15, and C21) showed more than 10% heterosis over both mid and better parent value (Table. 8, Supplementary Table 2)

In the case of GOT(%) 9 cross combinations (C2, C5, C6, C7, C9, C10, C15, C22, C25) performed better in terms of heterosis over mid parent and 6 (C2, C5, C6, C9, C10, C15) crosses showed significantly higher positive heterosis of more than 10% over both mid and better parent. For 2.5% span length no cross combination showed any positive heterosis. The only cross C2 showed only positive heterosis over mid parent in terms of tenacity. In case of Micronaire value, crosses (C1, C2, C7, C16, C19, C26) showed significant negative heterosis over mid parent. For trait fibre fineness lowered micronaire is suitable for the trait improvement (Table. 9 and Supplementary Table 2). Twelve lines of *G. hirsutum* and five testers of *G. barbadense* were crossed in line x tester manners shown desirable heterosis for seed cotton yield along with other yield components in *G. barbadense* (Adsare et al., 2017). Samreen et al., (2008) also observed eighty four crosses obtained by crossing 12 lines with seven testers in line x tester fashion showed significant standard heterosis for most of the yield and fibre quality traits.

Discussion

The present study was done to identify the suitable parents and crosses for higher yield and fibre quality in desi cotton. Female parent CISA-2 showed the highest performance in terms of seed

cotton yield and bolls per plant whereas male parent RG-341 showed the highest performance in terms of boll weight. Whereas, the cross combinations which involved CISA-2 as female parent showed more than 10% heterosis in terms of SCY, boll weight and bolls per Plant. The crosses, C16 and C26 for SCY, C16 for bolls/ plant, C21 for boll weight showed more than 10% heterosis. On the other hand, the crosses involving DS-5 as female parent and HD-123, HD-450, RG-18 and LD-694 as male parents (C1, C2, C6, C15) showed significant positive heterosis in terms of SCY. Cluster analysis result also confirmed that the crosses C6 and C26 grouped under Cluster III had the highest average SCY whereas C1, C16, C15 were under Cluster-I having second highest seed cotton yield for the cluster of yield attributing traits (Fig. 1). For Boll/ plant, the crosses involving HD-123, RG-284, DLSA-24, DLSA-9 as male and DS-5 as female (C1, C4, C13, C14) showed >10% positive heterosis and also clustered under Cluster-I (fig. 1) having a highest average value of bolls per plant. In the case of boll weight, C12, C14, C15 grouped under Cluster-I having highest boll wt. also showed more than 10% heterosis over both mid parent and a better parent.

In terms of fibre quality traits HD-123 showed better performance for GOT(%), whereas DLSA-24 showed its best performance for 2.5% span length and tenacity traits. Interestingly heterosis result confirmed the crosses involving HD-123 could not show more than 10% heterosis in terms of GOT(%). But the crosses involving HD-400, RG-341, RG-18, CISA-59, CISA-64, CISA-65 and LD-694 as male parent with DS-5 as female parent showed more than 10% heterosis estimation for GOT% over both mid parent and better parent. These crosses (C2, C5, C6, C7, C9, C10, C15) can be used for further improvement of GOT(%). Cluster analysis for fibre quality also confirmed the similar trend that, for GOT% except for C7 the crosses with higher estimation (>10%) of heterosis were grouped in Cluster II (with highest GOT%) and in Cluster I (second highest average GOT%) (fig. 2). In case of Micronaire value, crosses (C1, C2, C7, C16, C19, C26) showed significant negative heterosis over mid parent of with C19 and C26 were grouped in Cluster III (fig. 2) with lowest micronaire value. For the trait tenacity the cross C2 (DS-5 x HD-400) only showed significant positive heterosis over mid parent value and also clustered under Cluster II (fig. 2) having highest average value of tenacity. Our result clearly showed that the identified crosses involving the parents can be used for the future breeding programme for development of the hybrids.

Conclusion

Among 30 cross combinations, SCA was positively significant for 10 crosses for seed cotton yield, 10 crosses for boll number, 10 crosses for boll weight, 9 crosses for GOT(%), 10 crosses for 2.5% span length and 8 crosses for fibre strength (gt/tex). Cluster III of yield attributing traits, consisted of 9 crosses (C3, C6, C18, C20, C26, C22, C23, C24, C30, and C8) showed the highest average seed cotton yield whereas Cluster II of fibre quality traits consisted of 3 crosses (C2, C12, C15) showed highest average GOT(%) with highest tenacity (g/tex). The identified crosses viz. DS-5 x HD 123 for Seed Cotton Yield and bolls/plant, DS-5 x DLSA 9 for boll weight, DS-5 x CISA 65 for GOT (%), CISA-2 x CISA 66 for micronaire (fibre fineness) showed significant estimation of heterosis in desirable direction and could be further utilized in the future breeding programme for specific trait improvement.

REFERENCES

- Adsare, A.D., Salve, A.N., Patil, N.P., 2017. Heterosis studies for quantitative traits in interspecific hybrids of cotton (*Gossypium hirsutum* L. x *Gossypium barbadense* L.). *J.of Phyto*, 9, 11-14.
- Ahuja, S.L., Dhayal, L.S., 2007. Combining ability estimates for yield and fibre quality traits in 4 x 13 line x tester crosses of *Gossypium hirsutum*. *Euphytica*. 153, 87-88.

- Ashok kumar, K., Ravikesavan, R., Prince, K. S. J., 2010. Combining ability estimates for yield and fibre quality traits in line x tester crosses of upland cotton (*Gossypium hirsutum*). *Inter. J. Bio.* 2(1),179.
- Karademir, C., Karademir, E., Ekinci, R., Gencer, O., 2009. Combining ability estimates and heterosis for yield and fiber quality of cotton in line x tester design. *Notulae Botanicae Horti Agrobotanici Cluj-Napoca* (in Romania). 37(2), 228-233.
- Kempthorne O.,1957. *An Introction to Genetic Statistics*. John Wiley and Sons Inc., New York,pp 73-78.
- Kempthorne, O., Curnow, R.N., 1961. The partial diallel cross. *Biometric*.17, 229-250.
- Kumar, A., Nirania, K.S., Chhavikant, B.A., 2017. Combining ability for seed cotton yield and attributing traits in American cotton (*Gossypium hirsutum* L.). *J.Pharmacog.Phytochem.* 6(6), 376-378.
- Mather, K., Jink, J.L., 1977. *Introduction to Biometrical Genetics: Chapter 3: Additive and Dominant Effects*. 1stEdn., Chapman and Hall Ltd., London,pp: 33-35.
- Mehetre S., 2015. Constraints of hybrid seed production in upland and cultivated diploid cottons: Will different male sterility systems rescue? A review. *J. Cotton Res. Dev.*29 (2), 181-211.
- Monicashree, C., AmalaBalu, P., Gunasekaran, M., 2017. Heterosis studies for yield and fibre quality traits in upland cotton (*Gossypium hirsutum* L.). *Int. J. Pure App. Biosci.* 5(3),169-186.
- Panse, V.G.,Sukhatme, P.V. 1967. *Statistical Methods of Agricultural Workers*. 2ndEdn., ICAR Publication, New Delhi, India, pp: 381.
- Samreen, K., Baloch, M.J., Soomro, Z.A., Kumbhar, M.B., Khan, N.U., Kumboh, N.,Veesar, N.F., 2008. Estimating combining ability through Line× Tester analysis in upland Cotton (*Gossypium hirsutum*). *Sarhad J. Agric.* 24(4), 581-586.
- Sheoran, O.P., Tonk, D.S., Kaushik, L.S., Hasija, R.C.,Pannu, R.S.,1998. *Statistical Software Package for Agricultural Research Workers*. In: *Recent Advances in information theory, Statistics & Computer Applications* by D.S. Hooda& R.C. Hasija. Department of Mathematics Statistics, Chaudhary Charan Singh Haryana Agricultural University, Hissar, Haryana 125 004, India, pp: 139-143.
- Srinivas, B., Bhadru, D., Rao, M. B., Gopinath, M., 2014. Combining ability studies for yield and fibre quality traits in upland cotton (*Gossypium hirsutum* L.). *SABRAO J. Breed. Genet.* 46(2), 18-23.
- Steel, R.G.D., Torrie, J.H., 1980. *Principles and Procedure of Statistics: A Biometric Approach*. 2ndEdn., McGraw Hill Book Co.Inc., New York, USA., ISBN-13: 9780070610286, pp:188-189.
- Tuteja, O.P., Verma, S.K., 2011. Effect of alien cytoplasm and nuclear genes on seed cotton yield and fibre quality traits in cotton (*Gossypium hirsutum*). *Indian J.Agric.Sci.*81, 314-20.
- Tuteja, O.P., Verma, S.K., Banga, M., 2013. Heterosis for seed cotton yield and other traits in GMS (Genetic male sterile) based hybrids of *G. hirsutum* L. *J. Cotton Res. Dev.*25 (1), 14-18.
- Verma S.K., Tuteja O.P., Ahuja S.L, Jal Singh, Koli N.R., Khadi B.M., Deshpande, L.A., Monga D., 2005. Identification of potential combiners and combinations from eco-geographical diverse genotypes of Asiatic cotton (*G. arboreum* L.).*Cotton Res. J.(J. Indian Soc. Cotton Improv.)*.30 (1), 39-46.
- Verma, S.K., Tuteja O.P., Ahuja S.L., 2017. Combining ability estimates for seed cotton yield and quality characters of parents and crosses based on genetic male sterility in Asiatic cotton (*Gossypium arboreum* L.). *Electronic J. Plant Breed.*8(4), 1046-1052.
- Verma, S.K., Tuteja, O.P., Monga, D., Waghmare, V.N. 2020. GMS-CISG 20 – A new genetic male sterile line of diploid cotton (*Gossypium arboreum* L.) with marker trait. *J. Cotton Res. Dev.*34(1), 46-49.
- Verma, S.K., Ahuja, S.L., Tuteja, O.P., Ram Parkash, Sunil Kumar, Mahendar Singh, Monga, D., 2004. Line x tester analysis of yield, its components and fibre quality traits in Cotton *Gossypium hirsutum* L.*J. Indian Soc. Cotton Improv.*29 (3), 151-157.
- Wynne, J.C., Emery, D.A., Rice, P.W., 1970. Combining ability estimates in *Arachis hypogaea* L. II. Field performance of F1 hybrids. *Crop Sci.*10, 713-715.

Table 1 Details of the crosses and their respective codes.

Crosses	Code	Crosses	Code	Crosses	Code
DS 5 x HD 123	C1	DS 5 x CISA 66	C11	CISA 2 x RG 18	C21
DS 5 x HD 400	C2	DS 5 x PAIG 8/3	C12	CISA 2 x CISA 59	C22
DS 5 x RG 270	C3	DS 5 x DLSA 24	C13	CISA 2 x CISA 60	C23
DS 5 x RG 286	C4	DS 5 x DLSA 9	C14	CISA 2 x CISA 64	C24
DS 5 x RG 341	C5	DS 5 x LD 694	C15	CISA 2 x CISA 65	C25
DS 5 x RG 18	C6	CISA 2 x HD 123	C16	CISA 2 x CISA 66	C26
DS 5 x CISA 59	C7	CISA 2 x HD 400	C17	CISA 2 x PAIG 8/3	C27
DS 5 x CISA 60	C8	CISA 2 x RG 270	C18	CISA 2 x DLSA 24	C28
DS 5 x CISA 64	C9	CISA 2 x RG 286	C19	CISA 2 x DLSA 9	C29
DS 5 x CISA 65	C10	CISA 2 x RG 341	C20	CISA 2 x LD 694	C30

Table 2 Analysis of Variance for Line x Tester mating design for various traits in *G. arboreum* L.

Source of Variation	DF	Seed Cotton Yield (kg/ha)	Bolls/Plant	Boll wt(g)	GOT (%)	2.5%Span length (cm)	MIC	Tenacity (g/tex)
Blocks	2	9,770.953	86.019	0.070	1.982	1.384	0.004	0.628
Parents	16	241,035.502**	31.468*	0.157**	7.706**	6.195**	0.890**	4.891**
Males	14	239,648.578**	29.371	0.177**	8.757**	6.902**	0.837**	4.851**
Female	1	62,201.553	73.500	0.000	0.375	0.060	0.540	1.042
Male vs Female	1	439,286.381	18.791	0.025	0.320	2.428	1.991	9.302
Crosses	29	282,756.126**	113.805**	0.253**	9.752**	7.295**	0.662**	3.877**
Parents vs. Crosses	1	137,023.199	49.785	0.841	191.239	89.424	0.051	37.511
Error	92	2,344.036	12.259	0.026	0.253	0.111	0.038	0.071
Total	140	12,428,712.123	5,153.447	13.183	624.582	413.108	22.151	236.032
σ^2_{gca}		642.389	2.172	-0.000	1.435	0.173	0.051	0.011
σ^2_{sca}		62,834.380	25.174	0.080	2.447	1.376	0.128	0.922
σ^2_A		1,284.778	4.343	-0.000	2.869	0.345	0.102	0.022
σ^2_D		62,834.380	25.174	0.080	2.447	1.376	0.128	0.922
$\sigma^2_{gca}/\sigma^2_{sca}$		0.010	0.086	0.000	0.586	0.126	0.398	0.012
$(\sigma^2_D/\sigma^2_A)^{1/2}$		48.907	5.796	0.000	0.853	3.988	1.255	41.909
Contribution of lines		67.13	61.30	45.92	32.86	68.32	54.11	63.25
Contribution of testers		0.26	3.94	3.79	28.98	3.33	14.26	1.07
Contribution of lines x testers		32.61	34.75	50.31	38.16	28.34	31.63	35.68

**Significant at 1% and 5% probability level of significant, DF: degree of freedom

Table 3 Estimates of general combining ability (GCA) effects for various traits in *G. arboreum* L.

Entry	SCY (kg/ha)	Bolls/Plant	Boll wt. (g)	GOT (%)	2.5% Span Length (cm)	MIC	Tenacity (g/tex)
Lines							
DS5	-15.50	-1.20	0.056	0.954**	-0.280*	0.174*	-0.116
CISA 2	15.50	1.20	-0.056	-0.954**	0.280*	-0.174*	0.116
SE±	5.267	0.267	0.017	0.064	0.041	0.024	0.033
Testers							
HD-123	446.43**	14.74**	0.217**	0.879**	-2.394**	0.166*	-1.590**
HD-400	-12.07	-4.19**	-0.267**	-0.004	-0.011	0.132	1.010**
RG-270	211.21**	0.33	-0.200**	-1.588**	1.256**	0.116	1.110**
RG-286	-65.77**	4.38**	0.050	0.229	1.939**	-0.501**	0.610**
RG-341	-26.16	-1.99*	-0.200**	-0.621**	-0.528**	0.216**	0.110**
RG-18	-36.76*	-0.99	0.000	1.546**	-1.778**	0.532**	-1.640**
CISA-59	146.64**	-0.56	0.133**	0.346	-1.744**	-0.234**	-0.473**
CISA-60	-157.71**	-1.56	-0.100*	0.079	-0.011	0.166*	0.643**
CISA-64	158.78**	-2.11**	-0.117*	0.312	-0.411**	0.032	-0.707**
CISA-65	114.89**	-2.07**	-0.117*	1.529**	-0.344**	0.566**	-0.573**
CISA-66	53.56**	-7.37**	-0.250**	-0.638**	0.006	-0.551**	0.543**
PAIG-8/3	-322.87**	-0.54	0.250**	1.212**	0.989**	-0.184**	0.843**
DLSA-24	-532.09**	2.71**	0.000	-1.688**	0.172	0.166*	-0.623**
DLSA-9	-298.64**	1.08	0.283**	-1.438**	0.672**	-0.051	-0.290**
LD-694	320.58**	-1.86*	0.317**	-0.154	2.189**	-0.568**	1.027**

SE±	19.706	0.999	0.062	0.239	0.155	0.088	0.124
------------	---------------	--------------	--------------	--------------	--------------	--------------	--------------

**Significant at 1% and 5% probability level of significant

Table 4 Estimates of specific combining ability (SCA) effects for various traits in *G. arboreum* L.

Crosses	SCY (kg/ha)	Bolls/ Plant	Boll wt. (g)	GOT (%)	2.5% Span Length (cm)	MIC	Tenacity (g/tex)
DS 5 x HD 123	-15.60	1.62**	-0.039	0.746**	-0.037	-0.208**	-1.001**
DS 5 x HD 400	177.33**	-3.08**	0.011	1.129**	1.180**	-0.441**	1.166**
DS 5 x RG 270	35.68**	0.00	-0.022	0.312	-0.220*	0.009	-0.734**
DS 5 x RG 286	113.07**	5.62**	0.228**	0.162	-0.470**	0.426**	-0.734**
DS 5 x RG 341	-109.72**	-1.68**	-0.056	2.312**	0.430**	0.009	-0.968**
DS 5 x RG 18	192.52**	1.02	-0.222**	-0.288	0.713**	-0.174**	0.049
DS 5 x CISA 59	12.08	-0.88	0.144**	-1.221**	0.647**	-0.141**	1.082**
DS 5 x CISA 60	-347.27**	-2.68**	-0.156**	-0.588**	-0.953**	-0.074	-0.101
DS 5 x CISA 64	-36.95**	-1.56*	-0.239**	0.312	-1.620**	-0.008	0.016
DS 5 x CISA 65	-20.30	-2.53**	-0.406**	-0.404**	0.780**	-0.108	0.782**
DS 5 x CISA 66	-388.87**	-9.06**	-0.106**	-2.204**	-1.070**	0.642**	0.232**
DS 5 x PAIG 8/3	166.50**	3.27**	0.261**	-0.288	0.713**	-0.158**	0.532**
DS 5 x DLSA 24	14.78	2.82**	0.078	-1.321**	-1.003**	-0.141**	-0.368**
DS 5 x DLSA 9	221.20**	4.09**	0.361**	-0.004	0.430**	0.209**	0.166
DS 5 x LD 694	-14.45	3.0588	0.161**	1.346**	0.480**	0.159**	-0.118
CISA 2 x HD 123	15.60	-1.62**	0.039	-0.746**	0.037	0.208**	1.001**
CISA 2 x HD 400	-177.33**	3.08**	-0.011	-1.129**	-1.180**	0.441**	-1.166**
CISA 2 x RG 270	-35.68**	0.00	0.022	-0.312	0.220*	-0.009	0.734**
CISA 2 x RG 286	-113.07**	-5.62**	-0.228**	-0.162	0.470**	-0.426**	0.734**
CISA 2 x RG 341	109.72**	1.68**	0.056	-2.312**	-0.430**	-0.009	0.968**
CISA 2 x RG 18	-192.52**	-1.02	0.222**	0.288	-0.713**	0.174**	-0.049
CISA 2 x CISA 59	-12.08	0.88	-0.144**	1.221**	-0.647**	0.141**	-1.082**
CISA 2 x CISA 60	347.27**	2.68**	0.156**	0.588**	0.953**	0.074	0.101
CISA 2 x CISA 64	36.95**	1.56*	0.239**	-0.312	1.620**	0.008	-0.016
CISA 2 x CISA 65	20.30	2.53**	0.406**	0.404**	-0.780**	0.108	-0.782**
CISA 2 x CISA 66	388.87**	9.06**	0.106**	2.204**	1.070**	-0.642**	-0.232**
CISA 2 x PAIG 8/3	-166.50**	-3.27**	-0.261**	0.288	-0.713**	0.158**	-0.532**
CISA 2 x DLSA 24	-14.78	-2.82**	-0.078	1.321**	1.003**	0.141**	0.368**
CISA 2 x DLSA 9	-221.20**	-4.09**	-0.361**	0.004	-0.430**	-0.209**	-0.166
CISA 2 x LD 694	14.45	-3.05**	-0.161**	-1.346**	-0.480**	-0.159**	0.118
SE±	19.706	0.999	0.062	0.239	0.155	0.088	0.124

**Significant at 1% and 5% probability level of significant

Table 5 Mean Performance of Parents (males and females)

Entry	SCY (kg/ha)	Bolls/ Plant	Boll wt (g)	GOT (%)	2.5%Span Length (cm)	MIC	Tenacity (g/tex)
DS5	1,711.53	36.17	2.30	36.20	24.10	6.40	19.40
CISA 2	1,915.17	43.17	2.30	35.70	24.30	5.80	20.23
HD-123	1,517.90	38.73	2.17	39.67	20.70	8.20	16.17
HD-400	1,146.73	30.30	2.40	36.00	20.30	6.80	18.80
RG-270	1,700.53	36.10	2.20	34.70	23.50	7.10	16.60
RG-286	1,833.73	36.33	2.37	36.10	24.70	6.50	18.13
RG-341	1,733.03	39.90	3.00	36.70	24.10	7.17	17.33
RG-18	1,147.07	41.50	1.93	35.60	22.50	6.43	17.63
CISA-59	1,777.67	35.80	2.67	32.10	22.60	6.73	19.73
CISA-60	1,765.57	38.50	2.47	36.27	23.50	6.60	18.70
CISA-64	1,747.77	39.27	2.43	35.20	25.40	6.70	19.80
CISA-65	1,500.73	37.57	2.47	33.60	23.50	6.77	18.73

CISA-66	1,788.63	37.40	2.40	35.70	24.53	6.70	17.93
PAIG-8/3	1,128.60	41.03	2.20	37.50	23.40	6.53	17.83
DLSA-24	1,244.13	34.97	2.23	34.50	25.70	6.20	20.33
DLSA-9	1,136.47	36.17	2.30	36.20	24.10	6.47	19.40
LD-694	1,710.93	43.17	2.30	35.70	24.30	5.80	20.23
Mean	1,559.19	38.00	2.36	35.73	23.60	6.64	18.65
C.D.	77.479	3.814	0.175	0.228	0.152	0.197	0.248
SE(m)	26.775	1.318	0.060	0.079	0.052	0.068	0.086
C.V.	2.974	6.007	4.435	0.382	0.385	1.776	0.795
Range	1128.60-1915.17	30.30-43.17	1.93-3.00	32.10-39.67	20.30-25.70	5.80-8.20	16.17-20.33

Table 6 Cluster analysis for yield attributing traits

Cluster no.	No. of Crosses	Cluster colour	SCY (kg/ha)			Boll no.			Boll weight.		
			Mean	SD	Range	Mean	SD	Range	Mean	SD	Range
1	8		1779.65	231.10	1452.23-2101.63	44.59	6.67	36.60-51.40	2.59	0.19	2.40-2.90
2	7		1552.07	185.55	1273.3-1773.87	33.30	6.01	21.6-39.33	1.91	0.09	1.73-2.00
3	9		1850.39	112.05	1723.17 - 2082.03	39.69	2.05	35.53-42.13	2.10	0.13	1.97-2.3
4	6		1161.33	123.93	1091.30-1410.33	38.37	3.34	33.80-43.57	2.16	0.15	2.00-2.37

Table 7 Cluster analysis for fibre quality traits

Cluster no.	No. of Crosses	Cluster Colour	GOT (%)			2.5% span Length			Mic			Tenacity (g/tex)		
			Mean	SD	Range	Mean	SD	Range	Mean	SD	Range	Mean	SD	Range
1	8		39.85	0.80	38.77-40.8	20.47	1.03	19.23-22.1	6.93	0.30	6.33-7.23	16.28	0.80	14.87-17.67
2	3		40.19	0.14	40.03-40.3	23.51	0.76	22.83-24.33	6.42	0.05	6.37-6.47	18.94	0.64	18.37-19.63
3	3		37.24	1.54	35.7-38.77	23.95	0.67	23.3-24.63	5.48	0.24	5.23-5.7	18.62	0.55	18-19.03
4	16		37.09	1.40	34.27-39.5	22.01	1.27	19.87-23.7	6.68	0.23	6.17-7	17.77	0.76	16.47-19.53

UNDER PEER REVIEW

Table 8 Estimation of Heterosis over mid parent and better parent (>10%) yield attributing traits

SCY (kg/ha)	Bolls/ Plant	Boll wt. (g)
(MP, BP)	(MP, BP)	(MP, BP)
C1 (26.30**, 19.16**)	C1 (45.26**, 40.45**)	C1 (8.96**, 5.80**)
C2 (24.12**, 3.64**)	C3 (6.18**, 6.08**)	C4 (8.57**, 7.04**)
C3 (8.76**, 8.41**)	C4 (32.51**, 32.20**)	C12 (22.963, 20.29**)
C6 (23.44**, 3.09**)	C13 (22.49**, 20.46**)	C13 (2.941, 1.45)
C15 (11.82**, 11.87**)	C14 (19.45**, 19.45**)	C14 (26.087, 26.09**)
C16 (22.44**, 9.74**)	C16 (30.81**, 24.09**)	C15 (18.841, 18.84**)
C26 (12.43**, 8.71**)		C16 (7.463, 4.35**)
C30 (8.91**, 3.11**)		C21 (11.811, 2.90**)

Table 9 Estimation of Heterosis over mid parent and better parent for fibre quality traits

GOT (%)	MIC
(MP, BP)	(MP, BP)
C1 (7.38**, 2.69**)	C4 (3.88**, 3.08**)
C2 (11.45**, 11.14**)	C6 (11.17**, 10.88**)
C3 (6.72**, 4.51**)	C8 (5.64**, 4.04**)
C4 (9.27**, 9.12**)	C9 (3.82**, 1.49)
C5 (11.93**, 11.17**)	C10 (9.87**, 6.90**)
C6 (12.44**, 11.51**)	C11 (4.84**, 2.49**)
C7 (11.96**, 5.62**)	C13 (7.94**, 6.25**)
C8 (6.53**, 6.43**)	C14 (7.77**, 7.22**)
C9 (11.30**, 9.76**)	C17 (11.11**, 2.94**)
C10 (15.28**, 11.14**)	C21 (16.62**, 10.88**)
C12 (8.64**, 6.76**)	C23 (7.53**, 1.01)
C14 (4.05**, 4.05**)	C25 (13.00**, 4.93**)
C15 (12.10**, 11.33**)	C28 (12.22**, 8.60**)
C19 (3.81**, 3.23**)	Tenacity (g/tex)
C21 (9.49**, 9.34**)	C2 (2.79**, 1.20)
C22 (14.36**, 8.59**)	
C23 (5.23**, 4.41**)	
C24 (4.94**, 4.20**)	
C25 (12.94**, 9.62**)	
C26 (8.59**, 8.59**)	
C27 (5.74**, 3.20**)	
C28 (4.94**, 3.18**)	

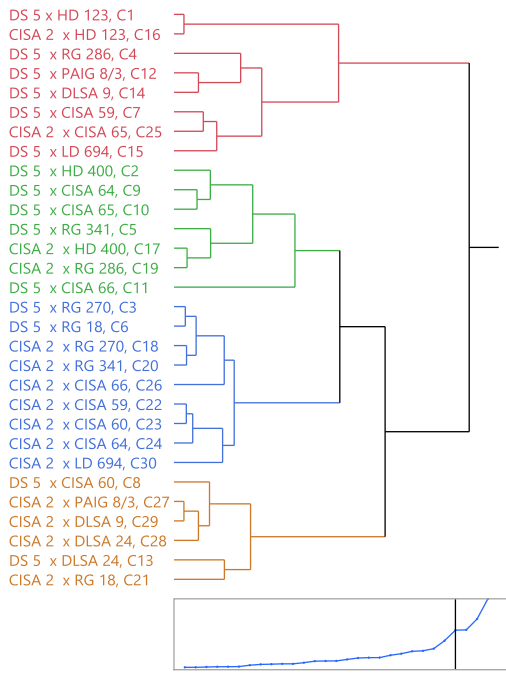

Figure 1. Cluster analysis of the crosses for yield attributing traits involving thirty cross combinations

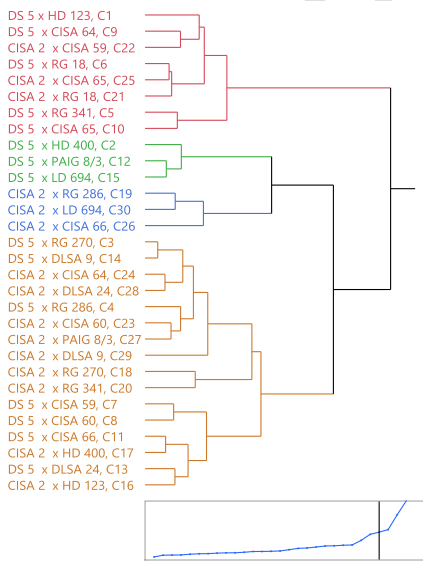

Figure 2. Cluster analysis of the crosses for fibre quality traits involving thirty cross combinations

UNDER PEER REVIEW

Supplementary table 1: Mean Performance of Crosses

Crosses	SCY (Kg/ha)	Plant ht (cm)	Mono pods	Sym pods	Bolls/ Plant	Boll wt (g)	GOT (%)	2.5%Span length(cm)	MIC	Tenacity (g/tex)
DS 5 x HD 123	2,039.43	168.30	4.57	22.47	54.40	2.43	40.73	19.23	6.73	14.87
DS 5 x HD 400	1,773.87	189.83	4.63	13.73	30.77	2.00	40.23	22.83	6.47	19.63
DS 5 x RG 270	1,855.50	168.37	3.93	14.87	38.37	2.03	37.83	22.70	6.90	17.83
DS 5 x RG 286	1,655.90	206.87	4.20	19.03	48.03	2.53	39.50	23.13	6.70	17.33
DS 5 x RG 341	1,472.73	213.90	4.80	14.40	34.37	2.00	40.80	21.57	7.00	16.60
DS 5 x RG 18	1,764.37	218.17	4.13	17.93	38.07	2.03	40.37	20.60	7.13	15.87
DS 5 x CISA 59	1,767.33	158.57	3.43	15.53	36.60	2.53	38.23	20.57	6.40	18.07
DS 5 x CISA 60	1,103.63	218.00	4.13	11.63	33.80	2.00	38.60	20.70	6.87	18.00
DS 5 x CISA 64	1,730.43	215.67	4.67	15.13	34.37	1.90	39.73	19.63	6.80	16.77
DS 5 x CISA 65	1,703.20	180.03	3.60	15.60	33.43	1.73	40.23	22.10	7.23	17.67
DS 5 x CISA 66	1,273.30	118.67	3.43	8.83	21.60	1.90	36.27	20.60	6.87	18.23
DS 5 x PAIG 8/3	1,452.23	196.20	4.03	13.07	40.77	2.77	40.03	23.37	6.43	18.83
DS 5 x DLSA 24	1,091.30	180.67	3.27	14.63	43.57	2.33	36.10	20.83	6.80	16.47
DS 5 x DLSA 9	1,531.17	166.33	3.50	20.87	43.20	2.90	37.67	22.77	6.93	17.33
DS 5 x LD 694	1,914.73	218.23	3.60	15.43	39.23	2.73	40.30	24.33	6.37	18.37
CISA 2 x HD 123	2,101.63	217.27	4.73	12.10	53.57	2.40	37.33	19.87	6.80	17.10
CISA 2 x HD 400	1,450.20	224.73	4.77	15.57	39.33	1.87	36.07	21.03	7.00	17.53
CISA 2 x RG 270	1,815.13	199.90	4.63	15.53	40.77	1.97	35.30	23.70	6.53	19.53
CISA 2 x RG 286	1,460.77	216.13	4.20	13.87	39.20	1.97	37.27	24.63	5.50	19.03
CISA 2 x RG 341	1,723.17	207.40	4.23	12.87	40.13	2.00	34.27	21.27	6.63	18.77
CISA 2 x RG 18	1,410.33	178.83	4.30	12.33	38.43	2.37	39.03	19.73	7.13	16.00
CISA 2 x CISA 59	1,774.17	224.40	4.47	16.67	40.77	2.13	38.77	19.83	6.33	16.13
CISA 2 x CISA 60	1,829.17	203.23	4.73	14.53	41.57	2.20	37.87	23.17	6.67	18.43
CISA 2 x CISA 64	1,835.33	193.80	4.77	10.20	39.90	2.27	37.20	23.43	6.47	16.97
CISA 2 x CISA 65	1,774.80	198.00	4.73	11.73	40.90	2.43	39.13	21.10	7.10	16.33
CISA 2 x CISA 66	2,082.03	199.70	3.23	11.30	42.13	2.00	38.77	23.30	5.23	18.00
CISA 2 x PAIG 8/3	1,150.23	203.17	4.33	13.43	36.63	2.13	38.70	22.50	6.40	18.00
CISA 2 x DLSA 24	1,092.73	222.80	4.13	12.27	40.33	2.07	36.83	23.40	6.73	17.43
CISA 2 x DLSA 9	1,119.77	215.00	4.57	13.97	37.43	2.07	35.77	22.47	6.17	17.23
CISA 2 x LD 694	1,974.63	199.67	4.00	12.83	35.53	2.30	35.70	23.93	5.70	18.83
C.D.	81.86	25.31	1.04	1.77	4.15	0.259	0.992	0.645	0.367	0.516
SE(m)	28.842	8.917	0.368	0.623	1.462	0.091	0.349	0.227	0.129	0.182
C.V.	3.076	7.824	15.184	7.486	6.451	7.177	1.586	1.793	3.390	1.791

Supplementary table 2: Estimation of Heterosis over mid parent and better parent for seed cotton yield and fibre quality traits.

******, *Significant at 1% and 5% probability level of significance. MP- Heterosis over mid parent, BP- Heterobeltiosis or Heterosis over better parent

Crosses	SCY (Kg/ha)		Plant ht. (cm)		Monopods		Sympods		Bolls/Plant		Boll wt. (g)		GOT (%)		2.5%Span length (cm)		MIC		Tenacity (g/tex)	
	MP	BP	MP	BP	MP	BP	MP	BP	MP	BP	MP	BP	MP	BP	MP	BP	MP	BP	MP	BP
DS 5 x HD 123	26.30**	19.16**	1.071	-3.42**	45.75**	44.21**	79.02**	70.63**	45.26**	40.45**	8.96**	5.80**	7.38**	2.69**	-14.14**	-20.19**	-7.76**	-17.89**	-16.40**	-23.37**
DS 5 x HD 400	24.12**	3.64**	26.49**	8.93**	40.40**	32.38**	1.85	-0.483	-7.42**	-14.93**	-14.89**	-16.67**	11.45**	11.14**	2.85**	-5.26**	-2.02	-4.90**	2.79**	1.20
DS 5 x RG 270	8.76**	8.41**	-2.32*	-3.39**	33.33**	26.88**	20.22**	12.91**	6.18**	6.08**	-9.63**	-11.59**	6.72**	4.51**	-4.62**	-5.81**	2.22**	-2.82**	-0.93	-8.08**
DS 5 x RG 286	-6.59**	-9.70**	19.32**	18.71**	35.48**	35.49**	50.26**	44.56**	32.51**	32.20**	8.57**	7.04**	9.27**	9.12**	-5.19**	-6.34**	3.88**	3.08**	-7.64**	-10.65**
DS 5 x RG 341	-14.49**	-15.02**	25.61**	22.74**	47.69**	41.18**	16.29**	9.37**	-9.64**	-13.87**	-24.53**	-33.33**	11.93**	11.17**	-10.51**	-10.51**	3.19**	-2.33*	-9.62**	-14.43**
DS 5 x RG 18	23.44**	3.09**	17.84**	11.31**	5.98**	-12.06**	31.70**	27.49**	-1.974	-8.27**	-3.94**	-11.59**	12.44**	11.51**	-11.59**	-14.52**	11.17**	10.88**	-14.31**	-18.21**
DS 5 x CISA 59	1.30	-0.58	-2.90**	-9.01**	6.74**	3.00**	20.41**	17.98**	1.71	1.20	2.01	-5.00**	11.96**	5.62**	-11.92**	-14.66**	-2.54**	-4.95**	-7.67**	-8.45**
DS 5 x CISA 60	-36.52**	-37.49**	24.95**	24.81**	35.52**	33.33**	-11.08**	-11.65**	-9.46**	-12.21**	-16.08**	-18.92**	6.53**	6.43**	-13.03**	-14.11**	5.64**	4.04**	-5.51**	-7.22**
DS 5 x CISA 64	0.05	-0.99	28.28**	23.76**	60.00**	50.54**	10.19**	5.83**	-8.88**	-12.48**	-19.718	-21.92**	11.30**	9.76**	-20.67**	-22.70**	3.82**	1.49	-14.46**	-15.32**
DS 5 x CISA 65	6.04**	-0.49	35.16**	3.31**	-27.27**	-47.059	31.28**	18.48**	-9.31**	-11.00**	-27.273	-29.73**	15.28**	11.14**	-7.14**	-8.30**	9.87**	6.90**	-7.34**	-8.94**
DS 5 x CISA 66	-27.24**	-28.81**	-32.10**	-32.29**	8.42**	6.19**	-29.14**	-32.91**	-41.28**	-42.25**	-19.149	-20.83**	0.88	0.18	-15.28**	-16.03**	4.84**	2.49**	-2.32**	-6.01**
DS 5 x PAIG 8/3	2.27*	-15.15**	6.70**	1.40	12.04**	-1.63	2.89**	-0.76	5.61**	-0.65	22.963	20.29**	8.64**	6.76**	-1.61	-3.043	-0.52	-1.53**	1.16**	-2.92**
DS 5 x DLSA 24	-26.16**	-36.24**	3.88**	3.67**	6.52**	5.38**	23.84**	11.14**	22.49**	20.46**	2.941	1.45	2.12*	-0.28	-16.33**	-18.94**	7.94**	6.25**	-17.11**	-19.02**
DS 5 x DLSA 9	7.53**	-10.54**	-4.55**	-4.55**	12.90**	12.90**	58.48**	58.48**	19.45**	19.45**	26.087	26.09**	4.05**	4.05**	-5.53**	-5.53**	7.77**	7.22**	-10.65**	-10.65**
DS 5 x LD 694	11.82**	11.87**	20.85**	16.77**	16.13**	16.13**	15.32**	13.48**	-1.09	-9.11**	18.841	18.84**	12.10**	11.33**	0.55	0.14	4.37**	-0.52	-7.32**	-9.23**
CISA 2 x HD 123	22.44**	9.74**	25.71**	16.25**	51.06**	49.47**	-5.22**	-11.03**	30.81**	24.09**	7.463	4.35**	-0.93	-5.88**	-11.70**	-18.24**	-2.86**	-17.07**	-6.04**	-15.49**
CISA 2 x HD 400	-5.28**	-24.28**	43.69**	20.24**	44.44**	36.19**	13.63**	12.80**	7.08**	-8.88**	-20.567	-22.22**	0.60	0.19	-5.68**	-13.44**	11.11**	2.94**	-10.16**	-13.34**
CISA 2 x RG 270	0.40	-5.22**	11.87**	6.96**	57.06**	49.46**	23.44**	14.22**	2.86**	-5.56**	-12.593	-14.49**	0.28	-1.12	-0.84	-2.47*	1.29	-7.98**	6.06**	-3.46**
CISA 2 x RG 286	-22.07**	-23.73**	20.29**	15.64**	35.48**	35.48**	7.63**	1.96**	-1.38	-9.19**	-15.714	-16.90**	3.81**	3.23**	0.54	-0.27	-10.57**	-15.39**	-0.78	-5.93**
CISA 2 x RG 341	-5.53**	-10.03**	17.44**	10.97**	30.26**	24.51**	2.12*	-5.39**	-3.37**	-7.03**	-24.528	-33.33**	-5.34**	-6.63**	-12.12**	-12.48**	2.31*	-7.44**	-0.09**	-7.25**
CISA 2 x RG 18	-7.89**	-26.36**	-6.59**	-8.76**	10.26**	-8.51**	-10.84**	-12.32**	-9.213	-10.97**	11.811	2.90**	9.49**	9.34**	-15.67**	-18.79**	16.62**	10.88**	-15.49**	-20.92**
CISA 2 x CISA 59	-3.93**	-7.36**	32.30**	20.06**	38.86**	34.00**	27.07**	22.55**	3.25**	-5.56**	-14.094	-20.00**	14.36**	8.59**	-15.42**	-18.38**	1.06	-5.94**	-19.27**	-20.26**
CISA 2 x CISA 60	-0.61	-4.49**	12.42**	8.74**	55.19**	52.69**	9.27**	6.86**	1.80	-3.71**	-7.692	-10.81**	5.23**	4.41**	-3.07**	-4.66**	7.53**	1.01	-5.31**	-8.90**
CISA 2 x CISA 64	0.21	-4.17**	11.10**	3.69**	63.43**	53.76**	-26.88**	-28.67**	-3.20**	-7.57**	-4.225	-6.85**	4.94**	4.20**	-5.70**	-7.74**	3.47**	-3.48**	-15.27**	-16.15**
CISA 2 x CISA 65	3.91**	-7.33**	41.92**	5.94**	-4.38**	-30.39**	-3.03**	-13.73**	1.32	-5.25**	2.10*	-1.35	12.94**	9.62**	-11.72**	-13.17**	13.00**	4.93**	-16.17**	-19.28**
CISA 2 x CISA 66	12.43**	8.71**	10.28**	6.85**	2.11*	-0.000	-10.91**	-16.91**	4.59**	-2.39*	-14.89**	-16.67**	8.59**	8.59**	-4.57**	-5.03**	-16.27**	-21.89**	-5.68**	-11.04**
CISA 2 x PAIG 8/3	-24.42**	-39.94**	6.82**	5.00**	20.37**	5.69**	4.00**	-1.23	-12.99**	-15.14**	-5.18**	-7.25**	5.74**	3.20**	-5.66**	-7.41**	3.78**	-2.04	-5.43**	-11.04**
CISA 2 x DLSA 24	-30.82**	-42.94**	23.62**	19.21**	34.78**	33.33**	1.94	-9.80**	3.24**	-6.56**	-8.82**	-10.15**	4.94**	3.18**	-6.40**	-8.95**	12.22**	8.60**	-14.05**	-14.26**
CISA 2 x DLSA 9	-26.61**	-41.53**	19.06**	15.04**	47.31**	47.31**	4.36**	2.70*	-5.63**	-13.28**	-10.15**	-10.15**	-0.51	-1.20	-7.16**	-7.55**	0.54	-4.64**	-13.04**	-14.83**
CISA 2 x LD 694	8.91**	3.11**	6.83**	6.83**	29.03**	29.03**	-5.64**	-5.64**	-17.68**	-17.68**	0.00	0.00	-0.00	-0.00	-1.51	-1.51	-1.72	-1.72	-6.92**	-6.92**

UNDER PEER REVIEW