

ANALYSIS AND STUDY OF SEISMIC RESPONSE OF A G+13 MULTISTORIED BUILDING FOR DIFFERENT TYPES OF DAMPERS USING ETABS SOFTWARE

ABSTRACT

Vibration refers to repeated movements that cause fatigue and decreased function of the structure. An earthquake can emit large amounts of energy that can have a detrimental effect on all parts of a building. Therefore, the reduction of vibration or maintenance of buildings such as bridges, dams, roads and buildings is important for the safety of life and the reduction of economic losses. Different types of dampers are currently being developed to reduce vibration in those structures. One of the solutions to reduce vibration vibrations in a building is to use vibration control devices such as dampers and base isolators. The purpose of this study was to investigate the best earthquake response for different types of base isolators and dampers. A 13 storey building is modelled and responses of Storey displacement, story drifts and overturning moments were determined and compared using ETABS software.

I. Introduction

With rapid economic development and advanced technology, public buildings such as high-rise buildings, towers and long bridges are designed with greater flexibility, leading to an increase in their tendency to the external future. Therefore, these flexible structures are vulnerable to exposure to high levels of vibration under strong winds or earthquakes. Earthquake loads should be carefully modeled to assess the actual behavior of the structure with a clear understanding that damage is expected but should be controlled. It has finally forced engineers and scientists to come up with new ideas and ways to save buildings and structures from destructive earthquakes.

Two basic technologies are used to protect buildings from the destructive effects of earthquakes. They are Base isolation devices and seismic dampers. The concept of subdivision is to subdivide the building into such a way that seismic movements can be transferred across the structure, or at least significantly reduced. Seismic dampers are special tools introduced into the building to absorb the energy provided by ground movement in the building (similar to how shock absorbers in vehicles absorb impact due to road flexibility).

The basis for the concept of isolation was introduced by engineers and scientists in early 1923 and thereafter developed a variety of methods to distinguish buildings and structures from earthquakes around the world. Countries like the USA, New Zealand, Italy Japan, China and European countries have used these techniques as their common practice in many public buildings and residential buildings. Hundreds of buildings are built each year in a system of segregation and foundation in these countries. To date, in India, the use of base isolating methods in public or residential buildings has begun with the exception of a few buildings is in its inception and except few buildings. After the 1993 Killari (Maharashtra) earthquake, the first model is demonstrated in India. Two single-storey buildings (one school building and another shopping mall) in the recently relocated town of Killari are constructed of rubber isolators mounted on a sturdy surface.

1.1 Friction pendulum bearing system

Friction pendulum bearings (FPBs) is a modern slide-based earthquake protection system and has been emerging steadily and in importance over the past decade. The first official model was designed by Victor Zayas in 1985, and FBS is now the best security system in the world today. Today, FPBs are available in a variety of configurations, including single, double, and triple concave systems. It consists of a load-bearing bottom plate covered with a slide (Teflon). The building that sits on the top plate also moves until

the quake work stops, and then the area returns to its original position, i.e. in the middle of the concave area. During this process, most earthquakes are dispersed; thus preventing future damage and the structure remains the same vertical axis throughout the earthquake event.

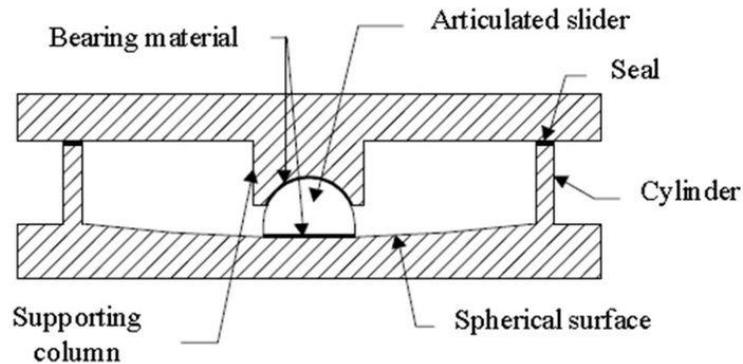
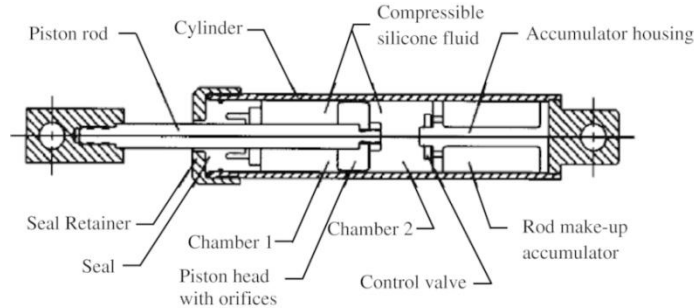

Figure 8: Friction Pendulum Bearings

1.2 Fluid Viscous dampers (FVD):

Fluid viscous damping is a method of adding energy dissipation to the lateral system of a building structure. The fluid viscous damper dissipates energy by pushing liquids from the orifice, producing water-repellent pressure creating force. This power dissipates 90 degrees outside the phase and the power is driven away from the structure. This means that mitigation forces do not significantly increase earthquake loads with a comparable degree of structural damage.



(a) Schematic diagram of fluid viscous damper (Symans and Constantinou, 1998)

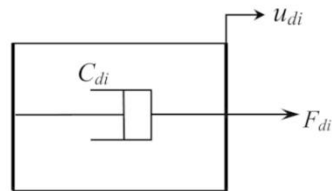

(b) Mathematical model of fluid viscous damper

Figure 9: Schematic diagram and mathematical model of Fluid Viscous damper

The force generated in each viscous damper is characterized by the following constitutive expression:

$$F=CV^\alpha$$

Where F= total output force provided by the damper

C= damping coefficient

V = relative velocity between the ends of the damper

α = damping exponent (characteristic value of the fluid viscosity), value can vary between 0.1 to 2 (Guerreiro, 2006).

1.3 Viscoelastic Damper (VED):

The VE damper uses a polymeric material, which dissipates shear deformation while loaded and the major mechanical properties are functions of frequency and ambient temperatures. This damper has plates in between polymer filled elements has molecules connected together like a chain. As a result of the cellular network, viscoelastic materials show a high degree of resistance to modification. In fact, the durability of the building systems will be enhanced by the use of this material in the structure which is usually applied to bracing. On the other hand, when deformation is applied to this material, some of the molecular bonds are broken and heat is produced, depending on the temperature and loading frequency. Therefore, some forces are used to break the bonds, and they are wasted. Immersion of these substances is caused by friction or collapse of the intermolecular bond. After loading over time, the material returns to its original strength, which is the amount of this return depends on the material temperature, the recurring frequency and the size of the strain. In short, by installing this material, stiffness and damping in the structural elements are increased. The installation of dampers should not be limited to braces, but can be used with special arrangements throughout the building where shear deformation occurs.

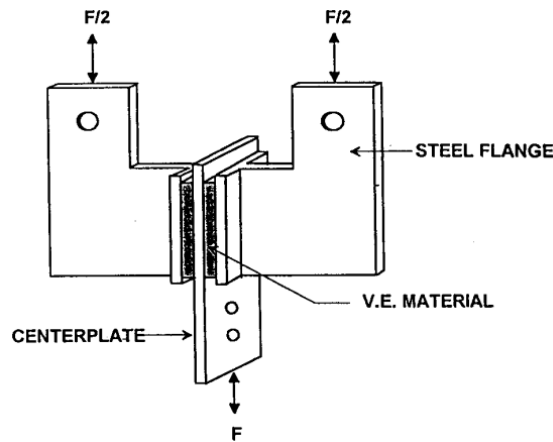

Figure 10: Layout of Viscoelastic Damper

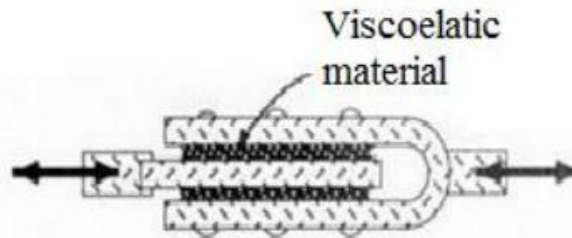

Figure 11: Visco Elastic Damper

$$k_d = AG'/t \dots \dots \dots (1)$$

$$C_d = AG''/ \omega t \dots \dots \dots (2)$$

$$G' = 16.0 \omega^{0.51} \gamma^{-0.23} e^{(72.46/\text{Temperature})}$$

$$G'' = 18.5\omega^{0.51} \gamma^{-0.20e} (73.89/\text{Temperature})$$

In which

A = area of the damper ,

t = thickness of one layer of visco-elastic material,

ω = natural frequency of the structure,

kd = stiffness of damper ,

Cd = damping co-efficient,

G' = shear storage modulus and G'' = shear loss modulus.

1.4 Lead rubber bearing (LRB):

Lead Rubber Bearing (LRB) is a laminated rubber bearing that contains one or more lead plugs to deflect in shear. Lead loading is physically enabling to a 10 MPa flow stress, which provides dual response. For that reason the lead should fit snugly on the elastomeric bearing, and this is achieved by making the lead plug slightly larger than the hole and using force when inserting it into the hole. The main purpose of the foundation division is to modify the structural response so that the soil can move under the structure without passing these movements to the structure. In the proper system these separations would be complete. A completely solid building will have a zero period. When the ground moves the acceleration caused to the building will be equal to the acceleration of the ground and there will be a slight zero movement between the building and the ground. The building and the ground movement is in same amount.

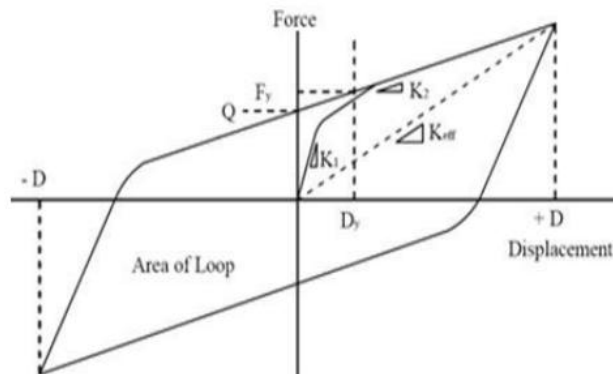

Figure 12 : Parameters Basic Hysteresis Loop of head of Lead rubber Bearing

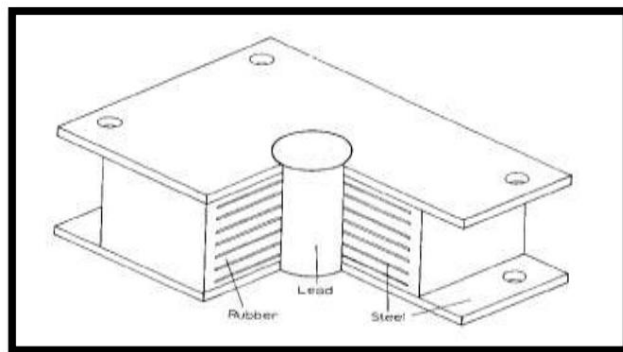

Figure 12: Lead Rubber Bearing

For designing the base isolator following data should be input in ETABS.

Rotational Inertia1	0.2180	kN/m
For U1 Effective Stiffness	1316191.49	kN/m
For U2 & U3 Effective Stiffness	4013.432	kN-m
For U2 & U3 Efficient Damping	0.05	Percent
For U2 and U3 distance from end-J	0.0032	M
For U2 & U3 Stiffness	36981.77	kN/m
For U2 & U3 Yield Strength	145.203	k

OBJECTIVES OF THE STUDY:

- Normal seismic modelling and analysis of RCC structure with dampers and fixed base.
- Study and compare the base isolators and types of damper systems and their effect on structures.
- To check the results and conclude for the better and safer structure in severe seismic zone.

LITERATURE REVIEW:

Dhiraj, Dr. Prof. Pravat, “Base Isolation of Residential Building using Lead Rubber Bearing Technique”, analysed the structures of G+10, G+15 storeys building in seismic zone II. The models are analysed with and without base isolators to investigate the effectiveness of isolator. This study provides a comparative results of the analysis with varied number of storeys following equivalent static method in ETABS software. Design of base isolator was performed to find the stiffness and physical dimension of the core of LRB to be given at the base of structures.

Naziya Ghanchi, Shilpa Kewate, “Dynamic analysis of 25 storey RCC building with and without viscous dampers”, The use of passive dampers to improve seismic performance and improved construction of new buildings has increased in recent years. The main objective of the study was to evaluate the improvement in the response achieved with the use of viscous materials. Energy caused by a strong earthquake will affect the structure. Review of the Response spectrum of the 25-storey RCC building to be used as a commercial building, with a concrete wall and a floor area of 735 sq. m in zone III. Results are concluded as, by adding viscous dampers in the reaction of the building structure is reduced by a significant value.

Puneeth , Praveen,” Study on the effect of viscous damper for RCC frame structure”, A symmetrical plan of 8-storey reinforced concrete structure is considered. The damper-free structure is modeled and analyzed in ETABS 2015. In this study, viscous dampers are used to reduce the seismic impact of a structure under an earthquake load. Frames (with viscous damper and outer) are arranged according to the structural properties described in the work. The seismic behavior of the reinforced concrete structure was judged by looking at parameters such as displacement, drift and base shear.

II. METHODOLOGY

The research is based on analysis of five building models with different dampers systems and bearing. These were designed for all supports at base by considering the maximum gravity load coming on column at the base and were used for further analysis. The building models considered for research are as follows.

Model 1: regular RC building with fixed base

Model 2: regular RC building with FPD

Model 3: regular building with FVD

Model 4: regular RC building with VED

Model 5: regular building with LRB

III. STRUCTURAL PROPERTIES OF MODEL

A) Description of G+13 building with descriptive data is mentioned below

Parameter	Dimensions
Type of building	Commercial building
Plan dimensions	40mx40m
Number of floors	13
X-direction length	40m
Y-direction length	40m
Floor height	3m
Bottom floor height	3m
Total height of building	50
Thickness of slab	150mm
Size of column	900x900mm
Size of beam	300x600mm
Seismic zone	IV
Seismic intensity	Moderate
Importance factor,I	1.5
Response reduction factor,R	5 for SMRF
Soil type	TYPE II (Medium soil)
Grade of concrete	M40
Reinforcement grade	Fe500
Unit weight of concrete	25kN/m ³

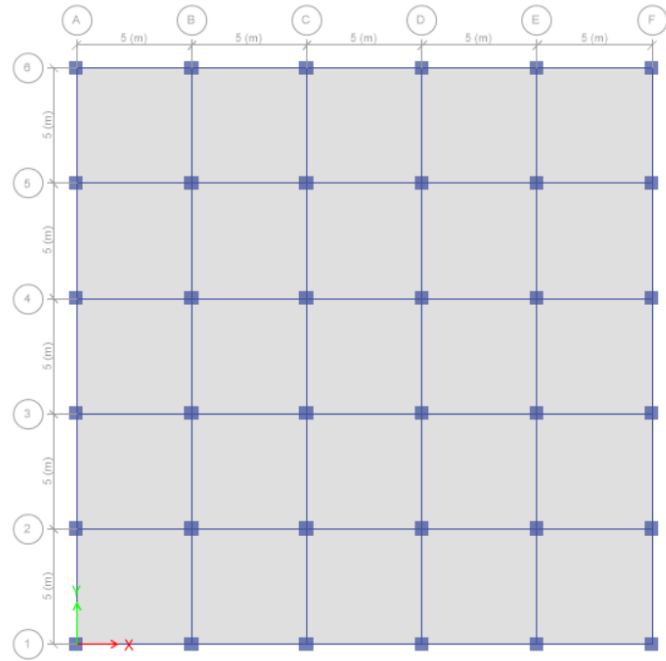

Fig 15: Plan view of G+10 Structure

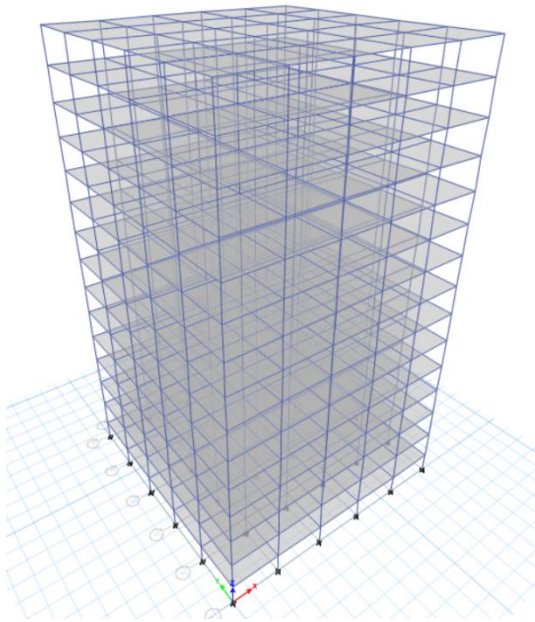

Fig 16: 3d view of G+10 Structure

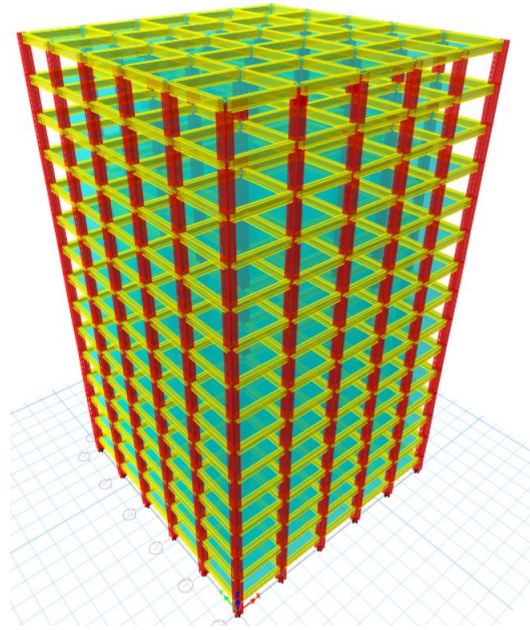

Fig 17: Extruded view of G+20 Structure

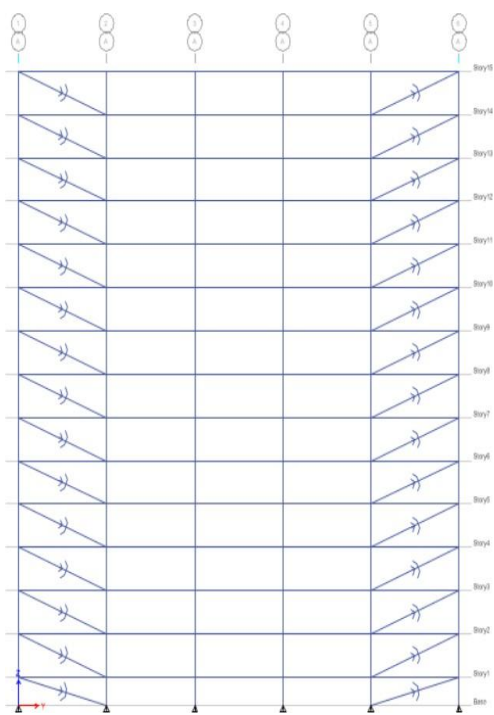

Fig 18: FPB

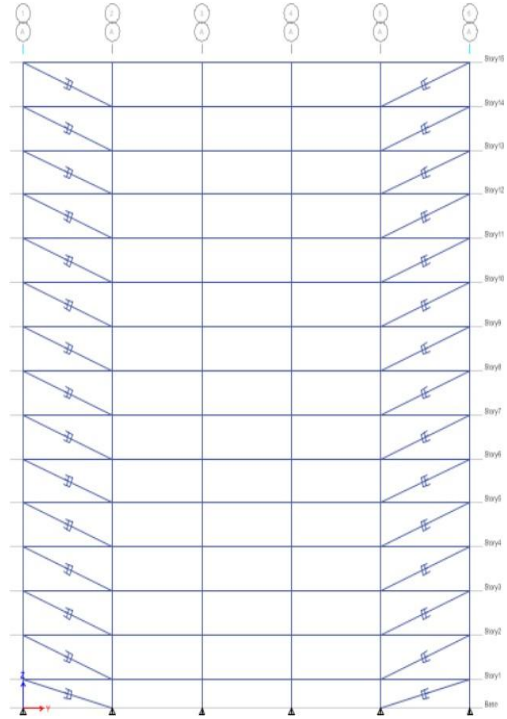

Fig 19: FVD

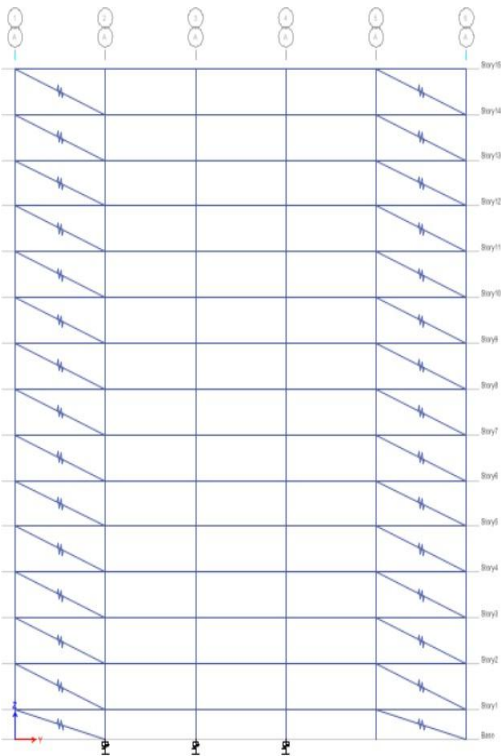

Fig 20: VED

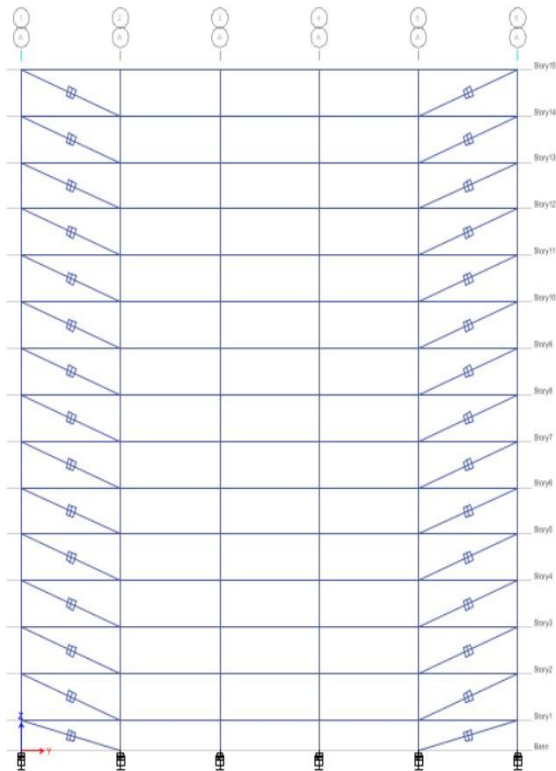

Fig 21: LRB

4. RESULTS AND DISCUSSION:

1. Storey Displacement:

As per IS Code 1893-2002, displacement is limited to $h/250$, where 'h' is total height of building in millimeters (mm). Therefore, the displacements in X and Y Direction lies within 168mm ($50000 / 250 = 200$) where 50000 mm is the height of model building.

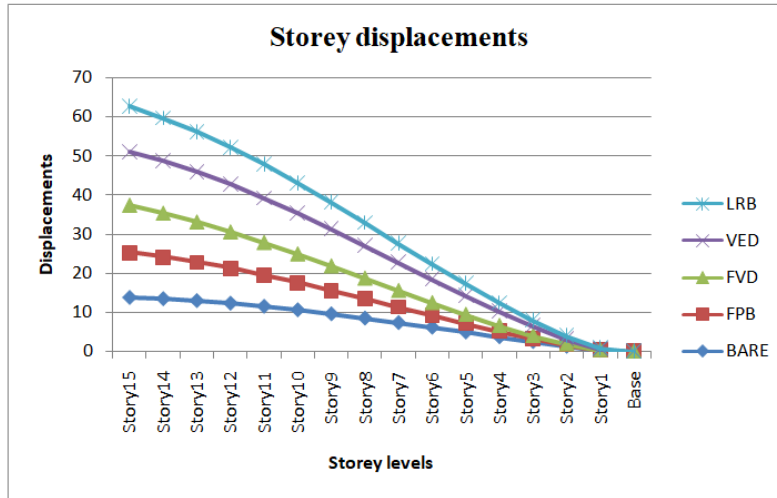

Fig 1: Storey displacement

2. Storey Drift:

Story drift can be defined as the ratio of relative displacements of adjacent two stories and height of the storey. According to IS 1893-2002, Clause no. 7.11.1, the Storey drift in any storey shall not exceed $0.004h$, where h is storey height. Drift is a result of shear and flexural responses, which is permitted to 12mm.

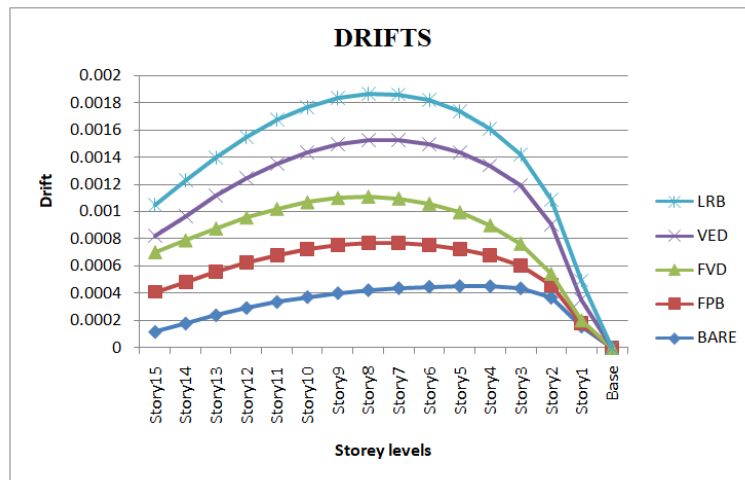

Fig 2: Storey drift

3. Storey shear:

Storey shear is the lateral load acting on each storey level. This force decreases as number of storeys increases resulting in reduction of inertia forces. Storey shear is reduced in Friction pendulum damper,

also reduced in base isolated building, resulting in making the superstructure above the isolation plane as rigid and stiffer. Compared to fixed base buildings, storey shear in these buildings are reduced to half.

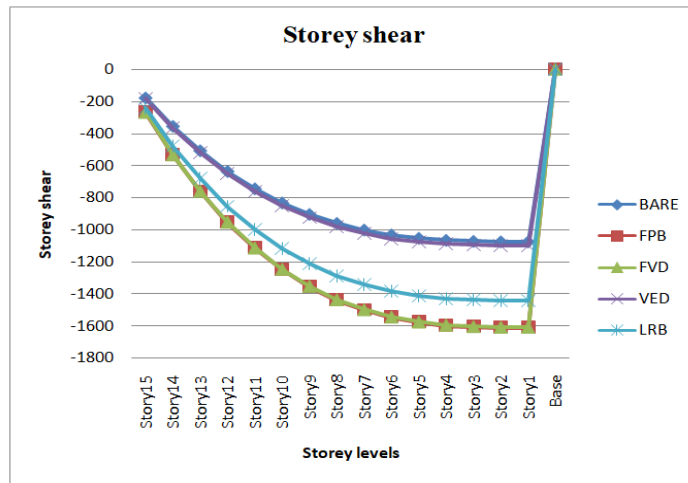

Fig 3: Storey shear

4. Overturning moments:

Maximum overturning moment is observed to be for Lead rubber bearing and the least is for Friction pendulum bearing as follows

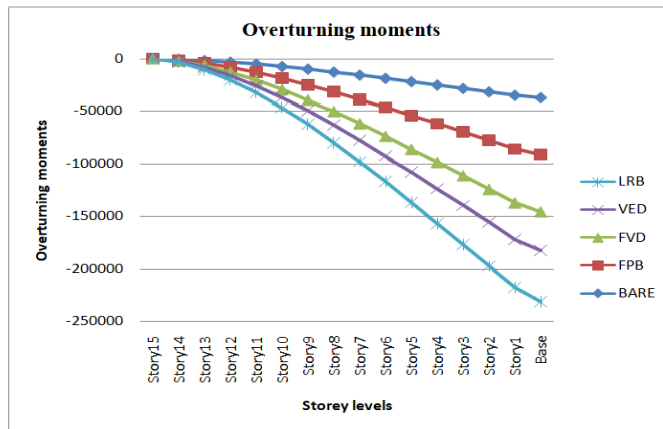

Fig 4: Overturning moment

5. Conclusion:

The output results of seismic parameters were obtained from analysis software ETABS. The results were analyzed, interpreted and compared. The findings of research are as follows.

- The base shear value in FPB building has been reduced up to 60 to 50% as compared to fixed base building.
- The target displacement limit has shown no failure when the structure is subjected to analysis.

- In this study more displacements are formed in Bare frame and least in model with Friction Pendulum Bearings..
- Also it has seen that the maximum overturning moments are formed in model with Friction Pendulum bearings. The structure models analyzed in this state is safe.
- The lateral load to stories is more in Bare followed with VED, LRB and FVD than FPB. But maximum story displacement and story drift results are also.
- The maximum Drifts is within the value of target drift that is assumed. The behavior of the structure is significant to resist the lateral loads.
- Top story drift of building has been decreased up to 60 to 62% by using FPB.

REFERENCES:

- [1] Venkatesh et.al “Dynamic analysis of 11 storey RCC structure by providing lead rubber base isolator “International Research Journal of Engineering and Technology (IRJET) e-ISSN: 2395 -0056 Volume: 03 Issue: 07 | July-2016.
- [2]IS 1893-2002, Indian standards code book for Earthquake resistant design of structure.
- [3]IS 875 PART 1 and PART 2 Indian standards code book for the dead loads and live load.
- [4]Vijay, U. P., Rajkumar, P. K., &Ravichandran, P. T. (2015). Seismic response control of RC structure using viscoelastic dampers. Indian Journal of Science and Technology, 8(28)
- [5]Zuhair Abd Hacheem and Israa Khudhair AL-Shimmari ,”Finite Element Analysis of a Friction Pendulum Bearing Base Isolation System For Earthquake Loads”, Journal of Engineering. 16,2010
- [6] P. Sajjan and P. Biradar, “Study On The Effect Of Viscous Damper For Rcc Frame Structure,”
- [7] P. Lakshmaiah Chowdary and G.karthic research paper on,“ Analysis Of A High Rise Residential Building With Viscous Dampers Using Etabs,”