

# Reliability and Maintenance of Assets in Electric Power Distribution network

## Abstract

Regular and stable supply of power to the consumers is very essential in the power system since reliability is one of the yardsticks that can be used to measure the performance of a service provider and reliability is ability of the system to function satisfactorily under stated condition at a particular period of time. Reliability and maintenance of assets in electric power distribution network was investigated using statistical analysis of outages data. Five years outages data caused by cables, transformers, breakers, line conductors and busbars & isolators were collected from Abule-Egba 33/11kV Injection substation in Ikeja Electricity Distribution Company, Lagos state and each year obtained data was represented in chart and also the comparison of the failures of different components within the observed years were represented in chart. Failure rate ( $\lambda$ ), reliability ( $R_t$ ) and Mean Time between Failures (MTBF) were calculated and the obtained results were typified by chart. From the calculations and the data obtained from the station, it was observed that transformers had the lowest reliability(46.61%) and cables had the highest reliability (82.95%).Engaging in preventive maintenance and predictive maintenance could enhance reliability of the system and this practice will in turn prevent or minimize failure rate of transformers and other devices.

**Keywords: Reliability, Assets, Power, Distribution, Network and Outages**

## INTRODUCTION

The electric power system is a very multifaceted infrastructure that is operated on a large- scale. Every human activity depends on it; hence it is expected to be reliable at all times. The probability that a power system will meet the load requirements of consumers at any time is referred to as power system reliability [1]. The primary goal of a power distribution system is to provide ample electricity to customers at a fair cost and with acceptable certainty of reliability. Over the last few years, electricity distribution networks have developed rapidly in terms of scale and technology. As a result, The Utility Company must endeavour to meet the customers' criteria

for reliability with the best strategic planning and the lowest feasible cost[3]. Reliability of Power system can be explained as the ability of the system to function satisfactorily under stated planned actions for a certain time frame [10] and [13]. It can also be described as the measure or probability that a product or service will work properly under normal operating conditions for a certain period of time [4] and [13]. Asset management (AM) is a theory that is used for the operation and planning of the electrical power system. The purpose of AM is to handle physical assets in a most favorable/best way in order to fulfill goals of an organization and also considering time risk. In numerous cases, equipment maintenance, repair, or replacement decisions have been made in the midst of a crisis, usually when critical equipment has failed and requires rapid attention [2]. In the power industry, AM is critical for detecting and evaluating actions that lead to long-term economic success and the highest feasible earnings. To live up to these expectations, asset management must overcome a variety of obstacles. Alignment of strategy and operations with stakeholder values and objectives; balancing dependability, safety, and financial considerations; profiting from performance-based rates; and living with the output-based penalty system are the four major hurdles. As a result, core AM responsibilities range from technical concerns like as network maintenance scheduling or the formulation of operational principles to broader economic concerns such as investment planning and budgeting, eventually leading to strategic planning concerns [8]. Based on the activity aspect, asset management is categorized into technical, economical and societal asset managements and they are described below [7]:

- ❖ **Technical asset management:** This term refers to asset-related parameters such as asset physical condition, inventory, and maintenance. Ageing of components is a major concern that is linked to asset physical condition. Component condition, asset failure likelihood, inventory of spare parts, and maintenance history or future planning are all aspects of this component. Economical asset management: When technical asset management proved to be financially unsustainable in many cases, economic asset management arose. Economic asset management, as the name implies, pertains to financial aspects such as maintenance costs and other costs associated with procuring spare parts, keeping inventories, and conducting tests and assessments.
- ❖ **Societal asset management:** Societal asset management works closely with economical asset management. It deals to how the use of a resource affects society and the

environment. Disturbances in other locations, such as schools, government offices, or convention centres, will have an impact on distribution companies' status.

Maintenance management (MM) is therefore defined as an approach to handle decisions for these assets and to make precise and wise decisions on:

- What assets to apply actions to
- what actions to apply
- how to apply the actions
- when to apply the actions

The idea of maintenance is to increase the life span of the equipment or at least the mean time to the next failure whose repair may be costly. In addition, it is likely that effective maintenance policies will decrease the frequency of service interruptions and many unwanted consequences of such interruptions. Maintenance clearly affects system and component reliability. When much effort is not put to maintenance, a lot of catastrophe will be recorded and this will in turns cause too much number of costly failures and the performance of the system and will eventually reduce reliability of the system [5] and [2].

The maintenance tasks may be categorized into the following:

- a) Routine inspection (RI) and visual and thermographic monitoring: This entails a visual inspection/investigation of the substation facilities' principal features without requiring them to be taken out of operation. Inspection findings may lead to the decision to perform additional maintenance.
- b) Inspections on all Circuit Breakers (CB), transformers and isolators etc to check for abnormal conditions on the equipment. The conditions and meter readings of the equipment shall be recorded on the approved check sheets or feedback templates provided with job plans.
- c) Minor maintenance: This entails the completion of scheduled or preventive maintenance work, which may necessitate the shutdown of substation facilities. Minor maintenance could be done on a time and/or operational basis.
- d) Major maintenance: This refers to work done with the goal of repairing, replacing, or changing parts or facilities as needed. Major maintenance may entail performing specialised maintenance that necessitates expert knowledge (live substation work)[8].

## **Maintenance**

Maintenance is when the physical assets are continuously doing what their operators want them to perform. This will depend on how and where the asset is being employed (the operating context). Maintenance procedures are an integrated part of the planning, construction and operation of a system. Moreover they are crucial and central to the effective use of available equipment. The goal of maintenance efforts is to consistently satisfy reliability, performance, and cost targets while adhering to the limits imposed by system and customer requirements [11]. All operations taken to retain or restore equipment to a desired state are included in the maintenance concept [9]. When dealing with system assets, the cost of maintenance must be considered in order to reduce the system's lifetime expenses. However, some maintenance activities must be undertaken even if when they are not profitable, such as earth – plate – metering inspections stipulated in the IEE regulations for power system [6].

## **Methodology**

In some cases, the distribution network will contain the following: Transformers, fuses, lines conductors (lines, poles and related items), cables (cables, junctions and related items), breakers, bus coupler, isolators and bus bars.

But five years outages caused by Cables, Breakers, Transformers, Bus bars & Isolators, Line conductors would be analyzed. Five years power outages that occurred as a result of improper planning, equipment failures and scheduled maintenance will be collected and outages due to insufficient power generation would be excluded. The data will be collected from Abule-Egba 33/11kV Injection substation in Ikeja Electricity Distribution Company, Lagos state. Equipment Maintenance is very important part of power systems. The power industry is highly demanding and competitive. Adequate planning and preparation towards maintenance will amount to a crucial part of reliability and asset management in distribution sector of power system because, in this part of the world only breakdown maintenance is been practiced. The outcomes of this will be regular and unannounced power failures and interruptions. The major challenge in the power industries today, especially the developing countries is that the demand for power is increasing speedily and the supply growth is forced by ageing generating stations/ plants and ageing distribution facilities and resources to construct new ones are not readily available

## Basic Theory of reliability

$R(t)$ : is the reliability function: this is the probability of finding a healthy component in a healthy state after a time  $t$ ,

$f(t)$ : Failure density distribution: This is the rate at which a component will fail at time  $t$ .

$h(t)$ : Hazard rate: The rate at which a component fails at time  $t$  given that it is healthy until time  $t$ .

$\lambda$  = failure rate

$t$  = time

$\mu$  = Repair Rate

Power equipment and power systems are vulnerable to failures that occurred due to internal or external sources. The failure of a component is the inability of a component to perform its intended /planned function at a particular time under specified operating conditions.

A failure is specified by its failure rate and repair rate.

Further reliability parameters given are also given as follows:

- **MTTF (Mean Time to Failure)**: The average time it takes for a healthy component before it fails.
- **MTTR (Mean Time to Repair) or Repair Time**: This is the average time it takes to repair a failed component.

$$MTTR = \frac{\text{Total duration of outages}}{\text{Frequency of outages}} \quad (1)$$

- **MTBF: Mean Time between Failures**: This is the average time between two failures of the components. i.e.

$$MTBF = \frac{\text{Total System operating hours}}{\text{Number of failures}} \quad (2)$$

$$MTBF = MTTF + MTTR = \frac{1}{\text{Frequency}} \quad (3)$$

$$\text{Availability (A)} = \frac{MTBF - MTTR}{MTBF} \quad (4)$$

From these parameters, some other parameters can be derived (when assuming the negative exponential distribution) [12]:

- $\lambda = 1/MTTF$ : Failure rate: The rate at which a healthy component fails.

- $\mu = 1/\text{MTTR}$ : Repair rate: The rate at which a failed component is repaired.
- $f = 1/\text{MTBF}$ : Failure frequency: The average frequency at which a component fails.

The failure rate ( $f_t$ ) can be calculated as shown below in equation (5)

$$f_t = \frac{n_f}{n_s} \text{ Or } \frac{n_f}{n_o} = \lambda \dots\dots\dots (5)$$

$$f_t = \lambda$$

Where,  $n_f$  = number of failures per year

$n_o$  = Total number of observation per year

$n_s$  = total number of successes per year

The failure rate for the total numbers of the observed n consecutive years can be expressed as

$$\lambda_t = \lambda_1 + \lambda_2 + \lambda_3 + \lambda_4 + \dots\dots + \lambda_n \dots\dots\dots (6)$$

And n = number of the observed years

Reliability is given as,

$$R_t = e^{-\lambda t} \dots\dots\dots (7)$$

$$R_t = P(T > t) = 1 - f_t \dots\dots\dots (8)$$

$$R_t = 1 - f_t \dots\dots\dots (9)$$

Therefore Reliability of the system would be evaluated by using equation (9).

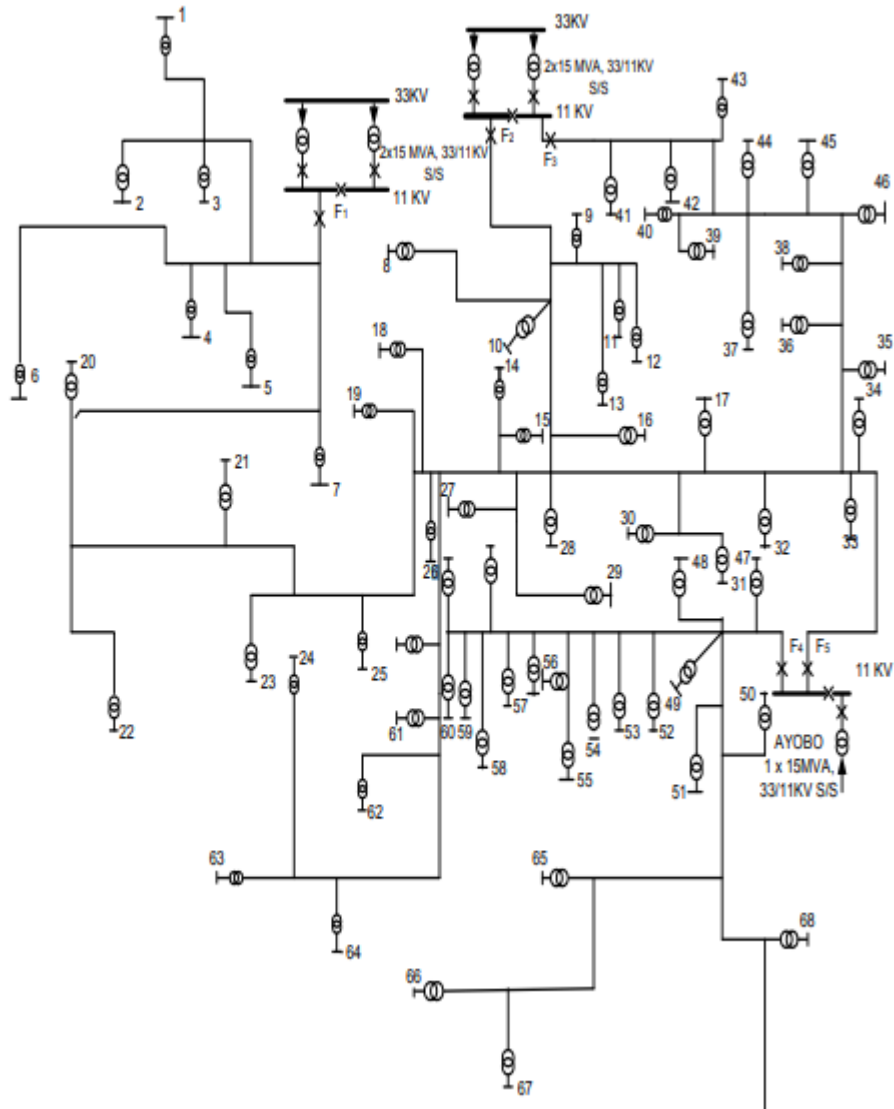

Figure1: A cross-section of the Abule Egba distribution business unit [2].

Table1: Power outages obtained from the Injection Substations.

S/N	Names of the failed components	2015 power outages	2016 power outages	2017 power outages	2018 power outages	2019 power outages
1	Cables	10	15	12	15	10
2	Breakers	25	40	20	29	30

3	Transformers	40	50	35	30	40
4	Busbars & Isolators	15	20	20	25	27
5	Line Conductors	10	15	11	15	20
<b>Total observed outages per year</b>		100	140	98	114	127

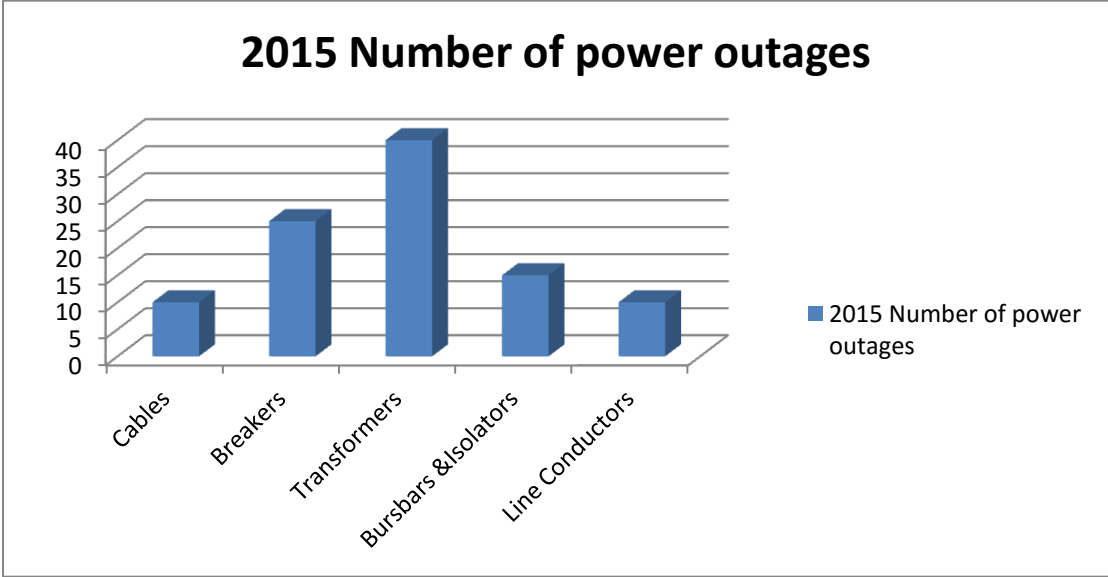

Figure2: 2015 distribution components power outages.

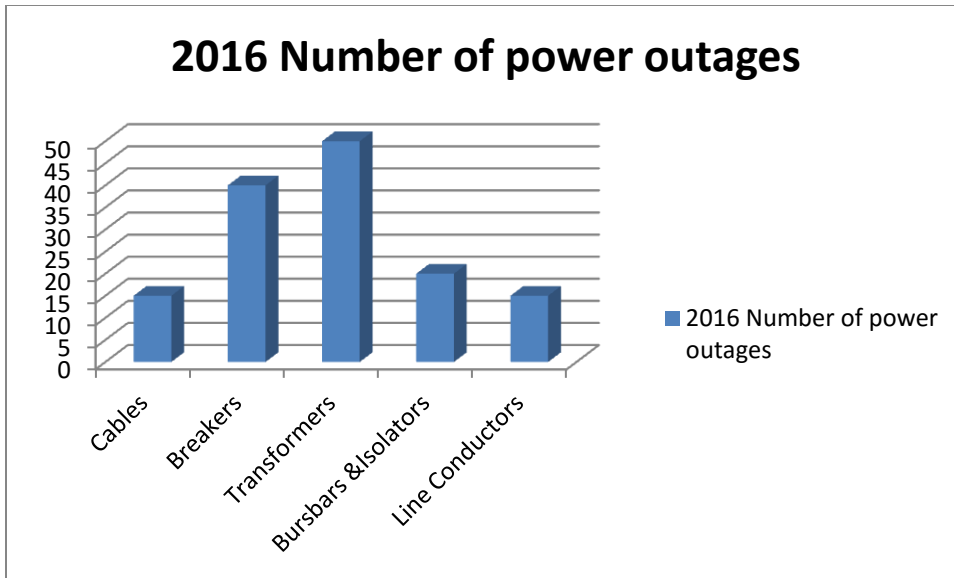

Figure 3: 2016 distribution components power outages.

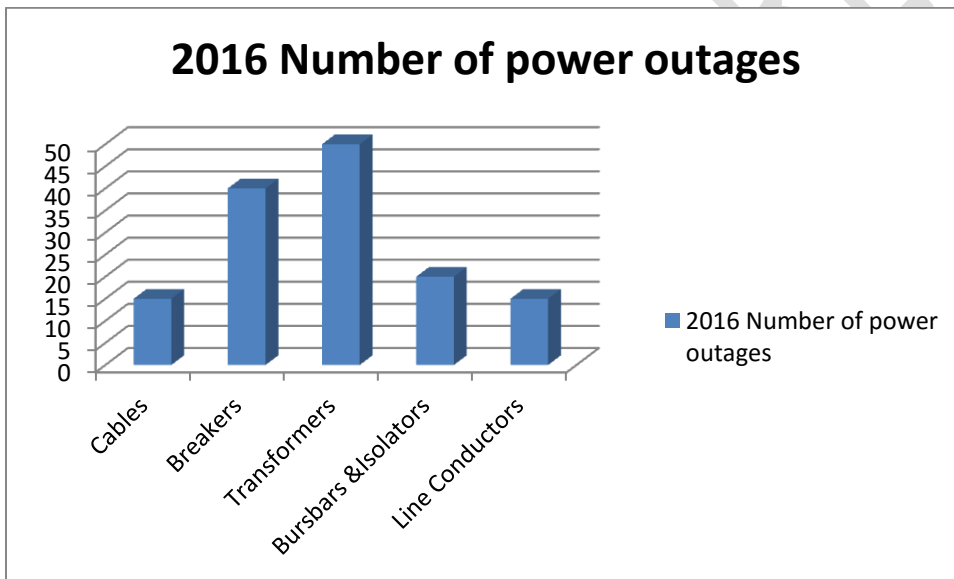

Figure 4: 2017 distribution components power outages.

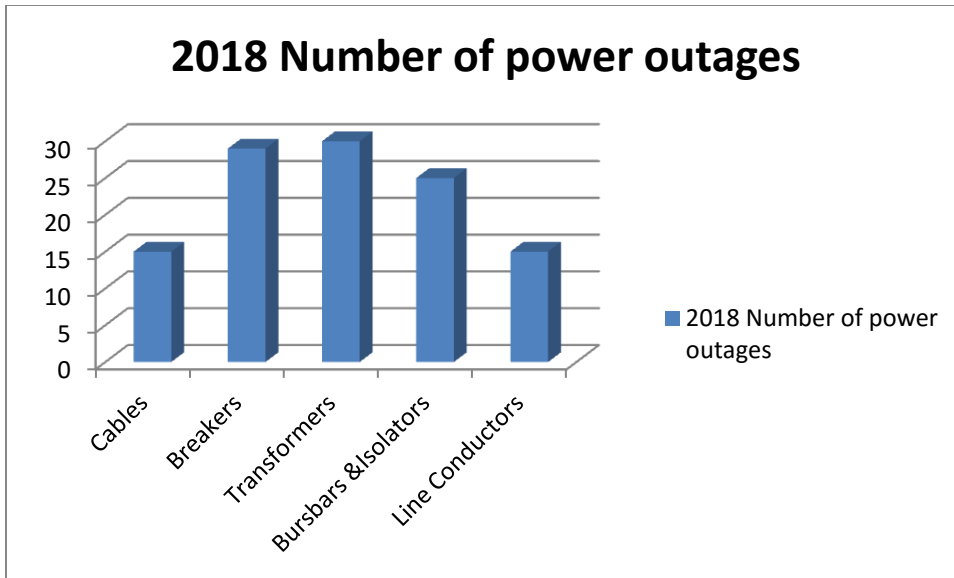

Figure 5: 2018 distribution components power outages.

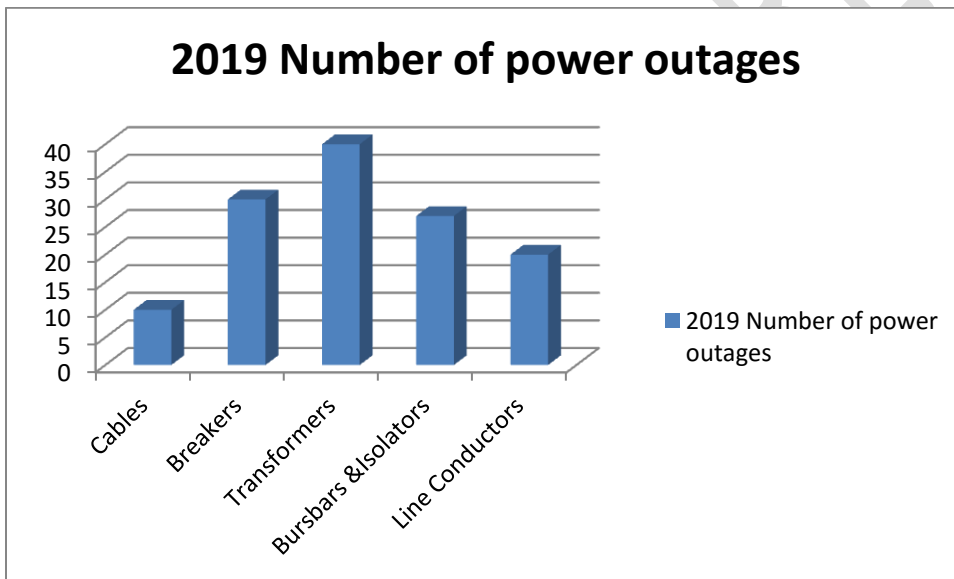

Figure 6: 2019 distribution components power outages.

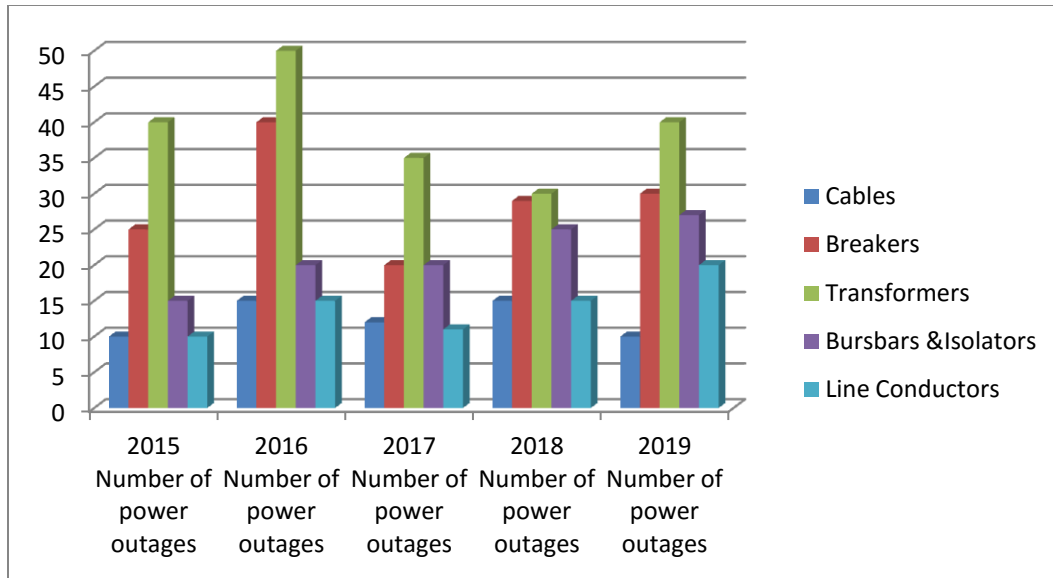

Figure 7: Comparison of the failures of different components within the observed years (2015 to 2019).

Table 2: failure rate ( $\lambda$ ), reliability ( $R_t$ ) and Mean Time between Failures Mean Time (MTBF) between Failures

S/N	Components	Failure rate ( $\lambda$ )	Reliability ( $R_t$ )	MTBF = $\frac{1}{\lambda}$
1	Cables	<b>0.1705</b>	<b>82.95%</b>	<b>5.865</b>
2	Breakers	<b>0.2958</b>	<b>70.42%</b>	<b>3.381</b>
3	Transformers	<b>0.5338</b>	<b>46.61%</b>	<b>1.873</b>
4	Busbars & Isolators	<b>0.2938</b>	<b>70.62%</b>	<b>3.4037</b>
5	Line Conductors	<b>0.1951</b>	<b>80.49%</b>	<b>5.1256</b>

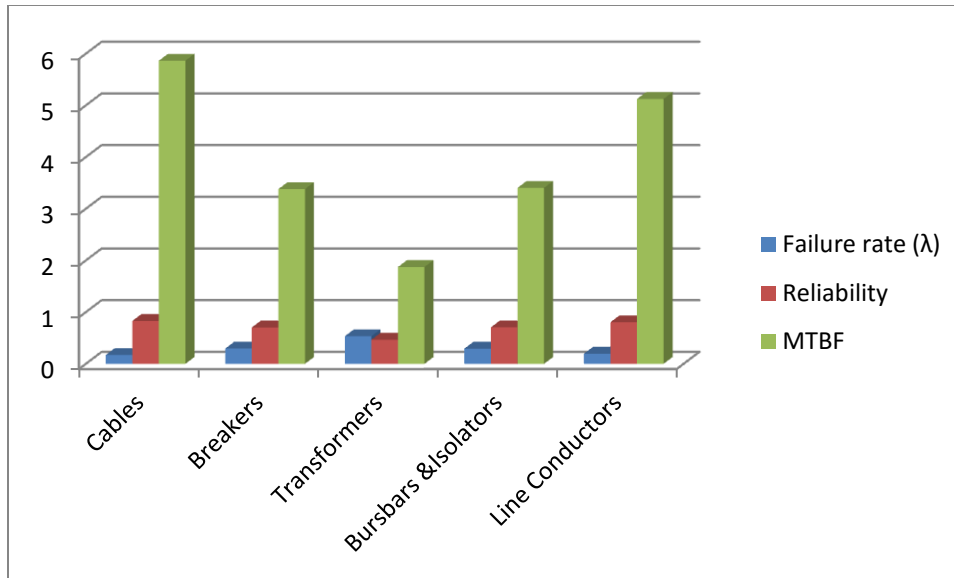

Figure8: Chart representing the failure rate ( $\lambda$ ), reliability ( $R_t$ ) and Mean Time between Failures (MTBF).

## Conclusion

Reliability and Maintenance of Assets in Electric Power Distribution network using Statistical Analysis of outages data was investigated from 2015 to 2019 using Abule Egba Business unit as a case study. The data was collected from the data log book of 33/11kV of Abule Egba injection Substation. This injection substation is been fed by 4x60MVA, 132/33kV, this injection substation in turn feed Thirty-three 11kV different customer feeders with 700 different loads – points. The obtained data were analyzed by equations (1-9) and Table1 was used to represent the power outages obtained from all the assets under investigation and also, Table 2 represented the failure rate ( $\lambda$ ), reliability ( $R_t$ ) and Mean Time between Failures (MTBF). Similarly, Figures 2-6 signified the distribution components of power outages from 2015 to 2019, Figure 7 indicated the comparison of the failures of different components within the observed years (2015 to 2019) and Figure8 displayed the failure rate ( $\lambda$ ), reliability ( $R_t$ ) and Mean Time between Failures Mean Time (MTBF). From the calculations and obtained data it was observed that transformers had the lowest reliability (46.61%) ,it may be due to the fact that it very vital in power system and most of the faults on power system do happen on transformers and cables had the highest reliability (82.95%).Engaging in preventive maintenance and predictive maintenance could

enhance reliability of the system and this practice will in turn prevent or minimize failure rate of transformers and other devices

#### **COMPETING INTERESTS DISCLAIMER:**

**Authors have declared that no competing interests exist. The products used for this research are commonly and predominantly use products in our area of research and country. There is absolutely no conflict of interest between the authors and producers of the products because we do not intend to use these products as an avenue for any litigation but for the advancement of knowledge. Also, the research was not funded by the producing company rather it was funded by personal efforts of the authors.**

#### **References**

- [1] Adefarati T. and Bansal R.C. Reliability and economic assessment of a microgrid power system with the integration of renewable energy resources, *Applied Energy journal homepage: www.elsevier.com/locate/apenergy.2017,911-933.*
- [2] Adoghe A. U. Reliability Centered Maintenance (Rcm) for Asset Management in Electric Power distribution System, *PhD Thesis.2010, Covenant University Ota, Ogun State, Nigeria.*
- [3] Akhikpemelo A., Eyibo N. and Adeyi A. Reliability Analysis of Power Distribution Network, *Continental Journal Engineering Sciences.2016, 11 (2), pp.53 – 63, Nigeria.*
- [4] Amuta E., Adejumobi I.A, Wara S.T and Abiala I.O. A Critical Analysis of the Reliability of Power Holding Company of Nigeria Protection Schemes, *International Journal of Engineering and Technical Research (IJETR).2014, ISSN: 2321-0869, Volume-2, Issue-5, Pp 369-372.*
- [5] Danyel, P. R., Lavelle A.A. and Richard, E.B. Overcoming Data Problems in Predictive Reliability Distribution Modeling. *IEEE Computer Applications in power .2001.*
- [6] Endrenyi, J., Anders, G.J. and Bertling, L.Comparison of two methods for evaluating the effects of Maintenance on Component and System Reliability, *8th International Conference on Probabilistic Methods Applied to power Systems, Iowa state University, Ames, Iowa.2004,12-16.*

- [7] Khuntia, S., Rueda Torres, JL., Bouwman, S., & van der Meijden, M. A literature survey on asset management in electrical power [transmission and distribution] system. *International Transactions on Electrical Energy Systems*.2016, 26(10), 2123-2133. <https://doi.org/10.1002/etep.2193>.
- [8] Morad M., Abdellah E. and Ahmed El K. A maintenance optimization policy for an electric power distribution system: case of the hv/mv substations, *Scientific Research Journal*.2014, 5(6) , <http://creativecommons.org/licenses>.
- [9] Rinaldi, S.M. Modeling and Simulating Critical Infrastructures and Their Interdependencies, *Proceedings of the 37th Hawaii International Conference on System Sciences*.2004, pp. 1-8.
- [10] Sultana, Beenish M.W., Mustafa U. Sultana, and Abdul Rauf Bhatti. Review on Reliability Improvement and Power Loss Reduction in Distribution System via Network Reconfiguration. *Renewable and Sustainable Energy Reviews*.2016, 66: 297–310.
- [11] Yujia, Z, Anil P, and Shie-shien, Y. Modeling Weather-Related Failures of Overhead Distribution Lines, *IEEE Transactions on Power Systems*.2007, 4(21), pp. 1-1.
- [12] Venkatesan, Latha, S Shanmugavel, and Chandrasekaran Subramaniam. A Survey on Modeling and Enhancing Reliability of Wireless Sensor Network.” *Wireless Sensor Network* .2013,Pp 41–51
- [13] Olajuyin E.A.,Akinyede J.A and Akinyede T. (2021). Evaluation of reliability of protective devices in power distribution network, *Journal of Emerging Trends in Engineering and Applied Sciences (JETEAS)*,12(1):13-18