

DEVELOPMENT OF COMPUTER VISION SYSTEM FOR FRUITS

ABSTRACT

Automated defect detection of fruits using computer vision and machine learning concepts has become a significant area of research. In this work, working prototype hardware model of conveyor with PC is designed, constructed and implemented to analyze the fruit quality. The prototype consists of low-cost microcontrollers, USB camera and MATLAB user interface. The automated classification model rejects or accepts the fruit based on the quality i.e., good (ripe, unripe) and bad. For the classification of fruit quality, machine learning algorithms such as Support Vector Machine, KNN, Random Forest classifier, Decision Tree classifier and ANN are used. The dataset used in this work consists of the following fruit varieties i.e., apple, orange, tomato, guava, lemon, and pomegranate. We trained, tested and compared the performance of these five machine learning approaches and found out that the ANN based fruit detection performs better. The overall accuracy obtained by the ANN model for the dataset is 95.6%. In addition, the response time of the system is 50 seconds per fruit which is very low. Therefore, it will be very suitable and useful for small-scale industries and farmers to grow up their business

Keywords: Computer vision, Image processing, ANN, KNN, SVM classifier, fruits inspection.

1.INTRODUCTION

The farming industry plays an essential part in the economy of several nations in the world. The developing interest for successful food creation and fast and safe stock to the market has encouraged the chance of utilizing different innovative advanced technology in this agriculture industry [1]. The innovations like the Internet of Things (IoT) based on strong cultivating have been found helpful in working on the nature of products of the vegetable yields [2]. Also, the utilization of better technologies by medium and large scope ventures has an opportunity to sort, bundle and transport the better-quality product to the market [3]. Even though most of the small and medium scale industries have lacked good technologies in automation. the two major reasons are the overall cost of the product and the lack of learning the new technologies Henceforth, there is a rising need to develop minimal expense and simple to-utilize solutions for these agriculture industries so that they can get more advantages with the help of new technologies.

The information and data in agriculture essentially begin from visual picture images, however processing visual information is very challenging. In this manner, advanced image processing techniques assist to analyze visual images. Image processing has different applications in the field of agriculture like distinguishing proof of land [4] assessment of plant nitrogen content, inspection of bug-infected regions

1 [5], and discovery of plant diseases from shape, surface, and shading [6]. As data science is quickly
2 developing, computer vision-based recognition and image processing are developed good techniques for
3 security and quality examination of a few farming applications. Computer vision-based system captures
4 the images through an external camera and analyzes through the computer.

5 In the past, multiple efforts have been made to automate the fruits' classification problem based
6 on their outer appearance or freshness by employing computer vision and machine learning techniques
7 [7]. However, in most of these studies, grading has been done using the traditional approach of feature
8 extraction and applying machine learning techniques. For example, in [8] the apples have been classified
9 by using colour, texture, and shape feature descriptors, namely Global Colour Histogram, Colour
10 Coherence Vector (CCV), Local Binary Patterns (LBP), Complete Local Binary Patterns (CLBP), and
11 Zernike Moments (ZM). The extracted features were used individually as well as in combination to train
12 and test the machine learning techniques with the highest accuracy of 95.9% using a combination of
13 CCV, CLBP, and ZM. Further, in [9] both unsupervised and supervised learning algorithms have been
14 used for apples' grading. Initially, K-means clustering was used for the segmentation of defected apples,
15 and in the next stage statistical, textural, and geometric features were extracted from the refined defected
16 regions. These features were used to train, test, and compare the performance of three machine learning
17 techniques namely Support Vector Machine (SVM), MLP, and K-Nearest Neighbor (KNN). The results of
18 this study showed the highest grading results using an SVM classifier with recognition rates of 92.5% for
19 healthy and defected categories and 89.2% for three quality categories (in terms of ranks). In recent
20 research on measuring the ripeness quality on bananas, an artificial neural network (ANN) based
21 framework has been proposed using different features like colour, development of brown spots, and
22 Tamura statistical texture [10]. The performance of the ANN model was compared with various other
23 techniques including SVM, naive Bayes, KNN, decision tree, and discriminant analysis. The findings
24 showed that the proposed system has the highest overall recognition rate 97.75%. Similar approaches
25 have been followed for determining the ripeness and maturity level of other fruits including blueberry [11],
26 oil palm fruit [12], and oranges [13]. Though the performance of the machine learning models in these
27 studies is quite good these models are mainly based on the hand-crafted feature extraction methods
28 which are mostly time-consuming and dependent on the type of images (fruits) used for training and
29 testing. Moreover, these models have been trained and tested only for small datasets which increases
30 the risk of biased predictions.

31 **2. MATERIALS AND METHODS**

32 **2.1. The automatic fruit inspection prototype**

34 The main aim of the proposed approach is to provide an automated classification system for
35 different fruits and evaluations by classifying them based on defect and colour. The proposed system is
36 capable of classifying fruits. The dataset used for this study is based on real sample images of 'fruit
37 varieties, which were collected from local fields. A working prototype hardware model of conveyor is to be
38 designed and implemented in this research work. Computer vision techniques and machine learning
39 algorithms were used for fruit inspection and grading. A Quantum QHM495 LM USB web camera with a

1 resolution of 25 megapixels with 30 frames per second is used to prepare a dataset using six different
2 fruits like Lemon, Apple, Guava, Orange, Pomegranate, and Tomato. The images of all these fruits are
3 taken in ripe and unripe categories as well as good and rotten fruit categories. Once the preparation of
4 the dataset for all the three different fruits is completed, the fruit is subjected to testing into a conveyor
5 system for automatic detection and classification.

6 The fruit to be tested is placed on the circular slab and the USB camera captures images at
7 30fps and save it in jpeg format. This image is sent to PC for classification. For Image feature extraction
8 single-Level 2-D Discrete Wavelet Transform is used and five different Machine Learning algorithms are
9 selected namely SVM [14-16], KNN [17,18], ANN [19-21], Random Forest classifier, and Decision Tree
10 classifier for classification. Since the machine learning algorithms are separately trained on the training
11 dataset, now it is tested on the test data. The testing results are evaluated using the accuracy of
12 classification. After experimentation it is found out that among the five classification ANN is found out to
13 give better accuracy. The classified output is sent from PC to Arduino microcontroller via serial port. The
14 Arduino Microcontroller sends this digital output to PIC Microcontroller for displaying the classified output
15 on LCD. The conveyor system operates using five gear motors for different operations.

16 The PIC microcontroller operates these motors via the attached relay unit. The two motors are
17 used for tilting and rotating the circular slab. The rotating operation of the circular slab is to take pictures
18 of the fruit placed on the slab. The tilting operation of the circular slab is to drop the fruit into the
19 conveyor. The other two motors drive the conveyor belt and the fifth motor for the door opening and
20 closing mechanism. A small door mechanism is fixed on the conveyor system. This door opens when the
21 detected fruit is bad and rejects the fruit from the conveyor. This door closes when the detected fruit is
22 good or ripe/unripe and travels along the conveyor.

23 24 **2.2 Hardware Model**

25 For real-time testing of the model, a prototype system was developed. The hardware of the
26 prototype system consists of two microcontrollers [22] units Arduino (Atmega328 version R2) and PIC (
27 PIC 16F877A) modules. The classified output is sent from PC to Arduino microcontroller via serial port.
28 The Arduino Microcontroller sends this digital output to PIC Microcontroller for displaying the classified
29 output on LCD. The conveyor system operates using five gear motors for different operations. The PIC
30 microcontroller operates these motors via the attached relay unit. The two motors are used for tilting and
31 rotating the circular slab. The rotating operation of the circular slab is to take pictures of the fruit placed
32 on the slab. The tilting operation of the circular slab is to drop the fruit into the conveyor. Hardware Model
33 Diagram is shown in the figure 1.

34 The other two motors drive the conveyor [23,24] belt and the fifth motor for the door opening and
35 closing mechanism. A small door mechanism is fixed on the conveyor system. This door opens when the
36 detected fruit is bad or unripe and rejects the fruit from the conveyor. This door closes when the detected
37 fruit is good or ripe and travel along the conveyor

38
39
40

1
2
3
4
5
6
7
8
9
10
11
12
13
14
15
16
17
18
19
20
21
22
23
24
25
26
27
28
29
30
31

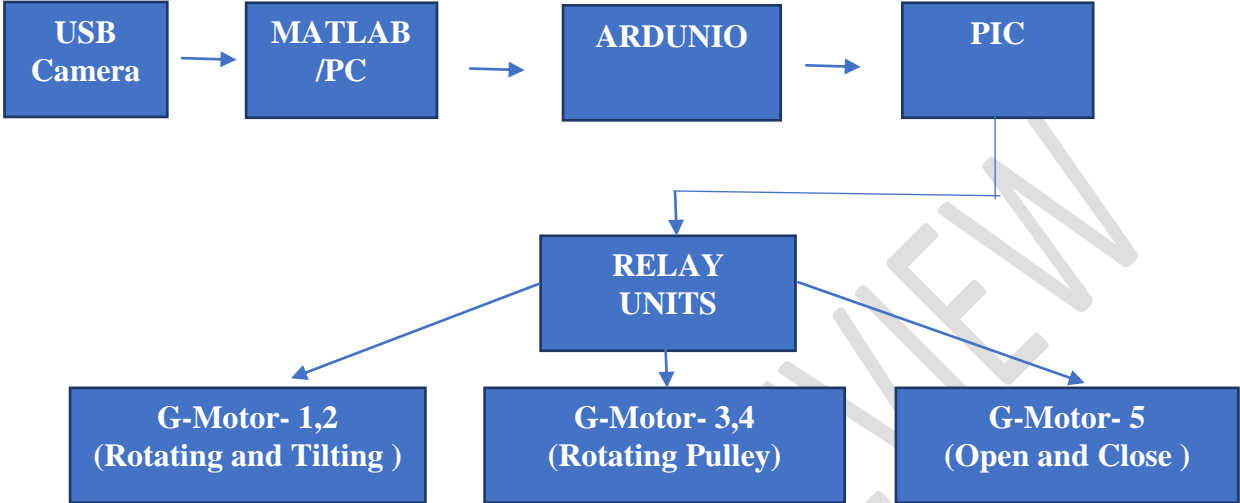

Figure 1: Hardware Model Diagram

2.2.1 Image Acquisition

An USB camera is connected to the system to capture the fruit which is programmed in MATLAB. For this, a Quantum QHM495LM web camera which is a high-resolution webcam delivers great video quality, and imaging quality is selected. The QHM PC Camera (QHM 495 LM) features 6 white lights and has an image resolution of 25 megapixels(Figure 2). The camera operates on CMOS sensors and has a potentiometer that switches on the lights when operating in the dark. It supports Automatic Whiteness Balance that precisely captures true colours even in mixed lighting conditions. The camera is set to an anti-flicker of either 50 Hz or 60 Hz to get great resolutions while using it outdoors. This webcam connects to PCs and laptops via a high-speed USB 2.0 interface.



Figure 2 Web Camera (QHM 495 LM)

2.3 Conveyer Hardware Setup

1 The hardware section consists of a belt [25] conveyor used for the classification of fruits and a
2 rotating circular slab where the fruit is placed and delivered to the belt conveyor. A USB camera is used
3 for taking images. This section also contains an open-close gate for directing the fruits in the specific
4 collecting place based on the classification.

5 Component parts that are used in designing the conveyor are

- 6 ➤ Belt
- 7 ➤ Gear Motor
- 8 ➤ Pulley

9 A prototype low-cost belt conveyor was designed with dimensions 1 m length and 0.12 m width which
10 could be able to carry a fruit of 250 gm. For this, a Nylon belt was selected. Nylon was an ideal
11 replacement for cotton and was the first polyamide synthetic fiber to be utilized in belting construction
12 which is shown in figure 3. However, it has several positive attributes such as

- 13 1. Brilliant fatigue, impact, and mildew resistance
- 14 2. Good resistance to abrasion
- 15 3. Good resistance to impact fatigue and strength.

16

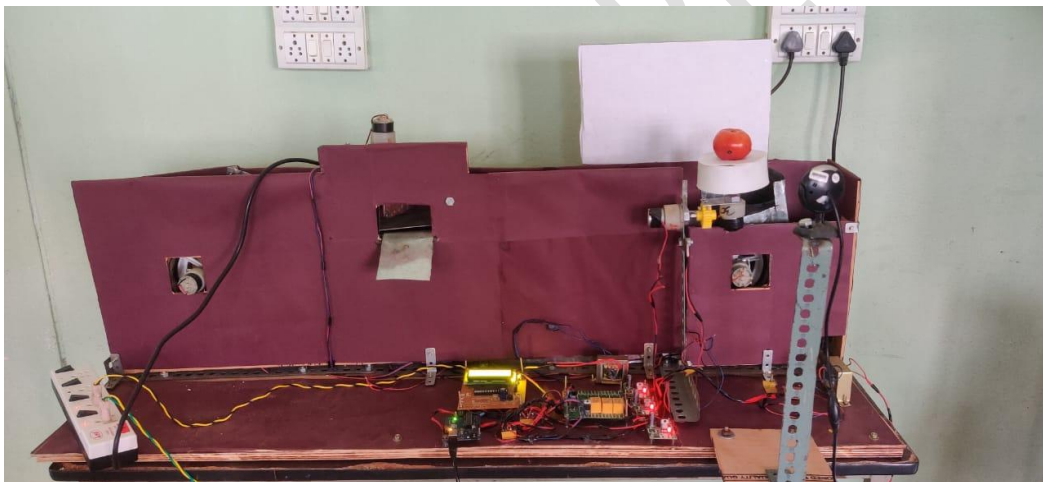

17

18

Figure 3: Conveyer Full setup

19

20 To develop a lab model conveyor prototype where a 1M length 3ply nylon belt material would be selected
21 with a width of 4.5 inches where small and medium-size fruits can be handled for classification. the
22 proposed conveyor system could be built with the gear motors. Rotating slab is shown in figure 4.



Figure 4: Rotating and tilting the circular Tab

1
2
3 A total of five gear motors is used in the construction of the conveyor system [26]. Two gear motors are
4 used to rotate the pulleys. One pulley is attached to the open/close gate. Two pulleys are used for
5 rotating circular disc for rotating and tilting action. 12 Volts geared motors are used in developing the
6 system. The 12Volts geared motors are generally simple DC motors with a gearbox attached to them.
7 This can be used in all-terrain robots and a variety of robotic applications. These motors have a 3 mm
8 threaded drill hole in the middle of the shaft thus making it simple to connect it to the wheels or any other
9 mechanical assembly. 12V DC geared motors are widely used for robotics applications.

10 Pulley Wheel is mostly used which is easy to mount, durable and cheap. These wheels have a 6mm hole
11 for a shaft with the screw for fitting making it very easy to mount on motors. This has a smooth surface
12 and is lightweight. Two gear motors are connected to the pulley wheels which are situated at the ends to
13 move the belt. To develop the proposed system pulley wheels of 10 cm in diameter and 4 cm width with
14 a 6mm shaft bore is required to move a belt that can convey fruits of 250gm.

16 **2.3.1 Microcontrollers specifications**

17 This section is the core of the proposed system where it acts as a bridge between the hardware section
18 where classification is carried on a belt conveyor and the software section where the software that works
19 for the classification of fruits. The actuating and control system works when the relay turns ON after
20 receiving signals from microcontroller. The actuating system consists of Arduino Uno Microcontroller
21 [27],PIC Microcontroller and Relay units, LCD modules, Potentiometer, Transformer, Bridge Rectifier,
22 Electrolytic capacitors, Regulator. Here, in addition to the PIC microcontroller where motors and displays
23 are connected, an Arduino microcontroller is used because of limited interface pins.

24 The Arduino Uno is a microcontroller board based on the ATmega328. It has 14 digital input/output pins
25 (of which 6 can be used as PWM outputs), 6 analog inputs, a 16 MHz ceramic resonator, a USB
26 connection, a power jack, an ICSP header, and a reset button. The Uno differs from all preceding boards
27 in that it does not use the FTDI USB-to-serial driver chip. Instead, it features the Atmega16U2
28 (Atmega8U2 up to version R2) programmed as a USB-to-serial converter.

29 The PIC microcontroller is interfaced between UNO and relay units. A microcontroller (also MCU or μC) is
30 a functional computer system-on-a-chip. It's getting the input from the computer and Rotate both the
31 pulley motors anti-clockwise direction. Circuit diagram is shown in the figure 5.

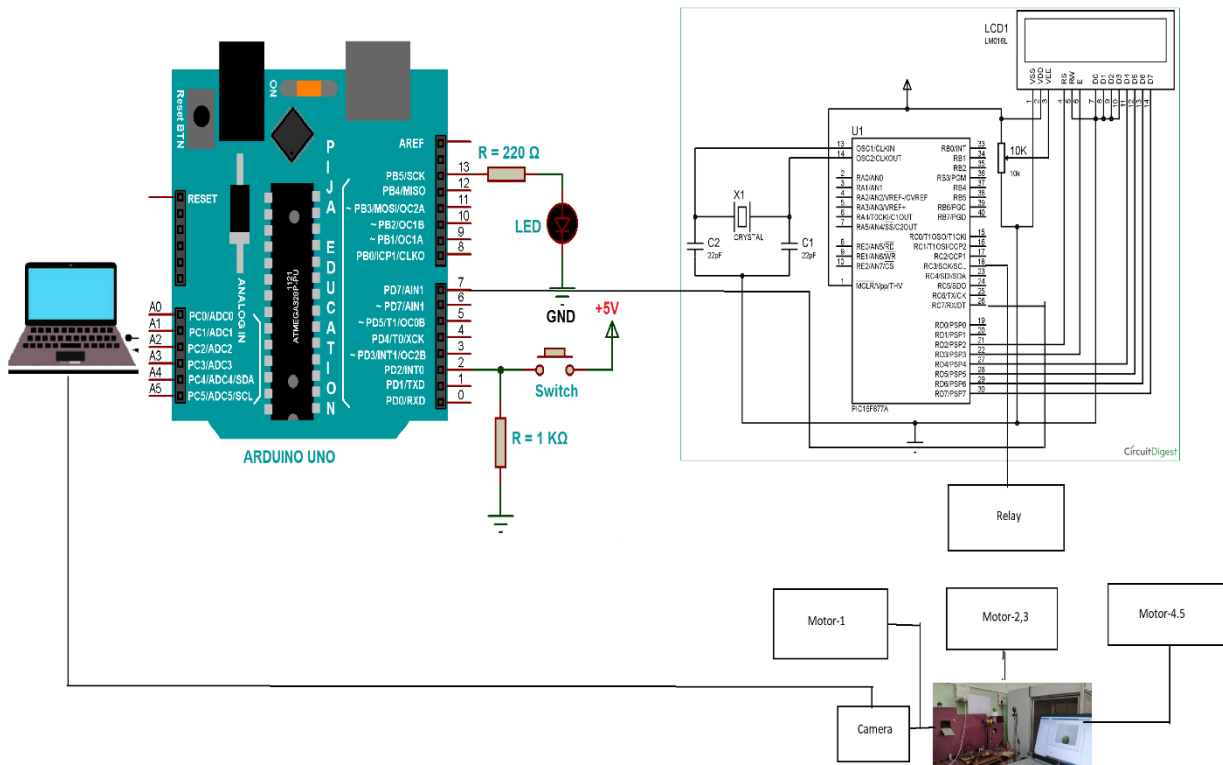

Figure 5: Circuit Diagram

2.3.2 Database creation

A hundred fruits each of mature, immature, and defected were procured from the local market yard (mandis). Where fruits were manually graded by the farmers as matured, immature, and defective. To minimize the noise in the image of fruits could be cleaned from the dust and foreign material before capturing the images. Then data base can be prepared to place each fruit on the circular slab which is an integral part of the conveyor [28,29] belt images will be captured by USB Camera [27]. Creating two separate folders one for matured and the other for defected fruits and then segregating those photos in the respective folders and image capturing is shown in figure 6. For creating the dataset, the captured images from the camera are cropped to 680x420 for all the images and the saved images are renamed in the corresponding folders for further processing.

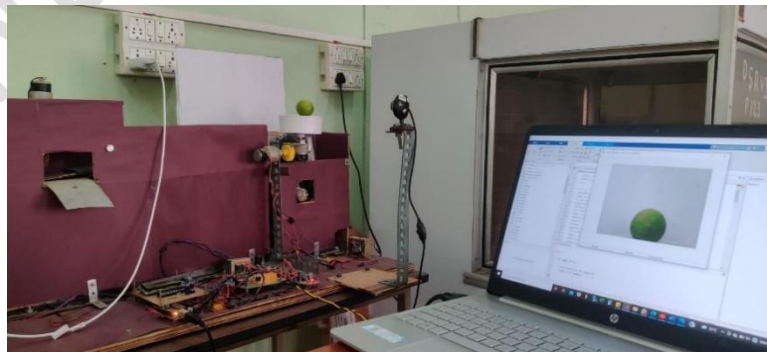

Figure 6: Database creation

1 **2.3.3 Procedure for creating the dataset**

- 2 Step-1: Take a single fruit and place it on a circular slab.
- 3 Step-2: The circular slab automatically rotates, and images were captured via the USB camera.
- 4 Step-3: For each fruit, it takes 8 images from different angles.
- 5 Step-4: As the USB camera is connected to the PC, images need to be saved in the respective good fruit and Bad fruit folders.
- 6
- 7 Step-5: The same process is repeated for all the images of good and bad fruits in each fruit category.
- 8

9 **2.4 Machine learning classification**

10 After the dataset collection. the five machine learning models have been taken for the classification of
 11 fruits based on their quality like good or bad. Here good refers to both the ripe and unripe fruits. It is
 12 characterized by the changes in the color, and evenness. Bad quality of fruits refer to rotten and decayed
 13 fruits characterized by abrupt changes in the color, evenness and shape, All the models are supervised
 14 so the training must be done before the classification and testing is performed to determine the
 15 performance of the system. Support vector machine, K-nearest neighbour, Decision tree, Random
 16 Forest, and finally Artificial neural network these are five machine learning models. All the models are to
 17 be tested for the different fruits with different classification strategies.

18
19 **3. RESULTS AND DISCUSSION**

20 This section discusses the distribution of different fruit quality classes, Training, and the performance of
 21 the system. Totally six different fruits quality has been analysed. All the fruits have the training data of
 22 more than 1000 images and out of which 600 images are good quality images and 400 are taken as bad
 23 quality images. The testing dataset consists of 200 images each in each fruit category. Table 1 shows the
 24 different number of fruits and the training testing data distribution. Figure 7 shows the data distribution in
 25 terms of quality classification. The system accuracy was also analysed. Accuracy is defined as the
 26 number of correct predictions made from the total number of predictions.. It is expressed in eqn (1).

$$27 \quad \text{Accuracy} = (Tp + Tn) / (Tp + Tn + Fp + Fn) \quad (1)$$

28 Where, Tp, Tn, Fp and Fn are given as follows.

29 **True positive (Tp)** = Sum of number of Positive sample identified as Positive

30 **False-positive (Fp)** = Sum of number of Negative samples is identified as Negative

31 **True negative (Tn)** = Sum of number of Negative samples identified as Positive

32 **False-negative (Fn)** = Sum of number of Positive samples identified as Negative

33

34

Table 1. Dataset distribution

SI.NO	Fruit / Vegetable	Training(database images)	Testing (no of fruits)

1	Lemon	2581	100
2	Oranges	2969	100
3	Tomato	1652	100
4	Guava	3932	100
5	Pomegranate	1455	100
6	Apple	10978	100

1

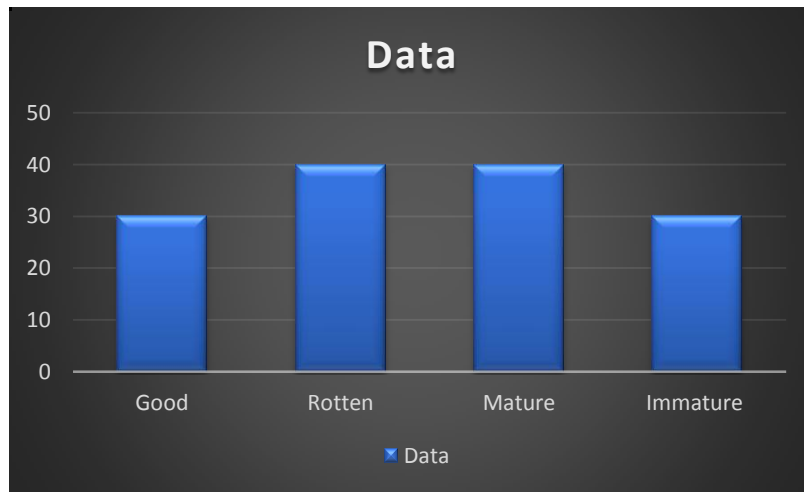

2

3

Figure 7: Fruit Quality Classes

4

5 In terms of response time, the system is low. The compact connections make the system perform faster,
 6 The rotation time of the fruit is one second which means the controller quickly sends the signal to the
 7 motor to capture the input image. It is displayed in Table 2

8

Table 2 Response Time of the system

SI.NO	Scenario	Time (sec)
1	Rotation	42
2	Tilting	3
3	Open/close	5
4	Total	50

9

10 Regarding the cost of the system no additional specific processor is needed, The general purpose
 11 microcontroller Arduino and PIC are needed which is a very low cost. The graphical user interference of
 12 the system is displayed here in figure 8. It is designed using the MATLAB 2019 software.

13

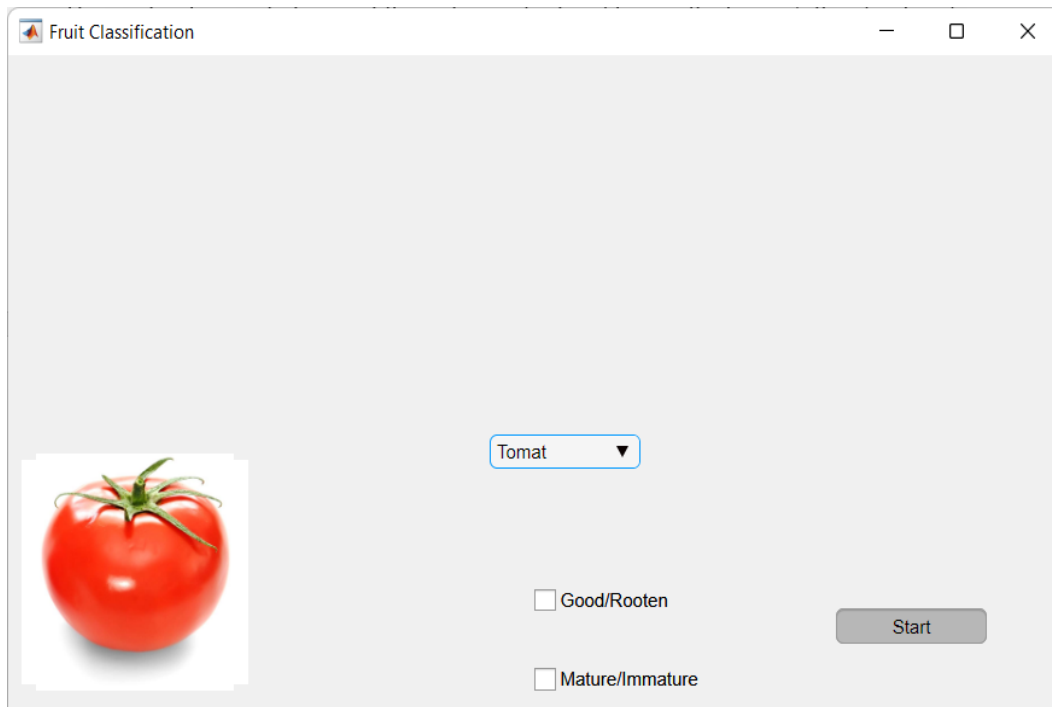

Figure 8: Different fruit classification Initial Screen

Figure 9 shows the initial screen of the developed system. Here the screen is used to select the different fruits and can check the fruit status Good/Rotten or Mature/Immature.

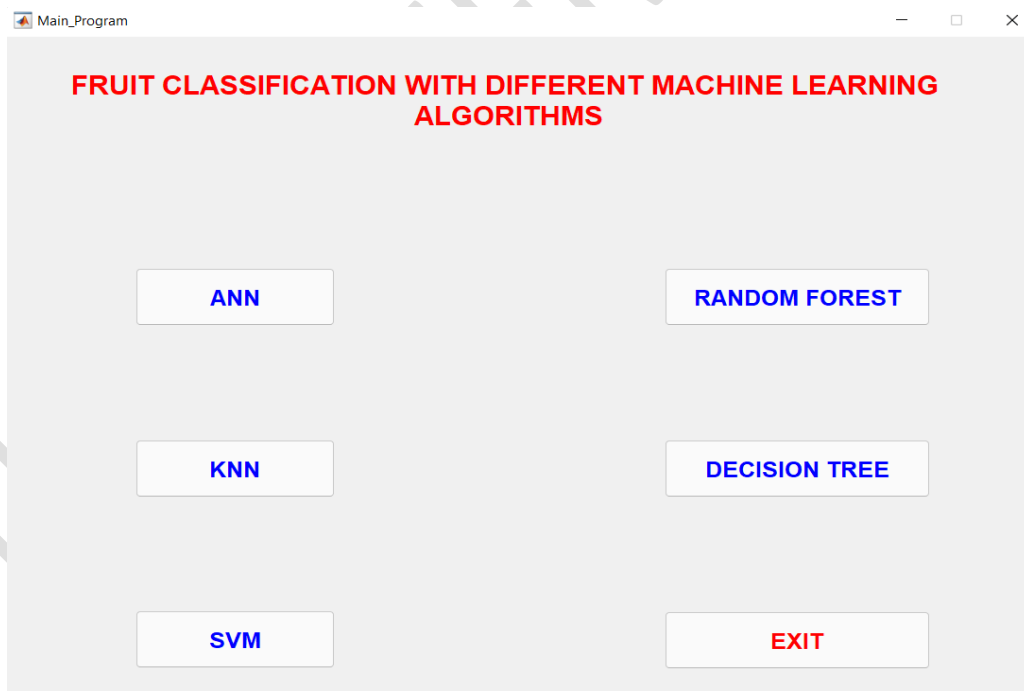

Figure -9 Machine learning Method Display Screen

1
2
3
4
5

6
7
8
9
10
11

1 **Table 3 Comparison of different Methods**

2

Method	Scenario	Time (sec)	Accuracy %
Prabha and Kumar (2013), [30]	Olympus	Not reported	85
Kanade (2014) [31]	Webcam	Not reported	92.6
Yahaya (2015), [32]	LED	Not reported	87.9
Jhawar (2016), [33]	DSC	Not reported	90
Si et al. (2017), [34]	Cannon	Not reported	94
Pereira et al. (2018), [35]	Sony	Not reported	94.7
Our method	Webcam	50	95.6

3
4 Table 3 shows the comparison of different hardware-based systems for image acquisition for fruit
5 classification. Some of the above systems used the light-emitting diode and different types of cameras.
6 The main advantage of our proposed hardware system is the less processing time and good performance
7 in low-resolution images as well. The developed system analyses the quality of the fruit in 50 seconds
8 which is lower compared to other hardware models. So automatically the cost is low no need for any
9 power full expensive camera for image acquisition. So, any small-scale industry can be used the system
10 to analyse the quality of the different fruits even a small farmer can have this portable technology

11
12 **4.0 CONCLUSIONS**

13 Developed a working prototype hardware model of conveyor with PC has been developed and
14 implemented to analyse the fruit quality. The fruit to be inspected is placed on the circular slab and the
15 USB camera captures images and send them to the PC for classification. The classified output after
16 inspection is sent from PC to Arduino microcontroller via serial port. The Arduino Microcontroller sends
17 this digital output to PIC Microcontroller for displaying the classified output on LCD. A classifier gate
18 mechanism is fixed on the conveyor system. This door opens when the detected fruit is bad i.e., rotten or
19 decayed rejects the fruit from the conveyor. This door closes when the detected fruit is good i.e.
20 ripe/unripe and without decay which then travels along the conveyor. Five different machine learning
21 algorithms are used for inspecting the fruit quality whether it is good or bad as well as ripe or unripe, The
22 response time of the system is 5 seconds which is minimal compared to other systems. Regarding the
23 cost of prototype is low as general-purpose microcontrollers are used. So, it will be very suitable and
24 useful for small-scale industries and farmers to grow up their businesses.

25
26 **COMPETING INTERESTS DISCLAIMER:**

27 **Authors have declared that no competing interests exist. The products used for this research are**
28 **commonly and predominantly use products in our area of research and country. There is**
29 **absolutely no conflict of interest between the authors and producers of the products because we**
30 **do not intend to use these products as an avenue for any litigation but for the advancement of**

1 **knowledge. Also, the research was not funded by the producing company rather it was funded by**
2 **personal efforts of the authors.**

4 REFERENCES

5 [1] Tripathi MK, Maktedar DD. A role of computer vision in fruits and vegetables among various
6 horticulture products of agriculture fields: a survey. *Inf Process Agric* 2020;7:183–203.

7
8 [2] Yan B, Wu XH, Ye B, Zhang YW. Three-level supply chain coordination of fresh agricultural products
9 in the Internet of Things. *Ind Manag Data Syst* 2017;117:1842–65.

10
11 [3] Nukala R, Panduru K, Shields A, Riordan D, Doody P, Walsh J. Internet of Things: a review from Farm
12 to Fork. In: *Proc. Proceedings of 27th Irish Signals and*

13
14 [4] Erdenee, B., Ryutaro, T., Tana, G., 2010, Particular Agricultural Land Cover
15 Classification Case Study Of Tsagaannuur, Mongolia. In: *IEEE International*
16 *Geoscience & Remote Sensing Symposium*, 3194-3197.

17
18 [5] Tewari, V.K., Arudra, A.K., Kumar, S.P., Pandey, V., Chandel, N.S., 2013. Estimation of plant nitrogen
19 content using digital image processing. *Int. Commission Agric. Biosyst. Eng.* 15 (2), 78–86.

20
21 [6] Krishna, M., Jabert, G., 2013. Pest control in agriculture plantation using image
22 processing. *IOSR J. Electron. Commun. Eng. (IOSR-JECE)* 6 (4), 68–74.

23
24 [7] Nukala R, Panduru K, Shields A, Riordan D, Doody P, Walsh J. Internet of Things: a review from Farm
25 to Fork. In: *Proc. Proceedings of 27th Irish Signals and Systems Conference*. Londonderry, UK; 2016. p.
26 1–6.

27
28 [8] Dubey SR, Jalal AS. Apple disease classification using colour, texture and shape features from
29 images. *Signal, Image Video Process* 2016;10:819–26.

30
31 [9] Moallem P, Serajoddin A, Pourghassem H. Computer visionbased apple grading for golden delicious
32 apples based on surface features. *Inf Process Agric* 2017;4:33–40.

33
34 [10] Mazen FMA, Nashat AA. Ripeness classification of bananas using an artificial neural network. *Arab J*
35 *Sci Eng* 2019;44:6901–10.

36
37 [11] Tan K, Lee WS, Gan H, Wang S. Recognising blueberry fruit of different maturity using histogram
38 oriented gradients and colour features in outdoor scenes. *Biosyst Eng* 2018;176:59–72.

39

- 1 [12] Silalahi DD, Rean~ o CE, Lansigan FP, Panopio RG, Bantayan NC. Using genetic algorithm neural
2 network on near infrared spectral data for ripeness grading of oil palm (*Elaeis guineensis* Jacq.) fresh
3 fruit. *Inf Process Agric* 2016;3:252–61.
4
- 5 [13] Sabzi S, Abbaspour-Gilandeh Y, Garcí'a-Mateos G. A new approach for visual identification of
6 orange varieties using neural networks and
7
- 8 [14] Jana S, Basak S, Parekh R. Automatic fruit recognition from natural images using colour and texture
9 features. In: *Proc. devLC '17 Proceedings of the 2017 IEEE conference on Devices for Integrated Circuit*,
10 *Kalyani, India; 2017. P. 620–4.*
11
- 12 [15] Li D, Shen M, Li D, Yu X. Green apple recognition method based on the combination of texture and
13 shape features. In: *Proc. ICMA '17 Proceedings of the 2017 IEEE International Conference on*
14 *Mechatronics and Automation. Takamatsu, Japan; 2017. p. 264–9.*
15
- 16 [16] Purohit S, Viroja R, Gandhi S, Chaudhary N. Automatic plant species recognition technique using
17 machine learning approaches. In: *Proc. CoCoNet '15 proceedings of the 2015*
18
19
- 20 [17] Bolle RM, Connell JH, Haas N, Mohan R, Taubin G. Veggie vision: a produce recognition system. In:
21 *Proc. WACV '96 Proceedings of the 1996 IEEE Workshop on Applications of Computer Vision, Sarasota,*
22 *FL, USA;*
23 *1996. p. 244–251.*
24
- 25 [18] Nosseir A, Eldin S, Ahmed A. Automatic identification and classifications for fruits using k-NN. In:
26 *Proc ICSIE '18 Proceedings of the 2018 ACM international conference on software and information*
27 *engineering Cairo, Egypt; 2018. p. 62–67.*
28
- 29 [19] Choi D, Lee WS, Ehsani R, Schueller J, Roka FM. Detection of dropped citrus fruit on the ground
30 and evaluation of decay stages in varying illumination conditions. *Comput Electron Agric* 2016;127:109–
31 19.
32
- 33 [20] Kumar RA, Rajpurohit VS, Nargund VB. A neural network assisted machine vision system for sorting
34 pomegranate fruits. In: *Proc. ICECCT '17 Proceedings of the 2017 Second International Conference on*
35 *Electrical, Computer and Communication Technologies. Coimbatore, India; 2017.p. 1–9.*
36
- 37 [21]Singh N, Dubey SR, Dixit P, Gupta JP. Semantic image retrieval by combining colour, texture and
38 shape features. In: *Proc. ICCS '12 proceedings of the 2012 IEEE international conference on computing*
39 *sciences. Phagwara, India; 2012. p. 116–120.*
40

- 1 [22] Lakooju N. K., Gudla S., and Mantravadi B. S., (2011). AVR-USB Data Acquisition. 2nd National
2 Conference on Information and Communication Technology, 3, 35 - 39.
3
- 4 [23]Rautu, S. V., Shinde, A. P., Darda, N. R., Vaghule, A. V., Meshram C. B. and Sarawade, S. S.
5 (2017). Sorting of objects based on colour, weight and type on a conveyor line using PLC. IOSR Journal
6 of Mechanical and Civil Engineering, e-ISSN: 2278- 1684,p-ISSN: 2320-334X, 4-7.
7
- 8 [24] Sheela.S, Meghashree. S., Monica. L., Prathima, A., and Shriya, M. K (2016). Automation For
9 Sorting of Objects Using Raspberry PI 3. International Journal of Advances in Electronics and Computer
10 Science, ISSN: 2393.
11
- 12 [25] DharmannagariVinay Kumar Reddy, Sorting Of Objects Based On Colour By Pick And Place
13 Robotic Arm And With Conveyor Belt Arrangement, International Journal Of Mechanical And Robotics
14 Research, ISSN 2278 – 0149, January 2014.
15
- 16 [26] Kunhimohammed C. K, MuhammedSaifudeen K. K, Sahna S, Gokul M. S And ShaezUsman
17 Abdulla, Automatic Colour Sorting Machine Using TCS230 Colour Sensor And PIC Microcontroller,
18 International Journal Of Research And Innovations In Science & Technology, ISSN (Online): 2394-3858,
19 2015
20
- 21 [27] Prof. NilimaBargal, AdityaDeshpande, RuchaKulkarni, RuchaMoghe, PLC based Object Sorting
22 Automation, International Research Journal Of Engineering & Technology, ISSN (Online): 2395-0056,
23 July 2016
24
- 25 [28] Sheela S, Shivaram. K. R, Meghashree S, Monica L, Prathima A, Shriya M. Kumar, Low Cost
26 Automation for Sorting of Objects on Conveyor Belt, International Journal Of Innovative Research in
27 Science, Engineering & Technology, ISSN (Online): 2319-8753, May 2016
28
- 29 [29] Ganesh B. Shinde, Vishal P. Ghadage, Akshay A. Gadhave, Dr. D. K. Shedge, PLC Based Auto
30 Weighing Control System, International Journal Of Engineering And Technical Research (IJETR), ISSN:
31 2321-0869.
32
- 33 [30] Prabha, D.S., Kumar, J.S., 2013. Assessment of banana fruit maturity by image processing
34 technique. J. Food Sci. Technol.
35
- 36 [31] Kanade and A. Shaligram, "Development of machine vision based system for classification of Guava
37 fruits on the basis of CIE1931 chromaticity coordinates," 2015 2nd International Symposium on Physics
38 and Technology of Sensors (ISPTS), 2015, pp. 177-180, doi: 10.1109/ISPTS.2015.7220107.
39

1 [32] O. K. M. Yahaya, M. Z. MatJafri, A. A. Aziz and A. F. Omar, "Non-destructive quality evaluation of
2 fruit by colour based on RGB LEDs system," 2014 2nd International Conference on Electronic Design
3 (ICED), 2014, pp. 230-233, doi: 10.1109/ICED.2014.7015804
4
5 [33] Jhawar, J., 2016. Orange Sorting by applying pattern recognition on colour image. Int. Conf. Inf. Sec.
6 Privacy, 691–697.
7
8 [34] Si, Y., Sankaran, S., Knowles, N.R., Pavek, M.J., 2017. Potato Tuber Length-Width ration
9 assessment using image analysis. Am. J. Potato 94 (1), 88–93.
10
11 [35]Pereira, L.F.S, Jr, S., B., Valous, N.A., Barbin, D.F., 2018, Predicting the ripening of papaya fruit with
12 digital imaging and random forests. Computers and Electronics in Agriculture, 145, 76–82.
13 1.
14

UNDER PEER REVIEW