

# **Original Research Article**

## **Centric Data Analytics Framework for Solar Energy Efficiency in the rural settings**

### **Abstract**

Climate change periodically, and one of its natural causes is solar variation. Solar energy generation is now gaining more attention in developed nations, and its usefulness is becoming acceptable in rural settings. This research focused on Centric Data Analytics Framework for Solar Energy Efficiency called DAFSEE to solve power supply deficiency *in resource-limited settings in Kwara State*. Statistically, resource-limited regions feature a low population with a shortfall of social amenities. Significantly, households in urban areas have more electricity consumption than rural ones, making solar energy more relevant. The researcher then determined the efficiency of solar energy in the selected regions over time using an experimental study using cloud computing to create a dataset in six geo-locations in Kwara State. A predictive model was adopted and yielded 98.99% from the recurring analytics of the installed solar cells. The outcome of this study suggested best practices to sustain renewable energy in the area across all seasons. The study provides a starting point to distil policy implications for a centric analytics framework of improving rural electrification relevant for collective resource-limited settings across Nigeria.

**Keywords:** Centric Data, Energy Efficiency, Solar Energy, Solar Cells

## **Introduction**

Climate change results from natural phenomena and the nature that affect the changes that cannot be eliminated but can be studied [1]. Many researchers have published many research works on the trends of environmental change that have influenced solar energy. These environmental changes now are categorized into two, climate change and solar radiation [2]. People living in some Local Government Areas (LGA) in Kwara State, Nigeria, have been facing down trends of electrification credit facilities in the seventeen (17) LGA(s) in the State. The bottleneck in the line of grid expansion poses significant challenges in rural settings because of the rapidly growing population. Rural Settlement all over Nigeria suffers from an overwhelming deficit in access to reliable electricity [3]. The use of non-renewable energy resources is significantly low in a low resource settings compared with mega-cities [4]. While the impact of using renewable resources for producing electricity is increasing in developed countries [5].

The problem in mind according to the researcher is that; the radiant energy from sunlight has proven not efficient in the research domain, provided that household energy consumption is high compared with available energy generated from solar cells. However, the shortfall of energy consumption affects social life in the rural settings, and this determines the needful to decide on the quantity of energy required for the sustainability the livelihood. This study is viable for future analytics and assists renewable vendors and stakeholders in deciding on electrification capacity that would fit rural settlements. This Possibilities to provide an alternative to shortfall grid supply will be visible and accepted in the results followed by stakeholders. To analyse whether the DAFSEE result is efficient and can generate sufficient solar radian (energy), therefore can improve the sustainability of rural electrification using mini and micro sub-stations if adequately implemented in the villages.

However, this research aims to examine the efficiency of solar energy in a resource-poor environment over time, determine how rural sentiment can rely on solar energy as an alternative to the grid system, and use a research design model to predict sustainability and efficiency. Solar panels are becoming increasingly popular around the world. The people living in resource-poor environments might see the long-term benefit due to poor user experience and lack of technical know-how [2], [5]. Research is responsible for determining factors impeding sustainability with the real-time radiant energy monitoring approach in some regions of Kwara State. This required forensic analysis through laboratory experiments in the research study and a few supervised ethics tests to produce results.

Rural power generation in Nigeria is unsustainable, and energy demand is increasing rapidly. The power supply from rural and metropolitan areas is not always sustainable and targeted. In general, the cause of inefficiency in a power distribution network is that electrification is fairer in a metro area than in a rural area. In rural areas, electrification of the power supply has become increasingly difficult. As a result, many households are looking for alternative energy sources to make up for the deficit. In addition, there is growing concern about the number of greenhouse gases emitted from fossil fuels. However, due to the numerous advantages, green energy is preferred [5]. An advantage of green or renewable energy is that it is sustainable, which implies efficient use of sustainable energy sources with minimal environmental impact and better socio-economic acceptability [6, 7]. Renewable energy sources that can replace fossil fuels include hydropower, which has associated negative consequences such as B. the problem of flood vulnerability to seasonal water level fluctuations and so on. These problems are discussed in detail in [8]. This thus underlines why solar energy is preferred as an alternative energy source in rural areas as an alternative energy source. In addition, due to its location in a tropical region, Nigeria has enormous potential for solar energy [9].

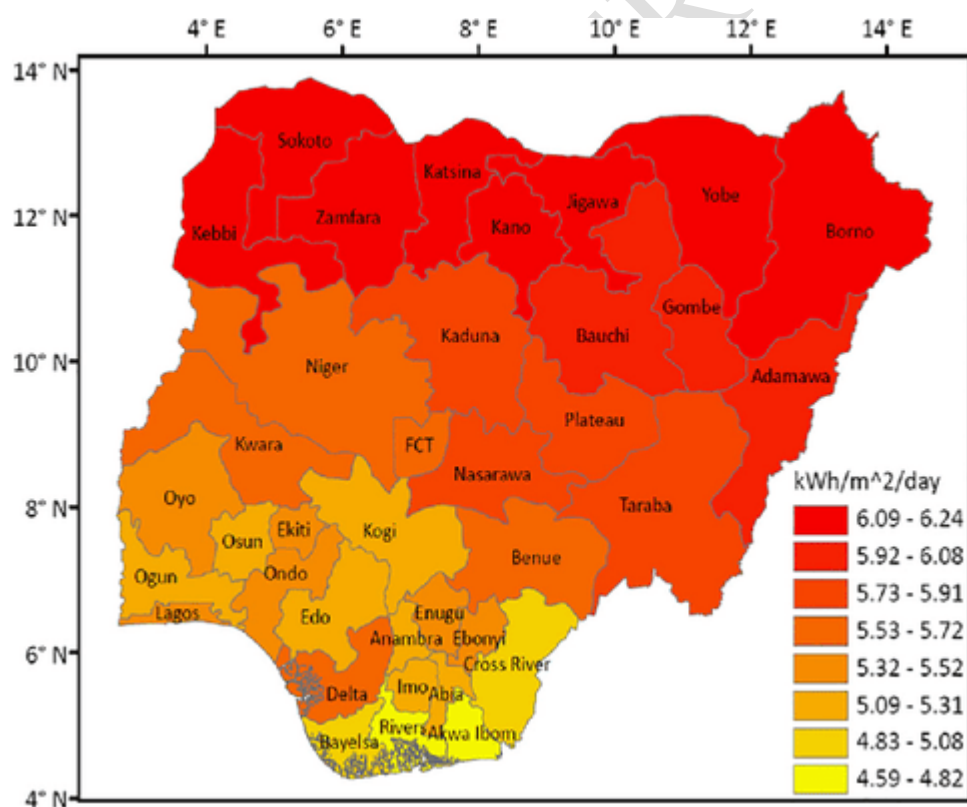


Figure 1: Solar radiation map of Kwara State

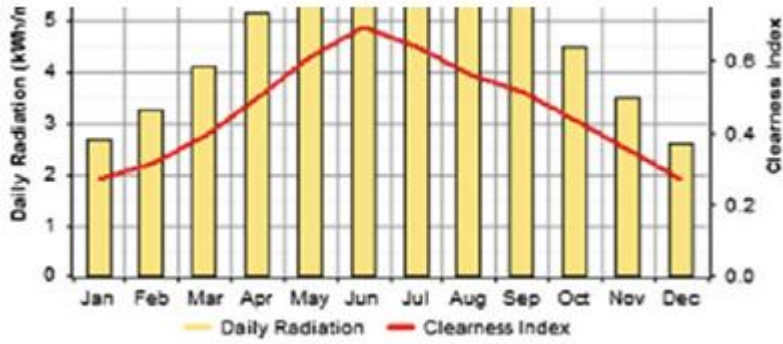


Figure 2: Average monthly Solar profile. Source <https://eosweb.larc.nasa.gov/sse/RETScreen/>

This study highlights the solar irradiance map in Figure 1 with deviation of 5.53 to 5.52. The average amount of direct and diffuse solar radiation in Asa, Isin, Offa, Oyun, Irepodun, and Oke Ero in Kwara State in north-central Nigeria is shown in Figure 2.

UNDER PEER REVIEW

## 2.0 Literature Review

The solar panels generate direct current by radiating energy from sunlight. The fuel form is then converted into electrical energy and stored selectively in an accumulator [9]. Centric Data Analytics is now gaining global acceptance as industries and organizations look inward at how digitization is being leveraged and transforming the product line for businesses. Data collection is one of the essential requirements for potential solar areas; Most data span 3040 years, and using unit root and Johansen cointegration tests with low data points provides low statistical test performance [10]. The advanced analysis using total factor productivity in African manufacturing is considered to examine the relationship with infrastructure in the six local government areas in Kwara State [11]. Looking at the author's overview for a recent review of renewable electricity support mechanisms, the World Bank uses several criteria to support electrification projects. These include cost-effectiveness of connection, distance to a power grid, affordability and population density.

However, as illustrated by the example of the villages around Abuja, Nigeria, the actual value of providing efficient solar energy in a place with off-grid technology lies in its ability to draw on local resources and contribute to the development of local potential [12]. 2.67 million According to the 2006 census, households in Kwara state have no access to electricity, resulting in an overall electrification rate of about 33 percent. The access rate for a home in urban settlements suffers from insufficient network coverage of about 3-5 hours of uplink in 24 hours, which worsens the economic situation. The access deficit is evident in rural areas in all seventeen local governments in Kwara State, such as B. Offa, Irepodun, Oyun, Asa and others, as shown in Table 1. Furthermore, considering the variations and patterns of energy consumption, household access to electricity varies significantly in the rural areas (villages and hamlets) with over one million inhabitants in the target 6 LGA [13].

Selected six Local Government Area on Study		
Asa	Isin	Offa
Oyun	Irepodun	Oke Ero

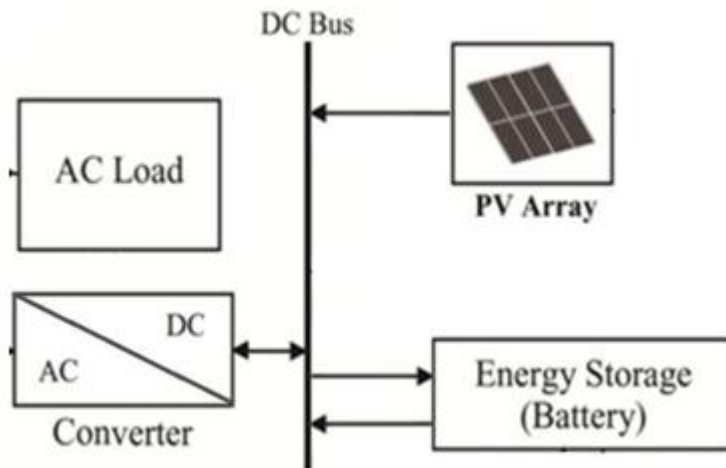
**Table 1: Selected LGA study**

The off-grid substation for rural electrification is not emerging in Kwara compared to states like Lagos, Lokoja, Kogi, Port Harcourt, Enugu and others. However, few households in urban areas have adopted renewable energy as an alternative energy source. Solar radiation is very high and varies between all municipalities in the target state. Researchers use the

variance to determine the opportunities for efficient use of photovoltaic technology to generate electrification in the sub-regions under each local government [14]. These sub-regions are target areas, and the study used the region when required to implement off-grid coverage or use it as a natural alternative to grid coverage. Utilizing the energy stored in batteries is a key factor that determines the efficiency of solar in the target region.

Uganda leads African countries with well-developed power regulatory frameworks - ERI 2020 report Nigeria remains bottom end in power frameworks. Energy demand will increase by 200% from FY 2015 to FY 2030 [15]. To meet these growing demands, the use of renewable energy sources such as solar and wind is therefore of crucial importance. Only 45,917 MW of renewable energy has been installed and used. Business providers in Nigeria are expected to target 175 GW worth of renewable energy installation by the end of 2022 [9]. The use of these renewable energy sources is becoming more and more extensive, attractive and cost-effective. But the unpredictability and dependence on climatic changes impede the proper use of these resources. Due to the reliance on variable hours of sunshine and changing wind speeds, these resources do not produce productive energy year-round [16]. However, by mixing two or more energy resources, these problems can be mitigated. Fig. 4 shows the block diagram of a hybrid renewable energy system. In this system, solar power is the input, and a battery is the backup power source when power is unavailable. A diesel generator can power the load when solar and wind power are unavailable. It can also take on the load during peak hours.

Many renewable energy systems have been installed in the last decade, resulting in new technologies that challenge traditional energy systems. Many works on renewable energy have been carried out in recent years, including developing efficient converters, maximum power point trackers (MPPT), improved batteries and the optimal design and control of renewable energy systems [17].



**Figure 3. Concept of Solar energy system**

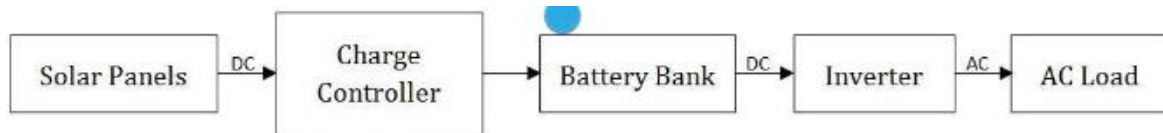
## **2. Pre-feasibility analysis of solar energy systems**

The climatic conditions determine the availability of solar energy resources in that particular location. Pre-feasibility studies depend on climatic data such as wind speed, solar radiation and load requirements for that specific site. Appropriate weather data is required to calculate the performance of a system. Weather conditions may vary from location to location. The advantage of hybrid energy systems lies in the simultaneous use of several sources, which increases the system's overall efficiency. The weather patterns in different locations play an essential role in the planning and implementation the solar-wind hybrid energy system. Many researchers consider station metrological data for pre-feasibility studies, design and optimization of renewable energy systems. The feasibility and performance studies validated studies evaluating hybrid PV wind energy system options; a flagellated approach to study the feasibility of hybrid PV wind energy systems using artificially collected solar irradiance and wind speed data [5,18].

## **3. Photovoltaic system**

therefore, it contributes to reducing greenhouse gas emissions [19],[20]. Solar energy uses either solar photovoltaic (SPV) or solar thermal technologies. In a solar PV system, solar radiation from the sun is converted into electricity using solar cells. The most commonly used materials for PV cells are mono- and polycrystalline silicon. Solar energy is used to provide electricity in off-grid or grid-interactive mode. Name of solar PV technology devices used in various fields such as rooftop solar panels, telecom, transportation, refrigeration, and especially in long-distance and rural electrification. An off-grid solar PV system, shown in Fig, includes many solar panels, a charge controller, a battery bank, and an inverter to service

the AC load. MPPT trackers extract the maximum power from the solar panels [20]. The charge controller is essential for battery management and prevents overcharging and deep discharging of the battery. The inverter converts DC to AC to power the AC load.



**Figure 4. Block diagram of off-grid solar PV system**

In order to use the maximum performance of the solar panels, a suitable site selection is required to carry out feasibility studies such as technical and economic feasibility [15]. Researchers have also proposed solar energy artefact modelling involved in the techniques. [21,22] The productive lifetime of solar modules and the power generation from installed modules over time depends on factors such as climate, module type and shelving system, among others. The Syahputra study found that the decrease in the performance of solar panels over time is called degradation. This study showed that solar panels have an average degradation rate of about 0.5% per year, but the rate could be higher in hotter climates and roof systems[23,24,26]. A degradation rate of 0.5% implies that the production of a solar module decreases by 0.5% per year. This means that in year 20, the module produces about 90% of the electricity to be released in one year.

### **3.1 Methodology**

The research team used a methodological approach to increase the validity of the data collected in the evaluation's findings, conclusions, and recommendations. Data sources included information drawn from the researcher's visibility study and analysis of the experiment outcome. Meeting with research informants with implementation in study site; the researchers, together with a coresearcher visit to the selected rural areas under six local Governments, then facilitated 100W solar mini-grid site in Offa, Ijagbo, Oro, Omupo, Gannan in Kwara State. The study examined secondary data in the department of Mechanical Engineering (ME), Federal Polytechnic Offa, and primary data collected during the evaluation (qualitative). The data availability provided an overall picture of the achievements of the activity of the researchers. Hence, quantitative (managed by the research activities between January to December 2021). The research team prepared laboratory tests from the artefact produced and used protocols as part of its method approach to actualise better results.

### **3.2 Types of solar panel rotation array mountings**

This is the simplest and least expensive type of solar panel mounting system suitable for this study, it will be fully automated. The solar panels should always be aligned in the direction of the sun. A typical way of mounting solar panels is shown in Figure 3.

**Auto-Tracking:** This solar panel, when mounted, follows the path of the sun during the day to maximize solar irradiance, allowing the solar panels to receive maximum energy from sunlight and the sun's seasonal declination movement.

### 3.3 Parameters for setting up artefact prototype

The setup system for this study experiment includes the main board (Arduino Mega), wood and acrylic materials and sensor modules. The module sensor has two steering gears and four photosensitive modules. Part of the sensor modules includes solar panels, intelligent phone charging, light intensive module, I2C1602 module, two-way control buttons, lithium battery, passive buzzer, temperature and humidity sensors, and photoresistor.

Hence, the parameter for setting up the system as follow;

Artefact Working voltage: 5V Input voltage: 3.7V

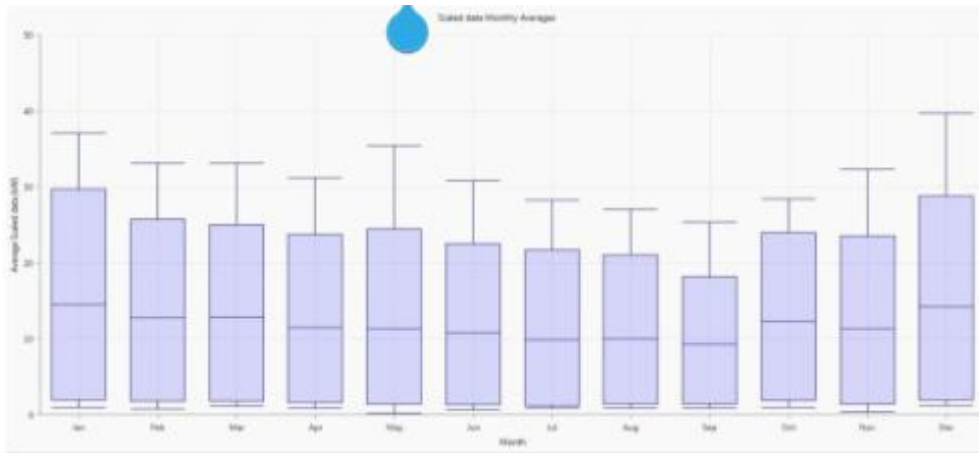
Maximum output current: 1.5A

Maximum power dissipation: 7.5W

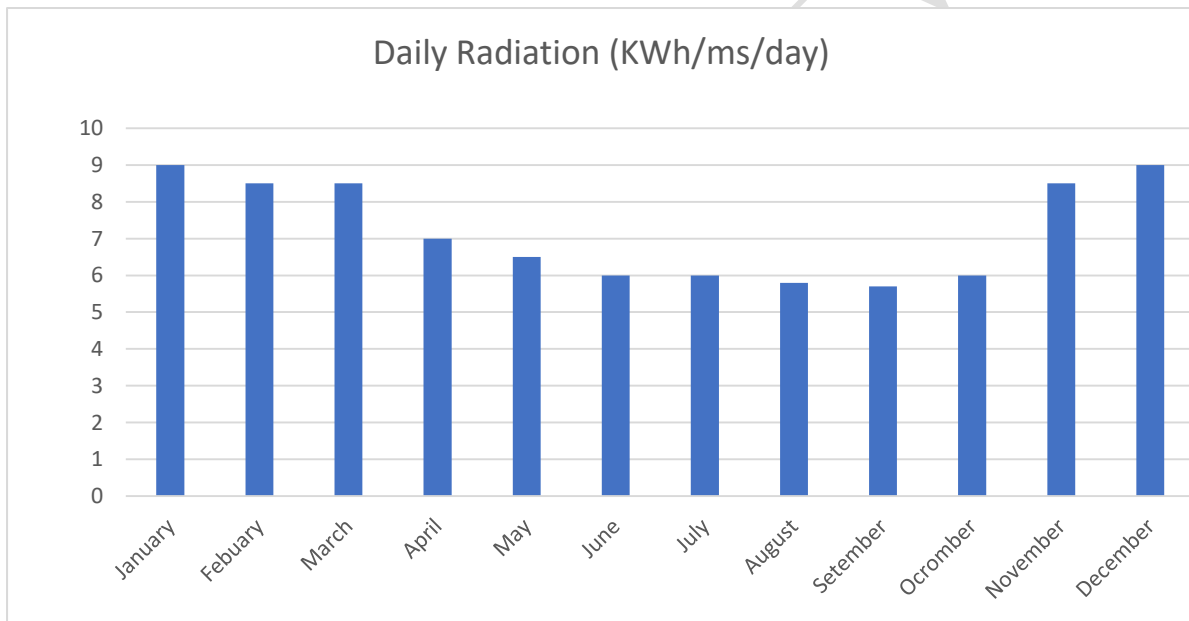
## 4. Centric Analytic framework results and Discussion

The study presents the Centric Analytic Framework (CAF) in Fig.1. The model system was designed and modelled in the Optimization Model for Electric Renewable (HOMER) platform. The modelling methodology includes site identification, load identification and resource assessment, technology selection, system constraints, optimization and economic analysis [23,25]. First, the geographic details of the proposed location remain centralized. The energy demand of the selected area is further estimated after the energy demand calculation, potential assessment and technology selection of the renewable energy sources in the proposed and studied area. Then the system components' mathematical model is developed, including renewable energy sources such as solar and wind, load demand, energy storage system and converter. Finally, the model is optimized to develop an optimal model for the energy supply at the study site. The study was conducted at Offa and Ijagbo, Kwara, at latitude and longitude 8.1393N and 4.7174E, respectively. In this study, the approximate measured average annual consumption was 282.76 kWh/day with a peak load of 39.65 kW. Fig. 3 shows the monthly average load profile. Fig. 4 shows the mean yearly insolation and lightness index for the proposed site and is estimated to be 5.34 kWh/m<sup>2</sup> and 0.619,

respectively. The average wind speed is about 4.73 m/s, measured at an anemometer height of 50 m.

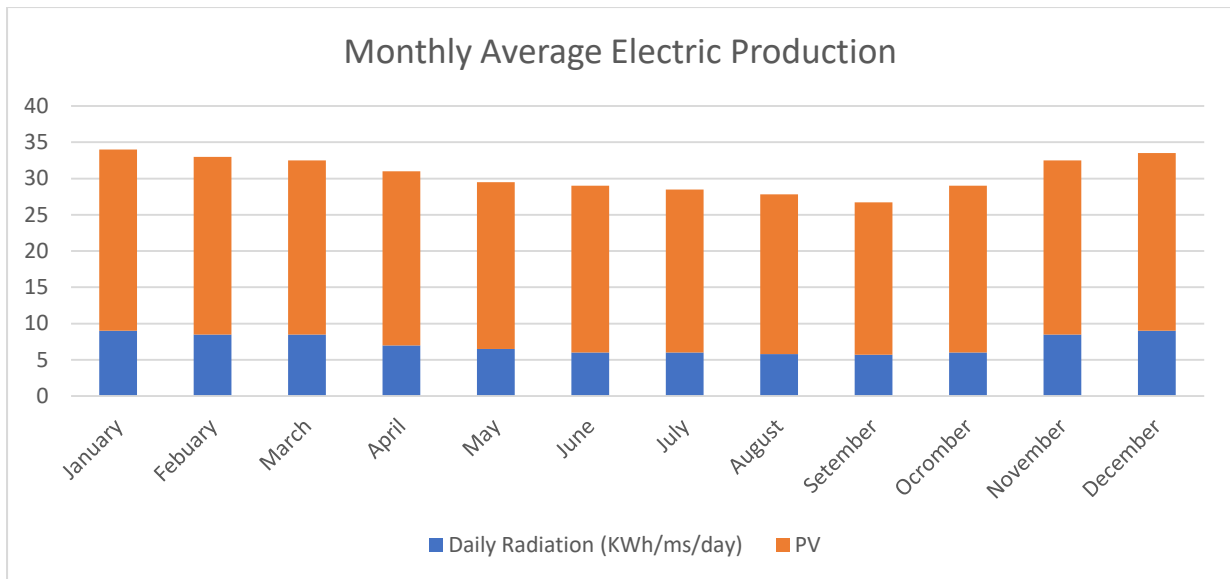


**Figure 5. Average monthly load demand**



**Figure 6. Average daily solar radiation and clearness index**

Kwara State in Nigeria is endowed with abundant renewable energy sources such as solar, wind and hydropower. For example, for solar energy, there is an average solar radiation of 5.25 kWh/m<sup>2</sup>/day, which might meet the entire national household energy demand if harnessed. In figure 4 above, the radiation starts decreasing from April till September. The rising pattern begins in October and down to the end of the year. Right from January, the energy radiation has proven to be very high, just like in November - December. It follows a rising edge till late in March. The experiment set shows an average voltage drop 15Volt reading from the multimeter from May to September. Monthly average electricity production of renewable energy system shown that daily radiation in figure 5.



**Figure 7.** Monthly average electricity production of renewable energy system

Figure 7 shows a different source's contribution to a rural area's power supply. The study investigation considers the periodic availability of electrification in the research domain. The up time and down time in the supply of grid electrification are measured over time and represented in blue bars shown in figure 5. Hence, the orange bars combined in the chart indicate the energy generation from solar PV. The most optimal system among the two generating sources; is a conventional plant generator and solar PV. Grid electrification in rural accumulate 30% of the distribution; Solar energy contributes 70%, and a power grid system generator fulfils the rest demand.

### Challenges and future scope

Currently, the research is identifying the use of coal to generate electricity in Off/ Ijagbo despite being slim. However, it is finite, non-renewable and emits enormous CO<sub>2</sub> causes massive CO<sub>2</sub> emissions that contribute to global warming. So using renewable energy resources alone or mixing them with other aid power generate power tools can reduce CO<sub>2</sub> emissions [16],[17]. However, there are several challenges when deploying renewable energy systems. The study has achieved a lot in recent years and gained a lot. However, there are still specific challenges in the selected region regarding their efficiency and optimal performance. Renewable energy sources require cutting-edge technology and the latest technology to harness and harness the maximum helpful power, which is a significant barrier to harnessing the amount of valuable energy. The main obstacle to using solar photovoltaics is their poor efficiency. The efficiency of the experiment will be improved by using efficient materials for the solar cell artefact. The grid interconnection power quality of the grid connection of the renewable energy systems is of great significant importance and needs frequent cooperative

R&D requires collaborative research and development. The switching losses associated with power electronic converters should be minimal. The capital cost of renewable energy sources is a significant problem that needs an issue that deserves serious attention. The affordable usage of cane may eventually allow residents in rural settings to take advantage of such systems. Future, leading cutting-edge technology development is required to increase the overall efficiency of hybrid energy systems. The suggested deployment of hybrid renewable energy systems will circumvent the energy issues problems and ensure a clean and generations return in the region.

## **5. Conclusion**

In this paper, a Centric Data framework with the solar component is designed and implemented for a rural site to meet the research goals. The economic analysis of the proposed system enables the adaptive tracking feature's window reality of the adaptive prototype model. However, the problems related to efficiency, power quality, stability and economy have hampered using non-sustainable grid system resources. Future research and development efforts can solve these problems by implementing renewable energy systems in rural settlements. Though, hybrid renewable energy sources have immense potential to meet the requirement in the season where energy retention in the solar panels decreases over time in the study region. However, using an energy consumption pattern coupled with load factor could help sustain the efficiency over time. The amount of energy stored in the study area could increase energy needs and create a sustainable future.

## **ACKNOWLEDGEMENTS**

The authors acknowledge the support of Nigerian Tertiary Education Trust Fund (Tetfund) through its Institution Based Research Grant (Merged year 2019 -2021 merged, 8<sup>th</sup> batch RP) that made the study possible.

## **COMPETING INTERESTS**

Authors have declared that no competing interests exist.

## **AUTHORS' CONTRIBUTIONS**

Olaboye Y. conceived of the presented idea. Abikoye E. O. developed the theory and performed the computations. C.D. and Alabi A. O. verified the analytical methods, then investigated the study site on Federal Polytechnic offa for this study and supervised the findings of this work. All authors discussed the results and contributed to the final manuscript.

## Reference

- [1] Iwuoha, Augustine U., and Briggs M. Ogunedo. "Performance Evaluation and Economic Analysis of a Domestic Solar Cooker." *Open Access Library Journal* 8.3 (2021): 1-15.
- [2] Goyal, Nihit. "Explaining Policy Success Using the Multiple Streams Framework: Political Success Despite Programmatic Failure of the Solar Energy Policy in Gujarat, India." *Politics & Policy* (2021).
- [3] Bose, Debajyoti, et al. "Decentralized Solar Energy Access and Assessment of Performance [] Parameters for Rural Communities in India." *Sustainability and Climate Change* 14.2 (2021): 103-114
- [4] S. Jain and V. Agarwal, "An integrated hybrid power supply for distributed generation applications fed by non conventional energy sources", IEEE Transactions on Energy Conversion, Vol. 23, No. 2, pp. 622- 631, (2008).
- [5] Tidwell, Jacqueline Hettel, and Abraham Tidwell. "Decarbonizing via disparities: Problematizing the relationship between social identity and solar energy transitions in the United States." *Energy Research & Social Science* 77 (2021): 102099.
- [6] Abikoye, O. E., C. O. Adeyinka, and Y. O. Olaboye. "EVALUATION OF SOLAR POWERED WATER PUMPING SYSTEM." *The Ninth International Conference on Applications of Information Communication Technologies to Teaching, Research and Administration*.
- [7] Ehiagwina, Frederick Ojiemhende, et al. "DEVELOPMENT OF A SOLAR ENERGY TRACKING MECHANISM WITH ARTIFICIAL NEURAL NETWORK ENHANCEMENT."
- [8] Kehinde, Olufemi Olusola, et al. "Photovoltaic cell output voltage variations with time and inclination angle." *IOSR J Electr Electron Eng* 11 (2016): 40-47.
- [9] Afolabi, L. O., et al. "Prediction of solar radiation patterns for sustainable implementation of solar power generation." *Ann. Fac. Eng. Hunedoara* 15 (2017): 153-160.
- [10] N.A. Ahmed and M. Miyatake, "A stand-alone hybrid generation system combining solar photovoltaic and wind turbine with simple maximum power point tracking control", Proceedings IEEE IPEDMC, pp. 1-7, (2006).
- [11] E. Koutroulis, K. Kalaitzakis and N.C. Voulgaris, "Development of a microcontroller-based photovoltaic maximum power point tracking control system", IEEE Transactions on Power Electronics, Vol. 16, No. 1, pp. 46-54, (2001).
- [12] Lemence, Allen Lemuel G., and Mili-Ann M. Tamayao. "Energy consumption profile estimation and benefits of hybrid solar energy system adoption for rural health units in the Philippines." *Renewable Energy* 178 (2021): 651-668.
- [13] V. Khare, S. Nema and P. Baredar, "Status of solar wind renewable energy in India",

Renewable and Sustainable Energy Reviews, Vol. 27, pp. 1-10, (2013).

Hybrid Optimization Model for Electric Renewable (HOMER).

Available at <http://www.homerenergy.com>

[14] M. Arifujjaman, M.T. Iqbal, J.E. Quaiocoe and M.J. Khan, "Modeling and control of a small wind turbine", Proceedings of Canadian Conference on Electrical and Computer Engineering, pp. 778-781, (2005).

[15] A. Chauhan and R.P. Saini, "Renewable energy based off-grid rural electrification in Uttarakhand state of India: Technology options, modeling method, barriers and recommendations", Elsevier's Renewable and Sustainable Energy Reviews, Vol. 51, pp. 662-681, November (2015).

[16] Zolkapli, M., et al. "High-efficiency dual-axis solar tracking development using Arduino." *2013 International Conference on Technology, Informatics, Management, Engineering and Environment*. IEEE, 2013.

[17] K. **Joshi**, A. Ashok, S. Chandel, "Optimal Economic Analysis of Hybrid Renewable Energy System", Proceedings IEEE ICACCA (Spring), April 8-9, (2016), Dehradun, India.

[18] M.J. Khan and M.T. Iqbal, "Pre-feasibility study of stand-alone hybrid energy systems for applications in Newfoundland", Renewable Energy, Vol. 30, No. 6, pp. 835-854, (2005).

[19] NASA Surface Meteorology and Solar Energy [Online]. Available at <http://eosweb.larc.nasa.gov/sse/>, Wind Power in India, Wikipedia, the Free Encyclopedia.

[20] Roth, Lucas, Özgür Yildiz, and Jens Lowitzsch. "An Empirical Approach to Differences in Flexible Electricity Consumption Behaviour of Urban and Rural Populations—Lessons Learned in Germany." *Sustainability* 13.16 (2021): 9028.

[21] A.N. Celik, "The system performance of autonomous photovoltaic-wind hybrid energy systems using synthetically generated weather data", Renewable Energy, Vol. 27, pp. 107-121, (2002).

[22] Raza, Muhammad Yousaf, Muhammad Wasim, and Muhammad Sohail Sarwar. "Development of Renewable Energy Technologies in rural areas of Pakistan." *Energy Sources, Part A: Recovery, Utilization, and Environmental Effects* 42.6 (2020): 740-760.

[23] Syahputra, Ramadoni, and Indah Soesanti. "Renewable energy systems based on micro-hydro and solar photovoltaic for rural areas: A case study in Yogyakarta, Indonesia." *Energy Reports* 7 (2021): 472-490.

[24] Daher, Doha Hassan, Léon Gaillard, and Christophe Ménézo. "Experimental assessment of long-term performance degradation for a PV power plant operating in a desert maritime climate." *Renewable Energy* 187 (2022): 44-55.

[25] Al-Shahri, Omar A., et al. "Solar photovoltaic energy optimization methods, challenges and issues: A comprehensive review." *Journal of Cleaner Production* 284 (2021): 125465.

[26] Shahabuddin, M., et al. "A critical review on the development and challenges of concentrated solar power technologies." *Sustainable Energy Technologies and Assessments* 47 (2021): 101434.

UNDER PEER REVIEW