

---

# Artificial Neural Network and Its Application Research Progress in Chemical Process

**Abstract:** Most chemical processes, such as distillation, absorption, extraction, and catalytic reactions, are extremely complex processes affected by multiple factors. As a result, the relationships between their input and output variables are non-linear, and it is not easy to optimize or control them using traditional methods. Artificial neural network is a systematic structure composed of multiple neuron models. By simulating many basic functions of the nervous system of living organisms, nonlinear control can be realized without relying on mathematical models, and it is especially suitable for more complex control objects. This article will introduce artificial neural networks' basic principles and development history, and review its application research progress in chemical process control, fault diagnosis, and process optimization.

## 1. Introduction

Any product in a chemical plant has to undergo a series of chemical processes such as reaction and separation. In addition, there are many batch or semi-continuous processes with different dangerous conditions such as high temperature and high pressure [1-3]. As the scale of chemical production equipment continues to expand and the degree of automation continues to increase, people have higher and higher requirements for the accuracy and sensitivity of the performance control of industrial processes. However, traditional control technology has difficulty in meeting these requirements. As an important branch of artificial intelligence, the artificial neural network has been widely used in chemical production with intelligent characteristics

---

such as self-adaptation and self-learning, providing practical solutions for the precise and rapid control of complex production equipment. Specifically, artificial neural networks are mainly used in chemical process: such as fault diagnosis, control and optimization of process parameters, product quality control and physical property estimation[4-6]. This article will introduce the principle and development history of the artificial neural network, and summarize its application research progress in chemical process control, fault diagnosis and process optimization.

## 2. Principles and Development History of Artificial Neural Networks

The artificial neural network imitates the human brain neuron network and abstracts it, and then establishes a certain mathematical model, and processes information by adjusting the interconnection weights between a large number of nodes in the model [7,8]. It has self-adaptive and self-learning functions, and is especially suitable for complex nonlinear information processing systems. For example, when the input value is  $x_i$  ( $i=1,2,\dots,n$ ), the output is  $y$ , and the relationship between  $y$  and  $x_i$  is:

$$y = f(s_j) \quad (1)$$

$$s_j = \sum_{i=1}^n w_{ji}x_i - \theta_j \quad (2)$$

where  $\theta_j$  is the bias, and  $w_{ji}$  is the interconnection weights. The output function  $f$  has many forms, and the common ones are: proportional function, quadratic function, hyperbolic function, m-type function, Y-type function, etc.

Each node in the neural network has a state variable. For example, the

---

connection weight coefficient  $w_{ji}$  connects node  $i$  and node  $j$ , and each node has a bias  $\theta_j$  and a nonlinear transformation function  $f$ .

The neuron biology model (M-P model) proposed by McCulloch and Pitts [9] and the Hebb rule proposed by Hebb [10] can be regarded as the beginning of artificial neural networks. The groundbreaking papers of Hopfield [11-13], Kauffman [14], LeCun [15,16] and Hinton [17-19] are the theoretical basis for artificial neural networks to mature. They are ubiquitous in modeling neural and gene networks, and they are also indispensable tools in computer science. Hodgkin and Huxley [20] established the famous nonlinear dynamic differential equation, namely the H-H equation. This equation can be used to describe the nonlinear phenomena that occur in the nerve membrane, such as self-excited oscillation, chaos, and multiple stability problems. Rosenblatt [21] proposed the Perceptron model, which is the first physically constructed artificial neural network with learning ability; Widrow [22] proposed the adaptive (Adaline) linear component model, a continuous self-adapt to the linear cell neural network model. In short, through the joint efforts of many scientists, artificial neural networks have entered the stage of commercial application.

The artificial neural network can achieve the approximation of any nonlinear mapping through learning, and it can be applied to the identification and modeling of nonlinear systems without being restricted by the nonlinear model [23]. Its fault tolerance is reflected in the fact that even if a part of the system is lost, the overall activity will not be affected [24]. Artificial neural network-based artificial intelligence has familiarity-based recognition, classification, error correction, and time series

---

retention capabilities. Therefore, it has been widely used in various complex scenarios. The main application areas include economic forecasting [25-27], signal processing [28-30], disease diagnosis [31-33], intelligent driving [34-36], process control and optimization [37-39], image processing [40-42], etc.

According to their different functions, artificial neural networks can be divided into feedforward and feedback networks [43]. The main purpose of the feedforward neural network is to learn and recognize. The main function of the feedback neural network is to recurse the network information in stages. After the initial information is input, the information state can be transferred layer by layer, so that the entire network state can reach a dynamic balance. At the same time, through the real-time feedback of the feedback network, the information can be transmitted to various areas, and the content of the information can be output in the form of data, and finally integrated output through the output terminal [44]. The convolutional neural network is another extremely powerful network. It was first proposed by Le Cun [45] as a classifier for image recognition. Its basic structure mainly includes an input, convolutional, pooling, fully connected, and output. Good Fellow [46] proposed a neural network-based generative model (GAN) in 2014, which inverted the structure of traditional neural networks: its input is a set of low-dimensional noise, and the output is a synthetic image that can be faked. On this basis, Gao et al. proposed an improved GAN model [47], which uses Wasserstein distance to replace the traditional KL distance (Kullback-Leibler divergence), and uses a game theory model for training, which improves the stability and convergence of GAN.

---

### 3. Application of Artificial Neural Network in the Chemical Industry

The artificial neural network has been successfully applied to many fields of the chemical process. This article will review its application research progress in chemical process control, fault diagnosis, process optimization and product quality control.

#### 3.1 Application of Neural Network in Chemical Process Control

The heat exchanger is important chemical equipment used to control the temperature of the material in the rectification system and the reaction system. Due to the nonlinear behavior and complexity of the heat exchanger control process, the traditional PID (Proportion Integration Differentiation) control method is being replaced by the predictive control based on the neural network model [48]. Vasičkaninová et al. [49] used a neural network predictive control (NNPC) structure to control the heat transfer process. A neural network model is used to predict the future behavior of a controlled process with distributed parameters. In order to test its control efficiency, the tube heat exchanger is selected as the controlled object. The control goal is to maintain the temperature of the heated outlet stream at the required value and minimize energy consumption. The results show that the NNPC of the heat exchanger consumes less heating medium than the classic PID control, which proves the effectiveness and superiority of NNPC. Longo et al. [50] proposed an artificial neural network (ANN) model to predict the boiling heat transfer coefficient of refrigerant in a brazed plate heat exchanger (BPHE). The model considers the influence of plate geometry, operating conditions and refrigerant characteristics, and

the average error (MAPE) of the predicted value is 4.8%. Compared with most of the most advanced analysis and calculation programs available in the public literature for internal boiling of BPHE, the ANN model shows better predictive ability.

Compared with traditional PID control, Model Predictive Control (MPC) has higher operational efficiency. Shin et al. [51] used an artificial neural network (ANN) model to replace the existing linearization model, and used Aspen HYSYS to simulate the de-propanizer. They consider all feasible operating scenarios to generate a large amount of dynamic simulation data and use it to train and test artificial neural networks. Fig. 1 shows the operational procedure of the neural network model predictive control (NNMPC) system. Figs. 2 and 3 show the time responses of the neural network model for two outputs (i.e. propane mole fraction in the overhead and Tray 4 temperature). The blue, yellow and magenta lines represent the original simulation data used for training, validation, and testing, respectively. The red line represents the results predicted from the neural network model.

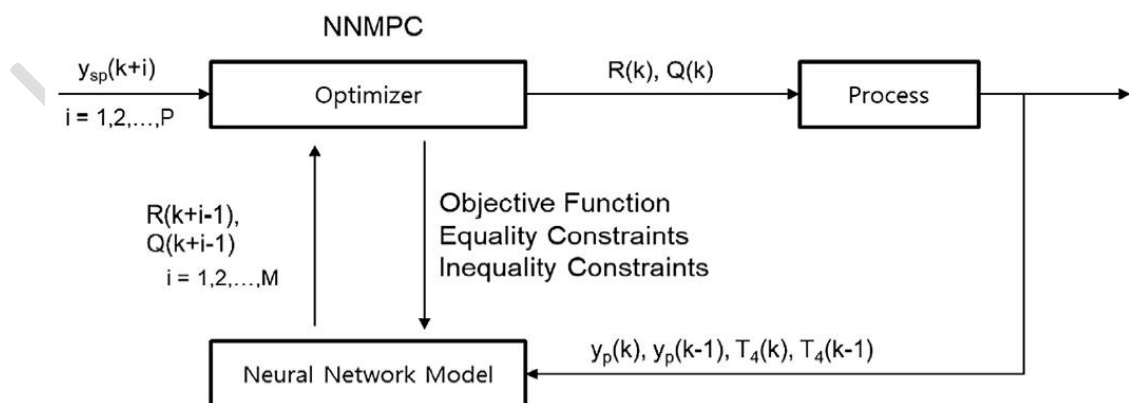

**Fig.1.** Data flow diagram of NNMPC system for depropanizer [51].

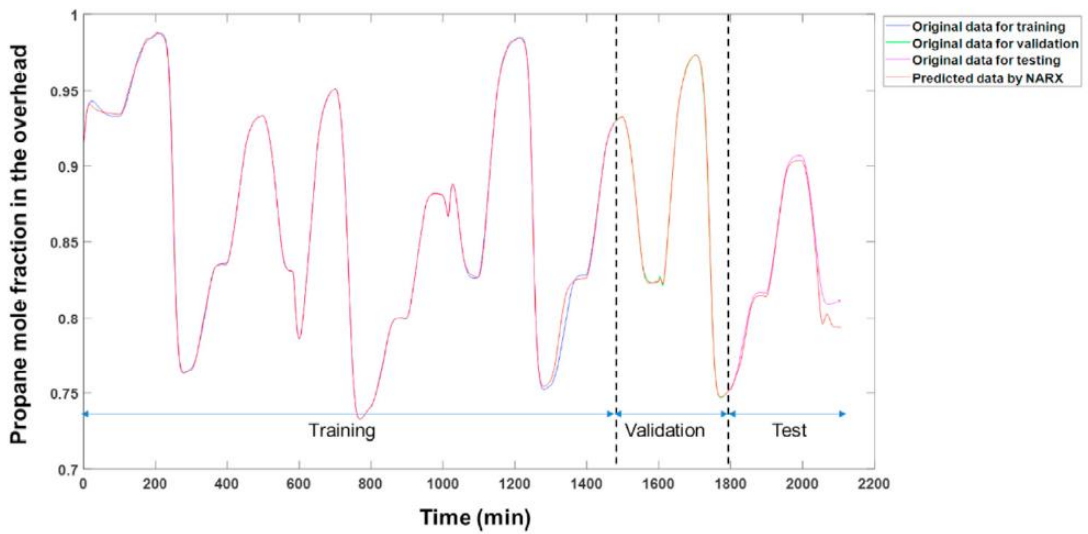

**Fig. 2.** Time response for propane mole fraction in the overhead [51].

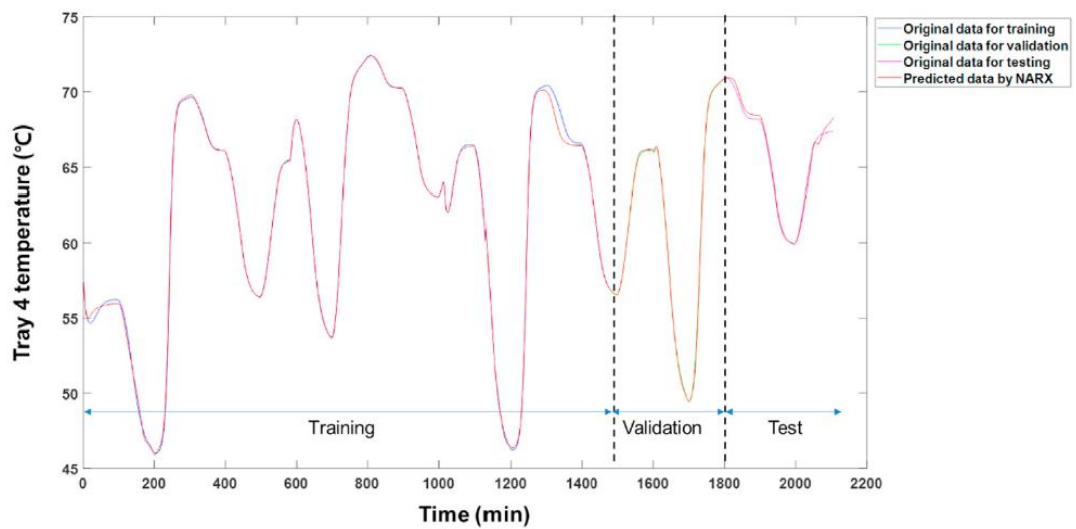

**Fig. 3.** Time response for Tray 4 temperature [51].

The results show that the developed model is integrated with the model predictive control (MPC) system, which replaces the existing mathematical model and provides stable, fast and accurate control system optimization results.

Osuolale et al. [52] proposed a strategy based on neural networks and the second law of thermodynamics to model and optimize the energy efficiency of distillation towers. The bootstrap aggregated neural network can enhance the accuracy and

---

reliability of the model. Aspen HYSYS is used for the distillation simulation of the methanol-water and benzene-toluene separation binary system, ultimately reducing utility consumption by 8.2% and 28.2%, respectively. Yang et al. [53] used a 3-layer BP network model to simulate and predict the process of ultrasonic-enhanced supercritical extraction of flavonoids from toona sinensis leaves. The effects of various factors such as extraction temperature, extraction pressure, fluid flow, amount of entrainer, extraction time and ultrasonic power on the extraction rate of total flavonoids are discussed separately, and the errors of the results obtained are small. Hu et al. [54] used artificial neural networks to simulate the start-up process of catalytic distillation towers. The learning algorithm of the artificial neural network used in this study is the Levenberg-Marquardt (LM) training algorithm. The input parameters are the composition and total moles of the initial feed liquid in the tower, and the output parameter is the time it takes for the catalytic distillation to start. The prediction performance of the artificial neural network increases with the increase of training data, and the prediction error gradually decreases.

### **3.2 Application of Neural Network in Fault Diagnosis**

Efficient fault prevention, fault detection and fault diagnosis of processes and devices are necessary conditions for safe, stable and efficient production. Artificial neural network models rely on powerful self-learning and nonlinear mapping capabilities, widely used in fault diagnosis and prevention of chemical processes and equipment. Currently, BP networks, radial basis (RBF) networks and adaptive networks are commonly used for fault diagnosis [2]. BP network is a kind of global

approximation neural network, and the ownership value and threshold value of the network need to be revised during the training process. Downs et al. [4] used BP neural network(BPNN) to simulate a more complex chemical process—the Tennessee Eastman (TE) benchmark process which is a widely used benchmark testbed for process monitoring in chemical engineering. The TE process flow is shown in Figure 4, which has 5 typical units (reactor, condenser, gas-liquid separator, desorption tower, circulating compressor). A total of 4 reactions are carried out, producing 2 products and 1 by-product. A 4-dimensional vector represents the 15 known fault numbers, and disturbances are added. Take out 500 sets of data to train the neural network, and then take 100 sets as test data. Through Levenberg-Marquardt's back-propagation algorithm for training, BPNN shows high fault recognition ability.

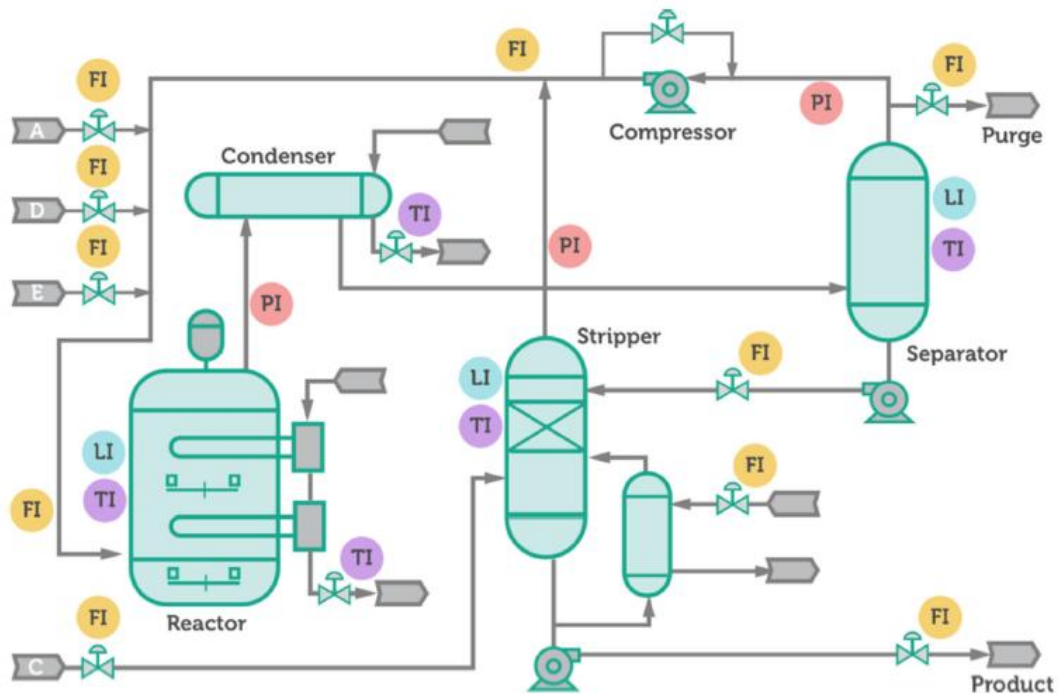

**Fig. 4.** Layout of TE process [4].

---

Gu [56] used BP neural network and RBF neural network to detect and diagnose faults, and found that the process relationship is static and linear in the numerical simulation examples. Manssouri et al. [57] established a reliable model ANN-ELM based on the ELM (Extreme Learning Machine) type artificial neural network, distinguishing between normal and abnormal patterns. It is applied to the distillation column with toluene/methylcyclohexane. All relevant inputs are: heating power, preheating power, reflux rate, feed rate, pressure drop and preheating temperature; the output is the tower top temperature. After training and testing in a database of 1000 samples, the results show that the prediction accuracy of the ELM model is very good. When the number of neurons in the hidden layer was 30, a low RMSE value (RMSE = 0.0168) was recorded during the test phase. The ANN-ELM predictive model is most suitable for the normal mode modeling of the variable operating point of the automatic continuous distillation column, and can be used for online detection and diagnosis.

### **3.3 Application of Neural Network in Process Optimization**

The production process of a chemical product often involves multiple influencing factors. The functional relationship between product yield and purity (output parameters) and these factors (input parameters) is complex and changeable, and cannot be correlated by mathematical models. Neural networks have a typical black-box nature. They can automatically extract "reasonable" solving rules by learning a set of examples containing correct answers, and establishing a mapping relationship between output and input. It has been applied to the process optimization

---

of chemical products. Kang et al. [58] optimized the polyvinylidene fluoride/polypropylene gradient composite as the filter media based on BP neural network. Taking the fiber membrane filtration resistance as the target value, MATLAB is used to construct a feed-forward neural network, and the algorithm can master the calculation ability through learning, training, and testing of sample data. Take voltage, receiving distance and injection speed as three input units, set up four hidden units, and filtering resistance as the output unit. Use the new function to create a network object for pre-feedback training. Set the network parameters, and feedback the result every 400 times of training. The Sigmoid excitation function is used to calculate the output value of each layer. In detail, 70% of the data is selected for training, 15% for correction, and 15% for testing to get the fitting curve. The optimized process parameters are the voltage of 30kV, the receiving distance of 16.8cm, and the flow rate of 1.6mL/h. The relative error of the BP neural network is 1.99%, and the resistance prediction value is 81.25 Pa, which has high prediction accuracy. Zhu et al. [59] used a new adaptive genetic neural network to optimize the process of extracting polysaccharides from burdock solid fermented *Ganoderma lucidum*. MATLAB R2016B was used to construct an adaptive genetic neural network, and the test data extracted from *Ganoderma lucidum* polysaccharide were used to train the neural network. Setting the initial interval of the ownership value threshold [-10,10] and the variable accuracy of  $10^{-4}$ , the adaptive genetic neural network algorithm was used to fit the experimental value of the polysaccharide content. The results show that the 13 sets of predicted values of the genetic neural network model

---

are almost completely fitted with the experimental ones, and the adaptive genetic neural network algorithm has higher prediction and optimization capabilities than the regression analysis method.

Su et al. [60] used a radial basis neural network model to optimize the injection molding process of the light guide. Taking the light guide strip of automobile front combination lamp as an example, the optimal Latin hypercube sampling method is selected to obtain the sample. Five parameters (melt temperature, mold temperature, holding time, holding pressure and cooling time) were selected as the input layer and two parameters (minimum volume shrinkage rate and minimum sink mark index) as the output layer, and a radial basis (RBF) neural network model was constructed. The Insight optimization module is used to obtain a set of parameters for the optimal injection molding process, and the actual simulation results are consistent with the predicted ones, which effectively improves the molding quality. Zhang et al. [61] used an artificial neural network (GA-ANN) to optimize the extraction process of Tibetan tea polysaccharide (TTP) and evaluated the in vitro antioxidant activity. Taking liquid-to-material ratio, extraction temperature, and extraction time as input parameters, and TTP extraction rate as output parameters, the response surface method (RSM) and genetic algorithm-artificial neural network (GA-ANN) were used to optimize the extraction process. Du et al. [62] applied an artificial neural network model and optimized genetic algorithm to optimize and predict the most suitable protoplast preparation process of *Paecilomyces tenuipes*. The protoplasts of *Paecilomyces tenuipes* were prepared according to the optimal preparation process

---

obtained by the above optimization. The average production of protoplasts in 5 parallel experiments was  $4.4 \times 10^7$  cells/mL, and the error with the predicted value of the ANN model was 0.23%.

#### 4. Conclusion

The artificial neural network has the ability of self-learning and fault tolerance. Training the artificial neural network based on limited experimental data can establish the mapping relationship between the output and the input. At present, artificial neural network technology has been successfully applied to various sub-fields of chemical process. This paper summarizes the research progress of its application in the fields of chemical process control, fault diagnosis and chemical process optimization, and shows that the artificial neural network technology is obviously superior to the traditional control technology and traditional optimization algorithm.

#### References

- [1] Song H, Sun X, Xiang S. Progress on the application of artificial neural network in chemical Industry. *Chem. Ind. Eng. Prog.*, **2016**, 35(12), 3755-3762.
- [2] Huang D, Song X. Application of Neural Networks to Chemical Fault Diagnosis. *Control Engineering of China*, **2006**, 13(1), 6-9.
- [3] Li C, Wang C. Application of artificial neural network in distillation system, A critical review of recent progress. *Asian J. Res. Comput. Sci.*, **2021**, 11(1), 8-16.
- [4] Downs JJ, Vogel EF. A plant-wide industrial process control problem. *Com. Chem. Eng.*, **1993**, 17(3), 245-255.

- 
- [5] Wang H, Mo R. Review of Neural Network Algorithm and Its Application in Reactive Distillation. *Asian J. Chem. Sci.*, **2021**, 20-29.
- [6] Zhao N, Lu J. Review of Neural Network Algorithm and its Application in Temperature Control of Distillation Tower, *J. Eng. Res. Reports*, **2021**, 20(4), 50-61.
- [7] Gao J, Chakraborty D, Tembine H and Olaleye O. Nonparallel Emotional Speech Conversion. INTERSPEECH 2019, Graz, Austria, September 2019.
- [8] Yang Y, Huang D. Research and Applications of Artificial Neural Networks, *Journal of East China University of Science and Technology*, **2002**, (05), 551-554.
- [9] McCulloch WS, Pitts W. A logical calculus of the ideas immanent in nervous activity, *Bulletin of Mathematical Biophysics*, **1943**, 5, 115-133.
- [10] Hebb DO, The Organization of Behavior, A Neuropsychological Theory[M]. Lawrence Erlbaum Associates, New Jersey, 1949.
- [11] Hopfield JJ; Feinstein DI; Palmer RG. 'Unlearning' has a stabilizing effect in collective memories, *Nature*, **1983**, 304(5922), 158-159.
- [12] Hopfield JJ. Neurons with graded response have collective computational properties like those of two-state neurons. *Proc. Natl. Acad. Sci.*, **1984**, 81(10), 3088-3092.
- [13] Hopfield JJ. Artificial neural networks , IEEE Circuits and Devices Magazine, **1988**, 4, (5), 3-10.
- [14] Kauffman GW, Jurs PC. Prediction of inhibition of the sodium ion-proton antiporter by benzoylguanidine derivatives from molecular structure, *Journal of Chemical Information and Modeling*, **2000**, 40(3), 753-761.
- [15] LeCun Y, Bengio Y, Hinton G. Deep Learning. *Nature*, **2015**, 521, 436-444.

- 
- [16]LeCun Y. Deep learning and convolutional neural networks, HOTCHIPS, **2015**.
- [17]Hinton G E, Salakhutdinov R. Reducing the dimensionality of data with neural networks. *Science*, **2006**, 313(5786), 504-507.
- [18]Hinton GE, Osindero S, Teh, YW. A fast learning algorithm for deep belief nets, *NEURAL COMPUTATION*, **2006**,18(7), 1527-1554.
- [19]Osindero, S; Welling, M and Hinton, GE. Topographic product models applied to natural scene statistics, *NEURAL COMPUTATION*, **2006**, 18 (2), 381-414.
- [20]Hodgkin A L, Huxley A F. A Quantitative Description of Ion Currents and Its Applications to Conduction and Excitation in Nerve Membranes, *Journal of Physiology*, **1952**, 117, 500-544.
- [21]Rosenblatt F. The perceptron, Probabilistic model for information storage and organization in the brain. *Psychological Review*, **1958**, 65(6), 386-408.
- [22]Widrow B, Hoff M E .Adaptive Switching Circuits [C] .1960 IRE WESCON convention record, part 4.Computers, Man-machine Systems, Los Angeles, 96-104.
- [23]Qi Y, Zheng Z. Neural Network Algorithm and Its Application in Supercritical Extraction Process, *Asian J. Chem. Sci.*, **2021** 9(1), 19-28.
- [24]Shi F, Gao J, Huang X. An affine invariant approach for dense wide baseline image matching. *International Journal of Distributed Sensor Networks (IJDSN)*, **2016**, 12(12).
- [25]Duan F, Fulin Y. A High Order Neural Network Model and Application in Economic Forecast, 2009 International Forum on Information Technology and Applications, **2009**, pp. 355-358.
- [26]Hansen JV, Nelson RD. Neural networks and traditional time series methods, A synergistic combination in state economic. *IEEE Transactions on Neural*

---

*Networks*, **1997**, 8(4), 863-873.

- [27]Zhu B, Lin J. Principal Component Analysis and Neural Network Ensemble Based Economic Forecasting, 2006 Chinese Control Conference, **2006**, pp. 1769-1772.
- [28]Mahalingam N, Kumar D. Neural networks for signal processing applications, ECG classification. *Australas Phys. Eng. Sci. Med.*, **1997**, 20(3), 147-151.
- [29]Gao J, Tembine H. Correlative Mean-Field Filter for Sequential and Spatial Data Processing, in the Proceedings of IEEE International Conference on Computer as a Tool (EUROCON), Ohrid, Macedonia, July 2017.
- [30]Kuwata R. Apparatus including a neural network used for signal processing, such as signal clustering, signal identification, and A/D conversion [P], US5420963A, 1995.
- [31]Abbass HA. An evolutionary artificial neural networks approach for breast cancer diagnosis. *Artificial Intelligence in Medicine*, **2002**, 25(3), 265.
- [32]Fujita H, Katafuchi T, Uehara T, et al. Application of artificial neural network to computer-aided diagnosis of coronary artery disease in myocardial SPECT bull's-eye images. *Journal of nuclear medicine official publication society of nuclear medicine*, **1992**, 33(2), 272-276.
- [33]Beheshti Z, Shamsuddin S, Beheshti E, et al. Enhancement of artificial neural network learning using centripetal accelerated particle swarm optimization for medical diseases diagnosis. *Soft Computing*, **2013**, 18(11), 2253-2270.
- [34]Gao J, Tembine H. Distributed mean-fieldtype filters for traffic networks, *IEEE Transactions on Intelligent Transportation Systems*. **2019**, 20(2), 507-521.
- [35]Jodas DS, Marranghello N, Pereira AS, et al. Comparing Support Vector Machines and Artificial Neural Networks in the Recognition of Steering Angle

- 
- for Driving of Mobile Robots Through Paths in Plantations. *Procedia Computer Science*, **2013**, 18(1), 240-249.
- [36] Kersti S, Ingalill MA, Ewa W. Driving after an injury or disease affecting the brain, an analysis of clinical data. *British Journal of Occupational Therapy*, **2018**, 81(7), 376-383.
- [37] Bloch G, Denoeux T. Neural networks for process control and optimization, Two industrial applications. *ISA Transactions*, **2003**, 42(1), 39-51.
- [38] Chen J, Huang T-C. Applying neural networks to on-line updated PID controllers for nonlinear process control, *Journal of Process Control*, **2004**, 14(2), 211-230.
- [39] Maciej ławryńczuk. Online set-point optimisation cooperating with predictive control of a yeast fermentation process, A neural network approach. *Engineering Applications of Artificial Intelligence*, **2011**, 24(6), 968-982.
- [40] Gao J, Shi F. A Rotation and Scale Invariant Approach for Dense Wide Baseline Matching. Intelligent Computing Theory - 10th International Conference, ICIC (1) **2014**, 345-356.
- [41] Wu XJ, Xu MD, Li CD, et al. Research on image reconstruction algorithms based on autoencoder neural network of Restricted Boltzmann Machine (RBM), *Flow Measurement and Instrumentation*, **2021**, 80, 102009.
- [42] Cao F, Yao K, Liang J. Deconvolutional neural network for image super-resolution, *Neural Networks*, **2020**, 132, 394-404.
- [43] Zhang LM. The model of artificial neural network and its application [M], Fudan University Press, 1993.
- [44] Wang H, Zhang Y, Li Y, et al. The orthogonal design and neural network optimization of the extractive distillation process. *Journal of Hebei University of Technology*, **2016**, 45(3), 48-56.

- 
- [45] LeCun Y, Bottou L, Bengio Y and Haffner P. Gradient-Based Learning Applied to Document Recognition. *Proceedings of the IEEE*, **1998**, 86(11), 2278-2324.
- [46] Goodfellow I, Pouget-Abadie J, Mirza, M, et al. Generative Adversarial Networks (PDF). Proceedings of the International Conference on Neural Information Processing Systems (NIPS 2014). pp. 2672–2680.
- [47] Gao J and Tembine H, Distributionally Robust Games, Wasserstein Metric, International Joint Conference on Neural Networks (IJCNN), Rio de Janeiro, Brazil, July 2018.
- [48] Varshney K, Panigrahi PK. Artificial neural network control of a heat exchanger in a closed flow air circuit, *Appl. Soft Comput.*, **2005**, 5 (4), 441-465.
- [49] Vasičkaninová A, Bakošová M, Mészáros A, Klemeš JJ. Neural network predictive control of a heat exchanger, *Applied Thermal Engineering*, **2011**, 31(13), 2094-2100.
- [50] Longo GA, Mancin S, Righetti G, et al. Application of an Artificial Neural Network (ANN) for predicting low-GWP refrigerant boiling heat transfer inside Braze Plate Heat Exchangers (BPHE), *International Journal of Heat and Mass Transfer*, **2020**, 160, 119824.
- [51] Shin Y, Smith R, Hwang S. Development of model predictive control system using an artificial neural network, A case study with a distillation column, *Journal of Cleaner Production*, **2020**, 277, 124124.
- [52] Osulale F N, Zhan J. Energy efficiency optimisation for distillation column using artificial neural network models, *Energy*, **2016**, 106, 562-578.
- [53] Yang R, Qiu TQ, Ding CM. The simulation on ultrasound-enhanced supercritical fluid extraction with the artificial neural network. *Computers and Applied Chemistry*, **2007**, 9, 1201-1204.

- 
- [54]Hu H, Wu H X, Xu S M, et al. Predictions Catalytic Distillation Column Start-up Processes Via Artificial Neural Network. *Journal of Molecular Catalysis(China)*, **2006**, 20(4), 360-362.
- [55]WATANABE K, HIROTA S, HOU L, et al. Diagnosis of multiple simultaneous fault via hierarchical artificial neural networks. *AIChE Journal*, **1994**, 40(5), 839-848.
- [56]Gu L. Fault diagnosis of chemical process based on artificial neural network [D]. Shenyang University of Science and Technology, 2008.
- [57]Mansouri I, Boudebouz B, Boudad B. Using artificial neural networks of the type extreme learning machine for the modelling and prediction of the temperature in the head the column. Case of a C<sub>6</sub>H<sub>11</sub>-CH<sub>3</sub> distillation column, *Materials Today: Proceedings*, **2021**, 45, Part 8, 7444-7449.
- [58]Kang L, Wang L, Gao X. Process optimization of polyvinylidene fluoride/polypropylene gradient composite filter media based on BP neural network, *Acta Materiae Compositae Sinica*, **2021**, 38, 9. DOI : 10.13801/j.cnki.fhclxb.20210913.005.
- [59]Zhu H, Dong Y. Optimization of Polysaccharide Extraction from Ganoderma lucidum of Solid-state Fermentation in Burdock by Genetic Neural Network, *Northern Horticulture*, **2020**, 22, 103-108.
- [60]Su T, Huang Y, Ni J, et al. Radial Basis Neural Network -Based Light Guide Strip Injection Molding Process Optimization, *Modern Plastics Processing and Applications*, **2021**, 33(1), 36-39.
- [61]Zhang Bin, Yao Y, Zhang H, et al. Study on Extraction Technology Optimization and Antioxidant Activity of Tibetan Tea Polysaccharide, *Chemical Reagents*, **2021**,43(6), 842-847.

---

[62]Du L, Wei D, Li X, et al. Optimization of protoplast preparation conditions of *Pachylomyces tenuipes* RCEF4339, *Food and Fermentation Industries*, **2018**, 44(7), 69-75.

UNDER PEER REVIEW