

**DESIGN AND CONSTRUCTION OF A SMART-HOME AUTOMATION SYSTEM
(SHAS) USING NODEMCU AND GOOGLE ASSISTANT**

ABSTRACT

This paper presents the design and construction of a smart-home automation system using nodeMCU and Google assistant. The device consist of Enhanced Universal Synchronous Asynchronous Receiver Transmitter (EUSART) module that contains all clock generators, shift registers and data buffers necessary to perform an input or output serial data transfer independently of the device program execution. The NodeMCU (ESP8266) Wi-fi Shield connected the microcontroller to the provided Wi-fi network. The Arduino and MPLAB Programming Interface with the help of PICKit3 were used to run the code on PIC16F877A. Home appliances were controlled via a web page created using IFTTT for the voice command and the Blynk app for controlling hardware remotely and also display sensor data. IFTTT is a simple to use internet service that easily enables IoT devices to GET and POST data. The device was constructed based on low cost and reliable home controlled monitoring system for accessing and controlling electronics appliances remotely using any Smart phone with access to Google assistance or Computer web application. The device was test under different electronics appliances with different voltage capacities and was found efficient. Therefore, this device when used is capable of improving the living standard at home, reduces human effort, save energy and time thus make homes have sufficient automation.

KEYWORDS: smart-home automation system, nodeMCU and Google assistant

1. INTRODUCTION

The rapid growth in technological advancement has set a new conceptual model and pattern on the standard of living in our modern societies. Homes now have access to electric power, televisions, radio, and telephones. Domestic chores which used to be laborious are now made

easy by specialized machines to carry out some specific tasks such as, washing and drying which is made easy with the assistance of washing machines which reduces the labor of washing and drying of clothes. Heating, Ventilation and Air Conditioning (HVAC) appliances provide further improved convenience and comfort (Khatu et al., 2015).

Seeing the various numbers of electronic devices being made available in a household, a remote centralized automated home control system has become an increasingly useful and desired feature. Also, due to the advancement of wireless technology, there are several connections that are introduced such as Global System for Mobile Communication (GSM), Wireless Fidelity (WIFI), and Bluetooth. Each of the connections has its unique specifications and applications. Among the four popular wireless connections that are often implemented in a Smart-Home project (Smitha and Rumana, 2015; Erol-Kantarci and Mouftah, 2011). The capabilities of Wireless Fidelity (WIFI) are more than enough to be implemented in the design. Also, most of the current laptops/notebooks or Smartphones come with in-built Wireless Fidelity (WIFI) adapter which allows electrical appliances to interconnect with one another through the help of electronic components/devices allowing better convenience, energy efficiency, and security. It will indirectly reduce the cost of this system (Malik and Bodwade, 2017).

Home automation has been a feature of science fiction for many years and began to be put into practice in the early 20th century. However, despite the great interest, problems have limited the venture of home automation into the homes of the rich or hobbyists, among them including complexity, high costs, and multiple incompatible standards: However, in this project, it is intended to construct a low cost simple web-based home automation system (Lamine and Abid, 2014)

2. METHODOLOGY

DESIGN: The design of this project is done based on figure 1

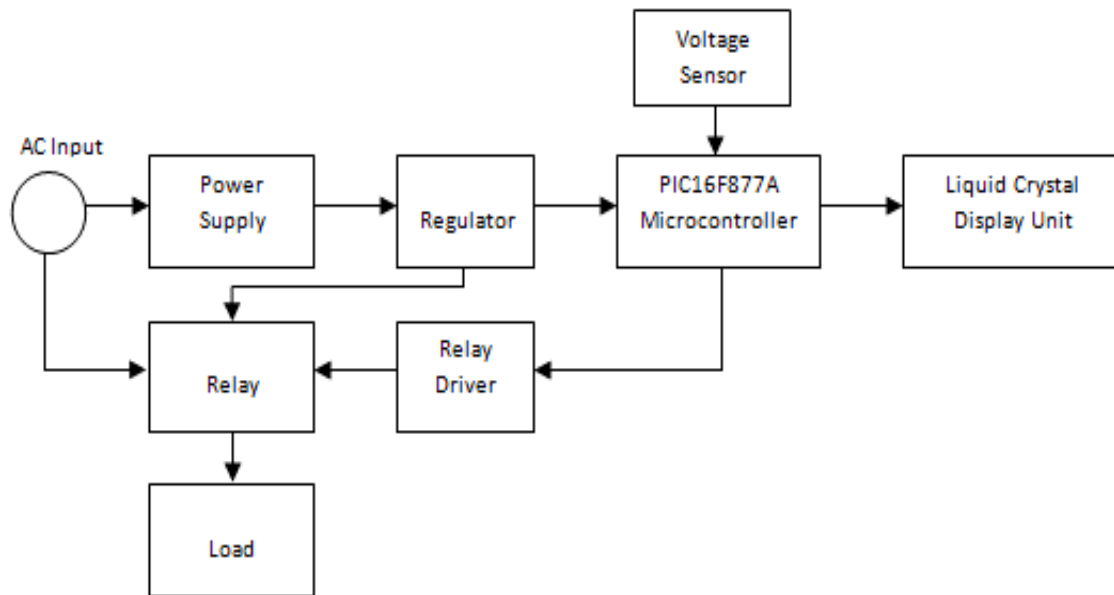

Figure 1: Block diagram of a web-based home automation system

POWER SUPPLY UNIT

This unit converts mains AC to regulated DC voltage for the internal components of the project.

This unit consist of

- i. **Rectifier Circuit:** A rectifier is an electrical device that converts alternating current (AC) to direct current (DC), a process known as rectification (Akande *et al.*, 2007). Diode is the major component of a rectifier. A diode is a two-terminal electronic component with an asymmetric transfer characteristic, with low (ideally zero) resistance to current flow in one direction, and high (ideally infinite) resistance in the other.

A diode's most common function is to allow current to flow in one direction (the diode's forward direction) while preventing current flow in the opposite direction (the reverse direction). As a result, the diode can be thought of as an electronic version of a check valve.

The output voltage of a center-tapped full wave rectifier is one-half of total secondary voltage expressed as (Akande *et al.*, 2007; Theraja and Theraja, 2005),

$$V_{out} = \frac{V_s}{2} - V_B \quad (1)$$

where V_B is the biased voltage of the diode. The peak inverse voltage (PIV) for a full wave center tapped rectifier is $2V_{P(out)}$ (Akande et al., 2007).

Ripple factor: the ripple factor was used to measure the amount of ripples present in the output DC voltage. Ripple factor is defined as the ratio of ripple voltage to the pure DC voltage expressed as (Theraja and Theraja, 2002)

$$\gamma = \sqrt{\left(\frac{V_{rms}}{V_{dc}}\right)^2 - 1} = 0.48 \quad (2)$$

A high ripple factor indicates a high pulsating DC signal.

$$\text{DC output current } I_{DC} = \frac{2I_{MAX}}{\pi} \quad (3)$$

where I_{max} is the maximum DC load current.

$$V_{dc} = \frac{2V_{max}}{\pi} \quad (4)$$

where V_{max} is the maximum secondary voltage.

Because of the full wave rectification, the period of the full wave signal was half the input period which was obtained as

$$T_{in}(\text{input period}) = \frac{1}{f} = \frac{1}{50\text{Hz}} = 20\text{ms}$$

$$T_{out} = \frac{20\text{ms}}{2} = 10\text{ms}$$

$$\text{The output frequency} = \frac{1}{T_{out}} = \frac{1}{10\text{ms}} = 100\text{Hz}$$

Therefore, the frequency of the full wave signal is double the input frequency.

ii. Filter Circuit:

In power supply, capacitors or inductors (choke) are used to smooth (filter) the pulsating DC output after rectification. The rectifiers' pulsating output has an average DC value and an AC portion known as ripple voltage. Filter capacitors bring the amount of ripple voltage down to a safe level. During the positive portion of the input, the capacitor in a filter circuit is charged to the peak of the rectified input voltage. The capacitor begins to discharge into the load when the input becomes negative. The rate of discharge is determined by the RC time constant formed by the capacitor and the load's resistance (Zhimwang et al., 2017).

The voltage across the capacitor was determined by (Malvino and Bates, 2006)

$$V_C = \frac{1}{1+RC} V_{in} \quad (5)$$

And the voltage across the resistor was determined by (Malvino and Bates, 2006)

$$V_R = \frac{RC}{1+RC} V_{in} \quad (6)$$

Transfer function from the input voltage to the voltage across the capacitor is expressed as (Malvino and Bates, 2006)

$$H_C = \frac{V_C}{V_{in}} = \frac{1}{1+RC} \quad (7)$$

Transfer function from the input to the voltage across the resistor is expressed as (Malvino and Bates, 2006)

$$H_R = \frac{RC}{1+RC} \quad (8)$$

Since a full wave rectifier was connected to a capacitor input filter, the peak-to-peak ripple was cut in half and when the full wave voltage was applied to the RC circuit, the capacitor discharges for only half as long (Malvino and Bates, 2006)

$$V_R = \frac{I_{dc}}{2fC} \quad (9)$$

Where f is the ripple frequency, I_{dc} is the dc current and C is the capacitor used.

For LPF,

$$C = \frac{1}{2\pi FR} \quad (10)$$

$$R = \frac{1}{2\pi FC} \quad (11)$$

EUSART MODULE:

The Enhanced Universal Synchronous Asynchronous Receiver Transmitter (EUSART) module is a serial I/O communication peripheral. It includes all of the clock generators, shift registers, and data buffers needed to accomplish an input or output serial data transfer independently of the device programme.

REGULATOR

Voltage levels are controlled by a voltage regulator. The voltage regulator is the preferred device when a constant, stable voltage is required. It produces a constant output voltage regardless of changes in the input voltage or load conditions (Neil, 2009). **NodeMCU (ESP8266) Wi-fi**

Shield:

This is the Wi-fi shield that connects the microcontroller to the available Wi-fi network. A microcontroller is a compact integrated circuit designed to govern a specific operation in the coding section. The main features of microcontrollers are RAM, flash memory, Timers/Counters, EEPROM, I/O Ports, USART, CCP (Capture/Compare/PWM module), SSP, Comparator, ADC (analog to digital converter), PSP (parallel slave port), LCD and ICSP (in-circuit serial programming) The 8-bit PIC microcontroller is classified into four types based on internal architecture such as Base Line PIC, Mid Range PIC, Enhanced Mid Range PIC and PIC18.

RELAY

A relay is a device with contacts that responds to an input signal (voltage or current) applied to a coil by opening and closing a switch. In today's technical systems, the electric relay is one of the most commonly utilised devices. Cars, washing machines, microwave ovens, and medical equipment, as well as tanks, aircraft, and ships, all include it (Mehta and Rohit, 2000).

POTENTIOMETER

A potentiometer, often described as a pot, is a three-terminal resistor with a sliding contact that acts as a voltage divider that can be adjusted. It operates as a variable resistor or rheostat when only two terminals, one end and the wiper, are employed. A potentiometer is a voltage divider used to measure electric potential (voltage); the component is an embodiment of the same idea, hence its name. Potentiometers are often used to operate electrical devices, such as audio equipment volume controls. Position transducers can be made from potentiometers that are controlled by a mechanism (Mehta, 2005). A resistive element, a sliding contact (wiper) that moves along the element, making good electrical contact with one part of it, electrical terminals at each end of the element, a mechanism that moves the wiper from one end to the other, and a housing that contains the element and wiper are all included in a potentiometer. Potentiometers are rarely used to control large quantities of power directly (more than a watt or so).

2.2 PROCEDURES FOR SETTING UP IFTTT FOR IOT HOME AUTOMATION

In this Study, Home appliances were controlled via a web page created using IFTTT as shown in figure 2 for the voice command and the Blynk app for controlling hardware remotely and also display sensor data. IFTTT is a simple to use internet service that easily enables IoT devices to GET and POST data. Additionally, it can be used to create GUI interfaces for viewing data, controlling devices, and triggers alerts/warnings.

Step 1: IFTTT account was created with a Google mail Account

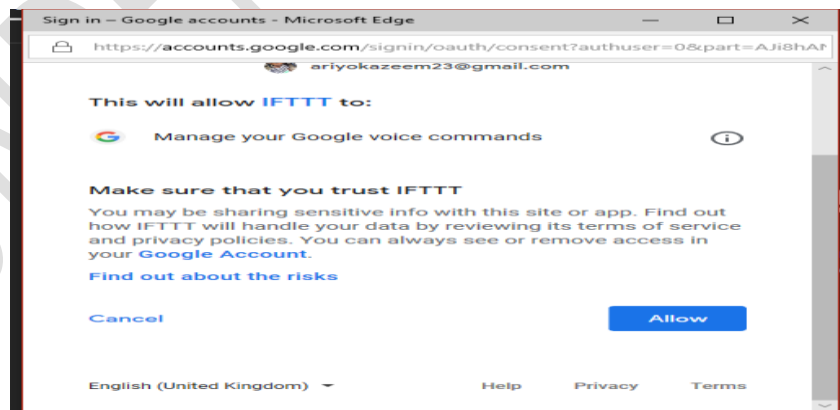

Figure 2: Google user profile

Step 2: Creating an IFTTT (If This, Then That) command was controlled via Google voice command and response was received from Google Assistance.

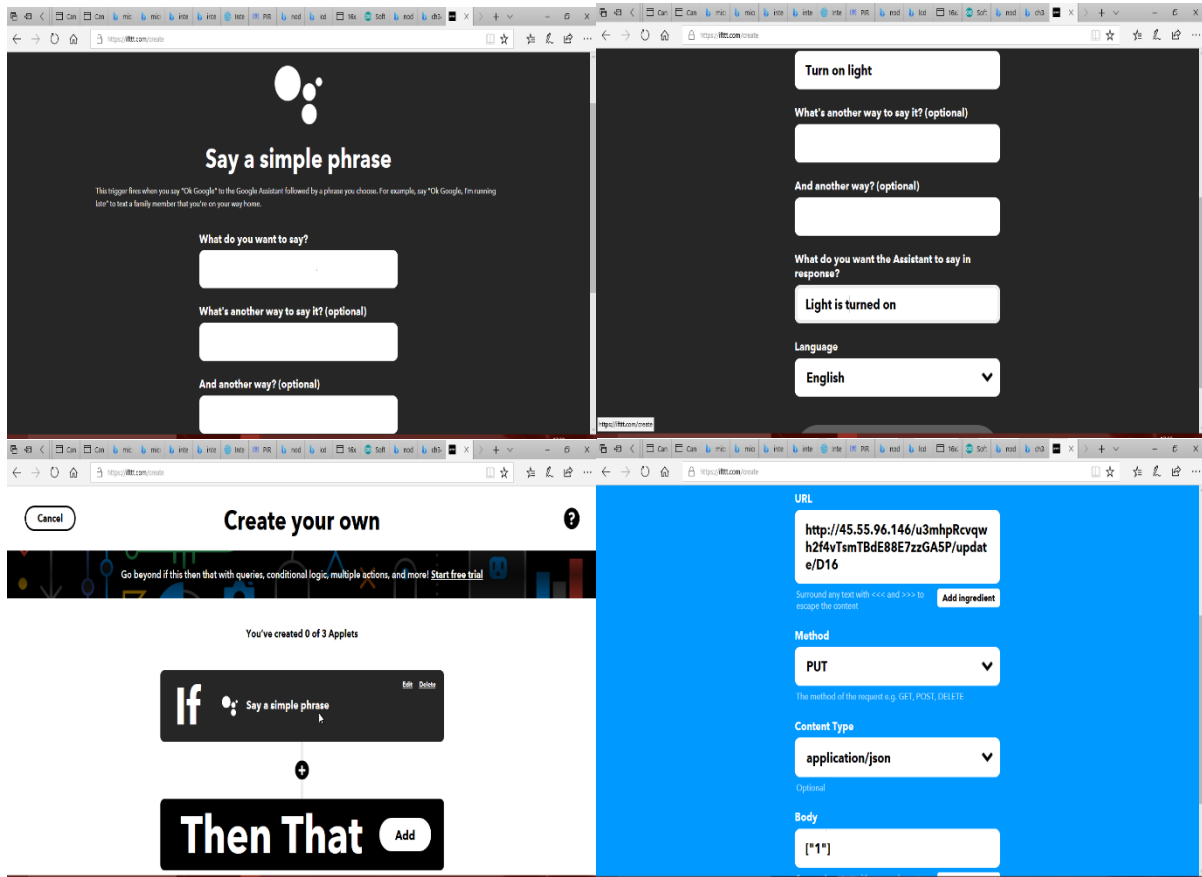

Figure 3: Users Command Dashboard

Step 3: We also created a Blynk Account using Google mail account

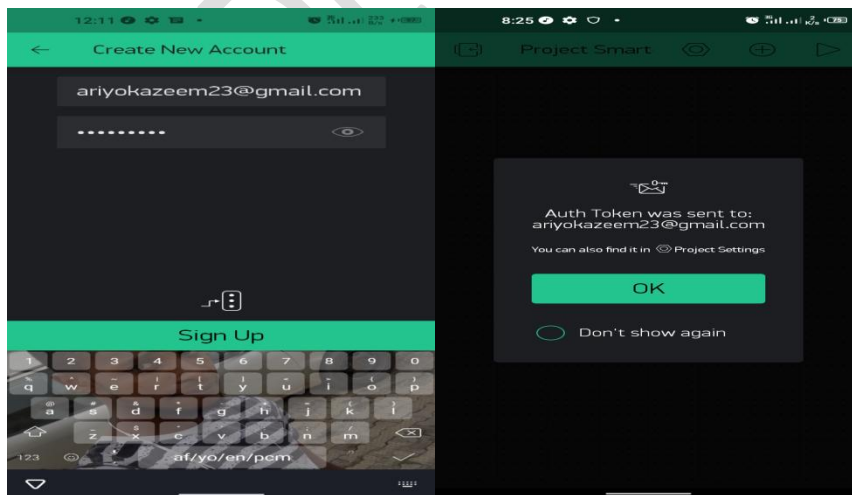

Figure 4: Blynk Account Interface

Step 4: Now, we created a new project on the Blynk App

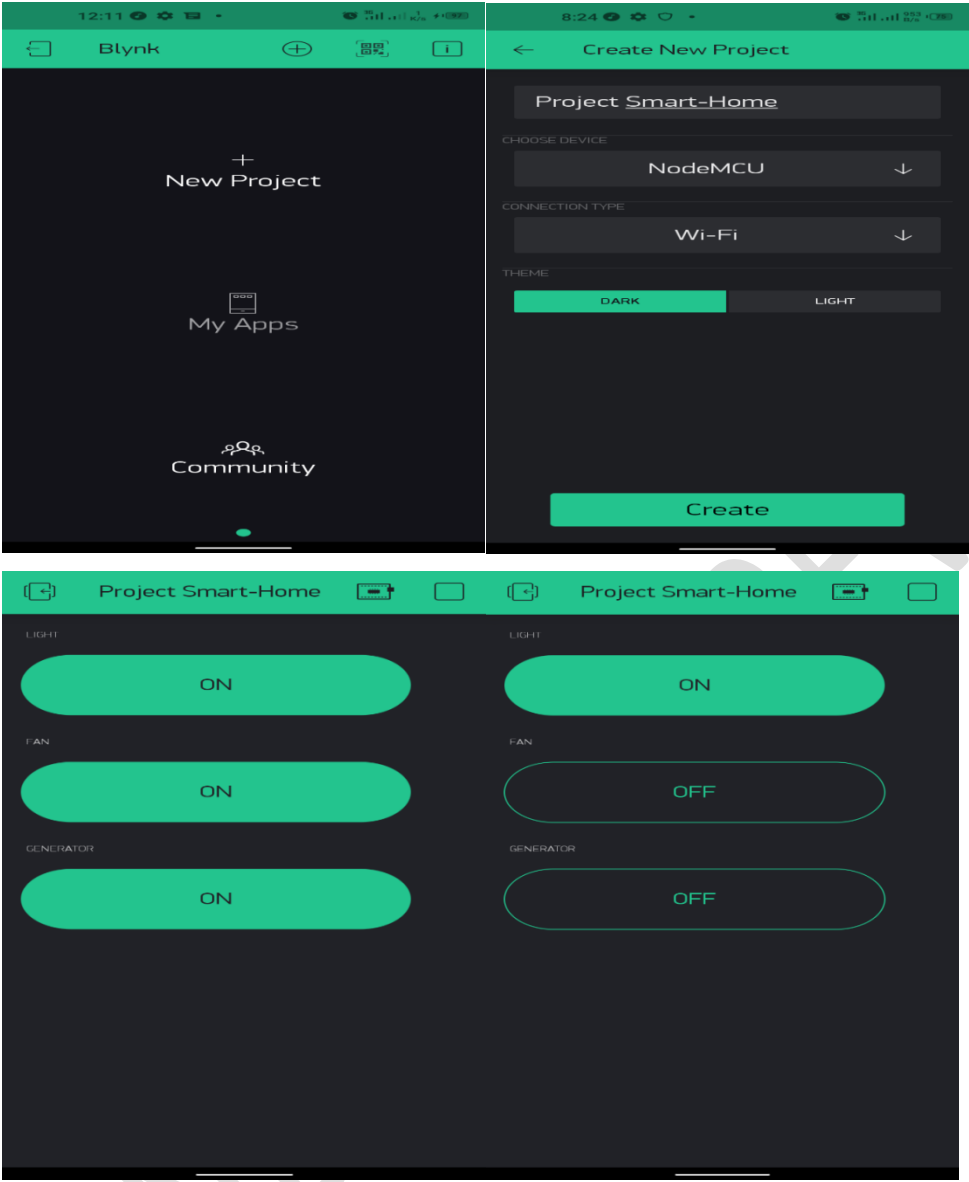
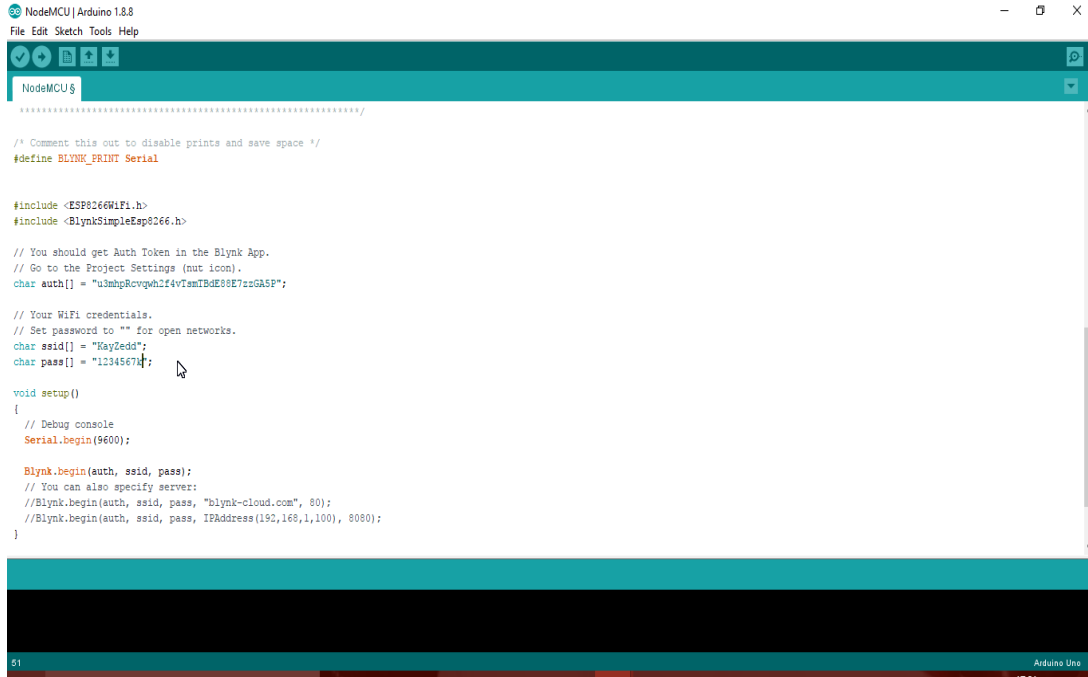

Figure 5: Final load interface with the created ON/OFF Button

Step 5: Running the control code on Arduino Interface, connecting Gmail Account with our NodeMCU Module



```
NodeMCU | Arduino 1.8.8
File Edit Sketch Tools Help

NodeMCU$

/* Comment this out to disable prints and save space */
#define BLYNK_PRINT Serial

#include <ESP8266WiFi.h>
#include <BlynkSimpleEsp8266.h>

// You should get Auth Token in the Blynk App.
// Go to the Project Settings (nut icon).
char auth[] = "u3mhpRcvpwh224vTmTBdE88E7z2zGA5P";

// Your WiFi credentials.
// Set password to "" for open networks.
char ssid[] = "KayZedd";
char pass[] = "12345678";

void setup()
{
  // Debug console
  Serial.begin(9600);

  Blynk.begin(auth, ssid, pass);
  // You can also specify server:
  //Blynk.begin(auth, ssid, pass, "blynk-cloud.com", 80);
  //Blynk.begin(auth, ssid, pass, IPAddress(192,168,1,100), 8080);
}
```

Figure 6: Arduino Programming Interface

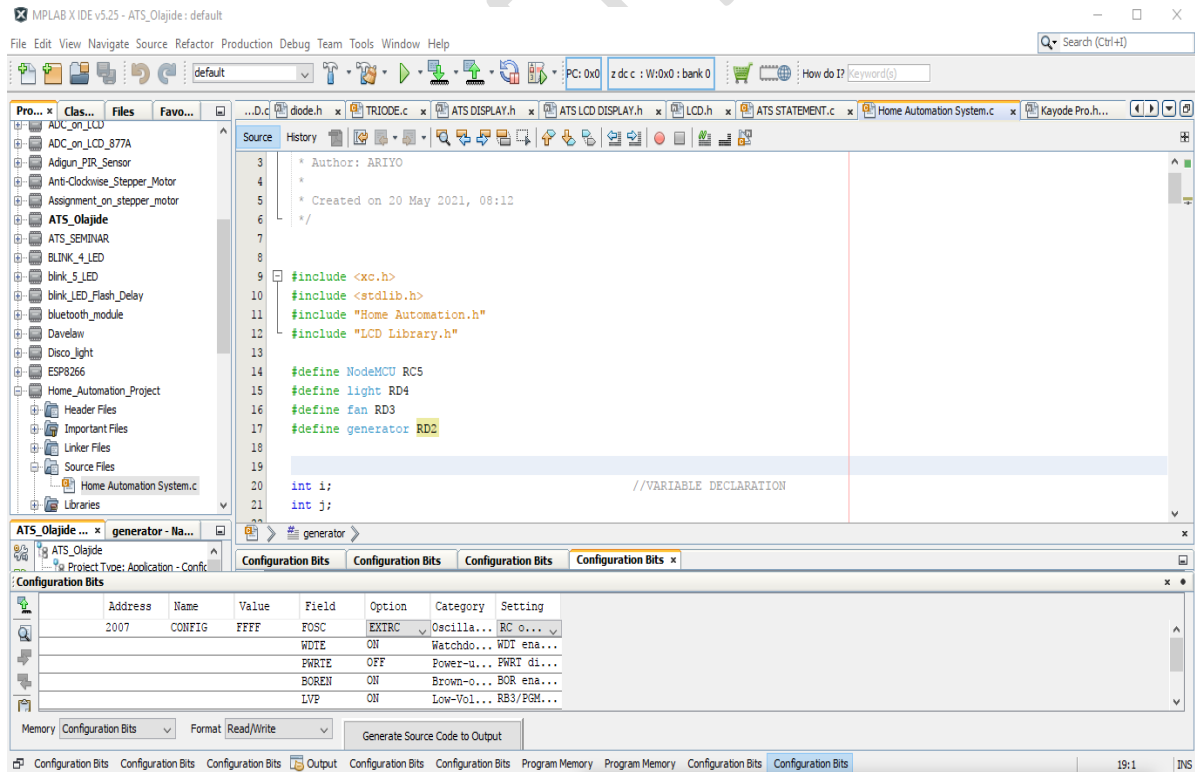

Figure 7: MPLAB Programming Interface

2.3 IMPLEMENTATION OF SMART-HOME AUTOMATION SYSTEM (SHAS)

The Blynk Application was used to control home appliances from a webpage using NodeMCU ESP8266 and PIC microcontroller. We connected three appliances such as electric bulb, fan and generator and they were controlled remotely using phone.

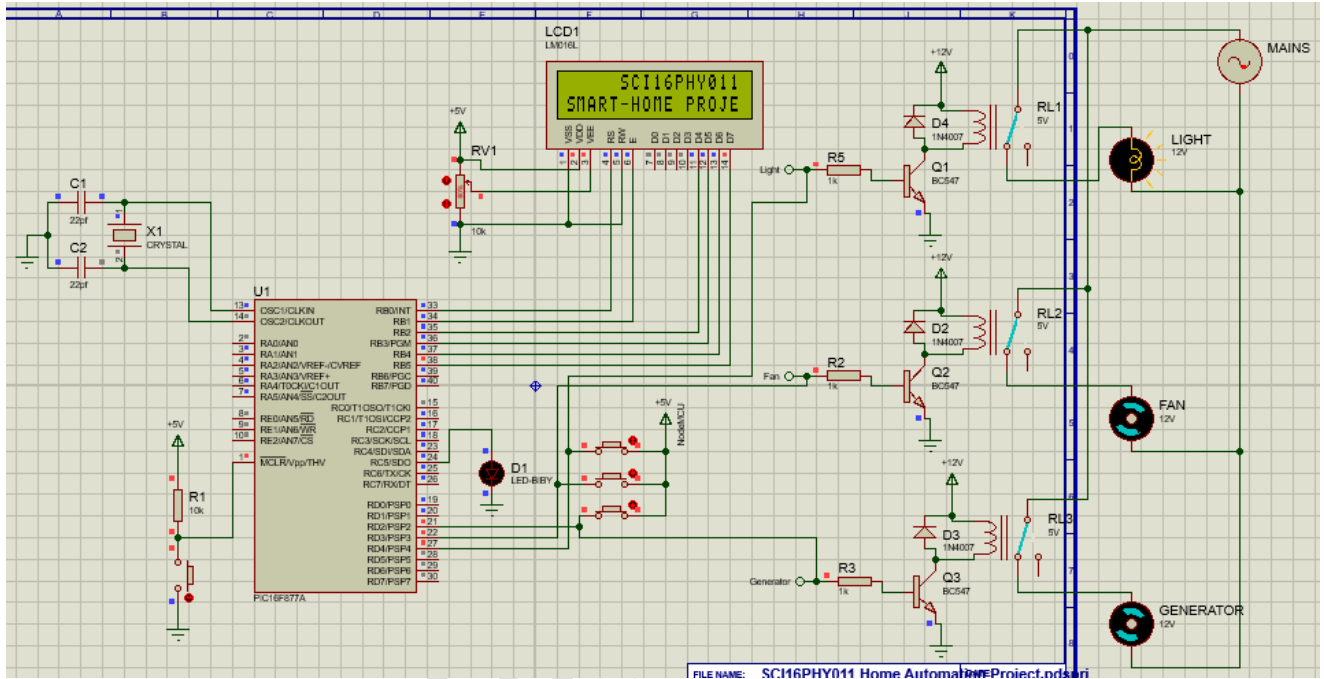

Figure 8: Complete circuit of the smart-home automation system



Figure 9: Inside view of the smart-home automation system



Figure 10: Complete Framework of the smart-home automation system

The circuit consists of microcontroller-the Pic16f877A and The NodeMCU ESP8266. Microcontroller integrate all the essential components of the circuit making it the heart of the circuit, and were dedicated to perform one task and execute one specific application. They contain memory, programmable input/output peripherals they were responsible for storing the data and control the operation of the entire system. Each microcontroller has only one EUSART input. Using ESP8266 module requires a EUSART input from the microcontroller, this prompts the use of one separate microcontroller along with the NodeMCU module. The Android device connected to this module sends commands offline through the Blynk app and online through Google commands and then displays on the LCD screen. The digital logic input pin P0.5 was toggled from logic 1 or High to logic 0 or Low using the switch SW1. The R1 resistor acted as a pull-up resistor. It was connected with the logic voltage from the supply source of 5V. So, when the switch was not being pressed, the logical input pin was always a default voltage of 5V or the pin is always high until the switch is pressed and the pin is shorted to the ground making its logic Low. Transistor Q1, Q2, Q3, works as a switch and are responsible for powering up the relay by supplying a 12V to one terminal of the relay when it is closed. RL1, RL2, and RL3 relays are electromagnetic switches responsible for controlling the desired load connected to the system once it is energized by Q1, Q2, and Q3.

3. RESULTS

Table 1: Measurement at various terminals of the smart-home automation system

Circuit Test	Test Data	Expected Value	Measured value
Dc input voltage	Voltage	12.0V	12.0V
Regulated DC voltage	Voltage	5.0V	4.7V
Transistor 1 base voltage	Voltage	0.7V	0.7V
Transistor 2 base voltage	Voltage	0.7V	0.65V
Transistor 2 base voltage	Voltage	0.7V	0.62V
Max. PIC power Rating	Current	700mA	698mA
Maximum power Rating	Current	10Amps	10Amps

4. DISCUSSION

Table 1 presents the measurement at various terminals of the smart-home automation system. The result shows that the expected value and measured value of DC input voltage is the same either 12V. Differences of 0.3V was recorded between the expected and measured values of regulated DC voltage. Maximum PIC power rating for expected value is 700mA and 698Ma for measured value.

5. CONCLUSION

The home automation utilizing the Internet has been designed, constructed and demonstrated to work attractively by interfacing basic appliances to it and the apparatuses were effectively controlled remotely through the web. The outlined framework screens the sensor information, as well as impels a procedure as indicated by the necessity. The device has been effectively outlined and tried.

REFERENCES

- Akande, S.F.A., Kwaha, B.J and Alao, S.O. (2007). *Fundamentals in Electronics*. Jos University Press Ltd, Jos, Nigeria
- Erol-Kantarci, M., & Mouftah, H. T. (2011) “Wireless Sensor Networks for Cost-Efficient Residential Energy Management in the Smart Grid. *IEEE Transactions on Smart Grid*. 2(2). pp 314-325.
- Khatu M, N. Kaimal, P. Jadhav, and S. A. Rizvi (2015). Implementation of Internet of Things for Home Automation,” *Int. J. Emerg. Eng. Res. Technol.*, vol. 3, no. 2, pp. 7–11,
- Lamine H and H. Abid (2014). Remote control of a domestic equipment from an Android application based on Raspberry pi card. *STA 2014 - 15th Int. Conf. Sci. Tech. Autom. Control Comput. Eng.*, pp. 903–908, 2014, doi: 10.1109/STA.2014.7086757.
- Malik N, and Bodwade Y (2017). Literature Review on Home Automation System,” *Ijarcce* 6(3) pp. 733–737, 2017, doi: 10.17148/ijarcce.2017.63173.
- Malvino A. and Bates J. D. (2006): *Electronics Principles*. 7th edition, McGraw-Hill Science. Pg. 946-1223
- Mehta V.K. (2005): *Principle of Power Systems*. 5th edition, S.Chand and company LTD. Pg. 41-111.
- Mehta V.K. and Rohit M. (2000): *Principles of electronics*. 11th edition, S.Chand and company LTD. Pg. 442-467.
- Neil storeg (2009). *Electronics A systems approach*. 4th Edition. Pearson Education Limited. Pages, 821.
- Smitha T.A and M Rumana (2015). Hand Gesture Based Home Automation for Visually Challenged. *Int. J. Innov. Eng. Rresearch Technol*. 2(4) pp. 1–7.
- Theraja A.K and Theraja B.L (2005). *Electrical Technology*. Multicolor Edition. S Chand And Company Ltd, Ram Magar, New Delhi. pp 1116 -1123
- Theraja B.L. and Theraja A.K. (2002): *A textbook of Electrical Technology*. 24th edition, S.Chand and company LTD. Pg. 442-467.
- Zhimwang J. T., Yunisa Yahaya, Ibrahim Aminu, Esther M. Fomson, and Dachomo D.B. (2017). Design and construction of a dual regulated $\pm 0-35$ volts dc power supply using LM317 and LM337 voltage regulator. *African Journal of Natural Sciences*. 20.107-118.