

3-BLADE CASSAVA STEM CUTTING MACHINE

Abstract

A three blades cassava stem cutter was designed and fabricated in the Federal University of Technology, Owerri with the aim of reducing time expended and drudgery involved in cutting cassava stem for asexual propagation of the root plant. The developed machine has a dimension of 100cm×73.5cm×70cm with three cutting circular blades rotating in an anti-clockwise motion against the cassava stem bundle pushed towards it by a human operator. The machine was evaluated at varying speeds of 515rpm, 578rpm, 610rpm and 652 rpm with cassava bundles holding 5, 10, 15, and 20 stems in a bundle. The machine's cutting efficiency was rated 100% as the stem cutter efficiently cut a cassava bundle of 20 stems in 15seconds at 515rpm and cuts a bundle of 20 stem at 652rpm within 13seconds. The stem cutter was further analyzed for maximum capacity per hour and the result obtained was 19,000stems per hour.

Keywords: Cassava, Cuttings, Blades, efficiency, stem and bundle

1.0 Introduction

Cutting is a separation technique where a solid body is mechanically divided along a predetermined part using a cutting tool [1]. Cutting is one of the methods used in asexual propagation of root plants [2]. Cassava roots are the second most important staple crop after

maize and are propagated by stem cuttings [3]. As a perennial crop, they can grow up to 24m in height and a benchmark for food security for the poor [4] [5]. Cassava stem handling and propagation involve several steps. Long cassava stems should be obtained from 10-12months old, then keep up to 2-3 days (not more than 2 weeks) to enable fast sprouting. When ready to plant, the stem should be cut to 25 cm length with at least 5-7 nodes on it using sharp tools like a cutlass, secateurs etc. and should be done avoiding bruises. These operations are usually done manually. Considering spacing requirements of 1m by 0.8m on the crest of mounds or ridges; cuttings should be planted horizontally with stem completely buried 5cm deep in dry regions and vertically (slanted or angled) with one-third of stem above the soil in wet regions [6].

Nigeria is currently the largest producer of cassava in the world with an estimated capacity of 57 million metric tonnes per year (FAO, 2017) and losses around ₦1 trillion because of poor value addition. Thailand on the other hand is the largest exporter of dried cassava, responsible for about 80 per cent of global trade in the crop and its by-products [7]. Transforming cassava into various by-products in Nigeria has the potentials of improving its food security situation, diversify its manufacturing base, trade balance and improve livelihoods through job creation [8]. In most of the country, cassava cultivation is done manually especially stem cutting operation. To maximize the opportunities present in cassava production, Nigeria should improve or maintain its current world producer status of the crop. This necessitated research on the development of a small-scale cassava stem cutter in the Federal University of Technology, Owerri that will supplement other efforts made to reduce drudgery, improve handling, affordable and increase cassava production by shortening the time spent during planting.

Materials and Methods:

A cassava stem cutting machine was designed and fabricated. The Isometric view is shown in Figure 1 and a orthographic view is shown in Figure 2.

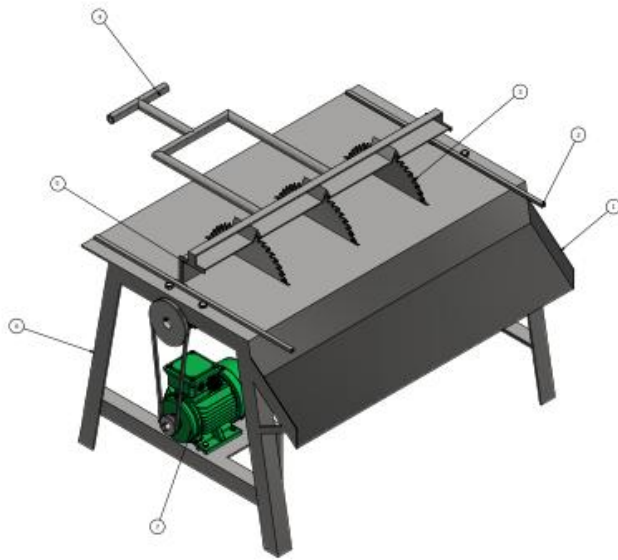

TABLE	
ITEM	DESCRIPTION
1	DISCHARGE CHUTE
2	SLIDER
3	CUTTING BLADE
4	PUSHER HANDLE
5	PUSHER
6	FRAME
7	ELECTRIC MOTOR

Figure 1. Isometric of a 3-blade cassava stem cutting machine

UNDER PTV

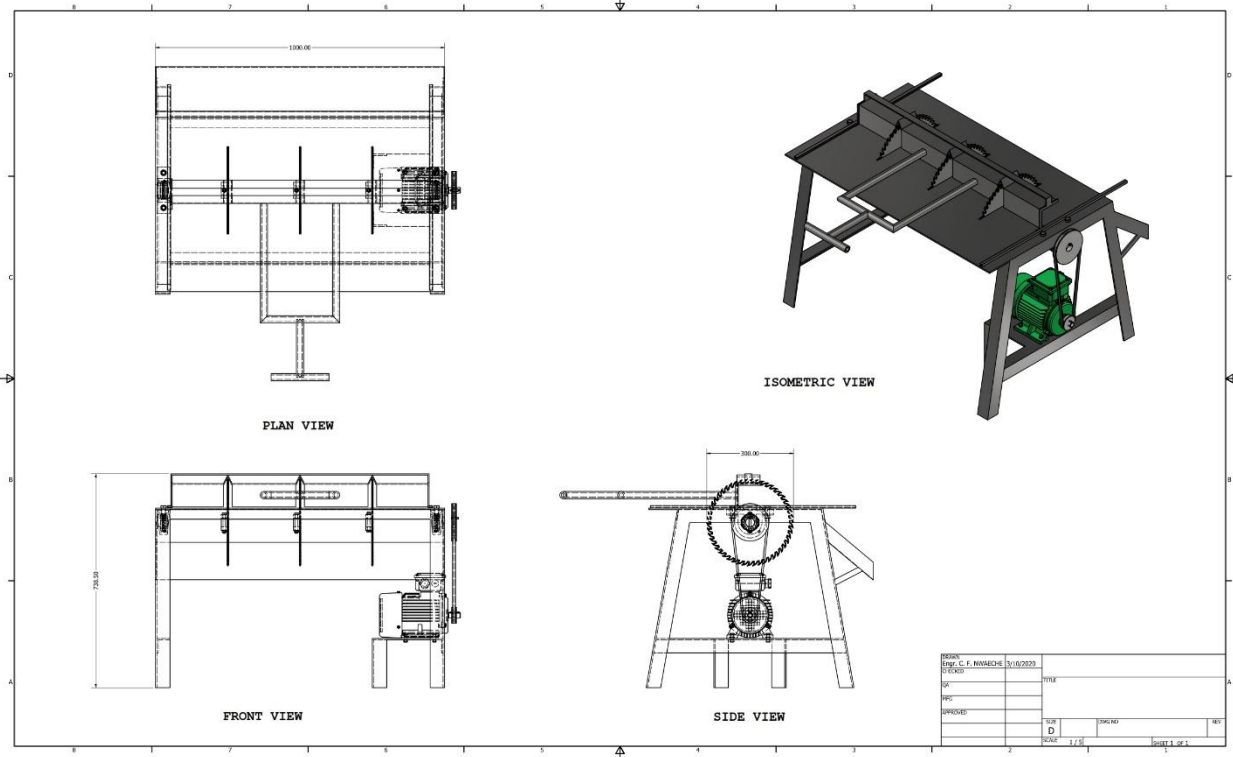

Figure 2. Orthographic view of the 3-blade cassava cutting machine

Operation of Machine

The operator positioned a stem bundle on top of the machine, parallel to the horizontal pusher (5). Then he pushed the pusher to convey the stems of approximately 100cm of length towards the rotating cutting blades (3) powered by a 2 hp electric motor(7), which cut and metered the stems into approximate lengths and the cuttings were collected from the discharge chute. The horizontal pusher had a pair of sliders that were lubricated to ease movement. The operator at intervals controls the pusher to reduce stem bending during a cutting operation.

2.1 Design and calculation

The electric motor rating employed is a 2 hp (? kW) with a speed of 1420rpm.

Pulley Selection

$$\frac{N_1}{N_2} = \frac{d_1}{d_2}$$

Where N_1 = Speed of electric motor pulley

N_2 = Speed of shaft pulley

d_1 = Diameter of electric motor pulley used in the design

d_2 = Diameter of shaft pulley used in the design

Length of Belt

$$L = \pi(r_2 + r_1) + 2x + \frac{(r_2 - r_1)^2}{x}$$

Where r_1 = Electric motor pulley radius

r_2 = Shaft pulley radius

x = Centre distance between electric motor and shaft pulley

∴ A type v-belt was selected

Determination of Belt Angle of Contact and Power Transmitted

$$\sin\alpha = \frac{r_2 - r_1}{x}$$

$$\theta_1 = 180^\circ - 2\alpha$$

$$\theta_2 = 180^\circ + 2\alpha$$

Where θ_1 = Angle of contact on the electric motor pulley

θ_2 = Angle of contact on the shaft pulley

∴ Designing for pulley which $\mu \cdot \theta$ is small

Where μ = Coefficient of friction between belt and pulley rim

Then, Belt velocity (v),

$$v = \frac{\pi d_1 N_1}{60}$$

Mass of the belt per meter length = Area × Length × Density

Centrifugal tension (T_c),

$$T_c = m \cdot v^2$$

Maximum tension in the belt (T_m),

$$T_m = \text{Allowable tension on belt} \times \text{Area}$$

Total tension in the belt

If, T_1 = Tension in the taut side of the belt

T_2 = Tension in the slack side of the belt

$$T_m = T_1 + T_c \dots \dots \dots (1)$$

Making T_1 subject formulation in equation (1)

$$T_1 = T_m + T_c$$

$$2.3 \log\left(\frac{T_1}{T_2}\right) = \mu \cdot \theta_2$$

∴ Power transmitted per belt

$$P = (T_1 - T_2)v$$

Driven Shaft Diameter Determination

Torque transmitted by driven pulley shaft (T),

$$T = \frac{\text{Electric motor power} \times 60}{2\pi \times \text{Speed of shaft pulley}}$$

Bending moment on the driven shaft (M),

$$M = (T_1 + T_2 + 2T_c)K \times I$$

Where K = Distance from the centre of the driven pulley to the nearest bearing

I = Number of the belt used

Twisting Moment (T_e),

$$T_e = \sqrt{T^2 + M^2}$$

$$\therefore T_e = \frac{\pi}{16} \times \tau \times D^3$$

Where τ = Permissible shear stress on the driven shaft

D = Driven Shaft diameter

Force applied and circular blade cutting force

Actual Force applied by the operator during operation and the cutting force is difficult to determine due to difference in human mass and displacement on the cutting blade geometry during rotation. To identify this displacement on the cutting blades geometry forces applied to each circular blade individual tooth must be put into consideration to determine the total cutting force required [8].

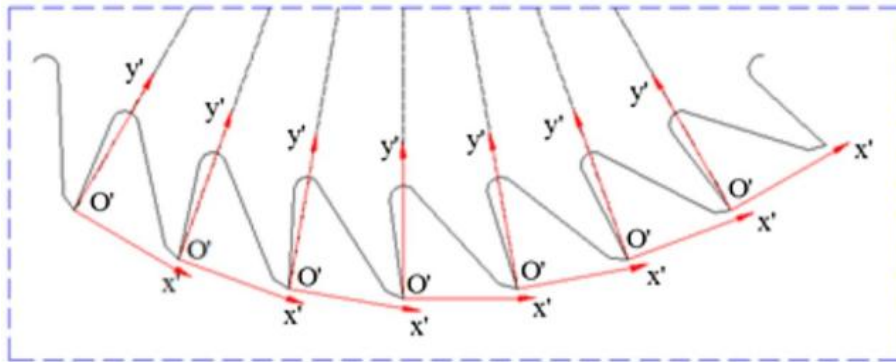

Figure 3. Schematic showing forces acting on individual circular blade tooth. Source: Yazdan Kordestany and Yongsheng Ma

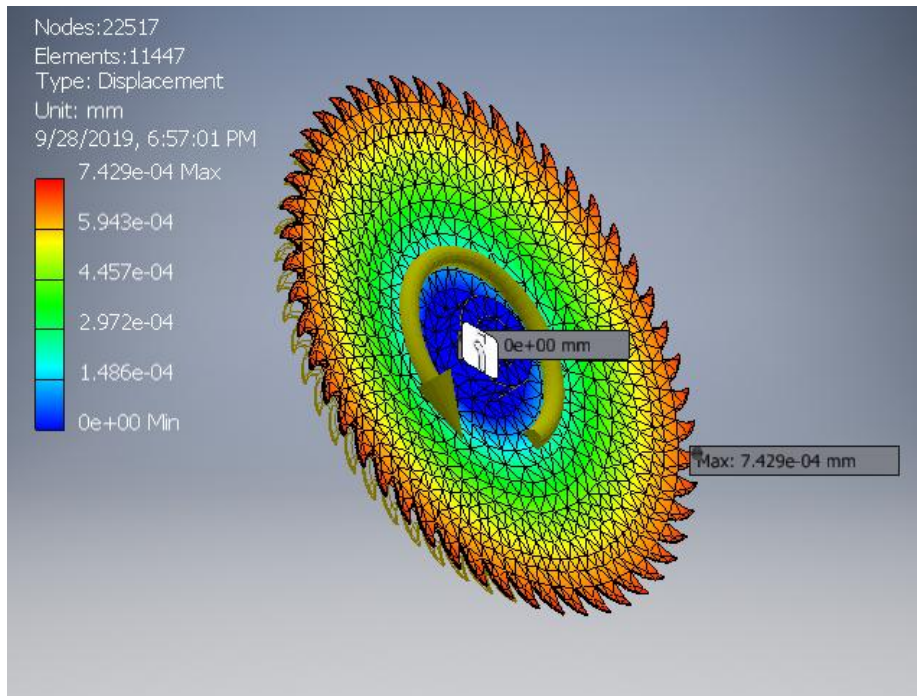

Figure 4. Finite Element Analysis showing displacement across each circular blade

Figure (4) above shows the displacement across the rotating blade as it rotates at the highest rotating speed of 1420rpm. These displacements are represented by different colours. Red colour represents the highest displacement while blue colour represents the lowest displacement.

Predicting Force Applied and work done by Operator

The average human adult weight in Nigeria is 60.745kg [10].

$$F_F = \mu_K F_N$$

Where F_F = Frictional force

μ_K = Coefficient of friction between pusher slider and machine top surface (Metal to Metal

Contact lubricated = 0.03)

F_N = Normal force

$F_N = \text{Mass} \times \text{Acceleration due to gravity}$

$$\therefore F_F = 0.03 \times 60.745 \text{kg} \times 9.8 \text{m/s}^2$$

$$= 17.859 \text{N}$$

$\text{Work} - \text{done} (W) = F_S \cos \theta$

Where S = displacement between the pusher and when cassava stakes meet circular blade = 0.15m Approx.

$\theta = \text{Angle between } F \text{ and } s = 0$

$$\therefore \cos \theta = 1$$

$$= 17.859 \times 0.15 \times 1 = 2.678 \text{ Joules}$$

3.0 Results and discussion

To assess the machine, cutting shaft speeds of 515, 578, 610 and 652 rpm were selected and different stem bundles of 5, 10, 15 and 20 were fed at different time intervals which were done using a stopwatch. The formulas below were used to determine the machine's efficiency and capacity;

$$\text{Cutting efficiency} = \frac{\text{Actual number of cuttings gotten}}{\text{Expected number cuttings from each bundle}} \times 100\%$$

$$\text{Machine output capacity} = \frac{\text{Quantity of cassava cuttings produced}}{\text{time for cutting to be completed (s)}}$$

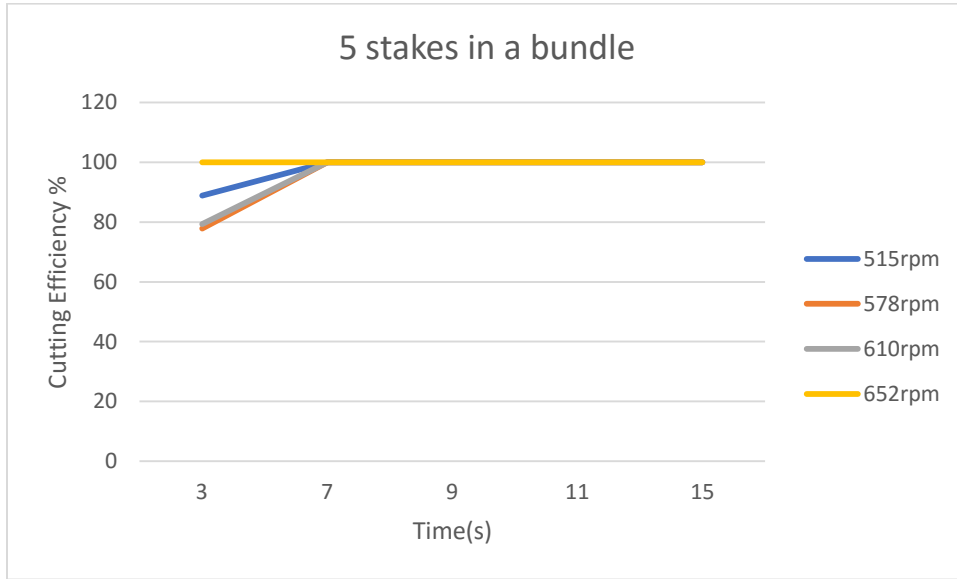

Figure 5. Effect of time on efficiency for various cutting speeds

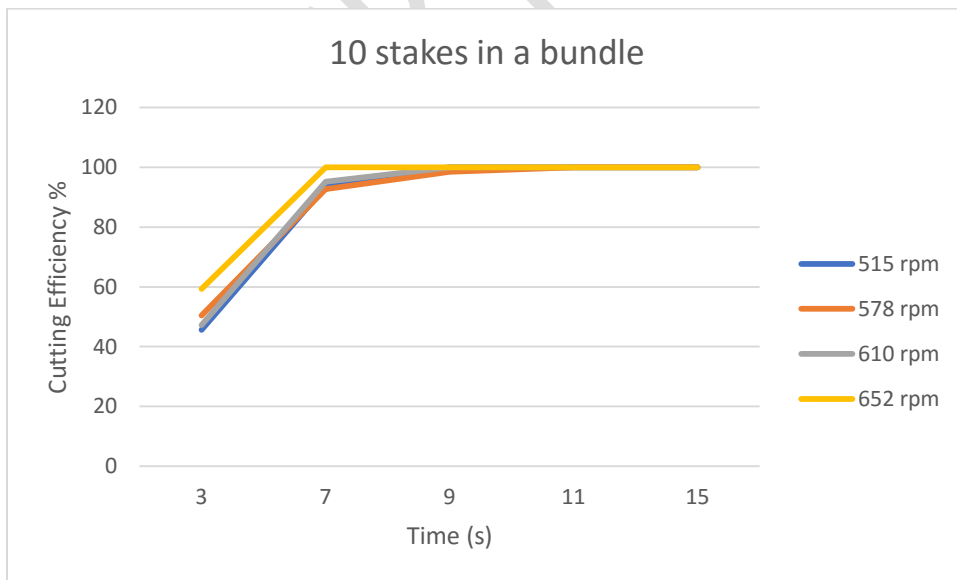

Figure 6. Effect of time on efficiency for various cutting speeds

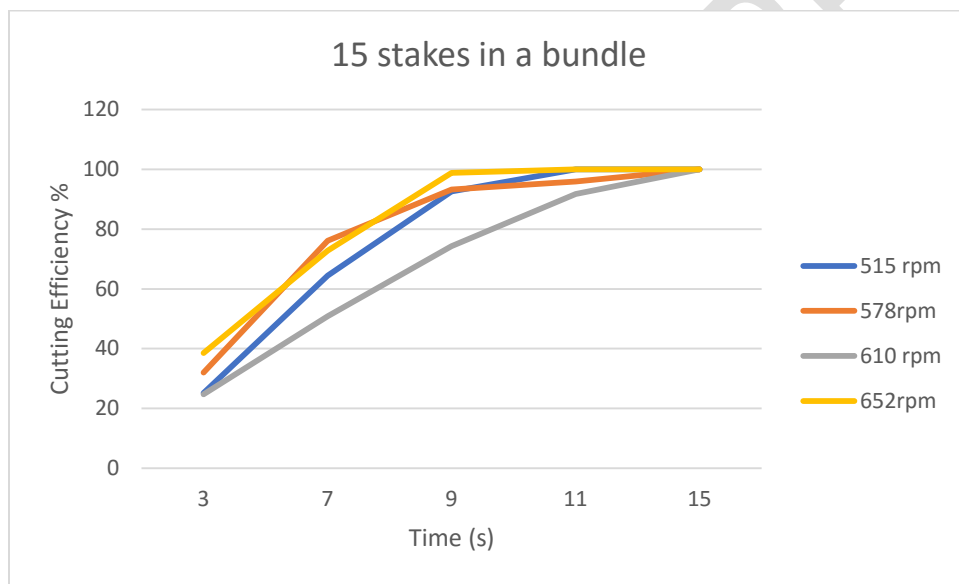

Figure 7. Effect of time on efficiency for various cutting speeds

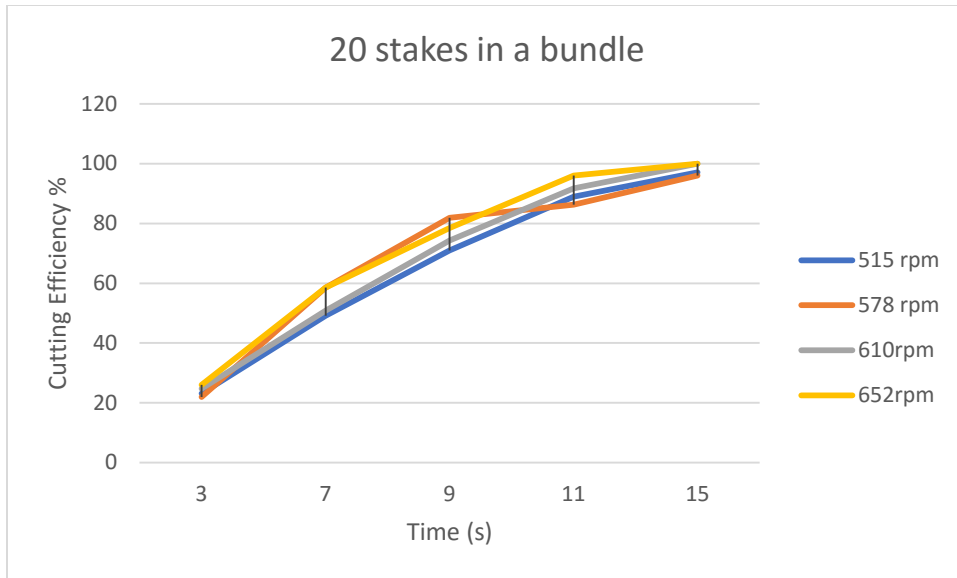

Figure 8. Effect of time on efficiency for various cutting speeds

Figure 5 shows that at 515 rpm speed, the cutting efficiency starts above 80% with 3 seconds into cutting, then gradually increases close to 100% in the space of 3.5 – 4 seconds. The experience is similar for speeds of 578 and 610 rpm. Under the 652rpm speed, it can be observed that the cutting efficiency starts at 100% and maintains the efficiency throughout the period.

Figure 6 shows that at 515 rpm speed, the cutting efficiency starts above 40 % during 3 seconds into cutting and increases close to 100% during 4 seconds, and then eventually reaches to 100% in about 4 seconds later. Almost the same experience is observed for speeds of 578 and 610 rpm. Under the 652 rpm, the experience is again similar except that cutting efficiency starts at 60% under 3 seconds and reaches 100% 4 seconds later while maintaining this efficiency throughout. An increase in the stakes in a bundle decreased the starting cutting efficiency of the machine while taking a long time to achieve 100% cutting efficiency.

Figure 7

Figures 5, 6, 7 and 8 above shows that there was a significant increase in cutting efficiency as the cutting blade speeds were increased.

Also, the figures show that an increase in residence time had a significant impact on the machines cutting efficiency across all the bundles fed into the machine. 20 stakes with variable stem diameters in a bundle were the maximum capacity the machine can take per batch and it gave the highest cuttings of 19,000/hour which is enough to meet IITA's recommended planting spacing requirement of 1 m × 0.8 m which will give a plant population of 12,500 stands/hectare. However, The machine was capable to cut the stem for a hector in a hour.

4.0 Conclusion

The machine's cutting efficiency was 100% meaning it gave the desired number of cuttings at its maximum capacity. This is very satisfactory, so we recommend the machine for medium scale production of cassava stakes to promote cassava production.

References

1. Asoegwu S.N. (1998). Agricultural Field Implement and Mechanization. Ambix Printers, Nigeria. 2:5-6
3. Chiona M, Ntawuruhunga P, Mukuka I, Chalwe A, Phiri N, Chikoti P and Simwambana M. 2016. Growing Cassava: Training Manual for Extension and Farmers in Zambia. International Institute of Tropical Agriculture (IITA), Zambia.
<https://cgspace.cgiar.org/bitstream/handle/10568/91027/U16ManChionaCassavaNothomDev.pdf?sequence=1&isAllowed=y> Accessed 27 September 2019

2. Ezedinma C I, Kormawa P M, Manyong V M and Dixon A G O. Challenges, opportunities, and strategy for cassava sub-sector development in Nigeria. International Institute of Tropical Agriculture, Ibadan, Nigeria. Proceedings of the 13th ISTRC Symposium, 2007 pp.627 - 640
3. FAO (2017). "Cassava production in 2016, Crops/World Regions/Production Quantity from pick lists". UN Food and Agriculture Organization Corporate Statistical Database (FAOSTAT).
 1. Peerasak Sanguansri (2007). Cutting techniques for minimally processed vegetables. Food Australia. 49 (3) 135 – 138 <https://www.researchgate.net/publication/233936729>
 2. Vegetative Propagation Techniques. Perennial Crop Support Series Jalalabad, Afghanistan Publication No. 2007-003-Afg November 18, 2007
4. Ratanawaraha C, Senanarong N and Suriyapan P. Status of Cassava in Thailand: Implications for Future Research and Development. International Fund for Agricultural Development (BFAD) Rome, Italy <http://www.fao.org/3/y1177e/Y1177E04.htm>
5. Yazdan Kordestany and Yongsheng Ma. Force calculation using analytical and CAE methods for the thin-blade slotting process. Kordestany & Ma, Cogent Engineering (2017), 4: 1-14 <https://doi.org/10.1080/23311916.2017.1412106> Retrieved 29 September 2019
6. Tarawali G, Ilona P, Ojiako I A, Iyangbe C, Ogundijo D S, Asumugha G, and Udensi U E. A comprehensive training module on competitive cassava production. IITA, Ibadan, Nigeria. 40 pp.
7. <https://www.telegraph.co.uk/news/earth/earthnews/9345086/The-worlds-fattest-countries-how-do-you-compare.html> Retrieved 29 September 2019

8. <http://www.fao.org/3/X5032E/x5032E01.htm> Accessed on 17 February 2020
9. https://www.uq.edu.au/School_Science_Lessons/CasProj.html Accessed on 17 February 2020

UNDER PEER REVIEW