

Original Research Article

Relational Analysis between Profile of Kisan Credit Card Scheme

Beneficiary Farmers and Impact of Kisan Credit Card Scheme

ABSTRACT

The present investigation was conducted in Latur and Osmanabad district of the Marathwada region during the year 2020 and 2021 which was selected purposively on the basis of maximum number of Kisan Credit Card Scheme beneficiary farmers. Ex-post-facto research design was adopted in this study. The data were collected with the help of pretested interview schedule from the respondents and analysed by using Pearson's coefficient of correlation, multiple regression analysis and Path analysis. It was observed from correlation analysis that education, annual income, occupation, land holding, social participation and extension contact were positively and significantly related with the impact of KCC Scheme while sources of information, economic motivation, risk orientation and knowledge were positive and highly significant relationship with the impact of KCC Scheme. The variable namely age, size of family and type of family were non-significant with the impact of KCC Scheme. It was observed from multiple regression analysis that co-efficient of determination (R^2) of the independent variables was 0.778. The value of 't' showed that impact of KCC Scheme was significantly related with education, annual income, occupation, land holding, extension contact, sources of information, economic motivation, risk orientation and knowledge. In relation to path analysis, it was observed that, sources of information, extension contact, education, knowledge, land holding, annual income, social participation, age, occupation and risk orientation were important variables in absence of which independent variables are not able to influence the impact of KCC Scheme on its beneficiaries.

(Key words: Kisan credit card scheme, Beneficiary farmers, Correlation, Multiple regression analysis, Path analysis, Impact.)

1. INTRODUCTION

Credit is most crucial in agriculture to increase agriculture productivity. Agricultural financing is critical to the development of the farm industry and the adoption of new technology. It assists in the maintenance of agricultural production by allowing producers to meet their comprehensive credit requirements throughout the crop production cycle while also providing funds for investment. Kisan Credit Card (KCC) scheme was first proposed in the financial year 1998-99 Budget, with the objective of providing short term credit to farmers to meet their immediate credit needs during the crop season. Consequent to this a Model KCC scheme was prepared by the NABARD to provide term loans for agricultural needs. According to need of credit for agriculture and allied sector development, KCC scheme was launched in August 1998 by GOI, RBI and NABARD to simplify credit delivery mechanism with the aim of providing short term formal credit to farmers on the basis of their land holding, cropping pattern and scale of finance, so that the farmers may use them for purchase of agriculture inputs such as seeds, fertilizers and pesticides etc. and also drawn cash for their production needs. The government of India gives KCC loans up to Rs. 1.6 lakh without guarantee to small farmers having KCC. Now a days KCC not limited to farming only. The scheme was further extended for the investment credit requirement viz. allied activities and non-farm activities in 2004 and by 2019 for fisheries and animal husbandry giving financial support up to Rs. 2 lakh to farmers.

Basically, KCC is a cash credit facility sanctioned to farmer for various farming needs. Farmer can avail the credit when cropping season starts for purchasing of cultivation needs and repayment made after harvesting when the crop is sold. The credit limit sanctioned on the basis of cultivated area, cropping pattern and irrigation facility. All farmers including

small farmers, marginal farmers, tenant farmers, share croppers and landless labourers are eligible to be covered under the scheme. The KCC holders are covered under Personal Accident Insurance Scheme up to Rs. 50,000 against accidental death or permanent disability and up to Rs. 25,000 for other risk. The scheme aims at providing adequate and timely credit for the comprehensive credit requirements of farmers under single window for their cultivation and other needs. Hence KCC Scheme is an important government policy initiative to provide institutional credit for the agriculture sector.

2. MATERIALS AND METHODS

The present study was conducted in Marathwada region of Maharashtra state during the year 2020 and 2021.

2.1 Research Design

This study used an ex-post facto research design. Because independent variables are intrinsically non-manipulable, ex-post facto research design is a systematic empirical investigation in which the researcher does not have direct control over them [1].

2.2 Method of Sampling

A multistage sampling technique was used for the study. Sampling was done at four stages viz., the selection of districts, selection of talukas, selection of villages and selection of respondents.

2.2.1 Selection of Districts

The present study was conducted in purposively selected Two districts viz., Latur and Osmanabad districts of Marathwada region of Maharashtra state on the basis of maximum number of KCC scheme beneficiary farmers were found in these two districts out of total eight districts of Marathwada region.

2.2.2 Selection of Talukas

The purposively selection of talukas were done from the selected districts on the basis of maximum number of KCC scheme beneficiary farmers. There are ten talukas in Latur district out of that three talukas were selected namely Latur, Ausa and Nilanga. From Osmanabad district, selected three talukas namely Tuljapur, Osmanabad and Umarga out of eight talukas. Thus, total six talukas were selected from the two districts for the study.

2.2.3 Selection of Villages

From each selected taluka 4 villages were selected purposively on the basis of list obtained from Bank and co-operative society having KCC scheme beneficiary farmers. Thus, total 24 villages were selected from the 6 talukas.

2.2.4 Selection of Respondents

From each selected village 5 KCC scheme beneficiary farmers were selected purposively from mass beneficiaries who are using KCC since last five years at the time of data collection. Thus, total 120 respondents were selected for the study.

2.4 Statistical Tools and Techniques

The data were collected with the help of pretested interview schedule from the respondents as per their convenience at their home or farm. The collected data was analysed by using following statistical techniques

2.4.1 Pearson's coefficient of correlation

Pearson's correlation coefficient (r) was used to find out zero order correlation between dependent and independent variables to see the nature of relationship existed.

$$r = \frac{N\sum XY - \sum X \sum Y}{\sqrt{[N\sum X^2 - (\sum X)^2][N\sum Y^2 - (\sum Y)^2]}}$$

2.4.2 Multiple regression analysis

The technique was used to know the partial and complete influence of independent variables on dependent variable. For the present study, linear model of regression equation was used as follows.

$$Y_1 = a + b_1x_1 + b_2x_2 + \dots + b_nx_n + \mu$$

2.4.3 Path analysis

This was used to identify the direct, total indirect, total effect and substantial indirect effect of independent variables on dependent variable.

Path analysis adopting multivariate path model suggested by Land [2] was used to isolate direct, total indirect, total effect and substantial indirect effect of independent variables on dependent variable of the respondents.

The formula used was as follows,

$$Z_{12} = P_{12.1} Z_1 + P_{12.2} Z_2 + \dots + P_{12.n} Z_n + P_{12.Za}$$

3. RESULTS AND DISCUSSION

3.1 Correlation analysis between profile of KCC Scheme beneficiary farmers and Impact of KCC Scheme

Correlation analysis between profile of KCC Scheme beneficiary farmers and **Impact of KCC Scheme**

Pictorial presentation given in Fig. 1.

Table 1: Relationship between profile of KCC Scheme beneficiaries and overall impact of KCC Scheme

Sr. No.	Independent Variables	Correlation coefficient (r)
---------	-----------------------	-----------------------------

1.	Age	0.088 ^{NS}
2.	Education	0.221 [*]
3.	Size of Family	-0.054 ^{NS}
4.	Type of Family	0.029 ^{NS}
5.	Annual Income	0.201 [*]
6.	Occupation	0.227 [*]
7.	Land Holding	0.231 [*]
8.	Social Participation	0.199 [*]
9.	Extension Contact	0.223 [*]
10.	Sources of Information	0.259 ^{**}
11.	Economic Motivation	0.283 ^{**}
12.	Risk Orientation	0.261 ^{**}
13.	Knowledge	0.257 ^{**}

NS- Non-significant * - Significant at 0.05 % level ** - Significant at 0.01 % level

3.1.1 Age with Impact of KCC Scheme

It was revealed from Table 1 that, there was positive and non-significant (0.088) relationship between age of KCC Scheme beneficiaries and impact of KCC Scheme. It means that, age of the KCC Scheme beneficiaries does not impact on its beneficiaries. There was no any relationship of age with overall impact of KCC Scheme. Hence null hypothesis accepted. The findings are similar to Nargaven [3], Sekhon [4], Sharma [5] and Verma [6].

3.1.2 Education with Impact of KCC Scheme

It was revealed from Table 1 that, there was positive and significant (0.221) relationship between education of KCC Scheme beneficiaries and impact of KCC Scheme. Education has profound impact on every aspect of life of beneficiaries. It increases the knowledge and awareness about the KCC Scheme. It was assumed that educated

beneficiaries might have more impact. Hence null hypothesis rejected. The findings are similar to Nargaven [3], Sharma [5], Dawar [7], Pramod Parwate [8], Verma [6], Malviya [9] and Kshama [10].

3.1.3 Size of Family with Impact of KCC Scheme

It was revealed from Table 1 that, there was negative and non-significant (-0.054) relationship between size of family of KCC Scheme beneficiaries and impact of KCC Scheme. More the members in the family may create the conflicts about the various decision making and creates the confusion which causes the less impact. It means that size of family doesn't affect on the impact of KCC Scheme on its beneficiaries. Hence null hypothesis accepted. The findings are similar to Sharma [5], Pramod Parwate [8] and Nishad [11].

3.1.4 Type of Family with Impact of KCC Scheme

It was revealed from Table 1 that, there was positive and non-significant (0.029) relationship between type of family of KCC Scheme beneficiaries and impact of KCC Scheme. As type of family was nuclear, it means that type of family doesn't affect on the impact of KCC Scheme on its beneficiaries. Hence null hypothesis accepted. The findings are similar to Sekhon [4] and Dawar [7].

3.1.5 Annual Income with Impact of KCC Scheme

It was revealed from Table 1 that, there was positive and significant (0.201) relationship between annual income of KCC Scheme beneficiaries and impact of KCC Scheme. It means that increase in annual income of KCC Scheme beneficiaries there was increase in impact of KCC Scheme. Annual income provides economic stability for KCC Scheme beneficiaries and make them aware about purchasing essential inputs at time required for different farming operations. It helps to increase risk orientation and standard of living of the beneficiaries. Hence null hypothesis rejected. The findings are similar to Sekhon [4], Sharma [12], Dawar [7], Verma [6], Malviya [9], Nishad [11] and Bhosale [13].

3.1.6 Occupation with Impact of KCC Scheme

It was revealed from Table 1 that, there was positive and significant (0.227) relationship between occupation of KCC Scheme beneficiaries and impact of KCC Scheme. Occupation is directly related with the KCC Scheme beneficiaries. KCC Scheme beneficiaries with farming had created more employment opportunities from allied enterprises which helps to increase net income of the beneficiaries. Increase in net income of the beneficiaries there was increase in impact of KCC Scheme. Hence null hypothesis rejected. The findings are similar to Nargaven [3], Sharma [12], Verma [6], Nishad [11] and Bhosale [13].

3.1.7 Land Holding with Impact of KCC Scheme

It was revealed from Table 1 that, there was positive and significant (0.231) relationship between land holding of KCC Scheme beneficiaries and impact of KCC Scheme. Many of the beneficiaries had small and semi-medium land holding. Credit is very important factor in farming. KCC Scheme provides the loan for cultivation purpose which helps to increase the crop production and resulted in increased annual income. Hence there was significant relationship between land holding of the beneficiaries and impact of KCC Scheme. Hence null hypothesis rejected. The findings are similar to Nargaven [3], Dawar [7], Verma [6], Malviya [9], Shridevi Valamannavar [14] and Bhosale [13].

3.1.8 Social Participation with Impact of KCC Scheme

It was revealed from Table 1 that, there was positive and significant (0.199) relationship between social participation of KCC Scheme beneficiaries and impact of KCC Scheme. KCC Scheme beneficiaries participate more in different organizations due to their personal interest. Therefore, due to this there might be positive and significant relationship between social participation and impact of KCC Scheme. Hence null hypothesis rejected. The

findings are similar to Sekhon [4], Sharma [5], Dawar [7], Rajput [15], Pramod Parwate [8], Guthriya [16], Jat [17], Patidar [18] and Bhosale [13].

3.1.9 Extension Contact with Impact of KCC Scheme

It was revealed from Table 1 that, there was positive and significant (0.223) relationship between extension contact of KCC Scheme beneficiaries and impact of KCC Scheme. More extension contact with the different extension personnel helps for increasing their knowledge and awareness about KCC Scheme. Due to this there was significant relationship between extension contact and impact of KCC Scheme. Hence null hypothesis rejected. The findings are similar to Dawar [7], Verma [6], Bhavani Gottemukkula [19], Shridevi Valamannavar [14] and Bhosale [13].

3.1.10 Sources of Information with Impact of KCC Scheme

It was revealed from Table 1 that, there was positive and highly significant (0.259) relationship between sources of information of KCC Scheme beneficiaries and impact of KCC Scheme. KCC Scheme beneficiaries had more exposed to different sources of information to get more amount of information and knowledge. They use more sources of information which establish significant relationship with the impact of KCC Scheme. Hence null hypothesis rejected. The findings are similar to Guthriya [16] and Nishad [11].

3.1.11 Economic Motivation with Impact of KCC Scheme

It was revealed from Table 1 that, there was positive and highly significant (0.283) relationship between economic motivation of KCC Scheme beneficiaries and impact of KCC Scheme. KCC Scheme beneficiaries had more economic stability than the non-beneficiaries which resulted in more economic motivation. It means that increasing economic motivation of the KCC Scheme beneficiaries will helps to increase in impact of KCC Scheme. Hence null hypothesis rejected. The findings are similar to Nargaven [3], Sekhon [4], Pramod Parwate [8], Verma [6], Nishad [11] and Bhosale [13].

3.1.12 Risk Orientation with Impact of KCC Scheme

It was revealed from Table 1 that, there was positive and highly significant (0.261) relationship between risk orientation of KCC Scheme beneficiaries and impact of KCC Scheme. KCC Scheme beneficiaries had more risk orientation and always ready to face the challenges to get maximum returns due to which there was significant relationship with the impact of KCC Scheme. Hence null hypothesis rejected. The findings are similar to Nargaven [3], Verma [6], Nishad [11], Bhavani Gottemukkula [19] and Bhosale [13].

3.1.13 Knowledge with Impact of KCC Scheme

It was revealed from Table 1 that, there was positive and highly significant (0.257) relationship between knowledge of KCC Scheme beneficiaries and impact of KCC Scheme. Education, social participation in organizations, different sources of information and more extension contact of the beneficiaries helps to increase their knowledge level about KCC Scheme. Therefore, it means that more the knowledge helps to increase the impact of KCC Scheme. Hence null hypothesis rejected. The findings are similar to Sharma [12], Dawar [7], Rajput [15], Guthriya [16], Hirwe [20], Jat [17] and Patidar [18].

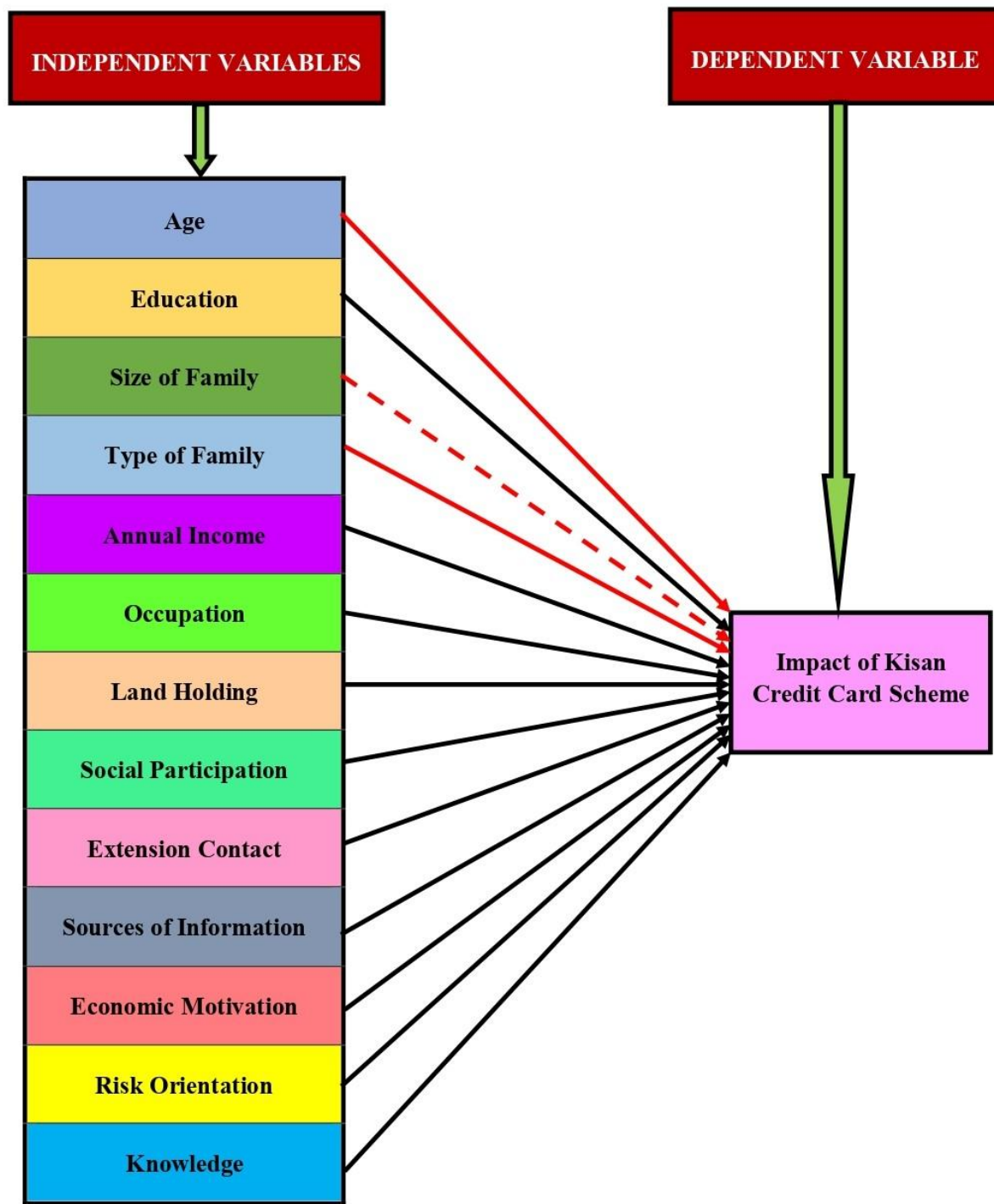

- Significant
- Non-significant
- - -→ Negatively Non-significant

Fig. 1: Empirical model showing relationship between independent variables with dependent variable i.e. Impact of KCC Scheme

3.2 Multiple regression analysis

Multiple regression analysis was calculated to know the combine effect of all thirteen independent variables in explaining the dependent variable i.e. impact of KCC Scheme and presented in Table 2.

Table 2: Multiple regression analysis between profile of the KCC Scheme beneficiaries and overall impact of KCC Scheme

Sr. No.	Independent Variables	Regression coefficient (Bi)	Standard Error (S.E.)	't' value
1.	Age	0.553	0.454	1.218 ^{NS}
2.	Education	0.246	0.111	2.187*
3.	Size of Family	-0.516	0.182	-1.079 ^{NS}
4.	Type of Family	-0.635	0.528	-0.466 ^{NS}
5.	Annual Income	0.351	0.165	2.107*
6.	Occupation	0.093	0.035	1.758*
7.	Land Holding	0.084	0.700	2.139*
8.	Social Participation	0.176	0.044	1.409 ^{NS}
9.	Extension Contact	0.035	0.017	2.015*
10.	Sources of Information	0.455	0.218	3.427**
11.	Economic Motivation	1.476	0.644	3.534**
12.	Risk Orientation	0.857	0.638	2.932**
13.	Knowledge	0.513	0.444	2.669**

$R^2 = 0.778$

F = 04.87

NS = Non-Significant

* - Significant at 0.05 % level

** - Significant at 0.01 % level

It was revealed from Table 2 that, co-efficient of determination (R^2) of the independent variables was 0.778. It means that 77.80 per cent of the total variation in the impact of KCC Scheme on its beneficiaries was explained by the selected 13 independent variables. The unexplained variation may be due to the factors not included in the study. It is also may be due to certain factors which were out of the scope of present study.

The value of 't' showed that impact of KCC Scheme was significantly related with education, annual income, occupation, land holding, extension contact, sources of information, economic motivation, risk orientation and knowledge.

The regression coefficients of these variables were 0.246, 0.351, 0.093, 0.084, 0.035, 0.455, 1.47, 0.857 and 0.513 respectively which indicates that one unit change in the variables viz., age, size of family, type of family and social participation would affect 0.246, 0.351, 0.093, 0.084, 0.035, 0.455, 1.47, 0.857 and 0.513 unit change in impact of KCC Scheme.

The overall contribution of all the selected 13 independent variables in impact of KCC Scheme was found 77.80 per cent. Hence, 9 variables were found most important variables in exercising influence on impact of KCC Scheme on its beneficiaries.

3.3 Path analysis

Path analysis were attempted in order to know the influence of independent variables both directly as well as through other variables. Analysed data presented in Table 3 and pictorial presentation given in Fig. 2.

Table 3: Path analysis showing the effects of profile of KCC Scheme beneficiaries with overall impact of KCC Scheme

Sr. No.	Independent variables	Total effect	Direct effect	Total indirect	Substantial indirect effect

				effect	1	2
X1	Age	0.181	0.0553	0.1257	0.0103 (X13)	0.0088 (X6)
X2	Education	0.221	0.1891	0.0319	0.0506 (X5)	0.0488 (X6)
X3	Size of Family	-0.0548	-0.0913	0.0365	0.016 (X6)	0.011 (X11)
X4	Type of Family	0.0296	0.099	-0.0694	0.0716 (X3)	0.0094 (X7)
X5	Annual Income	0.1754	0.0152	0.1602	0.0095 (X7)	0.0078 (X6)
X6	Occupation	0.1596	0.0719	0.0877	0.037 (X5)	0.0185 (X2)
X7	Land Holding	0.185	0.1495	0.0355	0.0933 (X5)	0.0227 (X4)
X8	Social Participation	0.1358	0.0512	0.0846	0.0212 (X13)	0.0132 (X10)
X9	Extension Contact	0.2238	0.0684	0.1554	0.0518 (X10)	0.0449 (X13)
X10	Sources of Information	0.2596	0.2033	0.0563	0.1539 (X9)	0.1172 (X13)
X11	Economic Motivation	0.1576	-0.0676	0.2252	0.0082 (X3)	0.0046 (X4)
X12	Risk Orientation	0.1704	0.0448	0.1256	0.0315 (X11)	0.0234 (X9)

X13	Knowledge	0.1897	0.0651	0.1246	0.0036 (X1)	0.0016 (X5)
-----	-----------	--------	--------	--------	----------------	----------------

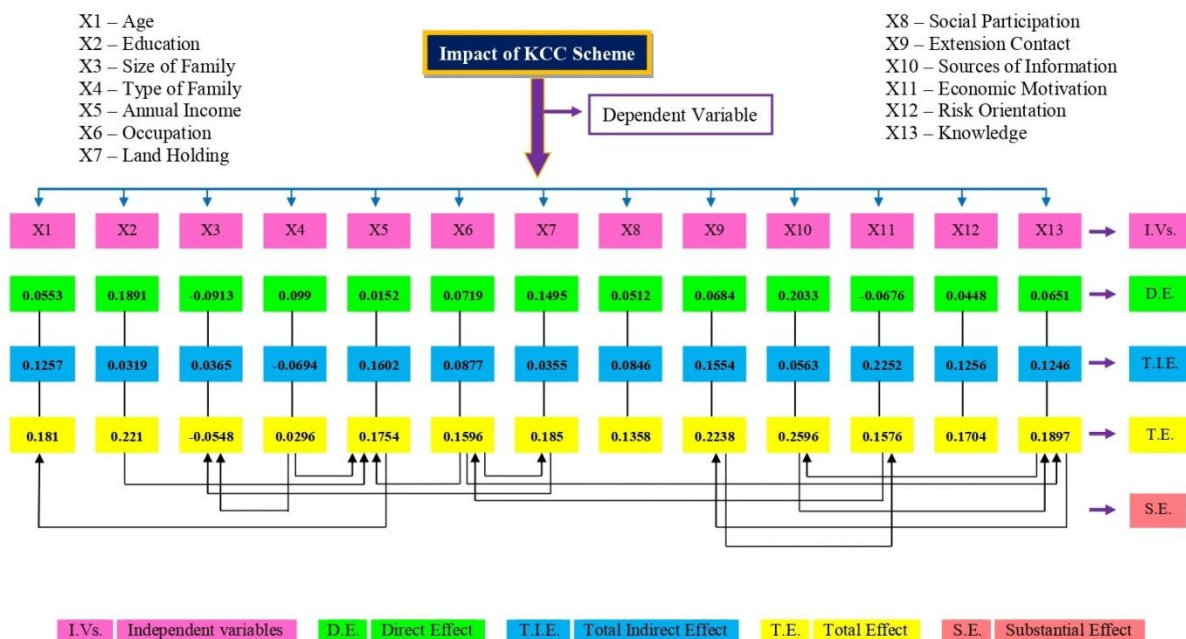

Fig. 2: Path analysis showing the effects of profile of the KCC Scheme beneficiary farmers on their overall impact of KCC Scheme

1. Total effect

It was revealed from Table 3 that, the highest positive total effect on overall impact of KCC Scheme on its beneficiaries was exerted by sources of information, followed by extension contact, education, knowledge, land holding, age, annual income, risk orientation, occupation, economic motivation, social participation and type of family. It means that total of the direct effect and indirect effect exerted by all independent variables on overall impact of KCC Scheme.

2. Direct effect

It was revealed from Table 3 that, the highest positive direct effect on overall impact of KCC Scheme on its beneficiaries was exerted by sources of information, followed by education, land holding, type of family, occupation, extension contact, knowledge, age, social participation, risk orientation and annual income.

3. Total indirect effect

It was revealed from Table 3 that, the highest positive total indirect effect on overall impact of KCC Scheme on its beneficiaries was exerted by economic motivation, followed by annual income, extension contact, age, risk orientation, knowledge, occupation, social participation, sources of information, size of family, land holding and education.

4. Substantial indirect effect

It was revealed from Table 3 that, the highest positive first substantial indirect effect on overall impact of KCC Scheme on its beneficiaries was exerted by sources of information through extension contact, followed by land holding through annual income, type of family through size of family, extension contact through sources of information, education through annual income, occupation through annual income, risk orientation through economic motivation, social participation through knowledge, size of family through occupation, age through knowledge, annual income through land holding, economic motivation through size of family and knowledge through age.

It further shows that, highest positive second substantial indirect effect on overall impact of KCC Scheme on its beneficiaries was exerted by sources of information through knowledge, followed by education through occupation, extension contact through knowledge, risk orientation through extension contact, land holding through type of family, occupation through education, social participation through sources of information, size of family through economic motivation, type of family through land holding, age through occupation, annual income through occupation, economic motivation through type of family and knowledge through annual income.

Thus, it was observed that, sources of information, extension contact, education, knowledge, land holding, annual income, social participation, age, occupation and risk

orientation were important variables in absence of which independent variables are not able to influence the impact of KCC Scheme on its beneficiaries.

4. CONCLUSIONS

Education, annual income, occupation, land holding, social participation, and extension contact were found to be positively and significantly related to the impact of the KCC Scheme, whereas sources of information, economic motivation, risk orientation, and knowledge were found to have a positive and highly significant relationship with the impact of the KCC Scheme. The variable namely age, size of family and type of family were non-significant with the impact of KCC Scheme. Co-efficient of determination (R^2) of the independent variables was 0.778. It means that the overall contribution of all the selected 13 independent variables in impact of KCC Scheme was found 77.80 per cent.

5. IMPLICATION

Extension workers, banking personnel and policy makers should consider these attributes which help to increase effective implementation or impact of KCC Scheme by farmers.

Consent

As per international standard or university standard, respondents' written consent has been collected and preserved by the author(s).

REFERENCES

1. Kerlinger, F. N. Foundation of behavioural research. New Delhi: Surjeet Publication; 1976.
2. Land. Principles of path analysis. Sociological methodology Edgar, F. Bargatta (Eds.) Jossey Ban San Francisco; 1969: 37.

3. Nargaven, M. K. Study on Utilization Pattern of Kisan Credit Card among Tribal farmers for Agricultural Development in Manpur block of Umaria District, M.P. M.Sc. Thesis, Jawaharlal Nehru Krishi Vishwa Vidyalaya, Jabalpur; 2010.
4. Sekhon, G. A study on repayment behavior of beneficiaries of Kisan Credit Card (KCC) scheme in Betul block of Betul district of M.P. M.Sc. Thesis, Rajmata Vijayaraje Scindia Krishi Vishwa Vidyalaya, Gwalior; 2010.
5. Sharma, A. A study on impact of Kisan Credit Card Scheme among the beneficiary farmers in Sehore district of Madhya Pradesh. M.Sc. Thesis, Rajmata Vijayaraje Scindia Krishi Vishwa Vidyalaya, Gwalior; 2010.
6. Verma, A. A critical analysis of Utility of Kisan Credit Card as perceived by Marginal and Small Farmers in Sidhi block of Sidhi District (M.P.). M.Sc. Thesis Jawaharlal Nehru Krishi Vishwa Vidyalaya, Jabalpur; 2016.
7. Dawar, G. A study on Repayment Behaviour of Kisan Credit Card users of Thikari block, Barwani district of Madhya Pradesh. M.Sc. Thesis Jawaharlal Nehru Krishi Vishwa Vidyalaya, Jabalpur; 2011.
8. Pramod Parwate¹, M. L. Sharma¹ and Mahesh Maske². A study on utilization pattern of Kisan Credit Card (KCC) among the farmers in Raipur district of Chhattisgarh. International Journal of Agronomy and Plant Production 2012; 3 (2) : 54-58.
9. Malviya, A. A study on Repayment Behaviour of Kisan Credit Card users of Shajapur Bolck of Shajapur District M. P. M.Sc. Thesis Rajmata Vijayaraje Scindia Krishi Vishwa Vidyalaya, Gwalior; 2017.
10. Kshama A. V.¹, Santha A. M.², Paul Lazarus T.³ and Brigit Joseph⁴. Socio-Economic Profile of Kisan Credit Card holders in Thiruvananthapuram District. International

Journal for Research in Applied Science and Engineering Technology 2018; 6 (5) : 2859-2866.

11. Nishad, T. L. Utilization pattern of Kisan Credit Card among the small and marginal farmers in Rewa block of Rewa District, M. P. M.Sc. Thesis, Jawaharlal Nehru Krishi Vishwa Vidyalaya, Jabalpur; 2017.
12. Sharma, P. A Study on Credit Utilization Pattern of Crop loan beneficiaries through co-operative society of Bhind Block of Bhind District (M.P.) M.Sc. Thesis, Rajmata Vijayaraje Scindia Krishi Vishwa Vidyalaya, Gwalior; 2010.
13. Bhosale, G. S. Crop loan borrowing behaviour of farmers M.Sc. Thesis. Vasantrao Naik Marathwada Krishi Vidyapeeth, Parbhani; 2019.
14. Shridevi Valamannavar¹, Anindita Saha² and D. S. Dhakre³. A study on Knowledge and opinion of the farmers regarding Kisan Credit Card Scheme in Dharwad District of Karnataka. International Journal of Agricultural Science and Research 2018; 8 (6) : 25-32.
15. Rajput, J. S. A study on Repayment Behaviour of Crop loan beneficiaries of Budhani Block of Sehore district, Madhya Pradesh. M.Sc. Thesis Rajmata Vijayaraje Scindia Krishi Vishwa Vidyalaya, Gwalior; 2011.
16. Guthriya, G. A study on Repayment Behaviour of Crop Loan Beneficiaries of Jobat Block of Alirajpur District, Madhya Pradesh. M.Sc. Thesis Rajmata Vijayaraje Scindia Krishi Vishwa Vidyalaya, Gwalior; 2015.
17. Jat, R. A study on socio-economic change among the beneficiaries farmers of crop loan scheme in Dewas district of Madhya Pradesh. M.Sc. Thesis, Rajmata Vijayaraje Scindia Krishi Vishwa Vidyalaya, Gwalior; 2016.

18. Patidar, M. Impact analysis of Credit Through District Co-operative Bank on agricultural development of beneficiary farmers in Ratlam District of M. P. M.Sc. Thesis, Rajmata Vijayaraje Scindia Krishi Vishwa Vidyalaya, Gwalior; 2017.
19. Bhavani Gottemukkula*, Mankar D. M. and Bhople P. P. Utilization pattern of crop loan by the farmers in Akola district. International Journal of Agriculture Sciences 2018; 10 (6) : 5558-5560.
20. Hirwe, R. A study on Impact of Kisan Credit Card Scheme among the Beneficiary Farmers in Maheshwar block, Khargone District of M.P. M.Sc. Thesis Rajmata Vijayaraje Scindia Krishi Vishwa Vidyalaya, Gwalior; 2016.

UNDER PEER REVIEW