

Original Research Article

Art Paper for Large Wood Relief Block Printing – A Paper Development Study

ABSTRACT

Wood relief block printing was developed in China in the seventh century and is used today for many art printing applications. The presented research project describes the development of an art paper product applicable for large wood ~~relieve~~-relief block printing from laboratory scale to large semi commercial production of art paper for printing image sizes of up to 44-inch (1118 mm) by 96-inch (2400 mm) at outdoor steam roller printing events or smaller indoor printing press applications.

The improvement of the paper properties from laboratory development, small laboratory paper machine and semi commercial paper machine run for the production of the final art paper showed an improvement throughout the process development for the optical and mechanical paper properties, and exceeded the set values set by the artist using the art paper.

The produced art paper with a basis weight of 260 g/m² and a thickness of 171 μm is produced from a mixture of 70% northern bleached hardwood Kraft pulp and 30% northern bleached softwood Kraft pulp.

The ISO brightness of the art paper off-white (egg-shell) colour was at 63.2%, and the ISO color value for L, a, b, at 90.8, 1.1, and 12.6 respectively.

The art papers surface roughness and porosity as a parameter for ink attachment and penetration is, for the top side, 2179 ml/min and ~~for the~~ bottom side (wire side) 2326 ml/min, whereas porosity was measured at 1668 ml/min.

Bending stiffness in machine direction and cross machine direction ~~was measured~~ at 157mN and 70 mN, respectively. Burst strength was measured at 2.24 kPa·m²/g ~~respectively~~.

Keywords: Art paper, papermaking, paper machine, printing, wood relief block printing

1. INTRODUCTION

Over centuries, paper making knowledge ~~has~~ traversed continents. Similarly, woodblock printing technology followed a path from China, through the Middle East and Europe, arriving lastly in the New World. It took hold in Japan, Korea, and India as well. A 1966 discovery of a printed scroll in Korea set off a debate about the origin of woodblock printing [1]. The definitive consensus recognizes the technology was developed in China in the seventh century. This article explores how woodblock can be used for printing on paper. In various parts of the world, the technology was used slightly differently.

Painstakingly writing text or drawing images on paper by hand was perceived as an art only few could afford. The woodblock allows the printing to be repeated, making it both easier to reproduce the message and to facilitate the distribution. Towards the East, woodblock printing migrated early to Korea and Japan. The Japanese needed a higher quality paper for this printing technique. They developed specialty papers that are more absorbent and

worked better than the Chinese paper [2]. It is important to size the paper and to ensure the correct amount of dampness. The formation of Japanese paper consists of shaking the deckle to ensure a more effective distribution of the fibers. Japanese papers are fabricated specially for water-based inks and are smoother than their Chinese counterparts.

To the West, woodblock printing is more often found in India as a method to print textiles. Woodblock is used to make the patterns that repeated around the material, while hand painted designs were found on other parts of the fabric [3]. As in Japan, Indian artisans use an experienced arm technique to apply pressure to the woodblock to reproduce the pattern. Japanese woodblock printing continues to enthrall newcomers, as was the case in Pakistan in 2014 where the art was taught through a seminar at the embassy [4].

Before the appearance of letter block printing, the only way to transfer written text was to transcribe one document at a time, except that Bulliet proposes that this is not entirely accurate [5]. Prior to secular texts, the earliest writings were religious. This was also true in the Middle East, where tin may have replaced the wood blocks but achieved the same goal, to produce poems and verses of the Koran. These black and white prints were extremely tiny. The rolled-up papers were known as amulets printed from tarsh (print blocks) and Egyptians hung them around their necks, according to Bulliet [5].

In fact, this was considered an underground avenue for ordinary people to feel that they too could enjoy the printed word at an affordable price. It is believed that this manner of printing was supplanted by the arrival of the printing press in Turkey. Introduced by China, this ~~middle-Middle E~~eastern technology spread to Germany and France, where we see the continuity of the notion of “engraver”, suggesting that relief printing techniques were in fact used.

It took from the sixth century in the Near East until the 1400s for book illustrations to be used as art by English printer William Caxton [6]. ~~As it was in~~ Egypt, woodcuts were considered unimportant and cheap, but popular, as reported by Cummins [6]. Famous literary works were illustrated by wood block printing, including Charles Dickens in 1828, *Alice’s Adventure in Wonderland* in 1865 and *Through the Looking Glass* in 1871. At this point, photography overcame the wood block printing, but *Wuthering Heights* (1943) continued in the woodblock tradition.

Digi-woodcut is a new form of art which scans ~~in~~ wood textures into paintings [6]. Historically, blocks of wood were cuts, so that the grain ran lengthwise [6]. In the West, oil-based inks are the convention, whereas in Japan the inks are water-based and more difficult to reproduce by outsiders. Hardwood expresses in its nomenclature that it is harder to cut. However, this hardness contributes to durability and sharper detailing, with or against the grain. In contrast, softwood enhances texture. The result of the printing is influenced by the direction of the grain [7].

Ahead of the English novels, Bavarian printer Albrecht Pfister was first to illustrate the Latin Bible. In Germany and the Netherlands, wood block printing was short-lived, supplanted by engraving on metal a century later, much as ~~it~~ happened in the East. Although the technique was used to print the Koran and the Bible, in China, the opposite occurred, in that vernacular texts were subject to block printing. According to McLaren [8], sino-xylography reigned until the early twentieth century, ~~until when~~ Western methods of lithography was adopted.

There are two categories of printing. They are the reverse of each other. The first is *intaglio*, an Italian word which means to cut in. In this case, the material is usually a metal. The inks sink into the parts that were etched away. ~~T~~he ink is then transferred by the printing process ~~what~~ to the paper, producing an image. By contrast, wood engraving is accomplished by the artist by cutting away the parts of the wood where ink is not desired, and the ink is applied to the remaining surface and then transferred to the printing media. The wood itself was fashioned from boxwood, lemonwood, or cherry. It ~~also~~ must also prevail from the trunk or a large branch.

The blocks eventually would be constructed at the height and size needed to fit in the letterpress. When the older illustration types fell out of favor, these new blocks would fit into

Formatted: Font: Italic

Formatted: Font: Italic

Formatted: Font: Italic

Formatted: Font: Italic

the press and continue to be used for repeated printings like almanacs. Woodcut is different ~~than from~~ the wood engraving because it uses wood cut along the grain contrary to the end grain. All of these methods are relief printing, however, and woodblock printing is the accepted technique explored in this article.

Black and white woodblock printing reigned supreme until the fourteenth century in China. Although color appears on silk, we do not see color on paper for more than a millennium. Using three colors takes almost another three centuries after that. Interestingly, Germans invented color woodblock printing on paper in 1508 and named it *chiaroscuro*, meaning light and dark. Woodblock printing influenced the development of different book cultures, whereas, in some countries, it was applied only to ~~only~~ prestigious works, and in other countries it was used for the vernacular or erotica.

Woodblock printing has persevered since the Tang Dynasty. The Chinese printed stationary, entertainment, ~~new New year Year~~ prints, rituals, and folklore prints [9]. The technique gained popularity during the Song Dynasty. It spread to government documents like land transfers, business accounting receipts and wedding dates. Unfortunately, the decline was attributed to the destruction of many workshops during the civil wars. Nonetheless, woodblock printing has survived in art form. ~~As Even though~~ modern technology has overcome this type of time-consuming method, ~~yet~~ newer advanced technology is now contributing to new forms of woodblock printing that involve 3D printing [10]. In the 3D construction, four basic wood tissues are recreated: catheter, axial parenchyma, wood fiber and wood ray. Technological advances and artistic popularity are keeping woodblock alive after more than 1400 years.

The following research project describes the development of an art paper product for Large Wood Relieve Block (LWRB) printing. In the past, artists at Syracuse University (SU) used muslin fabric in bleached and unbleached form as the printing medium for large relieve wood block printing images of up to 4 ft (1200mm) by 8 ft (2400 mm) in size for the annual outdoor steam roller printing event. Previous attempts to use paper were not successful due to paper breakage during the printing. ~~Because Since~~ the steam roller event takes place outside, the artists specified that the paper must be heavy enough to withstand environmental factors such as wind and moisture. In addition, the paper should have an off-white color, and the furnish must be acid free to avoid yellowing of the paper, as it ages, and should not contain sizing for better oil-based ink penetration. Based on these requirements given by the artists, the paper development was initiated.

2. MATERIALS AND METHODS

The ~~following~~ materials and methods that are presented in the sub-sections below were used for the Large Wood Relief Block (LWRB) art paper. ~~art paper~~

2.1. Materials Used

For the development of the LWRB art paper, Northern Bleached Hardwood Kraft (NBHK) pulp from, Northern Bleached Softwood Kraft (NBSK) pulp, Cotton pulp for a soft appearance and Bleached Eucalyptus Kraft (BEK) pulp as a second hardwood source were selected as fiber material.

Precipitated Calcium Carbonate (PCC) Albacar® HO in dry powder form from specialties Minerals Inc. (SMI) was selected as possible filler material to increase optical properties to save of fiber materials [11].

Dyes used for the art grade were an anionic blue dye, ~~and~~ cationic red and yellow dye from the Kemira Lavacell™ family.

Retention aid used for the art grade was a cationic acrylamide copolymer (cPAM) from Kemira FennoPol™ polyacrylamide flocculant family.

Formatted: Font: Italic

2.2. Testing Methods

For this research project, the following testing methods of the Technical Association of the Pulp and Paper Industry (TAPPI) were used are presented below:

Beating of pulp (Valley beater method) was used in accordance to T 200 sp-06 "Laboratory beating of pulp (Valley beater method)" [12].

Handsheets were prepared according to TAPPI T205 sp-12, "Forming handsheets for physical tests of pulp" [13]. Physical testing of handsheets was performed in accordance with T 220 sp-06, "Physical testing of pulp handsheets" [14]. Freeness of pulp was measured as Canadian Standard Freeness (CSF) according to T 227 om-09 "Freeness of pulp (Canadian standard method)" [15]. Consistency of the pulp suspensions was measured with TAPPI T240 om-07 "Consistency (concentration) of pulp suspensions" [16].

Conditioning of the paper samples was done according to T 402 sp-08, "Standard conditioning and testing atmospheres for paper, board, pulp handsheets, and related products" [17]. Burst Strength was measured in accordance with T 403 om-02 "Bursting strength of paper" [18]. Basis weight was measured with T 410 om-08, "Grammage of Paper and Paperboard (weight per unit area)" [19]. Thickness of the paper was measured with TAPPI T 411 om-10, "Thickness (caliper) of paper, paperboard, and combined board" [20].

Moisture content of pulp was determined by T412 om-06 "Moisture in pulp, paper and paperboard" [21]. Bending resistance was measured according to TAPPI T 489 om-08 "Bending resistance (stiffness) of paper and paperboard (Taber-type tester in basic configuration)" [22]. Surface roughness of the paper product was measured with TAPPI T 538 om-08. Roughness of Paper and Paperboard (Sheffield method) [23]. The air permeance of the paper product was measured with TAPPI T547 om-07 "Air permeance of paper and paperboard (Sheffield method)" [24].

Brightness was measured according to ISO 2469 "Paper, board and pulps - Measurement of diffuse radiance factor (diffuse reflectance factor)" [25].

Color was measured according to ISO 5631-2 "Paper and board - Determination of colour by diffuse reflectance - Part 2: Outdoor daylight conditions (D65/10 degrees)" [26].

2.3. Art Paper Handsheet Development Procedure

The handsheet development was done in a four-step process, according to pulp fibers needed and time requirement for making the handsheets. First, for a visual and preliminary print evaluation, of handsheets was done according to TAPPI method T200-sp-06. The produced TAPPI handsheets have a diameter of approximately 6.25 in (159 mm), which was not enough for a detailed printing evaluation. Therefore, handsheet making was switched in the second development process to a 12 inch (300 mm) square handsheet former shown in Fig. 1. The prepared fiber suspension was stored in the pulp storage tank and moved from the pulp storage to the handsheet former as needed. A paper machine wire fabric was used as the supporting forming wire. The produced wet handsheet was then couched on a dryer fabric, and then dried together with the dryer fabric a drying device, as shown in Fig.1.

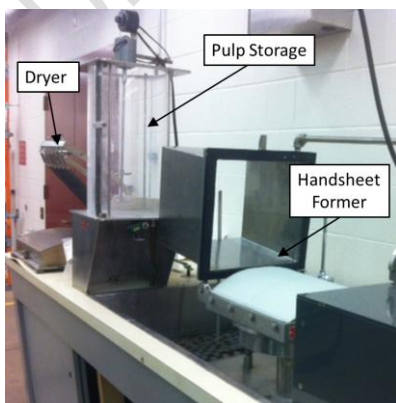

Fig. 1. 12" (300 mm) Handsheet forming [27].

In the third development process, the produced 12-inch square handsheets were then tested by artists with a small printing press for its suitability for wood relief block printing, as shown in Fig. 2 as follow:

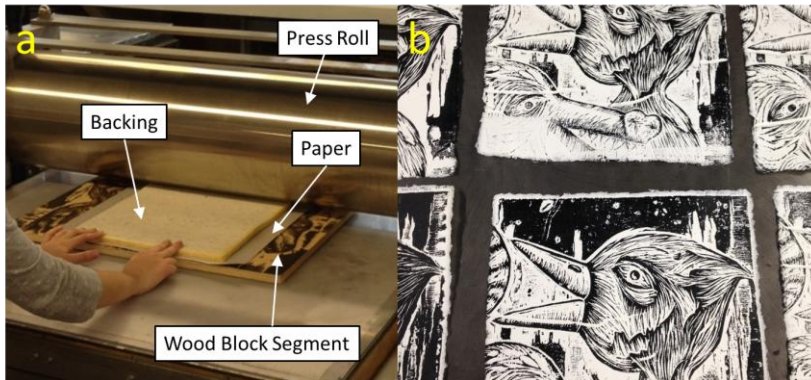

Fig. 2. Testing the art paper: a) printing process, b) printed test images [28].

Printing ink is applied to the cut wood relief block, followed by positioning the paper sample on the wood relief block. A backing, usually a felt like material, is put on top of the paper and the assembly, consisting of the wood relief block, paper and backing is moved through the printing press, as shown in Fig 2a, either under manual or automatic operation of the printing press. After printing, the quality of the images, shown in Fig. 2b, are evaluated by the artist.

The fourth development step included a beating evaluation, according to TAPPI method T200-sp06, of the final selected pulp composition, to provide better interfiber bonding during sheet forming.

After the final handsheet composition and the pulp fiber beating level was selected by repeating development process 1 to 3, handsheets were made in a fourth step using a MK Systems Inc. sheet former, as shown in Fig. 3. for the final visual and print evaluation by the



Fig. 3. MK Systems Inc. dynamic sheet former [29]

artist. The MK Systems Inc. sheet former allows to make a more precise 12-inch (300 mm) square handsheets, close to a quality level as a 12-inch (304 mm) pilot paper machine, but without applying the process steps of fiber orientation during sheet forming at the fourdrinier section, pressing, drying and clandering section.

2.4. Laboratory Fourdrinier Paper Machine Run

For upscaling the laboratory tested art paper into continuous production scale, a 12-inch (304 mm) wide Laboratory Fourdrinier Paper Machine (LFPM) located at the pilot plant of the Chemical Engineering Department at SUNY-ESF is used to produce a continuous art paper that can be cut into smaller sizes for print evaluation, as described in Section 2.4. The set-up of the LFPM system can be described as follows:

2.4.1. Stock Preparation System

The stock preparation of the LFPM, shown in Fig. 2, consists of a 5 hp (3.73 kW), 35 gal (132.5 l) low consistency pulper, a 3 hp (2.24 kW) transfer pump, a 10 hp (7.46 kW) low consistency conical Jordan refiner, and two storage chests with a usable volume of 240 gal. (908.5 l) each, and a propeller agitator with 1.5 hp (1.12 kW). The chests can be operated separately or together. Additives for papermaking can be added either in the pulper or the storage chests.

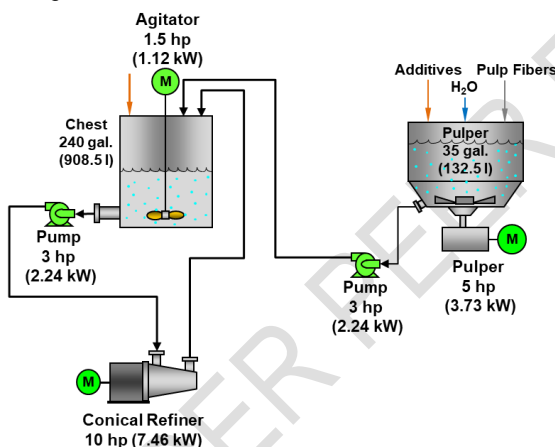

Fig. 4. Laboratory stock preparation system [30].

2.4.2. Wet End System

The wet end of the LFPM, shown in Fig. 5., consists of the two storage chests with a usable volume of 240 gal. (908.5 l) each, and a propeller agitator with 1.5 hp (1.12 kW). The 2 storage chests serve as the LFPM machine chest. Additives might be added at the machine chest as needed. The chests can be operated separately or together. An impeller transfer pump with 1.5 hp (1.12 kW) supplies the prepared fiber suspension to the stuff box. Additives might be added at the stuff box as needed. From the stuff box the fiber suspension is metered into the 10 gal. (37.4 l) mix chest, where additives might be added as needed. Part of the fiber suspension from the stuff box is recirculated to the machine chest. In the mix chest the fiber suspension is diluted with the white water from the LFPM white water trough. A possible overflow is transferred to the sewer. An impeller pump with 1 hp (0.75 kW) transfers the final prepared fiber suspension to the LFPM for papermaking.

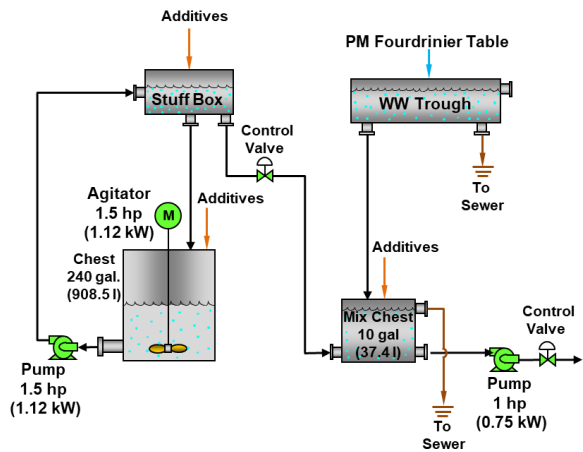

Fig. 5. Wet End of the 12" laboratory Fourdrinier paper machine [31].

2.4.3 12" Laboratory Fourdrinier Paper Machine

The LFPM shown in Fig. 6 was used to upscale the produced art paper from the handsheet study.

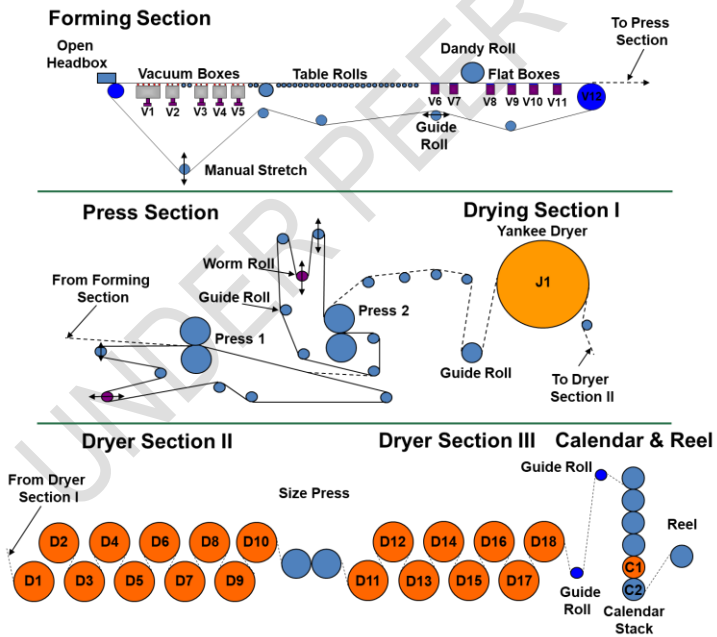

Fig. 6. Laboratory Fourdrinier paper machine [32].

The LFPM features a 70 inch (1778 mm) long Fourdrinier section, followed by a 2-nip press section. After the press section, there can be found a dryer section containing a Yankee

dryer (J1) and a 1st and 2nd dryer section with 10(D1-D10) and 8 (D12-D18) electric heated dryer drums. Each dryer drum can be heated to up to 343°C (650°F). Between the 1st and 2nd dryer section, a size press is located. A 6-roll vertical calendar stack, of which on roll (C2) can be heated, is located after the dryer section followed by the reel. The LFPM wet end has a total installed electrical power of 4 hp (3.0 kW), and the LFPM has a total installed power of 30 hp (22.5 kW). The LFPM can produce a finished paper product with a basis weight between 20 g/m² and 750 g/m² at a speed of up to 8.0 m/min.

2.5. 48-inch Small Commercial Fourdrinier Paper Machine

To produce the final art paper on a large scale, a 48-inch Small Commercial Fourdrinier Paper Machine (SCFPM) located at the pilot plant of the Chemical Engineering Department at SUNY-ESF is used to produce an 48-inch (1219.2 mm) wide continuous paper sheet that can be cut into all standard paper sizes. The results from the art paper runs at the LFPM are used to upscale the art paper product for commercial production of 700 lbs. of art paper. The set up of the commercial SCFPM run can be described as follows:

2.5.1. 48-Inch Small Commercial Fourdrinier Paper Machine Stock Preparation

The stock preparation of the SCFPM consists of a 50 hp (37.28 kW), 1800 gal (6800 l) low consistency pulper, a 15 hp (11.12 kW) transfer pump, a 150 hp (111.86 kW) low consistency conical Jones-Bertram beater, and a storage chests with a usable volume of 15000 gal. (56780 l). the storage chest is agitated with a propeller 20 hp (14.91 kW) propeller agitator. Additives for papermaking can be added either in the pulper, the Jones-Bertram beater or the storage chests.

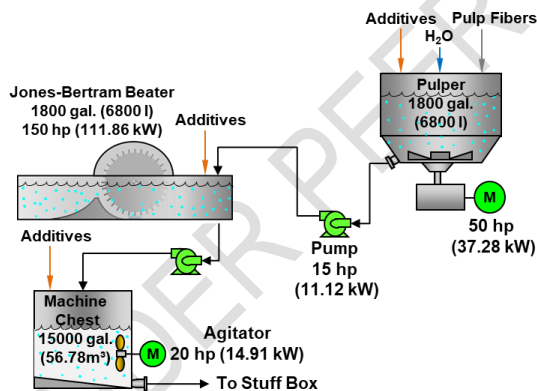

Fig. 7. 48-inch small commercial Fourdrinier paper machine stock preparation [33].

2.5.2. 48-Inch Small Commercial Fourdrinier Pilot Paper Machine Wet End System

The wet end of the SCFPM, as shown in Fig. 8, consists of a 6500 gal. (56.78 m³) machine chest with a 20hp (14.91 kW) agitation propeller. A 15 hp (11.12 kW) impeller pump transfers the stock to a Stuff box. A basis weight mixing valve regulates the pulp fiber flow to a 184 gal (743.3) mixing chest, where the pulp fibers are mixed and diluted with the white water from the paper machine, head box overflow, additives and pressure screen reject flow to a head box consistency of approximately 1%. The white water used for dilution consists of removed water from the table rolls, low vacuum and high vacuum which is pumped from the seal pit to with a 3 hp (2.25k kW) impeller pump to the white-water trough. From the mixing chest, the pulp fiber suspension is pumped with an impeller head box pump having 15 hp (11.12 kW) to a pressure

screen driven by a 30 hp (22.37 kW) electro motor. The head box screen supplies the paper machine headbox with the prepared pulp fiber suspension. The volumetric flow to the head box is controlled by a flow control valve. The pressure screen reject is sent back to the mixing chest.

The SCFPM vacuum system consists of 2 vacuum pumps with 40 hp (29.82 kW) and 20 hp (14.91 kW), having a common header. The vacuum systems provide vacuum for the FCFPM high vacuum boxes, the couch roll and the press section vacuum boxes.

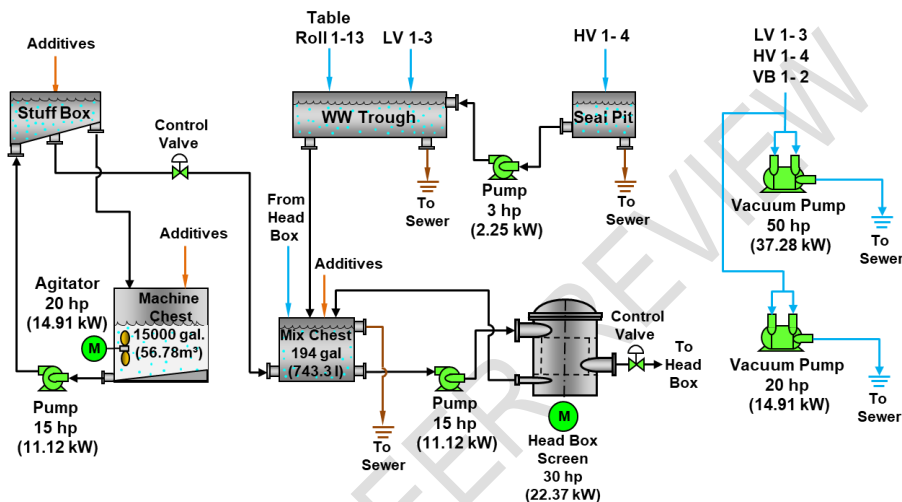

Fig. 8. 48-inch small commercial Fourdrinier paper machine wet end system [34].

2.5.3. 48-Inch Small Commercial Fourdrinier Paper Machine

The SCFPM shown in Fig. 9. has a 280" (7112.0 mm) long Fourdrinier Forming Section (FFS) with a 48" (1219 mm) headbox slice opening and forming board. The Breast roll of the FFS is attached to a shake having 3 hp (2.23 kW) and a stroke of 0 to 7/8-inch (0 to 22.23 mm) adjustable to a frequency between 2.5 to 10 Hz for improving sheet formation and fiber orientation on the forming wire. In addition, the FFS contains 13 table rolls with a diameter of 3.5" (88.9 mm), 3 foil boxes, 4 high vacuum sections, a 12" (304.8 mm) dandy roll, and a 14" (355.6 mm) diameter vacuum couch roll, including a couch pulper with a 1 hp (0.75kW) electro motor. The couch roll is driven by a 20 hp (14.91 kW) electro motor.

The paper is transferred from the FFS to the press section which contains a 1st and a 2nd press with a maximum loading of 500 pli (87.6 kN per m) press loading. The 1st press has a press roll with 13" (330.2 mm) diameter and a 14" (355.6 mm) grooved roll. The 2nd press has a press roll with 14" (355.6 mm) diameter and a 14" (355.6 mm) smooth roll. Each press section is driven by a 10hp (7.46 kW) electro motor.

The pressed paper is fed into the dryer section featuring a 1st dryer section with 13 dryer cylinders. The first dryer cylinder has a diameter of 24" (609.6 mm). The remaining dryer cylinders have a diameter of 48" (1219.2 mm). The dryer section is driven by interlocking gear drive powered by a 30 hp (22.37 kW) electromotor. The 2nd dryer section contains five 48" (1219.2 mm) diameter drying cylinders driven by an interlocking gear drive powered by a 20 hp (14.91 kW) electromotor. All dryers in the drying section are supplied with steam at a pressure of up to 15 psi (103.42 kPa).

Afterwards, the drying section the paper is transferred thorough a 7-roll vertical calendar stack. The first roll (top roll) has a diameter of 14" and a weight of 4000 lbs (kg). The 3rd, 4th, and 5th roll have a diameter of 10" (mm) and a weight of 2500 lbs (kg). The 5th and 6th roll have a diameter of 13" (mm) and a weight of 4000 lbs (kg). The 7th roll is the supporting and drive roll with a diameter of 20" (mm), and is driven by a 40 hp (29.83 kW) electro motor.

The finished paper is rolled up at a two-roll reel section into paper rolls of up to approximately 750 lbs. (340 kg) each. The reel is powered by a 20 hp (14.91 kW) electro motor. The SCFPM can produce a finished paper product with a basis weight between 20 g/m² and 750 g/m² at a width of up to 44" (1118 mm) at a maximum speed of up to 350 ft/min (106.7 m/min).

The total installed electrical power of the wet end system, the SCFMP, and SCFPM vacuum system is 83 hp (61.89 kW), 151 hp (112.60 kW), 100 hp (74.57 kW) respectively, with a total installed electrical power of 234 hp (174.49 kW) for the complete paper production system.

The steam for the FCFPM dryer section is supplied as low-pressure steam at 15 psi (103.42 kPa).

UNDER PEER REVIEW

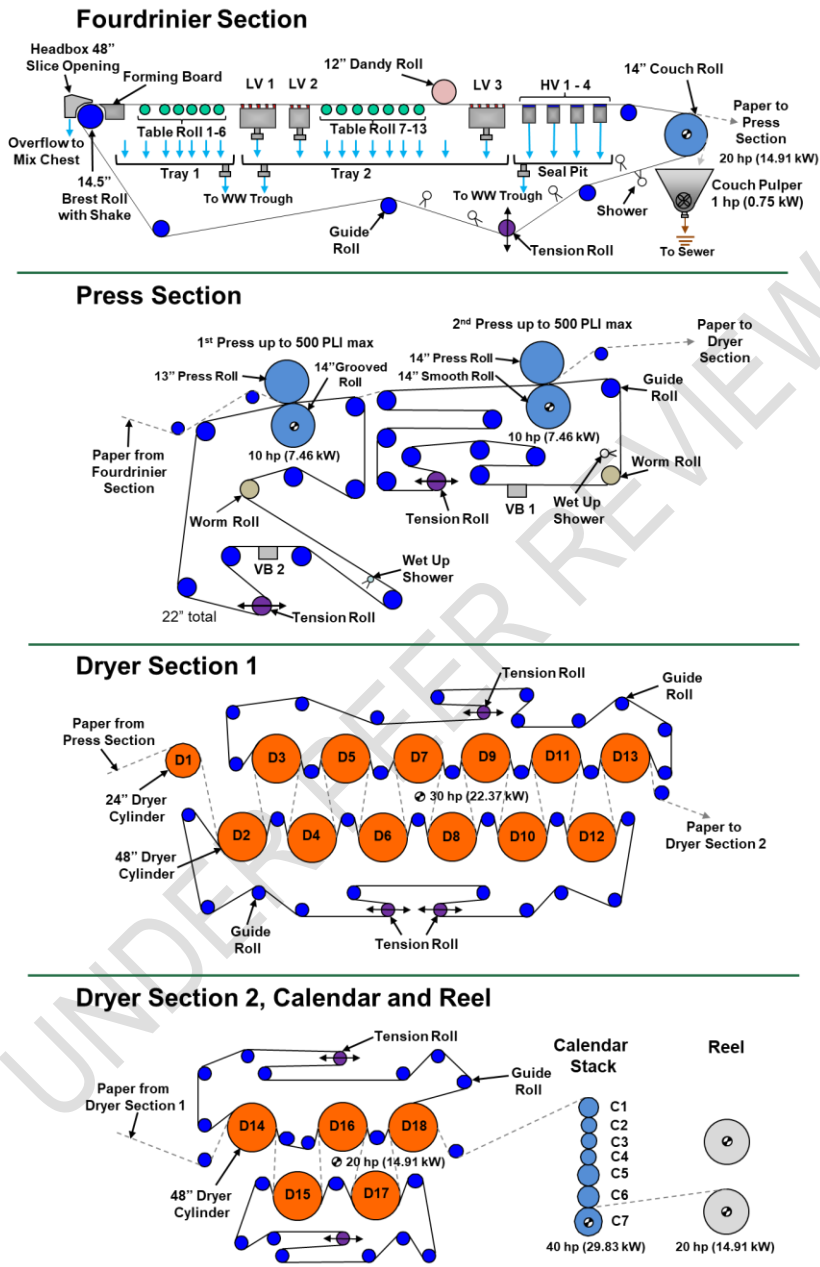

Fig. 9. 48-inch small commercial Fourdrinier paper machine [35].

3. RESULTS AND DISCUSSION

All tests for this research and development project were performed in accordance to the [TAPPI and ISO methods referenced](#) in Section 2.3. [referenced TAPPI and ISO methods](#). All results stayed in the precision statements for the referenced TAPPI and ISO methods.

3.1. Handsheet Development

The first set of TAPPI handsheets created for the (LWRB) art paper contained the following fiber mixtures: a) 75% NBSK, 20% NBHK, and 5% Cotton, b) 15% NBSK 75% NBHK, 10% [Cotton-cotton](#) to give the paper a soft feel, c) 75% NBSK 25% NBHK, and d) 75% NBSK and 25% EBK pulp fibers. The artist's evaluation of the handsheets included mimicking the steam roller event using a printing press and [to-seeing](#) how well the ink appeared after being applied on the

paper. This evaluation eliminated handsheets a) and b) containing cotton fibers, because the NBHK containing handsheets gave us a smoother sheet and, due to the smaller hardwood fibers, a better print gloss. In addition, hardwood pulp is approximately 20% less expensive than softwood pulp, and over 50% less expensive than the cotton pulp. It was decided, [to](#) due to the advantages of the hardwood fibers, to increase the hardwood content in the handsheets.

The second set of four fiber mixtures contained: a) 70% NBHK 30% NBSK, b) 70% NBHK 30% NBSK 10% Filler (PCC), c) 70% BEK 30% NBSK, d) 70% BEK 30% NBSK and 10% Filler (PCC). The 10% PCC was added based on OD fiber weight.

The evaluation of the artists found that the PCC containing handsheets and BEK pulp did not meet the artists' expectations in regard to printability and durability of the paper product. The final fiber content for the art paper was decided to contain 70% NBHK and 30% NBSK pulp fibers.

The next step in evaluating the final fiber composition was to investigate which beating level is needed to best meet the artists' specifications. The pulp fiber mixture was beaten using a Valley Beater for 5, 10, 15, 20, 30, and 45 minutes. For each beating level, enough sample pulp was taken to produce handsheets. From all the samples tested, the artist preferred the print quality of the sample that was beaten for 15 minutes, which reflects a freeness level of 480 ml, which is used for the 12-inch laboratory and 48-inch small scale Fourdrinier paper machine.

An additional evaluation was conducted using the 12-inch paper machines calendar section by applying pressure levels of 12, 16, 20, 26 and 30 psi in two nips of the calendar.

[The](#) artist preferred the print using 26psi in 2 nips of the small paper machine calendar. This equated to 219 PLI, and the top two nips of the stack on the large paper machine.

In between tests, the respective develop art test paper was evaluated using a printing process as described in Subsection 2.4.

The artists' off-white egg-shell colour preference was achieved during the laboratory development by adding 0.8 lbs/short ton (400.0 g/t) of cationic yellow dye, 0.16 lbs/short ton (80.0 g/t) of cationic red dye, 0.04 lbs/short ton (20.0 g/t) of anionic blue dye to the 70% NBHK, and 30% NBSK pulp fiber mixture.

3.2. Art Paper Properties based on Laboratory Development.

Based on the laboratory handsheet development, the selected final fiber mixture (70% NBHK and 30% NBSK pulp) will need to be beaten to a 480 ml level prior to papermaking. No additives will be added to the pulp suspension during the papermaking process. [The](#) artists' request [is](#) for the paper to be able to withstand the wind, considering [that](#) the paper will be used in outdoor events, grammage, thickness and bending stiffness, [which was was](#) tested according to TAPPI method T 410, T 411, and T 489 and property target of 150 g/m², 230 µm, and 50 mN in machine direction (MD) and 30 mN in machine Cross Direction (CD) respectively. Since the paper is being put on a wooden block and then having ink rolled on to

it via a printing press or steam roller burst, this is an important property to test for. The target for the burst index, according to TAPPI Test method T 403, was set to 1.23 kPa/m². It was decided by the artist that roughness, according to TAPPI test method T 538, as a key surface property requirement for printing was another key property. The target value was set to be 2097 ml/min. Porosity, according to TAPPI test method T 538, of the art paper allows the ink to set into the paper and the set target was 1523 ml/min. The color target for the off-white color (eggshell-color) was set at ISO brightness level according to the ISO 2470 at 69.83% and a color value according to the ISO 5631-2 method for L, a, b, at 92.19, 0.62, and 9.83, respectively.

3.3. 12-inch Laboratory Fourdrinier Paper Machine Run

The LFPM run is using NBHK and NBSK pulp fibers and is designed for a maximum of approximately 2.5 hours, producing a sheet at 150g/m². This will leave enough time to start-up the LFPM, make needed adjustments to meet paper properties, and produce enough pulp for the printing evaluation by the artist.

First, 24 lbs (10.9 kg) OD of the 70% NBHK and 30% NBSK virgin pulp fiber mixture was pulped in two batches of 28.8 gal (109.0 l) each at a consistency of 5% using the 35 gal (132.5 l) low consistency laboratory pulper of the LFPM stock preparation system. After the NBHK and NBSK pulp mixture was disintegrated, the 5% pulp fiber slurry was transferred into the 240-gal (908.5 l) storage chest. The 57.6-gal. (218.0 l) NBHK and NBSK pulp fiber slurry was then diluted to a consistency of 3% by adding 38.4 gal. (145.2 l) water for refining. Second, the 96.1 gal (363.2 l) NBHK and NBSK pulp slurry was then refined to a CSF value of 480 ml from an initial CSF of 620 ml with a Jordan conical refiner for 10 minutes under a 1.5 Amp net load. The CSF value was measured with TAPPI test method T 227 om-09. After refining the EC fiber slurry was diluted to a machine chest consistency of 1.5% by adding 96.1 gal (363.2 l) of water, which resulted in 192.2 gal (726.4 l) of the NBHK and NBSK pulp fiber mixture at 1.5% consistency, available for the art paper production.

Third, to the 1.5% NBHK and NBSK pulp fiber mixture 0.182g anionic blue dye, ~~and~~ 0.724g cationic red, and 3.63g yellow dye were added to the prepared batch and mixed in with the machine chest agitator.

Fourth, the FPM paper machine run was conducted containing the following:

- a) The LFPM was operated at a speed of 1.6 m/min for all production runs. Vacuum levels for the fourdrinier table were set at 0 for the 1st, 27579 Pa for the second vacuum section, 0 for the 3rd to 6th, 13789 Pa for the 7th, 27579 Pa for the 8th, 48263 Pa for the 9th, and 0 for the 10th vacuum section. The fiber flow to the headbox at a consistency of 1% was set at 7.29 l/min initially and increased up to 8.95 l/min to achieve the desired basis weight of the art paper product.
- b) The 1st and 2nd press was operated at 217728 Pa for all adjustment of the art grade. The heat of the Yankee-Dryer (J1) in dryer section 1 was kept at 50°C (122°F). The heat for the dryers in dryer section 2 is kept at 148.9°C (300°F) for the 1st to the 4th dryer (D1-D4), 143°C (290°F) for the 5th to 10th (D5-D10) dryer. The heat in dryer section 3 was kept at 148.9°C (300°F) for the 11th to the 16th (D11-D16) dryer, and 50°C (122°F) for the 17th and 18th (D17-D18) dryer. The calendar section for all furnishes is operated without pressure for all calendar rolls and without heat for calendar rolls C1 and C2.

3.4. 48-inch Small Commercial Fourdrinier Paper Machine Run

The SCFPM art paper run using NBHK and NBSK pulp fibers was designed for a maximum of approximately 3.0 hours, producing a sheet at 150g/m². This will leave enough time to start-up the SCFPM, make needed adjustments to meet paper properties, and produce about 770 lbs (350 kg) art paper.

First, 1600 lbs (726 kg) OD of the 70% NBHK and 30% NBSK virgin pulp sheets were pulped in two batches of 1800 gal (6800 l), each at a consistency of approximately 5% using

Formatted: Numbered + Level: 1 +
Numbering Style: a, b, c, ... + Start at: 1 +
Alignment: Left + Aligned at: 0.25" + Indent
at: 0.5"

the 1800 gal (6800 l) low consistency pulper of the SCFPM stock preparation system. Each batch from the low consistency pulper was split in half (900 gal) and transferred to Jones Bertram Beater and diluted to a consistency of 2.5% by adding 900-gal (3400 l) water.

Second, the 1800-gal (6800 l) NBHK and NBSK pulp slurry was then refined to a CSF value of 480 ml from an initial CSF of 620 ml with the Jones-Bertram Beater for 21 minutes per batch and a 170 Amp total load. The no load was 80 Amps, which translates into 50 kW net refining energy. The CSF value was measured with TAPPI test method T 227 om-09. After refining, the EC fiber slurry was transferred into the 15,000-gal (56.78 m³) machine chest of the SCFPM.

Third, to the 2.5% refined NBHK and NBSK pulp fiber mixture 21.8 g anionic blue dye, and 87.16 g cationic red, and 435.4 g yellow dye were added to the prepared batch and mixed in with the machine chest agitator.

Fourth, the FPM paper machine run was conducted containing the following:

The FPM was operated for the art grade production at a speed of 20.4 m/min, with a headbox slice opening of 19 mm, and a shake frequency of 81 per minute. The vacuum levels for the fourdrinier table were set for the three low vacuum boxes 1 to 3 at 1742 Pa, 2240 Pa, and 2737 PA respectively. The four high vacuum boxes 1 to 4, the vacuum was set at 747 Pa, 995 Pa, 995 Pa, and 871 Pa respectively. The couch roll vacuum was set at 1555 Pa. The fiber suspension flow to the headbox was adjusted to 1% in the mixing chest by recirculating the white water from the white-water through with a fiber suspension flow of 98 gal/min (373 l/min) (see Figure 8), in order to achieve the targeted basis weight of 150 g/m² of the art paper.

The 12-inch LFPM has a retention above 80%, therefore no retention aid needed to be added. To increase the retention of the SCFPM, a retention aid in form of a cationic acrylamide copolymer (cPAM) was added at the fan pump at 0.75 lbs/short ton (0.375 kg/metric ton) to increase retention on the SCFPM. The produced art paper had a solids content of 19.2% after the fourdrinier couch roll before entering the 1st Press.

The 1st and 2nd press ~~was~~ were operated at 14 psi and 18 psi pressure respectively, which correlates to a line pressure of 72.5 N/mm for the 1st and 108 N/mm for the 2nd press. The archived solids content of the fiber mat for the art paper was 31.43% after the 1st Press, and 41.59% after the 2nd press. The wet art paper fiber mat is then fed into the 1st dryer section with a solids content of 41.59% from the 2nd Dryer section.

The two dryer sections of the SCFPM, as shown in Figure 9, contain eighteen dryer cans D1 to D18. For the art paper production run dryer can D1 to D3 were operated at a temperature of 218°F (103.3°C), 200°F (93.3°C), and 220°F (104.4°C) respectively. Dryer can D4 to D7 were not heated, but temperatures measured were 110°F (43.3°C), 135°F (57.2°C), 105°F (40.5°C), and 145°F (62.7°C) respectively. Dryer cans D8 to D10 were heated to temperatures of 163°F (72.8°C), 215°F (101.7°C), and 212°F (100.0°C) respectively. Dryer cans D11 to D13 were not heated, but temperatures reached 153°F (67.2°C), 110°F (43.3°C), and 118°F (47.8°C) respectively. Dryer cans D14 to D16 operated under heat at temperatures of 203°F (95.0°C), 217°F (102.8°C), and 205°F (96.1°C) respectively. Dryer cans D17 and D18 operated without heat, but had a temperature of 120°F (48.9°C) and 97°F (36.1°C). The produced art paper had a solids content of 95± 2%.

The calendar section was operated without pressure for all production runs.

The produced art paper was reeled to rolls with a maximum weight of approximately 500 lbs (227 kg) with a solids content of 95± 2%.

The paper rolls were converted into smaller rolls with a length of approximately 100 ft (30m) and paper sheets with a size of 44-inch x 36-inch (1118 mm x 914 mm) for further processing and printing of the art paper.

3.5. Paper Testing Results

Paper testing results of the art paper produced with the 12-inch PM and 48-inch PM are shown in Fig. 10 t-o17, including target values based on the handsheet development.

Fig. 10. shows the art paper basis weight and caliper ~~was~~ were targeted at 150 g and 240 μm respectively. The 12-inch PM and 48-inch PM run achieved a basis weight of 143 g and 171 g and a caliper of 270 μm and 260 μm respectively. The basis weight for the 12-inch run was 4.7% lower, and for the 48-inch run 14.0% higher than the set target value. The thickness of the art paper was for the 12-inch PM and 48-inch PM run 12.5% and 8.3% higher respectively.

Fig. 10. Paper machine run basis weight and calliper

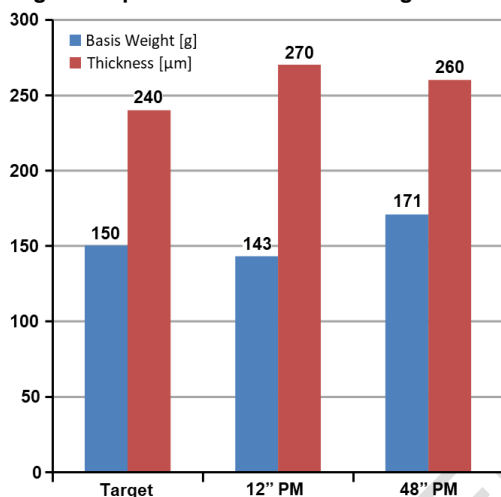

Fig. 11. shows the art paper burst index. The target from the paper development was set at 1.23 $\text{kPa}\cdot\text{m}^2/\text{g}$. The art paper produced with the 12-inch PM and 48-inch PM run achieved a burst index of 1.14 $\text{kPa}\cdot\text{m}^2/\text{g}$ and 2.24 $\text{kPa}\cdot\text{m}^2/\text{g}$ respectively. The burst index of the art paper was for the 12-inch PM 7.3% lower, and for the 48-inch PM run 82.1% higher.

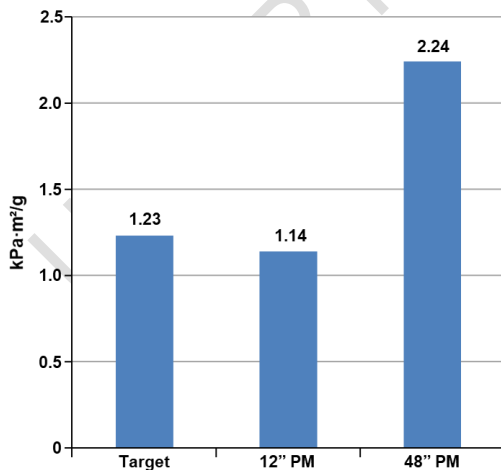

Fig. 11. Paper machine run burst index

Fig. 12. shows the produced art paper bending stiffness in MD and CD direction, including the targeted bending stiffness of 50 mN and 30 mN, respectively, based on the laboratory development. The 12-inch PM and 48-inch PM run achieved a bending stiffness of 55 mN and 34 mN for the MD and CD direction and 157mN and 70 mN for the MD and CD respectively. For the 12-inch PM run the bending stiffness was 10.0% for the MD and 13.3% for the CD higher than the set target value. The bending stiffness for the 48-inch PM run was 314.0% for the MD and 233.3% for the CD higher.

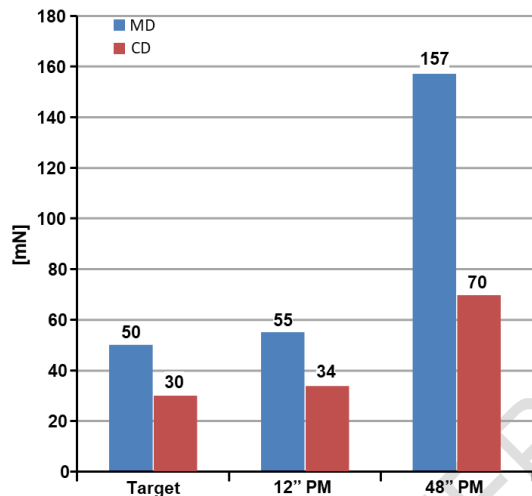

Fig. 12 Paper machine run bending stiffness

Fig. 13. shows the art paper porosity value with the set target at 1522 ml/min. The 12-inch PM and 48-inch PM run achieved a porosity of 1170 ml/min and 1668 ml/min respectively. The porosity for the 12-inch PM run was 23.1% lower and for the 48-inch PM run 9.6% higher than the set target value.

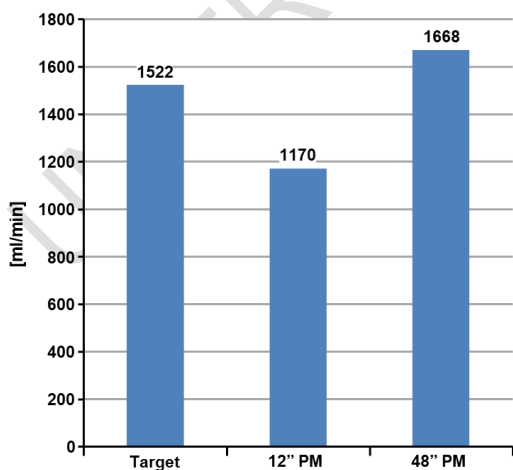

Fig. 13. Paper machine porosity

Fig. 14. shows the produced art paper roughness for the top and bottom side (wire side) of the paper, including the targeted roughness of 2097 ml/min for both paper sides based on the laboratory development. The 12-inch PM and 48-inch PM run achieved a roughness of 2269 ml/min and 2035 ml/min for the top side and 2179 ml/min and 2326 ml/min for the bottom side respectively. For the 12-inch PM run the roughness was 8.2% for the top side and 3.9% for the bottom side higher than the set target value. The roughness for the 48-inch PM run was 2.9% for top side lower and 10.9% for the bottom side higher than the set target value.

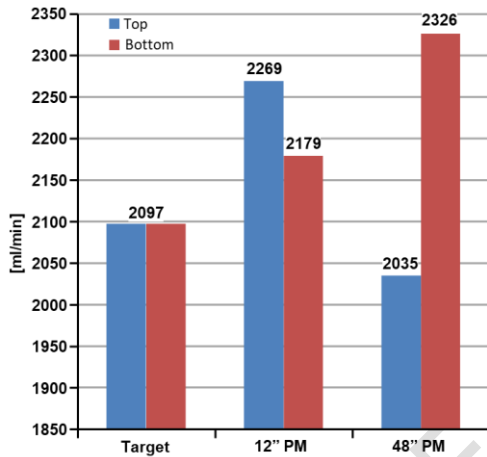

Fig. 14. Paper machine run roughness

Fig. 15. shows the art paper brightness value with the set target at 68.9%. The 12-inch PM and 48-inch PM run achieved a brightness value of 67.8% and 63.2% respectively. The brightness for the 12-inch PM run was 2.8% lower and for the 48-inch PM run 9.5% lower than the set target value.

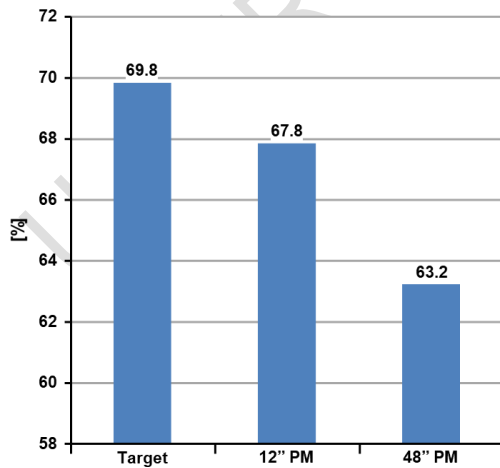

Fig. 15. Paper machine run brightness

Fig. 16. shows the L, a, and b color value of the produced art paper, including the targeted color value of 92.2% for the L-value, 0.6 for the a-value, and 9.8 for the b-value based on the laboratory development. The 12-inch PM run achieved a L, a, b color value of 95.2%, 1.0, 12.0 respectively. The 48-inch PM run achieved a L, a, b color value of 90.8%, 1.1, 12.6 respectively. For the 12-inch PM run the L, a, and b color value was 0.3%, 66.6% and 22.4% higher than the targeted value. The 48-inch PM run L color value was 1.5% lower, the a color values ~~was~~ were 83.3% higher and the b color value was 9.8% higher than the set target value.

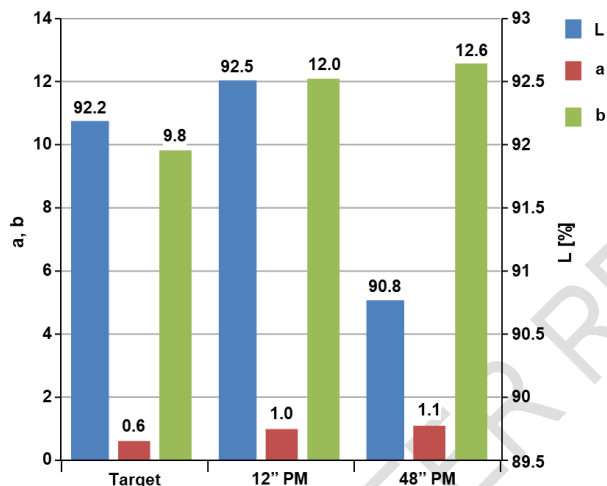

Fig. 16. Paper machine run colour

4. CONCLUSION

The presented research project describes the development of an art paper product applicable for large wood relieve block printing from laboratory scale to large semi commercial production on a 48-inch (1219 mm) paper machine. The final art paper will be used for small and large wood relief block printing for images up to 4 ft (1200mm) by 8 ft (2400 mm) in size at outdoor steam roller printing events or smaller indoor printing press applications.

The improvement of the paper properties from laboratory development, small laboratory paper machine and semi commercial paper machine run for the production of the final art paper showed an improvement throughout the process development for the optical and mechanical paper properties and exceeded the set values set by the artist using the art paper.

The produced art paper with a basis weight of 260 g/m² and a thickness of 171 µm is produced from a mixture of 70% northern bleached hardwood Kraft pulp and 30% northern bleached softwood Kraft pulp.

The ISO brightness of the art paper off-white (egg-shell) colour was at 63.2% and the ISO color value for L, a, b. at 90.8, 1.1, and 12.6 respectively.

The art papers surface roughness and porosity as a parameter for ink attachment and penetration is, for the top side, 2179 ml/min, and ~~bottom side (wire side)~~ bottom side (wire side) 2326 ml/min for the bottom side (wire side), whereas porosity was measured at 1668 ml/min.

| Since The art paper is being used for wooden block printing and ink is rolled on to it via a printing press or steam roller, bending stiffness and burst are important mechanical paper property.

| Bending stiffness in machine direction and cross machine direction were measured at 157mN and 70 mN respectively. Burst strength was measured at 2.24 kPA·m²/g respectively.

| The produced art paper was and is used in local and US wide steam roller print events, small and large wood relief printing applications, as well as water colour painting applications.

COMPETING INTERESTS DISCLAIMER:

Authors have declared that no competing interests exist. The products used for this research are commonly and predominantly use products in our area of research and country. There is absolutely no conflict of interest between the authors and producers of the products because we do not intend to use these products as an avenue for any litigation but for the advancement of knowledge. Also, the research was not funded by the producing company rather it was funded by personal efforts of the authors.

6. REFERENCES

1. Pan, Jixing. On the origin of printing in the light of new archaeological discoveries. *Chinese Science Bulletin*, June 1997, Volume 42, Issue 12, pp 976–981
2. Salter, Rebecca. (2001). Japanese Woodblock Printing. Bloomsbury Publishing, London. 128 p.
3. Buell Lewis, Albert. (1924). Block Prints for Textiles from India. Field Museum of Natural History, Anthropology, Design Series No. 1. Chicago.
4. Embassy of Japan in Pakistan. Japanese Woodblock Printing Workshop. Islamabad. May 23, 2014. Retrieved from pk.emb-japan.go.jp
5. Bulliet, Richard W. Medieval *Tarsh*: A Forgotten Chapter in the History of Printing. *Journal of the American Oriental Society* 107:3 (1987), pp.427-438.
6. Cummins, Julie. Dead Wood? The Forgotten Art of Woodcut Illustrations. *Children and Libraries*. Spring 2015, pp. 29-31
7. The way it worked: Woodblock printing. *Printing World*, 5 January 2006, p.23
8. McLaren, Anne E. From Folk Opera to the Printed Book in Early Twentieth-Century China. *The International Journal of the Book*. Volume 15, Issue 1, 2017, pp. 29-38
9. The Hong Kong Heritage Museum. The Art of Chinese Traditional Woodblock Printing. 1995. Retrieved from heritagemuseum.gov.hk
10. Zhuokai Qin, Jiasheng Zhang, Yutian Yang, Jianju Luo and Wei Gao, Constructing 3D Model of Hardwood Structure. *Key Engineering Materials*, 1662-9795, Vol. 719, pp 9-13. 2017 Trans Tech Publications, Switzerland
11. Doelle K, Amaya JJ, Application of calcium carbonate for uncoated digital printing paper from 100% eucalyptus pulp. *TAPPI Journal*. 2012;11(1):41-49.
12. TAPPI T 200 sp-06 Laboratory beating of pulp (Valley beater method)
13. TAPPI T 205 sp-12. Forming handsheets for physical tests of pulp.
14. TAPPI T 220 sp10. Physical testing of pulp handsheets.
15. TAPPI T 227 om-09. Freeness of pulp (Canadian standard method).
16. TAPPI T 240 om-07 "Consistency (concentration) of pulp suspensions
17. TAPPI T 402 sp-13. Standard conditioning and testing atmospheres for paper, board, pulp handsheets.

18. TAPPI T 403 om-02, "Bursting Strength of Paper".
19. TAPPI T 410 om-08. Grammage of Paper and Paperboard (weight per unit area).
20. TAPPI T 411 om-10. Thickness (caliper) of paper, paperboard, and combined board.
21. TAPPI T 412 om-06. Moisture in pulp, paper and paperboard.
22. TAPPI T 489 om-08 "Bending resistance (stiffness) of paper and paperboard (Taber-type tester in basic configuration)"
23. TAPPI T 538 om-08. Roughness of Paper and Paperboard (Sheffield method).
24. TAPPI T 547 om-07. Air permeance of paper and paperboard (Sheffield method)
25. ISO 2469 Brightness: "Paper, board and pulps - Measurement of diffuse radiance factor (diffuse reflectance factor)"
26. ISO 5631-2 Colour: "Paper and board — Determination of colour by diffuse reflectance — Part 2: Outdoor daylight conditions (D65/10 degrees)"
27. Dölle K., 12" (300 mm) Handsheet forming. pdf-file.
28. Dölle K., Testing the art paper: a) printing process, b) printed test images. pdf-file.
29. Dölle K., MK Systems Inc. dynamic sheet former. pdf-file.
30. Dölle K., Laboratory stock preparation. pdf-file.
31. Dölle K., Wet End of 12" of the laboratory Fourdrinier paper machine. pdf-file.
32. Dölle K., Laboratory Fourdrinier paper M\machine. pdf-file.
33. Dölle K., 48-inch small commercial Fourdrinier paper machine stock preparation system. pdf-file.
34. Dölle K., 48-inch small commercial Fourdrinier pilot paper machine wet end system. pdf-file.
35. Dölle K., 48-inch small commercial Fourdrinier paper machine. pdf-file.