

# Original Research Article

## DEVELOPMENT OF WIRELESS TECHNIQUE TO REGULATE SEED DROPPING IN A SEEDER FOR INTERCROPPING

### 1. ABSTRACT

Although intercropping gives additional yield per unit area than sole cropping, yield may also decrease as the crops differ in their competitive abilities. To avoid competition and to accompany complimentary action between the base crop and inter crop in intercropping practise, proper crop ratio of two crops should be maintained. When sowing with available seeders crop ratio was not maintained because of the **un non**-availability of a seed hopper, handling two different varieties of seeds and the un controlled seed flow from the hopper to the seed tube when ground wheel is rotating. To look after this problem an experiment was conducted at DFMPE, AEC & RI, Tamil Nadu Agricultural University, Kumulur by fabricating a seed hopper consisting of two compartments and circular shaped outlet for two variety of seeds and developing an RF (radio frequency) wireless technology to control servo motor in order to restrict the seed drop from seed hopper to the seed tube even though ground wheel is in running condition. In this paper considering a seven-row seeder, the performance of a micro controller coded with appropriate programme in embedded C language which can regulate seven servo motors each at seven seed hoppers, functioning of RF transmitter sketch, functioning of RF receiver sketch, header issue & its solution, angle conversion of servo shaft and power consumption was observed and discussed. Total power required for operating RF electronic setup containing seven servomotors was recorded as 5 V 12 A. Shaft rotation of 0° to 165° was achieved in each servo.

**Key words:** *Arduino Mega 2560, Servo motor, RF transmitter, RF receiver, Inter cropping*

### 2. INTRODUCTION

Intercropping is a multiple cropping practice involving cultivation of two or more crops in proximity. The most common goal of intercropping is to produce a greater yield on a given piece of land by making use of resources or ecological processes that would otherwise not be utilized by a single crop (Willey, 1990). Intercropping is a time-honoured agricultural technique. While previously it was applied with no specific knowledge, present day farmers can reap good harvests with scientific background of intercropping benefits (Brooker et al.,

2015). Intercropping practices differ in the arrangement, sowing time and plant combinations. Regarding the time of seeding, plants are sown either at the same time or when other species are already flowering or ready for harvesting (Horwith, 1985).

Electronics control system plays a major role in the field of Agriculture. It provides higher level of flexibility required for small product cycles. It provides the possibility of remote controlling as well as centralized monitoring and control (Wang *et al.*, 2006). It has greater extend of machine utilization and serves effectively for high dimensional accuracy requirements with excellent performance characteristics (Zhang *et al.*, 2002). Higher life is expected by proper maintenance and timely diagnosis of the fault.

In commercially available seeders when ground wheel rotates the seeds which were in seed box will be picked up by the seed metering disc and directly fall into the seed tube (Karayel *et al.*, 2006). This was inappropriate when an intercropping practise (sowing two varieties of seeds) was done with available seeders. Required crop ratio was not maintained when seeds are continuously falling from seed hopper to seed tube. There is necessity to restrict the seed flow from seed hopper to seed tube in order to achieve intercropping with pre-determined crop ratio (Praharaj and Blaise, 2016). An experiment was done at DFMPE, AEC&RI, Tamil Nadu Agricultural University, Kumulur to restrict dropping of one variety of seed from seed hopper when other variety of seeds are dropping from seed hopper into the seed tube even though ground wheel was in running condition by using electronic control systems. A single seed hopper containing two compartments in which seeds of two different crops can be placed in each compartment and a common circular outlet section is provided in which each variety of seed falls from each semi-circular part of the circular outlet. In this paper two modules were implemented for proper seed handling mechanism in tractor drawn seeder. The power to these modules is provided by 12 volts 20 amperes tractor's battery. The first module was transmitter module in which RF transmitter, micro controller board and switches are provided. This module was placed at driver's seat to operate or control by tractor driver to restrict the required variety of seed from dropping into the seed tube by sending radio frequency signal. The second module was the receiver module which contains RF receiver, micro controller board, voltage regulator and servo motors. The receiver module receives the signal wirelessly from the transmitter module and then controls the drop of seeds from hopper into the seed tube with the help of a servo motor placed in between the seed hopper and seed tube. The servo motor shaft was fitted with a semi-circular valve for opening and closing the way path between the seed hopper and seed tube for controlling two varieties

of seeds. This set up thus improved the proper seed handling in the field and makes the intercrop farming as user-friendly.

### 3. MATERIALS AND METHODS

#### 3.1.1 seed hopper

A seed hopper is made up of material grade Fe 410 and 18 gauge i.e., 1.214mm thickness mild steel sheet consisting of two compartments for both base crop and inter crop with a single circular outlet. The seed metering assembly consists of a circular disc, driven shafts, semi-circular valve attached to the shaft of servo motor which was placed at the bottom of seed hopper near outlet to restrict the seed flow for required crop as shown in fig 1.

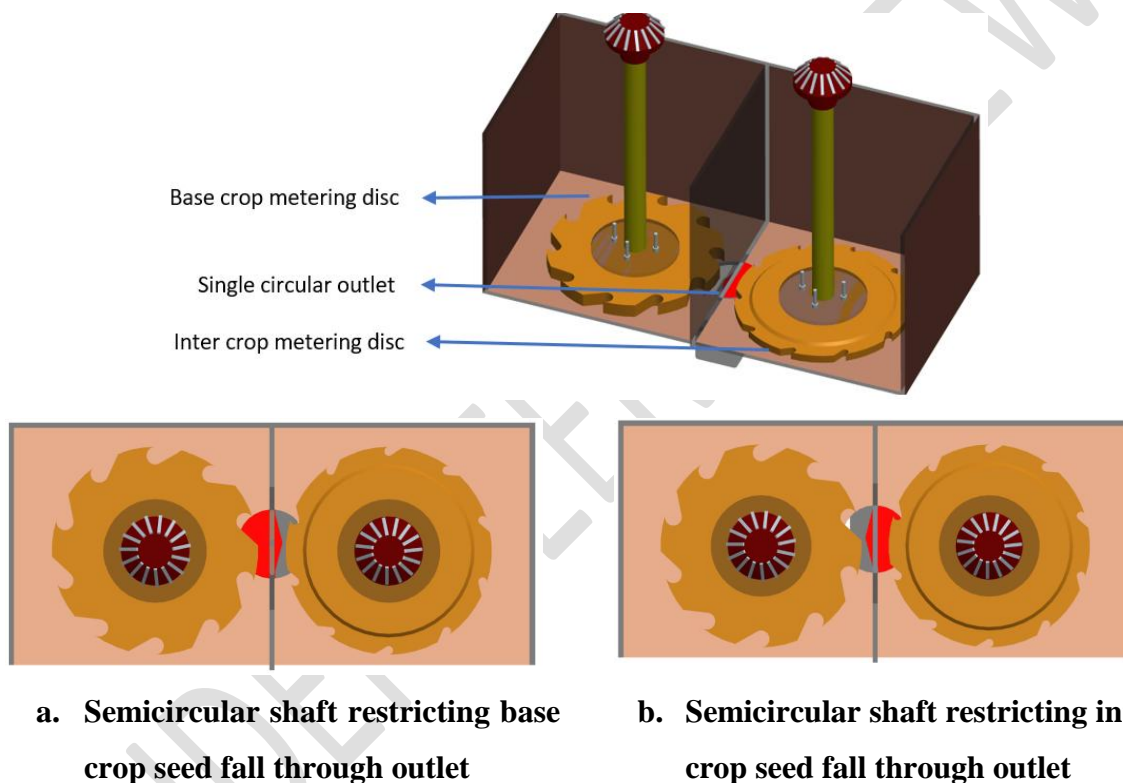

**Fig.1. Seed hopper with two compartments (for two crops) with single outlet**

#### 3.1.2 Micro controller (Arduino Mega 2560):

The Arduino Mega 2560 was an ATmega2560 based microcontroller. It has 15 PWM output pins, 16 analog input pins, 4 UARTs as serial interfacing ports, 16 MHz crystal oscillator with an USB connection for the software uploading, a power jack for the power supply connection and an ICSP header with a reset button (Kusriyanto and Putra, 2016). The Controller gets its power via USB port or through the power jack by connecting the power supply. The uniqueness of Arduino Mega 2560 with other Arduino controllers like Nano and Micro was it has huge memory space to store the source code. The

variable handling was also more because it has 8 KB of SRAM (Adel *et al.*, 2018). It requires 5V of power for its operation. The input voltage is around 7-12V. Each I/O pins had delivered 40 mA DC current to the load. An inbuilt flash memory of 256 KB for the programming storage was available and an 8kb used by the bootloader. Clock speed was around 16 MHz.

### 3.1.3 Servo Motor

Servo motor was an electronic device which was used for the rotation with great precision. It has the control feedback mechanism that provided the necessary feedback on the current position of the motor shaft for its efficient operation and its closed loop mechanism supports linear speed and the position (Liu *et al.*, 2009, Van de Straete *et al.*, 1998). The embedded board inside it controls the movement of the shaft based on the command from the master controller as shown in figure 2. Its operating voltage was 3.3V to 5V.

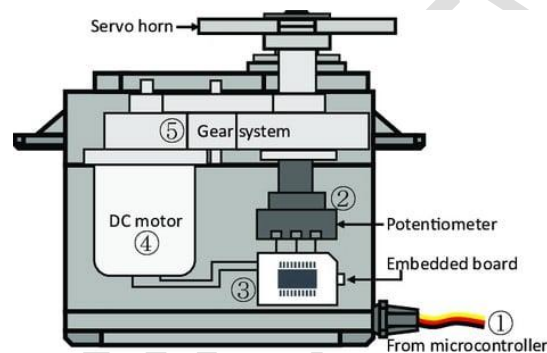

**Fig. 2. Servo Motor**

### 3.1.4 RF transmitter

An RF transmitter module transmits serial data wirelessly through its RF antenna. The transmission rate is between 1kbps – 10 kbps. The transmitter module has three pins namely  $V_{cc}$ , GND and data IN. The  $V_{cc}$  has wide range input supply of 3 to 12V. It consumes 9mA of current for its transmission (Youssef *et al.*, 2018 and Zhuang *et al.*, 2010). The data pin was used to modulated the data signal with ASK modulation and transmit the signal with the carrier signal of 433 Mhz frequency range (Ali *et al.*, 2012).

### 3.1.5 RF receiver

An RF receiver module receives serial data wirelessly through its RF antenna. The receiving rate was 4MHZ. The  $V_{cc}$  has wide range input supply of 3 to 6V. It consumes 3.5mA of current for its reception. The data pin was used to demodulated the data signal obtained from RF transmitter module with ASK demodulation technique and retrieve that signal (Gupta *et al.*, 2010 and Namgoong *et al.*, 2001).

## 3.2 METHODOLOGY

### 3.2.1 Schematic Diagram Transmitter Module:

The Transmitter module schematic diagram as shown in figure 3 is designed by using Circuiti.io app maker (Sorokin *et al.*, 2017). It was an open-source tool also which provides programming code for the schematic circuit. In the Transmitter module the RF transmitter module is connected with Arduino mega which receives the signal form from the input which is given and transmits the output wirelessly. It uses 3.3V for its operation. Five switches were connected in the transmitter module, which were placed on the receiver module. When the switch reads logic 0 i.e., LOW/OFF signal then the controller sends some signals to the receiver module through RF Transmitter. When the switch was ON the Transmitter module continuously sends the signals to the receiver.

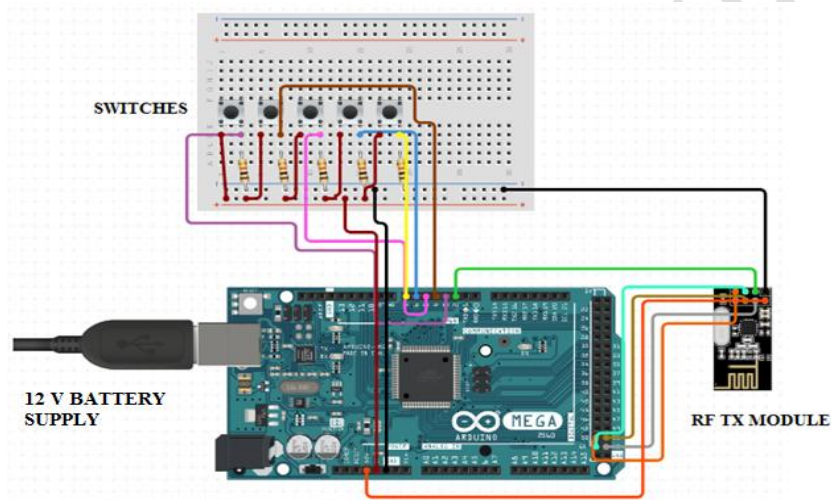

Fig.3. Schematic diagram of Arduino with RF transmitter module

Table 1: Circuit connection map of Arduino Mega with RF Transmitter and Switches

S. No.	Arduino Mega Board	RF Tx Module	Switches (S <sub>1</sub> , S <sub>2</sub> , S <sub>3</sub> , S <sub>4</sub> & S <sub>5</sub> )
1.	5 V	VCC	NC
2.	GND	GND	S <sub>1</sub> , S <sub>2</sub> , S <sub>3</sub> , S <sub>4</sub> & S <sub>5</sub> –GND Logic 0
3.	D <sub>12</sub>	Data IN	NC
4.	D <sub>52</sub>	NC	S <sub>1</sub>
5.	D <sub>50</sub>	NC	S <sub>2</sub>
6.	D <sub>48</sub>	NC	S <sub>3</sub>
7.	D <sub>46</sub>	NC	S <sub>4</sub>
8.	D <sub>44</sub>	NC	S <sub>5</sub>

Note: S<sub>1</sub>, S<sub>2</sub>, S<sub>3</sub>, S<sub>4</sub> & S<sub>5</sub> - Switches; NC – Not Connected; D<sub>12</sub>- Digital Output;

## D<sub>52</sub>, D<sub>50</sub>, D<sub>48</sub>, D<sub>46</sub> & D<sub>44</sub> - Digital Inputs.

### 3.2.2 Schematic Diagram Receiver Module

The Receiver module schematic diagram shown below in Fig. 6 was designed by using Circuitti.io app maker (Sorokin *et al.*, 2017). It was an open-source tool also provides programming code for the schematic circuit. In the RF receiver module, the RF receiver was connected with Arduino mega micro controller board which receives the signals wirelessly from the transmitter module and transmits that to the receiver controller. When the switch was ON, the Transmitter module continuously sends the signals to the receiver, based on that the servo responses.

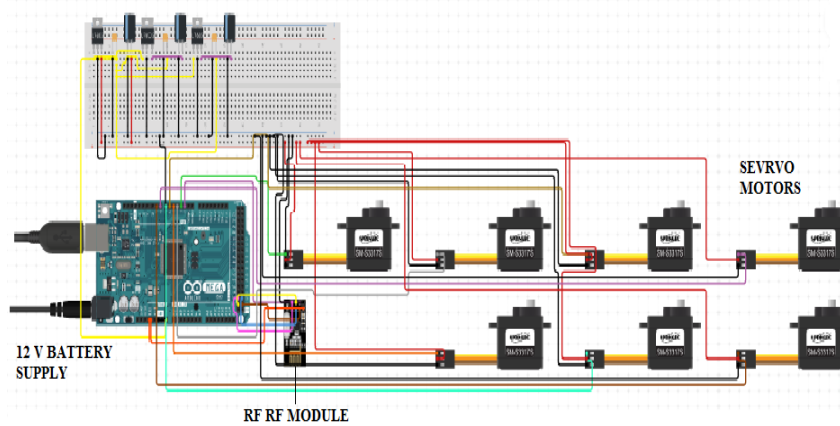

Fig. 4. Schematic diagram of Arduino with RF receiver module

Table 2: Circuit connection map of Arduino Mega with RF receiver and Servo motors

S. No.	Arduino Mega Board	RF Rx Module	Servo Motors SM <sub>1</sub> , SM <sub>2</sub> , SM <sub>3</sub> , SM <sub>4</sub> , SM <sub>5</sub> , SM <sub>6</sub> & SM <sub>7</sub>
1.	5 V	VCC	SM <sub>1</sub> , SM <sub>2</sub> , SM <sub>3</sub> , SM <sub>4</sub> , SM <sub>5</sub> , SM <sub>6</sub> & SM <sub>7</sub> -Vcc
2.	GND	GND	SM <sub>1</sub> , SM <sub>2</sub> , SM <sub>3</sub> , SM <sub>4</sub> , SM <sub>5</sub> , SM <sub>6</sub> & SM <sub>7</sub> -GND
3.	D <sub>11</sub>	Data OUT	NC
4.	D <sub>9</sub>	NC	SM <sub>1</sub>
5.	D <sub>8</sub>	NC	SM <sub>2</sub>
6.	D <sub>7</sub>	NC	SM <sub>3</sub>
7.	D <sub>6</sub>	NC	SM <sub>4</sub>
8.	D <sub>5</sub>	NC	SM <sub>5</sub>

9.	D <sub>4</sub>	NC	SM <sub>6</sub>
10.	D <sub>3</sub>	NC	SM <sub>7</sub>

**Note: D<sub>11</sub>-Data OUT; NC – Not Connected; D<sub>9</sub>, D<sub>8</sub>, D<sub>7</sub>, D<sub>6</sub>, D<sub>5</sub>, D<sub>4</sub>, D<sub>3</sub>- Digital Output; SM<sub>1</sub>, SM<sub>2</sub>, SM<sub>3</sub>, SM<sub>4</sub>, SM<sub>5</sub>, SM<sub>6</sub> & SM<sub>7</sub>-Servo Motors.**

### 3.3 Working

The prototype RF transmitter module and RF receiver module which was shown in the below figures 7 & 8 were developed and were installed in the tractor for controlling seed flow. Here seven row seeder was considered. The transmitter module was placed at the tractor’s driver seat so that it can be operated by the driver. The receiver module with servo motors was placed in the seeder for restricting the seed flow of pre-defined variety. Here we were using 5 switches to control 7 servo motors (where 2 switches S<sub>2</sub> and S<sub>5</sub> can be operated to control 2 servomotors SM<sub>2</sub>, SM<sub>3</sub> and SM<sub>5</sub>, SM<sub>6</sub> each).

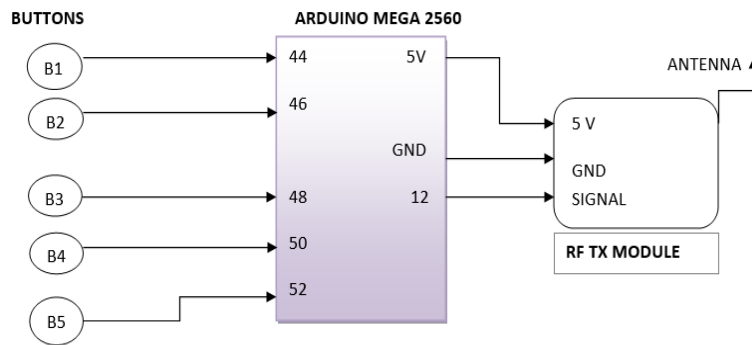

**Fig.5. Block diagram of Arduino with RF transmitter module**

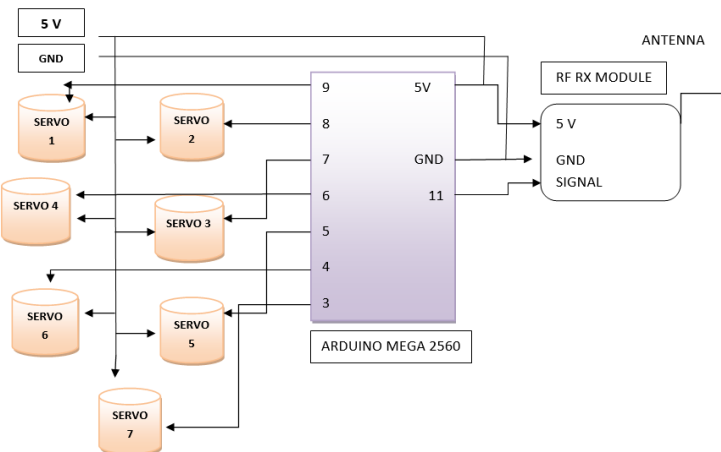

**Fig.6. Block diagram of Arduino with RF receiver module for servo motor control**

## 4. RESULTS AND DISCUSSION

For proper working of the proposed system RF module works by Amplitude shift Keying (ASK) which is an advanced digital method addresses sequential paired information

in the sufficiency of a transporter wave has also been reported by Al Safi and Bazuin (2017) and Lee (2013). It essentially turns ON and OFF, a transporter wave of the steady frequency concerning the two-fold information state 1 and 0. Different libraries are accessible for sequential correspondence utilizing the ASK RF 433 MHZ module and Arduino. Here ~~we~~ **a library is utilized** called “Radiohead” which is one of the most generally utilized Arduino libraries for Rf 433 MHZ. This is the Radio Head Packet Radio library for implanted chip. It gives a total object-oriented library for sending and getting packetized messages through an assortment of normal information radios and different packetized on a scope of inserted microprocessors. Hardware Drivers give low level admittance to a scope of various packet radios and other packetized message transports.

Here the simple sign addresses as alphabetic letters like a, b and so on, are ship off the receiver. An embedded adjustment strategy that sends transmission information by fluctuating the presence/nonappearance of analog signals.

#### **4.1 Functioning of transmitter sketch**

To begin with, incorporate the Radio Head ASK library.

```
#include <RH_ASK.h>
```

This library needs the SPI library to work. Along these lines, additionally incorporate the SPI library.

```
#include <SPI.h>
```

From that point forward, a RH\_ASK object called driver should be done.

In the setup (), introduce the RH\_ASK object by utilizing the init() strategy.

```
Serial.begin (9600);/Debugging only
```

```
if (!driver.init())
```

```
Serial.println("init failed");
```

In loop (), write and send our messages. The message is saved on the variable.

Here the code sends from transmitter must be a character.

```
const char *msg = "a";
```

This message contains the "a" an alphabetic message, yet can send anything need as long as it in the char format.

```
driver.send((uint8_t *)msg, strlen(msg));
```

```
driver.waitPacketSent();
```

The message is being sent each second, yet can adjust this postpone time.

```
delay(1000);
```

## 4.2 Functioning of Receiver sketch

Additionally, to the previous sketch, start by including the fundamental libraries:

```
#include <RH_ASK.h>
```

```
#include <SPI.h>
```

Make a RH\_ASK object called driver:

```
RH_ASK driver;
```

In the arrangement (), introduction of RH\_ASKObject.

```
void setup(){
```

```
Serial.begin(9600);/Debugging only
```

```
if (!driver.init())
```

```
Serial.println("init failed");
```

```
}
```

In the loop(),set a support that coordinates with the size of the message that get.

The buffer size has been adjusted based on the message

```
uint8_t buf[2];
```

```
uint8_t buflen = sizeof(buf);
```

Then, at that point, check the valid message received, if the message is valid then print it serially

```
if (driver.recv(buf, &buflen)) {
```

```
int i;
```

```
Serial.print("Message: ");
```

```
Serial.println((char*)buf);
```

```
}
```

```
int I;
```

```
Serial.print("Message: ");
```

```
Serial.println((char*)buf);
```

```
}
```

Reasonable assumptions were made **when** utilizing this module at the point where the receiver and transmitter are near to one another. When the distance between the transmitter and receiver was increasing disconnection between transmitter and receiver was observed. It depends ~~up~~ on the voltage provided. Placing a suitable size antenna on both the transmitter and receiver circuits avoided this problem. However, the range of RF trans receiver used, is around 500 m.

### 4.3 Header Issue and its Solution

The paper outcome acquired from the proposed system has indicated that the system functioning was precise as well as definitive. In this system, RF transmitter circuit board transmits the signal to the RF receiver circuit board in which servo motor works.

```
“libraries/servo/avr/servo.cpp.o (Symbol from plug in):  
  In function “servo count”: (.text+ 0x0):  
  Multiple definition of – vector – ll”  
  Libraries/Radio Head – master/RH – Ask. Cpp. O (symbol from plugin): (text  
  + 0x0):  
  First defined home collect 2.exe:emr: Id returned 1 exit status  
  Error Compiling`
```

Here in the software code, there is ~~necessary~~ a necessity of using two headers i.e., Radio frequency header and servo motor header. The problem **occurred** in the servo sketch when using two headers especially RH.Ask.h (Radio frequency header) and Servo.h (Servo motor header). When trying to compile the code it shows the error message as (#include <RH.Ask.h>) and (#include <servo.h>).

The servo did not respond in the hardware interfacing too. This was because both the libraries use timer 1 interrupt which created an error issue. In order to overcome that “Servo timer 2.h” header was issued instead of servo.h. Then sketch was compiled and was executed successfully.

### 4.4 Angle conversion

Different servos were operated by different switches and it provided the precise moment of servo shaft. The rotation of the servo shaft was kept as 180° i.e., when switch was ON position then servo shaft rotated to 180° and return to 0° when the switch was turned off as shown in fig 7. The servo shaft position does not vary and remains at specific angle when the servo motor is in working condition. The minimum and maximum pulse widths **were** set to 544 and 2400 micro seconds by the controller and send it to servo. Here, 544 micro seconds was equivalent to 0° and 240 micro seconds was equivalent to 180° theoretically. Whereas in real time when the code was uploaded into the hardware module, the rotation of servo motor was from 0° to 165° only. The similar software interfacing of servo motor with micro controller was experienced by Haider *et al.* (2013).

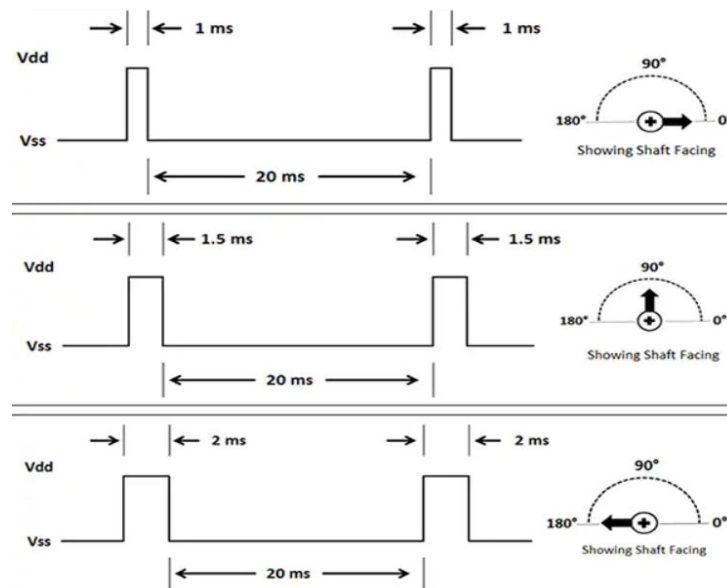

**Fig.7. Servo shaft rotating from 0 to 180°**

#### 4.5 Power Consumption

Also, The power required for each servo, Arduino Mega 2560, RF TX and RX module and others was 1.2 A, 200 mA, 80 mA and 2 A with 5V power each. Where the total battery power required for the system was around 5V 12 A. (Here, we have fixed a voltage regulator is fixed in the circuit in order to convert 12V battery power to 5V battery power as in the tractors they were provided with 12 V battery setup).

The experiment was indicating that the use of these kind of systems was very useful for the farmers to limit the over use of huge mechanical devices or parts in the farm machines so as to increase the productivity and to maintain precise farming. When the servo was placed with appropriate valve mechanism which will restrict the seed drop from seed hopper and also help the farmers by saving the seeds without any losses during headland turns in the field. It also helps the farmer to sow only in the specific rows which ever required. Control systems with RF trans receiver system would be helpful to the farmers for controlling the farm machines from specific distance.

#### 5. CONCLUSION

To control or to stop the seed fall into seed tube electronic devices should be used such as servo motors for high output power relative to motor size, 2-3 times more continuous power for short periods, 5-10 times more rated torque for short periods, achieving high speed at high torque values, quiet at high speeds, providing higher accuracy and resolution with closed loop system. This paper demonstrates how to utilize a wireless technology to control multiple servo motors. In this paper we included the study of transmitter module and receiver

module was included and how it was utilized for proper seedling. Even though using electronic systems was good in agriculture some of the constraints faced are unpredictable when some connections break. So, safety circuits were required when electronic appliances are used in agriculture. Electronic motors can be damaged when exposed to overload. So, selection of appropriate devices as per requirement will give better results.

## **6. COMPETING INTERESTS DISCLAIMER:**

Authors have declared that no competing interests exist. The products used for this research are commonly and predominantly use products in our area of research and country. There is absolutely no conflict of interest between the authors and producers of the products because we do not intend to use these products as an avenue for any litigation but for the advancement of knowledge. Also, the research was not funded by the producing company rather it was funded by personal efforts of the authors.

## **7. REFERENCES**

1. Adel, Z., Hamou, A.A. and Abdellatif, S., 2018, October. Design of Real-time PID tracking controller using Arduino Mega 2560 for a permanent magnet DC motor under real disturbances. In 2018 International Conference on Electrical Sciences and Technologies in Maghreb, pp. 1-5.
2. Ali, A., Saad, N.H., Razali, N.A. and Vitee, N., 2012, December. Implementation of Automatic Meter Reading (AMR) using radio frequency (RF) module. In 2012 IEEE International Conference on Power and Energy, pp. 876-879.
3. Al Safi, A. and Bazuin, B., 2017. Toward digital transmitters with amplitude shift keying and quadrature amplitude modulators implementation examples. In 2017 IEEE 7th Annual Computing and Communication Workshop and Conference, pp. 1-7.
4. Brooker, R.W., Bennett, A.E., Cong, W.F., Daniell, T.J., George, T.S., Hallett, P.D., Hawes, C., Iannetta, P.P., Jones, H.G., Karley, A.J. and Li, L., 2015. Improving intercropping: a synthesis of research in agronomy, plant physiology and ecology. *New Phytologist*, 206(1), pp.107-117.
5. Gupta, D., Kirichenko, D.E., Dotsenko, V.V., Miller, R., Sarwana, S., Talalaevskii, A., Delmas, J., Webber, R.J., Govorkov, S., Kirichenko, A.F. and Vernik, I.V., 2010. Modular, multi-function digital-RF receiver systems. *IEEE transactions on applied superconductivity*, 21(3), pp.883-890.
6. Haidar, A.M., Benachaiba, C. and Zahir, M., 2013. Software interfacing of servo motor with microcontroller. *J. Electrical Systems*, 9(1), pp.84-99.
7. Horwith, B., 1985. A role for intercropping in modern agriculture. *BioScience*, 35(5),

pp.286-291.

8. Karayel, D., Wiesehoff, M., Özmerzi, A. and Müller, J., 2006. Laboratory measurement of seed drill seed spacing and velocity of fall of seeds using high-speed camera system. *Computers and Electronics in Agriculture*, 50(2), pp.89-96.
9. Kusriyanto, M. and Putra, B.D., 2016, August. Smart home using local area network (LAN) based arduino mega 2560. In 2016 2nd International Conference on Wireless and Telematics, pp. 127-131.
10. Lee, Y.C., 2013. 60- GHz amplitude shift- keying transceiver LTCC system- on- package module. *Microwave and Optical Technology Letters*, 55(1), pp.48-51.
11. Liu, J., Zhang, P. and Wang, F., 2009, August. Real-time dc servo motor position control by pid controller using labview. In 2009 International Conference on Intelligent Human-Machine Systems and Cybernetics, Vol. 1, pp. 206-209.
12. Namgoong, W. and Meng, T.H., 2001. Direct-conversion RF receiver design. *IEEE Transactions on Communications*, 49(3), pp.518-529.
13. Praharaj, C.S. and Blaise, D., 2016. Intercropping: An approach for area expansion of pulses. *Indian J. Agron*, 61(4th IAC Special issue), pp.S113-S121.
14. Sorokin, S.V., Sorokina, I.V. and Soldatenko, I.S., Virtual Labs in Engineering Education, 2017.
15. Van de Straete, H.J., Degezelle, P., De Schutter, J. and Belmans, R.J., 1998. Servo motor selection criterion for mechatronic applications. *IEEE/ASME Transactions on mechatronics*, 3(1), pp.43-50.
16. Wang, N., Zhang, N. and Wang, M., 2006. Wireless sensors in agriculture and food Industry-Recent development and future perspective. *Computers and electronics in agriculture*, 50(1), pp.1-14.
17. Willey, R.W., 1990. Resource use in intercropping systems. *Agricultural water management*, 17(1-3), pp.215-231.
18. Youssef, K., Bouchard, L., Haigh, K., Silovsky, J., Thapa, B. and Vander Valk, C., 2018. Machine learning approach to RF transmitter identification. *IEEE Journal of Radio Frequency Identification*, 2(4), pp.197-205.
19. Zhang, N., Wang, M. and Wang, N., 2002. Precision agriculture—a worldwide overview. *Computers and electronics in agriculture*, 36(2-3), pp.113-132.
20. Zhuang, J., Waheed, K. and Staszewski, R.B., 2010. A technique to reduce phase/frequency modulation bandwidth in a polar RF transmitter. *IEEE Transactions on*

UNDER PEER REVIEW