

## Original Research Article

# Effect of different extraction methods on the physicochemical characteristics of *Tetracarpidium conophorum* Müll. Arg. Hutch. and Dalz. almonds oil

### ABSTRACT

*Tetracarpidium conophorum* nut is an oil seed found abundantly in the equatorial forest of Central Africa. The present study was conducted to evaluate the yield and the physicochemical composition oils from *T. conophorum* kernels extracted by cold and hot pressing. The experiments were carried out with mechanical screw press (type – Komet D85-1G) with a nozzle diameter of 8 mm. The extraction method had an influence on oil yield, with a greater yield for hot pressing at 90 °C ( $68.86 \pm 2.00$  %) compared to cold pressing at 30°C ( $64.65 \pm 3.82$  %). The refractive index and the density of oils were not significantly different with respect to the extraction methods. The iodine value varies from 146 for hexane extraction to 170 for cold extraction. For both oils, the acid and peroxide values were in line with Codex standards. The oil extracted with hot press method had higher carotenoid content ( $32.03 \pm 1.86\mu\text{g} / \text{g}$ ).  $\alpha$ -tocopherol was greater in the oil obtained through the cold process ( $16.2 \pm 0.20$  mg/100g). The seed oils contained substantial amounts of polyunsaturated fatty acids, precisely linolenic acid (68% of total fatty acids) and linoleic acid (11% of total fatty acids). Based on its characteristics, oils obtained through cold press extraction was of better quality with respect to preservation of bioactive components. *T. conophorum* oil may have interesting abilities in nutrition, pharmacology and management of metabolic diseases.

**Keys words:** *Tetracarpidium conophorum*, oil, extracting techniques, quality parameters.

## 1. INTRODUCTION

Central Africa Forest contains many endemic oilseed species that are still underexploited. These species with non-industrial exploitation are known as unconventional oilseeds. Among them, is *Tetracarpidium conophorum* Müll. Arg. Hutch. and Dalz., belonging to the Euphorbiaceae family. It is a sarmentous tree that grows in the forest areas of Cameroon, Congo and the West African Coast. The fruits of *T. conophorum* are streaked capsules, green then yellow, when ripe [1].

In Cameroon, *T. conophorum* is found in equatorial climate; mostly in the West and Littoral Regions [1]. In Nigeria, its distribution is more intense in the southern part [2]. The almonds of the fruits are usually eaten boiled or roasted; they are nibbling fruits [1,3] essentially rich in lipids (50.6%) and proteins (23.4%) [4,5].

*T. conophorum* oil contains mainly linolenic acid (70% of total fatty acids) and about 5.7% of saturated fatty acids [4,3,6]. From a nutritional standpoint, the study carried out by Tchankou Leudeu et al. [7] on young male rats showed that *T. conophorum* oil could help against cardiovascular diseases. Oils from these plants could therefore be considered as functional nutrients because they contain essential fatty acids that have the potential to improve health or reduce the risk of disease [8]. Such health benefits can be efficient only if an appropriate extraction technique is implemented to warranty the quality of the oil.

Organic solvents are mostly used for the extraction of vegetable oils. In a current context of limiting the utilization of solvents and looking for suitable processes for the production of heat-sensitive vegetable oils, manufacturers are looking and adopting new alternatives for the oil extractions [9]. Such alternatives include supercritical CO<sub>2</sub> extraction [9,10], assisted enzyme extraction [11], or pressing extraction [12,13,14].

The extraction method using press has the advantage of not modifying the bioactive elements of the oil [15,16,17,18]. As far as our knowledge is concerned no study has not been carried out on extraction using Komet screw press of the oil of *T. conophorum* in relation to the quality of the oil.

Comment [E1]: 3,4,6

Comment [E2]: Leudeu et al.

Comment [E3]: 12-14

Comment [E4]: 15-18

The aim of this study was to evaluate the effect of the extraction methods on the quality parameters of *T. conophorum* oil in order to give an added value to this unconventional oilseed.

## 2. MATERIALS AND METHODS

### 2.1 Materials

The nuts of *T. conophorum* were collected from a local farmer from Melong (Littoral-Region, Cameroon) in September 2019, which is one of the main zones of production and marketing area. This site is at latitude 5°07' 22" North and longitude 9°57' 08" East.

### 2.2 Methods

Fig. 1 summarizes the different operations carried out for extracting oil from *T. conophorum* almonds.

**Comment [E5]:** Different operations carried out for extracting oil from *T. conophorum* almonds were summarized in Fig. 1.

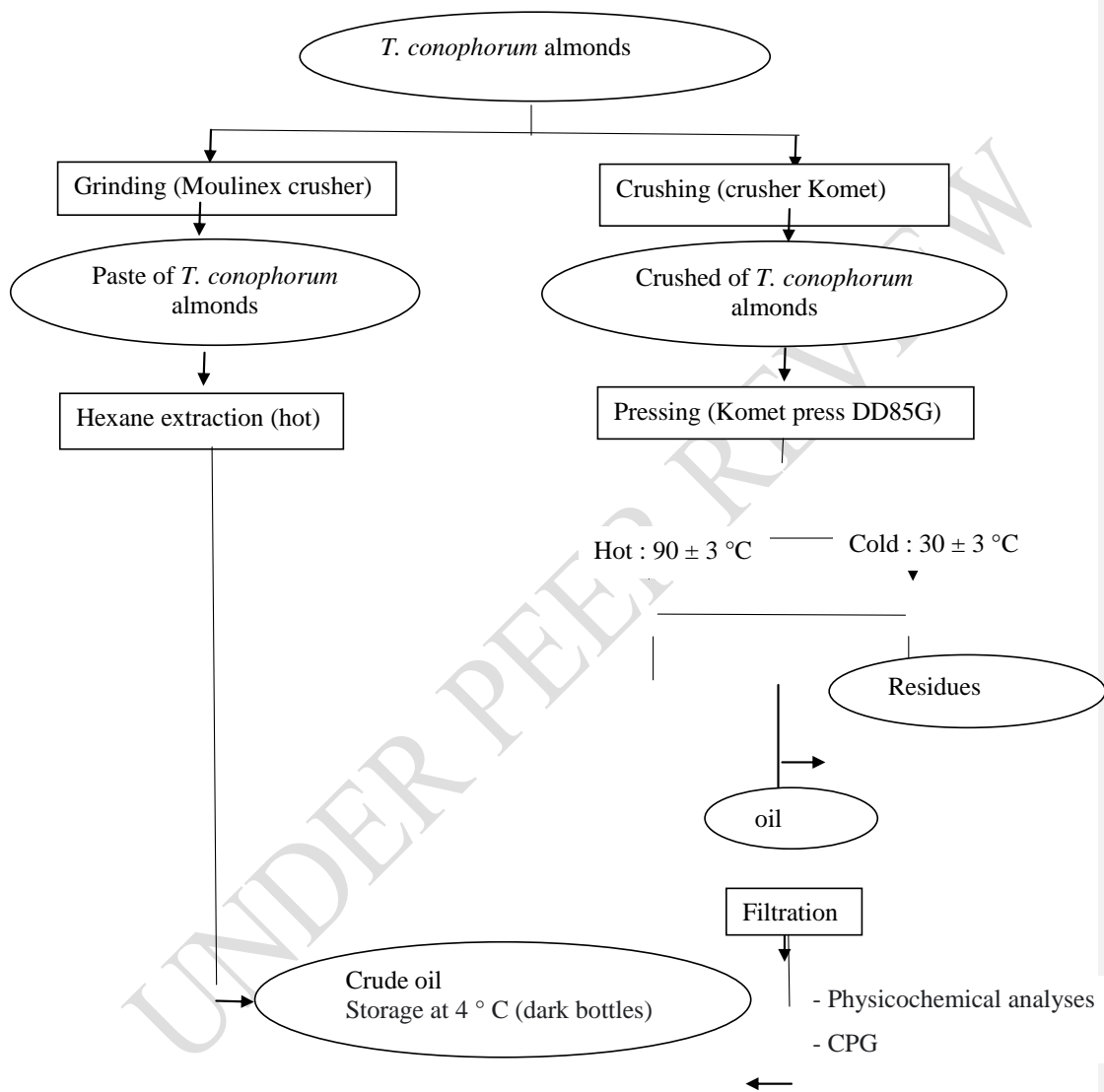

**Fig.1.** Synoptic diagram of the work

**2.3 Mechanical Press extraction Method**

A continuous extraction method using Komet screw press (fig. 2) was implemented to obtain virgin oil from *T. conophorum* seeds. The press screw which is the main part of the machine and its intimate parts are shown on fig. 3. The base of the housing part has an opening where seeds were fed. The oil is collected through another opening in the housing from underneath.



Fig. 2. KOMET screw press [19]

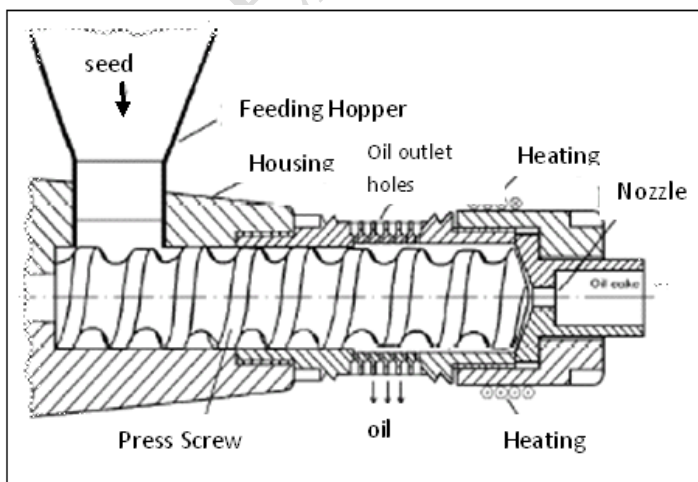

**Fig. 3.** Hole cylinder press of a KOMET oil expeller [19]

*The technical characteristics of the KOMET screw press are:*

- *Weight in Kg (net, without product): 210*
- *Dimension: length (1250), width (600), height (550)*
- *Capacity in Kg products / hour: 20-50*
- *Power in KW: 3*

## **2.4 Treatment of *T. conophorum* almonds**

*T. conophorum* almonds were treated according to the methods described by Tchiegang *et al.* [6]. The nuts were first cooked at 96 °C for 2 hours, then dried at 45 °C for 48 hours in an electric dryer (CKA - 2000 – AUF, ENSAI, University of Ngaoundere). On leaving the dryer, the almonds were obtained after manual shelling.

The dry matter of almond was recorded according to the method of Wolff [20].

## **2.5 Oil extraction methods**

Extraction of oil from almonds was performed by pressing. Soxhlet solvent extraction with hexane was used as standard. Oil yield for each extraction method was estimated as the percentage of extracted oil (g of oil) over the total amount of pressed seeds. For comparison purposes, total seed oil content was estimated with a Soxhlet apparatus [21]. The extraction rate was calculated by making the ratio of the quantity of oil extracted by pressure on the quantity of available oil extracted by solvent [21].

### **2.5.1 Oil extraction by solvent**

The pretreated almonds were pounded in a wooden mortar in order to reduce their sizes, then crushed in a manual mill (SFINX type- France) to obtain a fine powder. These fine powders were extracted with n-hexane in a Soxhlet, following the IUPAC Standard Method [22]. Solvent was separated from oil using a rotary vacuum evaporator. The oil content was determined as described IUPAC [22] and expressed as weight percent on dry basis. This oil was used as control.

### 2.5.2 Oil extraction by cold pressing

In the present experiment, *T. conophorum* seed oil was mechanically obtained using a Komet DD 85 G screw press, number 200666 manufactured in 1991 (Germany). Before extraction, almonds were crushed in a mill brand KOMET, type Crusher, number 200666 manufactured in 1991 (Germany). The samples obtained were immediately pressed at  $30 \pm 3$  °C using a Komet screw press with nozzle size of 8 mm and a screw speed of 20 rpm.

The size of 8 mm nozzle was chosen taking into account the preliminary tests, because it is the one which provided good extraction yield.

Oil obtained were stored at 4 °C in dark vessels. After 48 h, oil was filtered using a sieve to remove other fine particles and then weighed.

Comment [E6]: Delete

Comment [E7]: was

### 2.5.3 Oil extraction by hot pressing

Nozzle diameter was 8 mm. Seeds were fed to the screw press at a seed feeding rate of 20 kg/h a rotational speed of 20 rpm. The head of the screw press was heated to a temperature of  $90 \pm 3$ °C before starting the pressing procedure. The pre-heating process help to fluidify the oil and facilitated their extraction from cells. Pressed oils were stored away from light in a dark container and filtered after 48 h as previously described.

Comment [E8]: helps

Comment [E9]: facilitate

Comment [E10]: oil was

## 2.6 Physical and chemical parameters of oils

- The physico-chemical characteristics of oils including density, refractive index, acid, peroxide, and iodine values were performed according to IUPAC standard methods [22].

- The carotenoid and chlorophyll contents of *T. conophorum* oil were determined by spectrophotometry respectively at 470 nm and 670 nm in acetone using specific extinction values [23].

Comment [E11]: Delete

-  $\alpha$ -tocophérol, which is the most abundant form of tocopherols was determined by colorimetry method [24]. Standard  $\alpha$ -tocopherol solution was used, and optical densities were read at 522 nm. The sample was prepared by dissolving 10 - 40 mg of fat in chloroform.

- Fatty acids were determined by the analytical methods described by Focant *et al.* [25]. Fatty acids were converted to Fatty Acid Methyl Esters (FAMES) before being analyzed. The FAMES were prepared using 10 mL of 1M sodium hydroxide in methanol. Then, 4 mL of 1.2M hydrochloric acid in methanol was added to the mixture according to Focant *et al.* [25] method. After extraction of methyl ester, the chromatograph Thermo Finnigan, type TRACE GC was used to identify fatty acids (Milan, Italy). The capillary column used was RESTEK Rt-2560 (100 m length, 0.25 mm internal diameter, 0.20  $\mu$ m film thickness) (Supelco, Bellefonte, PA, USA). Gas chromatography conditions were a flow rate of 1 mL/min He with an initial temperature of 140°C held for 5 min. The column temperature was then increased to 250°C at a rate of 2°C/min, and then held at 250°C for 15 min. Fatty acid peaks were identified using pure methyl ester standards (Larodan, Belgium).

Comment [E12]: FAMES

Comment [E13]: Delete

Comment [E14]: Delete

## 2.7 Statistical Analysis

All analyses were run in triplicates and all results were reported as mean values  $\pm$  SD. The statistical analysis was performed using a one-way analysis of variance. Duncan's Multiple Range test was performed to evaluate differences between the results. Differences between means were considered to be significant at  $p < 0.05$ .

## 3. RESULTS AND DISCUSSION

Comment [E15]: Reduce the number of paragraphs

### 3.1 Oil extraction yield and rate of *T. conophorum* almonds

Almonds oil yield and oil rate are presented on fig. 4.

Comment [E16]: Merge within the paragraph

The oil content obtained through Soxhlet extraction was  $60 \pm 2$  %. The application of mechanical pressing resulted in similar oil yields, regardless of the temperature employed (heat or cold extraction) at  $p < 0.05$ . Although a slightly high rate was observed for hot extraction ( $70 \pm 2,00$  %) compared to cold extraction ( $61 \pm 3$ %). The value obtained with a water content of almonds between 5 and 6 is higher than that obtained by Fasina and Ajiobola [26] who reported (39%) as on almonds of *T. conophorum* with moisture contents between 8 and 10% after heating using a vertical hydraulic press. On the other hand, the oil

content of cardoon seed oil obtained with the Komet press regardless of the extraction method (cold or hot) was 24% with an extraction rate of 78% [27]. Roncera et al. [28]. found that the oil from the screw press Komet is significantly higher (49.18%) than that get with the hydraulic press (37.94%) for virgin almond oil. It can be explained by the greater interaction of the system with the almonds that are being pressed, because the rotational movement of the screw creates shear forces due to the friction that may contribute to the breaking of the structures of the parenchyma and the liposomes that contain the oil.

Due to its best extraction rate (70 %) and added to higher speed (20-50Kg/h), the KOMET press could be considered as good method for oil extraction from *T. cconophorum* almonds.

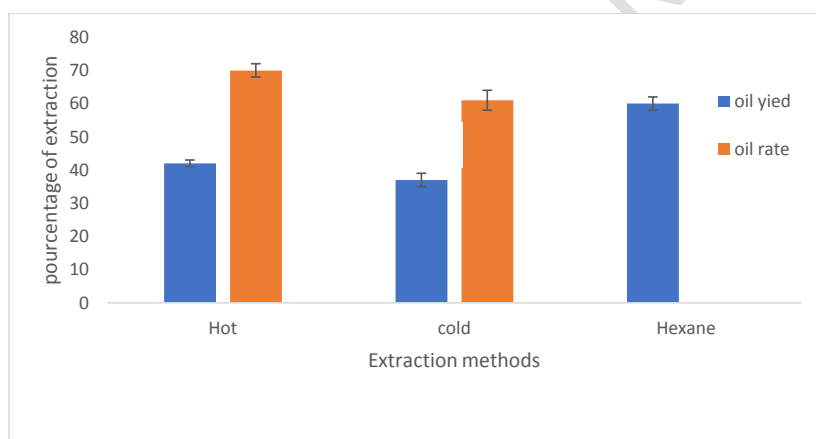

**Fig. 4** Extraction yield and rates of *T. conophorum* almonds oil

### 3.2 Physicochemical characterization of the *T. conophorum* oil

Some quality specifications with respect to different *T. conophorum* oils are shown in

Table 1.

**Comment [E17]:** Merge within the paragraph

Regarding the refractive index which gives information on the purity of oils, it appears from table 1 that the values vary from 1.4640 to 1.462. There is no significant difference regardless of the extraction method ( $p < 0.05$ ).

The density of a fatty substance represents the quotient of its mass by its volume. The density of an oil is a quantity which increases with the length of the fatty acid chains [29]. Regardless of the extraction method, the densities of the different oils are not different according to Duncan's test ( $p < 0.05$ ). The values found were not differ from those of Tchankou Leudeu [30] on oils extracted with hexane from *T. conophorum* ( $0.8292 \pm 0.0002$  g / ml). These favors are lower than that recommended by the Codex Alimentarius [31]. In fact, the density decreases with the increase in unsaturation. From *T. conophorum* contains up to 94% of unsaturated fatty acids. These values are lower than that found in *Riniodendron heudelotti* oil ( $1.002 \pm 0.003$ ) which is a species belonging to the same family as *T. conophorum*. Thus *R. heudelotii* oils has more long chain fatty acids than that of *T. conophorum* [32].

The acid values of the cold and hot extracted oils were not different (0.55). This value is lower than the recommendation of Codex standard which is 4, justifying that these oils contain low free fatty acids content. Thus, the treatments applied to the almonds (cooking and drying) and the methods of extraction (hot and cold pressing) did not alter the quality of the oils. Fantino et al. [33]. showed that the extraction with Komet press for the pistachio gave acid values lower than 0.31.

The iodine value determines the degree of unsaturation of oils. Analysis of variance shows that there is a significant difference ( $p < 0.05$ ) between the different iodine the of oils. The oil extracted with hexane has the smallest value ( $153 \pm 3$ ) compared to that obtained by cold ( $170 \pm 4$ ) and hot ( $177 \pm 4$ ) pressing. In fact, by using heat for a long period (Soxhlet extraction), this can lead to the destruction of the double bonds of their unsaturated fatty acids by producing free radicals

[34]. These results are consistent with those previously obtained with the peroxide index values.

The values found are lower than those of Tchiegang et al. [6] which were between 180 and 182. This can be justified by the botanical origin of the seeds.

The peroxide values were 4.67 and 4.45 meq O<sub>2</sub> per kg of oil respectively for cold, hot extraction. Solvent extracted *T. conophorum* oil had higher peroxide value (13.83 meq O<sub>2</sub> per kg of oil). Similar observations were made by Ghazani et al. [35] on canola which present respectively 3.1 and 6.8 peroxide values for press and solvent extraction. Fasina and Ajiobola [26] using a hydraulic press found a value for peroxide 11 meq O<sub>2</sub> per kg of oil on the same. Fantino et al. [33] using the Komet press states that pistachio oils have peroxide values less than 0.33. Although these values are different, the oils from the Komet press have peroxide values which remain within the standard (15 meq of active O<sub>2</sub> / kg) according to FAO [36]. This difference reflects the degree of oxidation which is also influenced by many factors such as the conditions of obtaining and processing raw materials, the presence of oxygen, light and certain metals [37] and also, by the very nature of the peroxides formed during the primary oxidation phase which are very unstable compounds [29].

Plant oils are usually coloured by pigments such as tocopherol, carotenoid and chlorophyll. These substances play an important role by reducing oxidative activity [38].

$\alpha$ -Tocopherols are natural antioxidants found in vegetable oils. The oil from cold pressing has the highest value (16.1  $\pm$  0.20mg / 100g) followed by the hot pressing (15.2  $\pm$  0.30mg / 100g). The oil extracted with hexane has the lowest value (14.8  $\pm$  0.10mg / 100g). This shows that the extraction technic affects the  $\alpha$ -tocopherol content. Similar observations were made by Rezig et al. [39] on *Cucurbita maxima* Pumpkin seed oil where the  $\gamma$ -tocopherol contents were 599.33 mg/kg<sup>-1</sup> and 239.60 mg/kg<sup>-1</sup> respectively for cold extraction with the Komet press and hexane. Linseed oil contains 1 mg / 100 g of  $\alpha$ -tocopherol and 50 mg / 100 g of  $\gamma$ -tocopherol [40]. The results found showed that the extraction technic affects significantly the tocopherol content.

Carotenoid and chlorophyll play an important role in the oxidative activity because of their antioxidant nature in the dark and pro-oxidant activity in the light [38].

The analysis of variance shows that there is a significant difference ( $p < 0.05$ ) between the total carotenoid and total chlorophyll contents of the oils obtained.

The oil extracted from hot pressing has the highest content of carotenoids ( $32.03 \pm 1.86 \mu\text{g} / \text{g}$ ) compared to that from cold pressing ( $21.43 \pm 1.789 \mu\text{g} / \text{g}$ ) and hexane ( $8.05 \pm 0.56 \mu\text{g} / \text{g}$ ). Rezig et al. [39]. reported  $27.48 \text{ mg kg}^{-1}$  in Pumpkin Seed oil hexane extraction. Palm oil with its red color, has a very high carotenoid content between 500 - 2000 mg / kg [41].

For total chlorophyll, the oil extracted with hexane has the lowest value ( $1.266 \pm 0.12 \mu\text{g} / \text{g}$ ) compared to the two other extraction methods which are cold ( $2.75 \mu\text{g} / \text{g}$ ) and hot ( $2.82 \mu\text{g} / \text{g}$ ) pressing. This suggests that hexane must have leached out some chlorophyll. These low contents are desired in order to avoid the pro-oxidant action of the chlorophyll pigments and thus to ensure good preservation of the oils [42]. These values are lower than those found in the oil from *Dacryodes edulis* fruits (Burseraceae) ( $30.33 \pm 2.53 \mu\text{g} / \text{g}$ ) [30] and in canola oil ( $44.4$  and  $34.4 \text{ mg} / \text{kg}$ ) [35]. This decrease is accompanied by an increase in the carotenoids contents which give the oil its yellow color at the expense of the chlorophyll green color [43].

**Table 1** Some physicochemical characteristics of oils from *T. conophorum* almonds with respect to extraction methods.

	Extractions methods			Codex Alimentarius Standard, 2019
	Cold (30°C)	Hot (90°C)	Hexane	
<b>Refractive index</b>	$1.4642 \pm 0.0009^a$	$1.4640 \pm 0.0007^a$	$1.4642 \pm 0.0009^a$	1.459-1.460
<b>Density (g/ml)</b>	$0.8168 \pm 0.0002^a$	$0.8168 \pm 0.0004^a$	$0.8166 \pm 0.0002^a$	0.886-0.900
<b>Acid value</b>	$0.55 \pm 0.01^a$	$0.54 \pm 0.02^a$	$0.42 \pm 0.01^b$	4
<b>Iodine value</b>	$170 \pm 4^a$	$177 \pm 4^a$	$153 \pm 3^b$	

<b>Peroxide value (meq O<sub>2</sub> per kg of oil)</b>	4.67 ± 0.14 <sup>b</sup>	4.45 ± 0.10 <sup>b</sup>	13.83 ± 0.50 <sup>a</sup>	15
<b>α-tocophérol (mg/100g)</b>	16.10 ± 0.20 <sup>a</sup>	15.20 ± 0.30 <sup>b</sup>	14.82 ± 0.10 <sup>b</sup>	
<b>Carotenoïds (µg/g)</b>	21.43 ± 1.79 <sup>b</sup>	25.03 ± 1.86 <sup>a</sup>	18.05 ± 0.60 <sup>c</sup>	
<b>Chlorophyll (µg/g)</b>	2.75 ± 0.25 <sup>a</sup>	2.80 ± 0.211 <sup>a</sup>	1,66 ± 0.125 <sup>b</sup>	

Values are means ± SD of three determinations. Values on the same line with different superscripts are significantly different at  $p < 0.05$  (Duncan's test)

### 3.3 Fatty acids composition

The fatty acid compositions of *T. conophorum* almonds oils are compared in table 2 with regard to the extraction method.

Of the saturated fatty acids, the minors are capric, lauric and arachidic acid. They vary very little regardless of the extraction method. Stearic acid is the major with 3,67% (in cold extraction) to 4 % (in hot extraction). There is no significant difference cooking the extraction method. The pourcentage of this fatty acid is higher than those found by other authors [6, 30] in the same oil.

Among the monounsaturated fatty acids (14-15% of total fatty acids), oleic acid occurs in greatest amounts, from 14.08 % (in hexane extraction) to 14.73% (in hot extraction). The concentration of oleic acid (14.08) is higher than 10.81 % reported by Tchankou Leudeu [30] for to *T. conophorum* oil.

Polyunsaturated fatty acids represents 78 to 80% of total fatty acids, α-linolenic acid (ω-3) was the most abundant of all fatty acids (67.36% - 68.80%) in this oil. There is not a

**Comment [E18]:** Merge within the paragraph

significant difference of this fatty acid whatever the mode of extraction. *T. conophorum* oil is richer in  $\alpha$ -linolenic acid than linseed (54%), walnut (9-15%) and rapeseed (8-10%) oil [40].

Linoleic and palmitic acids are commonly used as indicators of oil deterioration, due to their sensitivity and oxidative stability, respectively. Thus, the C18: 2 / C16: 0 ratio is 5.55 which is higher than that of palm oil (0.25), *D. edulis* (0.56) [30]. This indicates the high susceptibility of *T. conophorum* oil to oxidation.

This oil, because of its linolenic acid content, could have important properties in the management of some metabolic diseases [44, 45].

UNDER PEER REVIEW

Composition (%)			
Fatty acids	Hot-pressed	Cold- pressed	Solvent-extraction
<b>C10:0</b>	0.05 ± 0.00 <sup>b</sup>	0.06 ± 0.00 <sup>a</sup>	0.06 ± 0.00 <sup>a</sup>
<b>C12:0</b>	0.02 ± 0.00 <sup>a</sup>	0.02 ± 0.00 <sup>a</sup>	0.01 ± 0.00 <sup>b</sup>
<b>C14:0</b>	0.03 ± 0.00 <sup>a</sup>	0.02 ± 0.00 <sup>b</sup>	0.02 ± 0.00 <sup>b</sup>

**Table 2:** Fatty acid composition of different *T. conophorum* almond oils (%/100 g of oil)

<b>C16 :0</b>	1.99 ± 0.01 <sup>a</sup>	1.83 ± 0.02 <sup>b</sup>	1.98 ± 0.02 <sup>a</sup>
<b>C16 :1C9</b>	0.03 ± 0.00 <sup>a</sup>	0.01 ± 0.00 <sup>b</sup>	0.01 ± 0.00 <sup>b</sup>
<b>C18 :0</b>	4.00 ± 0.11 <sup>a</sup>	3.67 ± 0.10 <sup>b</sup>	3.71 ± 0.20 <sup>ab</sup>
<b>C18 :1C9</b>	14.73 ± 0.30 <sup>a</sup>	14.35 ± 0.15 <sup>ab</sup>	14.08 ± 0.18 <sup>b</sup>
<b>C18 :1C11</b>	0.42 ± 0.01 <sup>a</sup>	0.42 ± 0.01 <sup>a</sup>	0.41 ± 0.01 <sup>a</sup>
<b>C18 :2C9C12</b>	11.10 ± 0.12 <sup>a</sup>	10.56 ± 0.18 <sup>b</sup>	10.72 ± 0.21 <sup>ab</sup>
<b>C20 :0</b>	0.18 ± 0.00 <sup>a</sup>	0.16 ± 0.00 <sup>b</sup>	0.15 ± 0.00 <sup>c</sup>
<b>C18 :3C9C12C15</b>	67.36 ± 0.22 <sup>b</sup>	68.80 ± 0.17 <sup>a</sup>	68.76 ± 0.10 <sup>a</sup>
<b>C20:3C11C14C17</b>	0.08 ± 0.00 <sup>a</sup>	0.08 ± 0.00 <sup>a</sup>	0.08 ± 0.00 <sup>a</sup>
<b>C20:5C5C8C11C14C17</b>	0.02 ± 0.00 <sup>a</sup>	0.02 ± 0.00 <sup>a</sup>	0.01 ± 0.00 <sup>b</sup>
<b>Σ Saturated (%)</b>	<b>6.26</b>	<b>5.76</b>	<b>5.93</b>
<b>Σ Monounsaturated (%)</b>	<b>15.18</b>	<b>14.78</b>	<b>14.50</b>
<b>Σ Polyunsaturated (%)</b>	<b>78.56</b>	<b>79.46</b>	<b>79.57</b>
<b>C18 : 2 / C16 : 0</b>	<b>5.57</b>	<b>5.77</b>	<b>5.41</b>

Values are means ± SD of three determinations. Values on the same line with different superscripts are significantly different at  $p < 0.05$  (Duncan's test)

#### 4. CONCLUSION

This study showed that the method of extracting oil from *T. conophorum* almonds could influence the oil quality with respect to extraction conditions due to the processing temperature in the screw press extraction. Regardless of the pressing extraction method, the acid and peroxide numbers meet Codex standards. Regarding vitamin E content, the oil considered as rich source of  $\alpha$ -tocopherols. Almonds oil can be considered a potential source of-3 due to its high content in  $\alpha$ -linolenic acid (68%). The cold Komet press extraction method (30°C) appears to be an alternative to the use of solvents. The high content of these bioactive compounds underline both their nutritional value and medicinal values.

Comment [E19]: to extraction conditions

#### REFERENCES

1. Vivien J, Faure JJ. Fruitiers sauvages d'Afrique. Espèces du Cameroun. Coopération Française, CTA, 1996; 416 p.

2. Akpuaka MU, Nwankwor E. Extraction, analysis and utilisation of a drying – oil from *Tetracarpidium conophorum*. *Bioresource Technology*. 2000; 73:195–196.
3. Enujiugha VN. Chemical and Functional Characteristics of Conophor Nut. *Pakistan Journal of Nutrition*. 2003; 2(6): 335-338.
4. Ige MM, Ogunsua AO, Oke OL. Functional properties of proteins of some Nigerian oilseeds: Conophor seeds and three varieties of Melon seeds. *J. Agric. Food Chem*. 1984; 32: 822 - 825.
5. Mezajoug Kenfack LB. Etude de quelques propriétés chimiques et fonctionnelles des amandes et du tourteau de *Ricinodendron heudelotii* (Bail.) et de *Tetracarpidium conophorum* (Müll. Arg.). Mémoire de Maîtrise de Biologie Appliquée, Faculté des Sciences, Université de Ngaoundéré (Cameroun), 2000, 52 p.
6. Tchiegang C, Kapseu C, Parmentier M. Chemical composition of oil from *Tetracarpidium conophorum* ((Müll Arg.) Hutchand Dalz.) nuts. *J. Foods Lipids*. 2001; 8: 95 - 102.
7. Tchankou Leudeu BC, Tchiegang C, Barbe F, Nicolas B, Parmentier M, Gueant JL. Effect of two dietary oils from: *Ricinodendron heudelotii* (Bail.) and *Tetracarpidium Conophorum* Müll. nuts on some biochemical blood parameters of rats. *Journal of Nutrition Research*. 2009; 29: 503-509.
8. Jennifer A. Fleming, Penny M. Kris-Etherton. The Evidence for  $\alpha$ -Linolenic Acid and Cardiovascular Disease Benefits: Comparisons with Eicosapentaenoic Acid and Docosahexaenoic Acid. *Adv. Nutr*. 2014; 5:863–876.
9. Mitra P, Ramaswamy HS, Chang KS. Pumpkin (*Cucurbita maxima*) seed oil extraction using supercritical carbon dioxide and physicochemical properties of the oil. *Journal of Food Engineering*. 2009; 95:208-213.
10. Jianlou Mu, Gang Wu, Zhizhou Chen, Charles Brennan, Khanh Nhu Tran, Nadeesha Dilrukshi, et al. Identification of the Fatty Acids Profiles in Supercritical CO<sub>2</sub> Fluid and Soxhlet Extraction of Samara Oil from Different Cultivars of *Elaeagnus mollis* Diels Seeds. *Journal of Food Composition and Analysis*. 2021; 101(8):103982.

Comment [E20]: Revise

Comment [E21]: Leudeu BCT

11. Jiao Jiao, Zhu-GangLi, Qing-YanGai, Xiao-JuanLi, Fu-YaoWei, Yu-JieFu, WeiMa. Microwave-assisted aqueous enzymatic extraction of oil from pumpkin seeds and evaluation of its physicochemical properties, fatty acid compositions and antioxidant activities. *Food Chemistry*. 2014;147: 17-24.
12. Neđeral S, Petrović M, Vincek D, Pukec D, Škevin D, Kraljić K, et al. Variance of quality parameters and fatty acid composition in pumpkin seed oil during three crop seasons. *Industrial Crops and Products*. 2014; 60:15-21.
13. Rabrenović BB, Dimić EB, Novaković MM, Tešević VV, Basić ZN. The most important bioactive components of cold pressed oil from different pumpkin (*Cucurbita pepo* L.) seeds. *Food Science and Technology*. 2014; 55(2):521-527.
14. Bhuiya MMK, Rasul M, Khan M, Ashwath N, Mofijur M. Comparison of oil extraction between screw press and solvent (n-hexane) extraction technique from beauty leaf (*Calophyllum inophyllum* L.) feedstock. *Industrial Crops and Products*. 2020; 144,112024.
15. Tchiegang C, Ngo Oum M, Aboubakar Dandjouma A, Kapseu C. Qualité et stabilité de l'huile extraite par pressage des amandes de *Ricinodendron heudelotii* (Bail.) Pierre ex Pax pendant la conservation à température ambiante. *Journal of Food Engineering*. 2004; 62 (1) :69-77.
16. Nitiéma-Yefanova Svitlana, Gouyahali Son, Siédouba Yé, Roger HC. Nébié, Yvonne Bonzi-Coulibaly. Optimisation des paramètres d'extraction à froid de l'huile d'*Azadirachta indica* A. Juss et effets sur quelques caractéristiques chimiques de l'huile extraite. *Biotechnol. Agron. Soc. Environ*. 2012; 16(4): 423-428.
17. Santos Fernandes S, Tonato D, Marcio A. Mazutti, Rogério de Abreu B, Diego da Costa Cabrera, Caroline Da Ros Montes D'Oca et al. Yield and quality of chia oil extracted via different methods. *Journal of Food Engineering*. 2019; 262 : 200-208.
18. Isam A. Mohamed Ahmed, Mehmet Musa Özcan, Fahad AlJuhaimi, Kashif Ghafoor, Elfadil E. Babiker, Magdi A. Osman et al. Quality characteristics of caper seed

Comment [E22]: Revise

Comment [E23]: Revise

Comment [E24]: Revise

Comment [E25]: Revise

oils—The impact of extraction: Soxhlet versus cold pressing. *Journal of Food Processing and Preservation*. 2021; 45:1-9.

19. IBG Monforts Oekotec GmbH & Co. KG. <[www.oekotec.ibg-monforts.de](http://www.oekotec.ibg-monforts.de)>. 2003.
20. Wolff JP. *Manuel d'analyse des corps gras*. Azouley éditeur, Paris (France). 1968; 519p.
21. Wiemar HJ, Altes KFW. *Méthodes artisanales de transformation des oléagineux*. Gate/GTZ, Eschborn (Allemagne Fédérale) 1993; 134p.
22. IUPAC (International Union of Pure and Applied Chemistry). *Méthodes d'analyses des matières grasses et dérivées* » (6<sup>e</sup> éd.). Lavoisier, Paris (France): Tec et Doc. 1979; 190p.
23. Rossell JB. *Classical Analysis of Oils and Fats: in Analysis of Oils and Fats* (Eds. Hamilton R. J. and Rossell J. B.), Elsevier Applied Science Publishers LTD, New York, USA. 1986; 441 p.
24. Kivçak B, Mert T. Quantitative determination of  $\alpha$ -tocopherol in *Arbutus unedo* by TLC-densitometry and colorimetry. *Fitoterapia*. 2001; 72: 656 - 661.
25. Focant M, Mignolet E, Marique M, Clabots F, Breyne T, Dalemans D, Larondelle Y. The effects of Vitamin E Supplementation of Cow Diets Containing Rapeseed and Linseed on the Prevention of Milk Fat Oxidation». *Journal of Dairy Science*. 1998; 81: 1095- 1101.
26. Fasina OO, Ajibola OO. Mechanical Expression of Oil from Conophor Nut (*Tetracarpidium Conophorum*) *J. agric. Engng Res*. 1989; 44: 275-287.
27. Petropoulos SA, Fernandes Â, Calhelha RC, Danalatos N, Barros L, Ferreira ICFR,. How extraction method affects yield, fatty acids composition and bioactive properties of cardoon seed oil? *Industrial Crops and Products*. 2018; 124: 459–465.
28. Roncero JM, Álvarez-Ortí M, Pardo-Giménez A, Rabadán A, Pardo JE.. Influence of Pressure Extraction Systems on the Performance, Quality and Composition of Virgin Almond Oil and Defatted Flours. *Foods*. 2021; 10: 1-14.
29. Cheftel JC, Cheftel H. *Introduction à la Biochimie et à la Technologie des Aliments*. Vol 1, Tec. et Doc., Lavoisier, septième tirage, Paris (France), 1984; 381p.

Comment [E26]: Revise

30. Tchankou Leudeu BC. Etude sur des jeunes rats males des propriétés nutritionnelles des huiles de *Canarium schweinfurthii* Engl., *Dacryodes edulis* (G. Don) H. J. Lam, *Ricinodendron heudelotii* (Bail.) Pierre ex Pax, et *Tetracarpidium conophorum* Müll. Arg. Hutch. and Dalz ». Thèse de Doctorat, Ecole Nationale Supérieure des Sciences Agro Industrielles (ENSAI), Université de Ngaoundéré (Cameroun). 2006; 259 p.
31. Codex Alimentarius. Programme mixte FAO/OMS sur les normes alimentaires : rapport de la vingt-sixième session du comité du Codex sur les graisses et les huiles. Commission du Codex Alimentarius quarante-deuxième session CICG, Genève, Suisse. REP19/FO. 2019; 1- 62 pp.
32. Nzali Ghomdim H, Tchiegang C, Sandjon B, Meurens M. Comparison of some physicochemical properties of oil extracted from *Ricinodendron heudelotii* (Bail.) kernels by UV spectrophotometer. International Journal of Biosciences. 2016; 8(6): 93-102.
33. Fantino VM, Bodoira RM, Penci MC, Ribotta PD, Martínez ML. Effect of screw-press extraction process parameters on the recovery and quality of pistachio oil. Grasas Aceites. 2020; 71(2):1-12.
34. Tynek M, Hazuka Z, Pawlowicz R, Dudek M. Changes in the frying medium during deep-frying of food rich in proteins and carbohydrates. J. Food. Lipids. 2001; 8(4): 251-261.
35. Ghazani SM, Llatas GG, Marangoni AG. Micronutrient content of cold-pressed, hot-pressed, solvent extracted and RBD canola oil: Implications for nutrition and quality. Eur. J. Lipid Sci. Technol. 2014;116: 380–387.
36. FAO (Food and Agriculture Organization). Avant-projet de normes pour les huiles végétales portant un nom spécifique. 1992; 7 p.
37. Wolff JP. Analyse et dosage des lipides : in Technique d'analyse et de dosage dans les industries agro-alimentaires IV : analyse des constituants alimentaires, Lavoisier, Tec. et Doc. Paris (France). 1991; 221p.

Comment [E27]: Revise

Comment [E28]: Revise

38. Oueslati I, Anniva C, Daoued D, Tsimidou MZ, Zarrouk M. Virgin olive oil (VOO) production in Tunisia: the commercial potential of the major olive varieties from the arid Tataouine zone. *Food Chemistry*. 2009; 112:733-741.
39. Rezig L, Chouaibi Moncef, Ojeda-Amador RM, Gomez-Alonso S, Salvador M. Desamparados, Fregapane Giuseppe et al. *Cucurbita maxima* Pumpkin Seed Oil: from the Chemical Properties to the Different Extracting Techniques. *Not Bot Horti Agrobo*. 2018; 46(2):663-669.
40. Morin O. Caractéristiques des huiles de lin et de chanvre. *OCL*. 2015; 22(6) 608: 1-6.
41. Lecerf JM. Palm oil: Nutritional and metabolic aspects. Role for cardiovascular risk. *OCL*. 2013; 20(3):147–159.
42. Kiritsakis A, Markakis P. Olive oil: a review. *Advance Food Research*. 1987; 31:118-125.
43. Tanouti K, Elamrani A, Serghini-Caid H. Caractérisation d'huiles d'olive produites dans des coopératives pilotes (Lakrarma et Kenine) au niveau du Maroc Oriental. *Les Technologies de Laboratoire*. 2010; 5 (18) :18-26.
44. Hao Y, Bin Q, Min J, Wei L, Xiao-Fei G, Na L et al. Effects of  $\alpha$ -linolenic acid intake on blood lipid profiles : a systematic review and meta-analysis of randomized controlled trials. *Critical Reviews in Food Science and Nutrition*. 2020; 61(17):2894-2910.
45. Rong Fan, Judy Kim, Mikyoung You, David Giraud, Ashley M Toney, Seung-Ho Shin et al.  $\alpha$ -Linolenic acid-enriched butter attenuated high fat diet-induced insulin resistance and inflammation by promoting bioconversion of n-3 PUFA and subsequent oxylipin formation. *Journal of Nutritional Biochemistry*. 2020; 76: 108285.

Comment [E29]: Revise