

Influence of diffusion layer and other structural parameters on performance of hydrogen fuel cell

ABSTRACT

Aims: Gas diffusion layer (GDL), catalytic layer (CL) and proton exchange membrane (PEM) are important components of hydrogen fuel cell (HFC). In this paper, the thickness of the diffusion layer, the catalytic layer and the proton exchange membrane of the hydrogen fuel cell are mainly simulated and analyzed, and the structural parameters with relatively good performance of the hydrogen fuel cell are obtained.

Place and Duration of Study: North China University of Water Resources and Electric Power, Zhengzhou, Henan Province, between November 2021 and March 2022.

Methodology: Fuel cell models with different diffusion layers, catalytic layers and proton exchange membrane thicknesses were established by ANSYS, and simulated and analyzed them in the PEMFC module in Fluent, comparing the temperature distribution, water distribution and current density distribution of hydrogen fuel cells with diffusion layer thickness, catalytic layer thickness and proton exchange membrane thickness, and comparing the structural parameters with relatively good performance of hydrogen fuel cells.

Conclusion: The results show that the thicker the diffusion layer is, the more unfavorable the product water is discharged, which hinders the diffusion of oxygen and reduces the performance of fuel cell; The larger the thickness of the catalytic layer, the higher the current density and the better the performance of the hydrogen fuel cell; The larger the thickness of proton exchange membrane, the negative effect on the diffusion of reactive gas, the lower the reaction efficiency and current density of fuel cell, and the lower the performance of fuel cell.

Keywords: Hydrogen fuel cell; Diffusion layer; Catalytic layer; Proton exchange membrane

1. INTRODUCTION

Among the many new energy sources, hydrogen energy is of superb research value as an efficient and clean renewable energy source. It is valued by researchers, governments and companies in many countries because it meets the need for climate mitigation and sustainable development. Hydrogen can be produced in a variety of ways, from reforming coal, oil and natural gas, from electrolysis of water, from the purification of waste gas from industries containing hydrogen, and from biological methods^[1-3]. There are currently two main types of hydrogen energy exploitation: the first is the most direct and simple, which is the direct burning of hydrogen for exothermic purposes, and the second is the use of hydrogen fuel cells, which convert hydrogen energy into electricity through a reaction^[4].

This process of generating electricity by hydrogen fuel cells is not limited by the Carnot cycle, which essentially increases the efficiency of energy conversion. In addition, hydrogen fuel cells use hydrogen and oxygen as fuel, the product is only clean water, almost no emissions of nitrogen oxides and other gases that pollute the atmosphere, so for today's development strategy of energy saving and emission reduction, the research of hydrogen

fuel cells has great significance^[5]. Rui Jiao YU studied the influence of electrical conductivity, thermal conductivity, permeability and diffusion coefficient on the overall performance of the battery through numerical simulation^[6]. Gaojian Chen, Qian Xu et al. studied the complex relationship between the uneven deformation and change of the physical properties of the gas diffusion layer, and based on Bruggman's formula, introduced a modified diffusion coefficient to describe the effect of species concentration change on the effective diffusion coefficient^[7]. Prince Abraham B, Kalidasa Murugavel K Et al. studied the Influence of Catalyst Layer and Gas Diffusion Layer Porosity in Proton Exchange Membrane Fuel Cell Performance^[8]. Zhiming Bao, Yanan Li Et al. numerically estimated the effect of compression on different transport properties of GDL^[9]. Like Yue, Shixue Wang Et al. studied the effect of the position of the cathode GDL hydrophobic area relative to the channel on the fuel cell performance^[10]. The membrane electrode, as an important structure of the hydrogen fuel cell, affects the performance of the fuel cell, so the investigation of the influence of the structure of the membrane electrode on the fuel cell is to find the universal law from it and optimize the structural parameters, so as to improve the performance of the fuel cell^[11-15].

In this paper, a fuel cell model with different diffusion layer, catalytic layer and proton exchange membrane thicknesses is developed by ANSYS and simulated in the PEMFC module of Fluent to compare the temperature distribution, water distribution and current density distribution of the diffusion layer, catalytic layer and proton exchange membrane thicknesses on the hydrogen fuel cell, and to compare the structural parameters that are relatively good for the performance of the hydrogen fuel cell.

2. MODEL BUILDING

2.1 Geometric models

A single-flow channel proton exchange membrane fuel cell model with length, width and height of 125mm, 2.4mm and 3mm respectively is used in this model, as shown in Figure 1, the internal structure is shown in Figure 2 and the model parameters are shown in Table 1. The calculation area includes: cathode and anode runners, cathode and anode diffusion layer, cathode and anode catalytic layer, and proton exchange membrane.

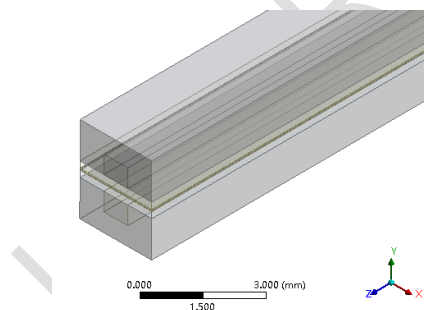

Fig. 1. Model diagram of the hydrogen fuel cell section

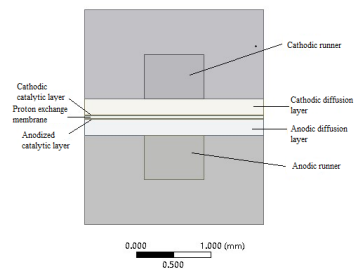

Fig. 2. Schematic diagram of the fuel cell structure

Table 1. Structural parameters

Name of structure	Long/mm	Wide/mm	High/mm
-------------------	---------	---------	---------

2.2 Meshing

This time the model is in the form of a hexahedral grid, and the lines of the model are forced to be divided. Table 2 shows the current density values for different grid quantities at the same voltage input, and the local grid of the fuel cell is encrypted (Figure 3), the results show that the difference in current density of the hydrogen fuel cell on the membrane for different grids is within 0.3%, and the grid meets the independence requirements.

Table 2. Grid validation

Number of meshes	6.6×10 ⁴	7.2×10 ⁴	7.9×10 ⁴
------------------	---------------------	---------------------	---------------------

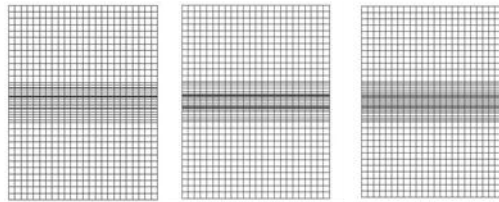

Fig. 3. Model division with different number of meshes

2.3 Boundary conditions and physical parameters

The PEMFC module of Fluent was used to simulate the operation of hydrogen fuel cells. The types of yin and yang bipolar runner inlet boundaries are mass-flow-inlet, and the types of polar outlet boundaries are express-outlet, except for the inlet and outlet, the rest of the outer surfaces are set to wall. Then input the mass flow at the inlet of the anode, the operating temperature of the fuel cell and other conditions, the boundary conditions and physical properties parameters are shown in Table 3.

Table 3. Boundary conditions and physical parameters

Parameters	value
------------	-------

2.4 Mathematical model assumptions

The actual operation of a hydrogen fuel cell is influenced by many factors. To facilitate the simulation of hydrogen fuel cells, the following assumptions are made about the operating state of the fuel cell.

- 1) The hydrogen fuel cell is an isothermal system and does not take into account the effects of temperature changes on the fuel cell.
- 2) both reactants and products are ideal gases and incompressible.
- 3) there is no pressure gradient at the cathode and anode, only the diffusion of the gas is considered.
- 4) only the contact resistance between the diffusion layer of the gas and the bipolar plate is considered.
- 5) the reacting gas cannot pass through the proton exchange membrane
- 6) the gas diffusion layer, the catalytic layer and the proton exchange membrane are isotropic and the effect of anisotropy on the fuel cell is not considered
- 7) the electrochemical reaction takes place only in the catalytic layer;
- 8) The thermal conductivity used in the cell is a constant.

3. RESULTS AND DISCUSSION

3.1 Influence of the thickness of the gas diffusion layer on the fuel cell

3.1.1 Design of the thickness of the gas diffusion layer

The thicknesses of the gas diffusion layer are 0.18mm, 0.21mm and 0.24mm respectively. Under the same conditions, the effects of different thicknesses of the gas diffusion layer on the temperature distribution, water distribution and current density distribution are analysed.

3.1.2 Analysis of the effect of hydrogen and oxygen concentration and current density distribution

Figure 4 shows the mass change of hydrogen in the anode runner from the runner inlet to the outlet, where the horizontal coordinate is the distance from the runner outlet and the origin of the horizontal coordinate is the runner outlet. The curves from top to bottom are the hydrogen distribution curves for fuel cells with gas diffusion layer thickness of 0.21mm, 0.24mm and 0.27mm respectively. Fig. 4 shows that it can be seen that the hydrogen distribution curves of different gas diffusion layer thicknesses do not change significantly, and the three hydrogen mass distribution curves of different gas diffusion layer thicknesses basically overlap, with a small difference only at the position 0.01-0.06mm from the outlet.

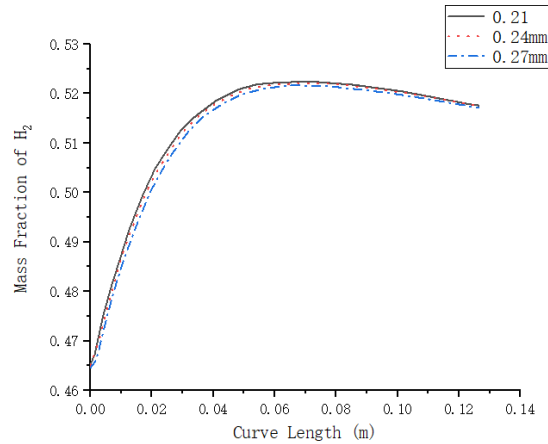

Fig. 4. Hydrogen distribution in the anode runner

Figure 5 shows the mass change of oxygen from the inlet direction to the outlet direction at the intersection of the cathode catalytic layer and the gas diffusion layer. The horizontal coordinate in the figure indicates the distance from the outlet, and the origin of the horizontal coordinate is the location of the outlet surface. The three curves in the figure from top to bottom represent the oxygen distribution curves for a hydrogen fuel cell with a gas diffusion layer thickness of 0.21mm, 0.24mm and 0.27mm respectively. The graphs show that the mass fraction of oxygen gradually decreases from the inlet to the outlet, and the mass fraction of oxygen at the same position decreases as the thickness of the gas diffusion layer increases, and the average oxygen content decreases by 1% for every 0.03mm increase in the thickness of the diffusion layer, indicating that the thicker the diffusion layer is, the more unfavourable the diffusion of oxygen is, and the oxygen has more resistance to enter the catalytic layer, due to the fact that the hydrogen fuel cell generates water at the cathode, which needs to After passing through the diffusion layer to discharge water out of the fuel cell, the thicker the gas diffusion layer, the more water is trapped in the diffusion layer, which will then reduce the porosity of the diffusion layer and thus inhibit the diffusion of oxygen.

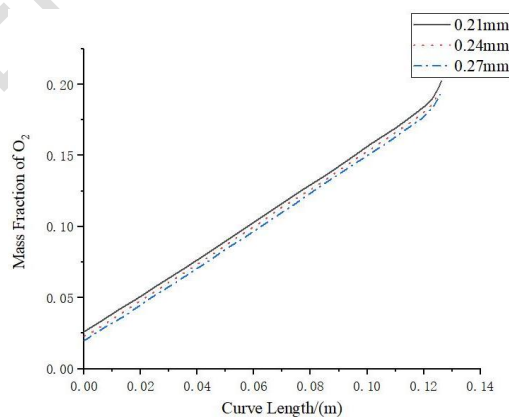

Fig. 5. Mass fraction distribution of oxygen at the cathodic CL-GDL intersection

Figure 6 shows the variation curve of the water mass distribution in the middle of the cathode gas diffusion layer (the origin of the horizontal coordinate is the outlet position and the inlet position at 0.125m). The curves from top to bottom in the figure represent the water mass distribution in the cathode diffusion layer for fuel cells with gas diffusion layer thicknesses of 0.27mm, 0.24mm and 0.21mm in that order. The graph shows that the thicker the gas diffusion layer, the larger the mass fraction of water in the gas diffusion layer. If the gas diffusion layer contains too much water, water

flooding may occur and the performance of the hydrogen fuel cell may be reduced. The thicker the gas diffusion layer, the greater the obstruction to oxygen diffusion. One important reason for this phenomenon is that the thicker the diffusion layer, the greater the accumulation of water in the diffusion layer, which is detrimental to oxygen diffusion.

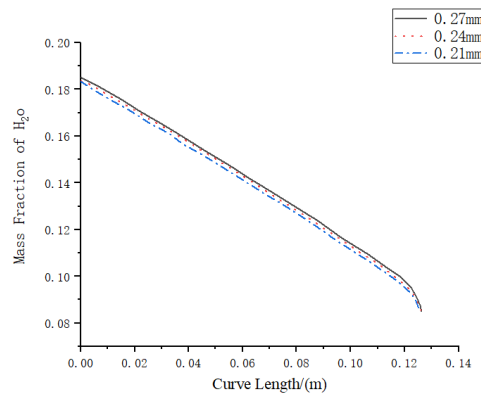

Fig. 6. Water mass distribution on the cathode diffusion layer

Figure 7 shows from left to right the current density distribution on the middle section of the fuel cell for 0.21mm, 0.24mm and 0.27mm gas diffusion layer thickness respectively, with increasing thickness of the gas diffusion layer, the current density of the fuel cell decreases and the performance decreases.

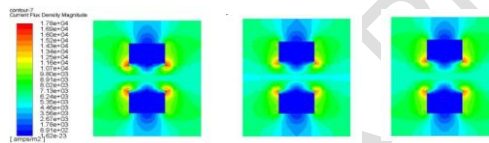

Fig. 7. Distribution of current density in the middle of different GDL thicknesses

Figure 8 shows that as the thickness of the gas diffusion layer increases, the higher current density at the exit location moves away from the exit location, causing the average current density at the exit location to decrease. Therefore it can be known that as the thickness of the diffusion layer increases, the more uneven the current density distribution on the proton exchange membrane, the greater the difference in current density at the inlet and outlet, making the fuel cell performance worse.

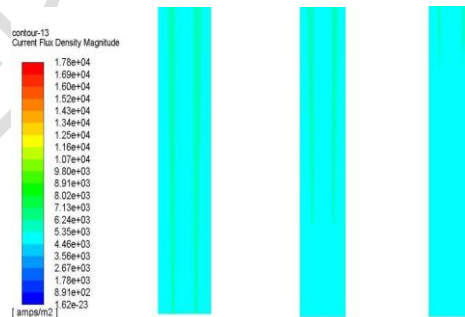

Fig. 8. Distribution of current density on the proton exchange membrane near the inlet position

3.2 Effects of catalytic layer thickness on hydrogen fuel cell performance

3.2.1 Design of the thickness of the Catalytic layer

The thicknesses of the gas diffusion layer were established as 0.18 mm, 0.21 mm and 0.24 mm, respectively. Under the same operating conditions, the effects of different thicknesses of the catalytic layer on the temperature distribution, water distribution and current density distribution were derived, and the preferred thickness of the gas diffusion layer was compared.

3.2.2 Analysis of the effects of oxygen concentration, water distribution and current density distribution

Figure 9 shows the distribution of the mass of oxygen in the cathode runner from inlet to outlet, the curves in this figure from top to bottom represent the distribution of oxygen in the cathode runner for fuel cells with catalytic layer thickness of 0.012mm, 0.015mm and 0.018mm respectively, the greater the thickness of the catalytic layer, the lower the mass fraction of oxygen in the runner, indicating an increase in the total amount of oxygen involved in the reaction. Figure 10 shows the distribution of water content in the cathode diffusion layer. The three curves in this figure represent the distribution of water in the cathode diffusion layer for fuel cells with catalytic layer thicknesses of 0.018 mm, 0.015 mm and 0.012 mm, respectively, from top to bottom, and show that the mass fraction of water content in the cathode diffusion layer increases as the catalytic layer thickness increases.

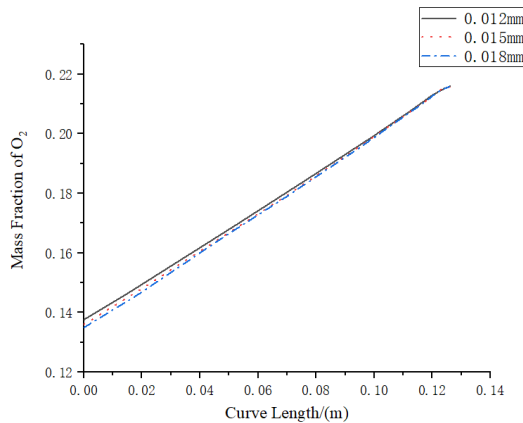

Fig. 9. Mass distribution of oxygen in the cathode runner

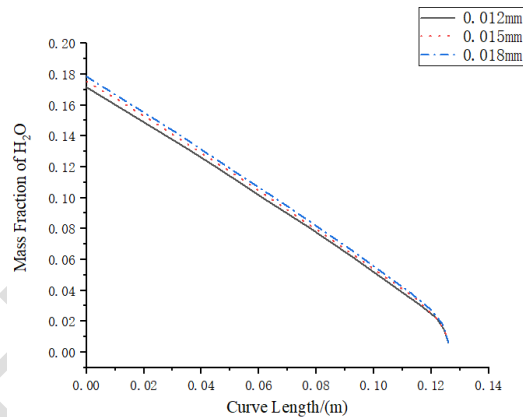

Fig. 10. Distribution of water content in the cathode diffusion layer

The water distribution on the lateral cross-section of the fuel cell (Figure 11) shows that the increase in the thickness of the catalytic layer increases the water content in the cathode runner, i.e. the amount of water generated by the fuel cell increases, indicating that the fuel cell with a catalytic layer thickness of 0.018 mm has a higher efficiency in terms of the reactions occurring and the hydrogen fuel cell is in better working condition for the same operating conditions.

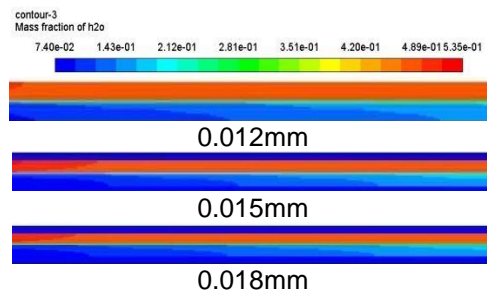

Fig. 11. Lateral water mass distribution

Figure 12 shows that when the catalytic layer thickness is 0.012mm, 0.015mm and 0.018mm respectively, the greater the catalytic layer thickness, the greater the current density of the hydrogen fuel cell and the better the cell performance will be obtained at the same output voltage.

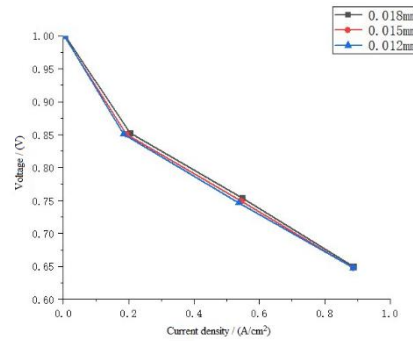

Fig. 12. Polarization curves of fuel cells with different catalytic layer thicknesses

Figure 13 shows the current density distribution on the middle cross section of the PEMFC model for hydrogen fuel cells with different catalytic layer thicknesses. It can be seen from the figure that the greater the thickness of the catalytic layer, the greater the current density at the cross section. The three curves in Figure 14 are, from top to bottom, the current density distribution on the fuel cell with 0.018mm, 0.015mm and 0.012mm catalytic layer thicknesses, with the horizontal coordinates The origin is the outlet position of the fuel cell model, and 0.125m from the outlet position is the inlet position of the fuel cell. Figure 14 shows that at the same horizontal coordinate, i.e. at the same position, the fuel cell with a catalytic layer thickness of 0.018mm has the highest current density value, followed by 0.015mm, while the fuel cell with a catalytic layer thickness of 0.012mm has the lowest current density. The simulation results show that an increase in catalytic layer thickness of 0.003mm increases the current density by an average of 1.75%, and the hydrogen fuel cell performance is relatively optimal when the catalytic layer thickness is 0.018mm.

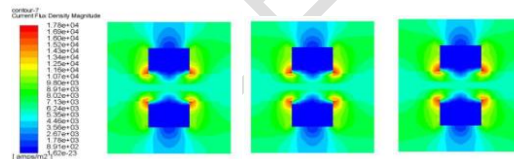

Fig. 13. Current density distribution at the intermediate section

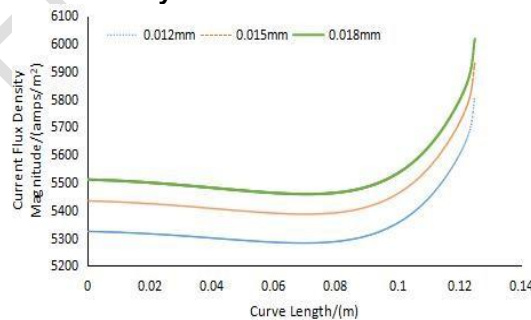

Fig. 14. Current density distribution on a proton exchange membrane

3.3 Effects of proton exchange membrane thickness on fuel cell performance

3.3.1 Thickness design of proton exchange membranes

Proton exchange membrane thicknesses of 0.1mm, 0.14mm and 0.178mm were established respectively. Under the same operating conditions, the temperature distribution, water distribution and current density distribution of the models with different thicknesses of proton exchange membranes were derived to compare the proton exchange membrane thicknesses that make the hydrogen fuel cell performance relatively good.

3.3.2 Analysis of the effects of hydrogen and oxygen concentration and current density

Figure 15 shows the distribution curves of hydrogen mass fraction from inlet to outlet position for hydrogen fuel cells with different proton exchange membrane thicknesses in the middle of the anode gas flow channel, where the origin of the horizontal coordinate is the outlet position of the model and the inlet position is at 0.125 m. The three curves in the figure represent from top to bottom the hydrogen mass distribution in the anode flow channel of the fuel cell. The simulation results show that as the thickness of the proton exchange membrane decreases, the mass fraction of hydrogen in the anode runner also decreases, indicating that the mass of hydrogen involved in the reaction increases, indicating that the decrease in the thickness of the proton exchange membrane is to some extent conducive to increasing the mass of hydrogen in the reaction.

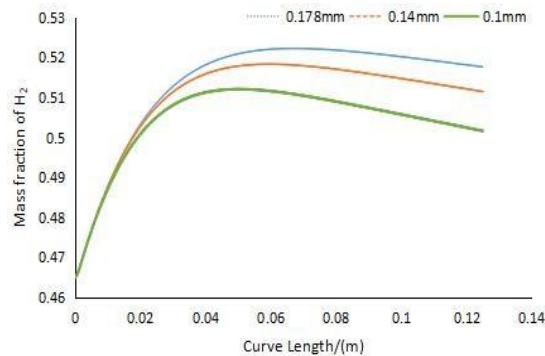

Fig. 15. Mass distribution curve of hydrogen in the anode runner

Figure 16 shows the distribution curves of the oxygen mass fraction from the inlet to the outlet position in the middle of the cathode gas flow channel for hydrogen fuel cells with different proton exchange membrane thicknesses. The three curves from top to bottom represent the oxygen mass distribution in the cathode flow channel for hydrogen fuel cells with proton exchange membrane thicknesses of 0.178mm, 0.14mm and 0.1mm respectively. The simulation results show that the larger the thickness of the proton exchange membrane, the larger the mass fraction of oxygen in the flow channel, indicating that the less oxygen content is involved in the reflection, making the fuel cell performance lower.

Figure 17 shows a graph of the polarization curves of fuel cells with different thicknesses of proton exchange membranes. The graph shows that the output voltage of the hydrogen fuel cell decreases at the same current density with the greater thickness of the proton exchange membrane, the reason being that as the thickness of the proton exchange membrane increases, the proton transfer efficiency is reduced to some extent, indicating that the performance of the fuel cell decreases with increasing thickness of the proton exchange membrane within a certain range.

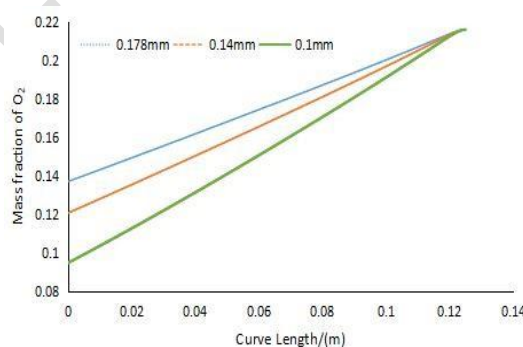

Fig. 16. Mass distribution curve of oxygen in the cathode runner

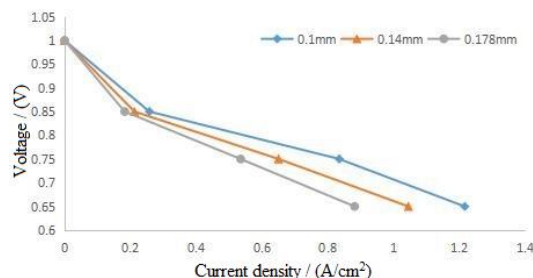

Fig. 17. Polarization curves of different proton exchange membranes

4. CONCLUSION

In this paper, the following results are obtained by setting up three sets of models for the thickness of the gas diffusion layer, the catalytic layer and the proton exchange membrane of the hydrogen fuel cell :

1) The greater the thickness of the diffusion layer, the lower the performance of the hydrogen fuel cell. The increase of the thickness of the gas diffusion layer will affect the diffusion of the reaction gas, especially the diffusion of cathode oxygen. The greater the thickness of the diffusion layer, the more water content in the cathode diffusion layer, which makes the porosity of the cathode diffusion layer decrease and increases the difficulty of oxygen passing through the diffusion layer. And the current density increases with the thickness of the diffusion layer, the more uneven the distribution on the proton exchange membrane. Among the three groups of fuel cells with different diffusion layer thicknesses in this simulation, the better performance is the 0.21mm thick fuel cell.

(2) In the three sets of fuel cells with different catalytic layer thicknesses in this simulation, the results show that an appropriate increase in catalytic layer thickness improves the performance of the hydrogen fuel cell. The increase in cathode product water content for larger catalytic layer thickness indicates an increase in the efficiency of the hydrogen fuel cell, and an increase in current density with increased catalytic layer thickness. Of the three sets of data, the fuel cell performance was better at a catalytic layer thickness of 0.018mm. In the data selected for this experiment, the performance of the hydrogen fuel cell became worse as the thickness of the proton exchange membrane increased.

3) When the thickness of the proton exchange membrane increases, the amount of gas involved in the reaction of the fuel cell decreases, yes the amount of water in the product decreases, the current density on the membrane decreases and less heat is generated, making the fuel cell performance decrease. In this simulation data, the thickness of the proton exchange membrane that makes the fuel cell performance better is 0.1mm.

COMPETING INTERESTS DISCLAIMER:

Authors have declared that no competing interests exist. The products used for this research are commonly and predominantly use products in our area of research and country. There is absolutely no conflict of interest between the authors and producers of the products because we do not intend to use these products as an avenue for any litigation but for the advancement of knowledge. Also, the research was not funded by the producing company rather it was funded by personal efforts of the authors.

REFERENCES

- [1] Mingyong Wang, Zhi Wang, Xuzhong Gong, Zhancheng Guo. The intensification technologies to water electrolysis for hydrogen production – A review. *Renewable and Sustainable Energy Reviews*. Volume 29,2014,Pages 573-588.
- [2] Seyed Ehsan Hosseini, Mazlan Abdul Wahid, Hydrogen production from renewable and sustainable energy resources:Promising green energy carrier for clean development,[J] *Renewable and Sustainable Energy Reviews*,2016,57, 850-866.
- [3] Schwengber C A,Alves H J ,Schaffner R A ,et al. Overview of glycerol reforming for hydrogen production[J]. *Renewable & Sustainable Energy Reviews*, 2016, 58 (Ma y) :259-266.
- [4] Tan Zetao. Study on H₂O Transport Mechanism in Gas Diffusion Layer of Proton Exchange Membrane Fuel Cell [D]. Beijing Jiaotong University, 2015.

- [5] Chang Yingjie. Dynamic modeling and performance simulation analysis of proton exchange membrane fuel cells [D]. Chongqing University of Technology, 2017. [4] Huang Hao. Durability of membrane electrodes in proton exchange membrane fuel cells [D]. East China University of Technology University, 2018.
- [6] Rui Jiao YU, Hang GUO, Fang YE, Study on Transmission Coefficients Anisotropy of Gas Diffusion Layer in a Proton Exchange Membrane Fuel Cell, *Electrochimica Acta*,2022,140163.
- [7] Gaojian Chen, Qian Xu, Jin Xuan, Jianguo Liu, Qian Fu, Weidong Shi, Huaneng Su, Lei Xing, Numerical study of inhomogeneous deformation of gas diffusion layers on proton exchange membrane fuel cells performance,*Journal of Energy Storage*,Volume 44, Part B,2021,103486.
- [8] Prince Abraham B, Kalidasa Murugavel K, Influence of Catalyst Layer and Gas Diffusion Layer Porosity in Proton Exchange Membrane Fuel Cell Performance, *Electrochimica Acta*, Volume 389,2021,138793.
- [9] Zhiming Bao, Yanan Li, Xia Zhou, Fei Gao, Qing Du, Kui Jiao, Transport properties of gas diffusion layer of proton exchange membrane fuel cells: Effects of compression, *International Journal of Heat and Mass Transfer*, Volume 178,2021,121608.
- [10] Like Yue, Shixue Wang, Takuto Araki, Yoshio Utaka, Yulin Wang, Effect of water distribution in gas diffusion layer on proton exchange membrane fuel cell performance, *International Journal of Hydrogen Energy*, Volume 46, Issue 3,2021,Pages 2969-2977.
- [11] Klingele M, Breitwieser M, Zengerle R, Thiele S. Direct deposition of proton exchange membranes enabling high performance hydrogen fuel cells[J]. *Mater Chem.A*,2015,3:11239–11245.
- [12] Cappadonia, Erning JW, Aki SMS, et al. Conductance of Nafion117 membrane as a function of temperature and water content[J].*Solid State Ionics*,1995,77 : 65-69.
- [13] Wang L,Attila H,Zhou TH,et al.A parametric study of PEM fuel cell performance[J].*International Journal of Hydrogen Energy*,2003,28:1263-1272.
- [14] Murata S,Imanihil M,Hasegawa S,et al.Vertically aligned carbon nanotube electrodes for high current density operating proton exchange membrane fuel cells[J].*Journal of Power Sources*,2014,253(5):104.
- [15] Moreira J,Oeampo AL,Sebastian PJ,et al.Influence of the hydrophobic material content in the gas diffusion electrodes on the performance of a PEM fuel cell[J].*International Journal of Hydrogen Energy*,2003,28:625-627.