

Original Research Article

Valoblock: A Thermally Resistant and Structurally Design and Enhanced Block

Abstract—Concrete blocks or hollow blocks are widely used in the community for building infrastructure, functioning as a necessity for shelter. However, the Philippines is also known to experience various natural disasters such as earthquakes and typhoons. Relative humidity is also high in the country causing it to have higher temperatures compared to different nations. Given that, the natural disasters and the high relative humidity found in the country contribute to the continuous damage on the infrastructure and lesser thermal properties. In response, the researchers have decided to create an alternative design of a hollow block with improved thermal properties and structural capacity. The researchers have derived and sketched a feasible design of a hollow block with high thermal resistance using Fusion 360. Three hollow block designs namely Design A, Design B, and Design C were then conducted of uniform simulations in the form of a non-linear stress test using Fusion 360. Statistical analysis of the listed factors pointing to safety and durability was also done. The study has attained results where it has been determined each design has certain traits that makes it more preferable than the classic design. In the case of Design B and C, they hold a degree of improvement in terms of its reduced stress and strands. This leads to the idea that Design A can be an appropriate substitution to that of the commonly used design, which would greatly alleviate the common problems that Filipino engineers face daily.

Keywords - hollow block, thermal properties, non-linear stress test, Fusion 360, structural capacity

I. INTRODUCTION

Concrete blocks are widely used for construction, there are multiple types that are used for different purposes. Houses nowadays mostly use concrete or are made from hollow blocks, as advancements and developments in the country continue to thrive with modernity, this has been used as a necessity for building shelter. Hollow blocks have been found to have better uniform quality, longer durability, faster speed of construction, and lower labor requirements. In view of these advantages, hollow blocks are increasingly used in different construction activities. These activities include, but not limited to, load bearing walls, interior walls, panel walls, retaining walls and compound walls (Elgaali, E., Elchalakni, E. 2013). There have been many different researches about altering the composition of hallowblocks or the coalescence of multiple materials with it. Rather than

using purely conventional concrete mixture, there have also been studies that utilize recycled water plastic bottles in concrete blocks. Concrete hollow blocks made with coarse aggregate and recycled water termed as “green blocks” have also been conducted by Elgaali, E. and Elchalakni, E. (2013). These are only some of the different creative ways that provide help for the construction and the community at the same time.

According to the Eurasian – Philippines Sea plate collisions, the Philippine islands and the adjacent areas are tectonically adjacent. The Philippines lies along the Pacific Ring of Fire, causing the country to have multiple and frequent seismic or volcanic activities. Earthquakes of smaller magnitude occur regularly due to the meeting of major tectonic plates in the region. The National Earthquake Information Center has reported that around 20,000 earthquakes occur around the globe every year, and there are about 55 approximately per day. Agencies in the Philippines such as the Philippine Institute of Volcanology and Seismology (PHIVOLCS) mainly focus on seismic and volcanic activities that occur in the country. In the past years, there have been notable earthquakes with large intensities and magnitudes that have severely damaged certain areas. According to the Philippine Statistics Authority (2020), the damages that incurred to natural extreme events and disasters amounted to Php 463 billion from 2010 to 2019. Although earthquakes are not fully responsible for all the destruction, it still contributes a huge amount to the destruction of infrastructure. Back in 2013, a magnitude 7.2 earthquake struck Bohol and according to the National Disaster Risk Reduction and Management Council, around 222 were reported dead while 796 people were injured. Tens and thousands of structures were damaged by the earthquake, it has also destroyed notable and historical infrastructures in Bohol and Cebu. Buildings and houses being shaken by the earthquake has caused debris to potentially trap and kill the people. As mentioned, hollow blocks are the main component used in the construction of the buildings, and questions are being raised about how these can be created to be highly resistant to earthquakes. Therefore, deformation properties and other seismic behaviors of concrete hollow block masonry can be further

Studied to help reduce the damage and danger towards the lives of people when experiencing earthquakes.

Relative humidity is high in the Philippines, and a high amount of moisture or vapor in the air makes the hot temperature feel hotter. This is similar in many aspects to the climate of the countries of Central America. In the hot dry season of the country from March to May, the hottest temperature recorded in the Philippines was about 42 degrees Celsius in Tuguegarao, Cagayan. This can cause extreme heat especially in enclosed spaces of infrastructure. Concrete hollow blocks also have various thermal properties. For concrete, it contains three thermal properties, which are specific heat, thermal conductivity, and coefficient of thermal expansion (Lane, 2006). When pores are introduced into bricks their thermal conductivities are reduced. This can be done by either microporosities, like the closed pores created by pore making additives before firing of the bricks, or by introducing perforations extending through the brick like in the case of vertically perforated brick (Kormann, M. 2008). The thermal properties of concrete hollow blocks can also be altered to help comfort with the people that have houses built by hollow blocks. There have been multiple studies that have analyzed the thermal properties of concrete hollow blocks and they were able to provide alternated designs in order to improve the thermal properties. These self-insulation properties that can be integrated in hollow blocks can provide help with the use of less resources and more efficient effects. Given these related problems such as the destruction of infrastructure due to earthquakes and the continuous high temperature found in the country, the researchers have decided to create a custom design of a hollow block with the integration of a thermal resistant design in order to provide better strength and thermal properties compared to hollow blocks used nowadays.

II. RELATED WORKS

A. Hollow Block

One of the basic requirements of a human being is shelter, since in the past, people have been living from caves to wooden houses and so on. The materials that people use for building shelter eventually start to improve and develop. Nowadays, concrete hollow blocks are commonly used for the construction of infrastructure. Buildings, factories, residential buildings are built with hollow blocks for multiple reasons. One is that they are cheap, lightweight, and have the free flow of ventilation. Hollow concrete blocks are found out to have multiple advantages, they are sound control, small dead load, resistance to fire, adequate strength, superior thermal insulation, economy, highly durable, environmentally eco-friendly, reduction in mortar consumption, fast and easier construction system, and better architectural features (Harshit, V. 2015). A concrete hollow block is primarily used as a building material in the construction of walls, it is often called a concrete masonry unit (CMU). One of the main benefits for using concrete hollow blocks is that it is economical in design of a sub-structure due to the reduction of loads. They are simple and easy to use. One concrete hollow block replaces about

five traditional bricks, thus reducing the construction cost. It also decreases the cost of the structural design due to its lightweight, which shrinks the size of structural members of both the foundation and superstructure. The construction also requires less mortar and saves labor hours. The prices of hollow blocks in the Philippines vary over the material and the size of it.

a.) Hollow Block Design

A concrete masonry unit (CMU) is a standard size of rectangular block used in building construction; they are one of the most versatile building products available due to a wide variety of appearances that can be achieved when using them. As mentioned, concrete blocks may be produced with hollow centers to reduce weight, improve insulation, and provide an interconnected void into which concrete can be poured to solidify the entire wall after it is being built. The typical size referred to their thickness of a block is 4 inch – 6 inch – 8 inch – to 12 inch. In the Philippines the standard product size is about 40 centimeters in length, 20 centimeters in height, 10 and 15 centimeters in depth (Humanitarian Shelter Working Group, 2014) There have been multiple designs created for the hollow blocks, it can be either integrating a different material into the hollow block or by changing the formations and positions to produce a much durable and effective structural composition.

b.) Disadvantages of the Classic Hollow Block

The traditional hollow block contains multiple flaws making it susceptible to destruction and cause of many accidents. One of the main disadvantages of a hollow block is that it contains a poor bearing capacity as the average mass of wall decoration materials is decreased, and the load-bearing capacity is often reduced. Load bearing wall is one of the oldest structural systems. Man has laid one stone upon another and built walls to support the roof or floor. This system was then replaced by frame structures for economy, as the load bearing walls being thick require a large quantity of materials (Maroliya, M. 2012). From a study conducted by Maroliya, M. (2012) titled Load Carrying Capacity of Hollow Concrete Masonry Wall, the objective of their study was to identify the load bearing capacity of the hollow concrete blocks when used in the construction of walls. The crack pattern at the initial and final failure was also minded. The hollow concrete blocks were tested in the compression testing machine, and several blocks were tested and by knowing the load carrying capacity of a single unit, the researchers constructed different types of structure. The study obtained results stating that the hollow concrete block of sizes 400 x 200 x 200 mm gave the average compressive strength of about 11.25 kg/cm². It was then concluded that the strength of walls constructed with hollow concrete blocks give less strength as compared to brick masonry.

Another issue regarding the use of hollow blocks is the appearance of a common engineering defect, cracks. Cracks

contain a number of negative effects on infrastructures, it can cause the heat bridge effect weakening the wall insulation and thermal insulation properties. The appearance of cracks reduces the durability, applicability, bearing capacity, and seismic performance of buildings. When the cracks are serious to a certain extent, it will affect the structural safety of buildings and affect people's normal life (Khankhaje et al., 2017). From a study conducted by Luan, H. et al., (2017), titled the Cause Analysis and Control Measures of Cracks in Filling Wall of Reinforced Concrete Structure, the study has focused about the crack problem of the filler wall in reinforced concrete structure appearing more and more frequently with its wide application. The researchers analyzed the causes of the cracks in the block filler wall in the frame of the reinforced concrete structure from the aspects of the external environmental factors and intrinsic material factors. As their study analyzed the concrete causes of cracks in the frame filled with walls of steel reinforced concrete structures, they have identified that the cracks are caused by temperature variation, uneven settlement of foundation, influence of humidity and the strength of mortar.

c.) Structural Significance

The Philippines is ranked as third among all the countries with the highest risks worldwide according to the World Risk Report in 2018. At least 60% of the Philippines' total land area is exposed to multiple hazards and 74% of the population is susceptible to their impact (Global Facility for Disaster Reduction and Recovery, 2018). All of these are most likely due to the location and geographical context as the risk involving coastal hazards such as typhoons, storm surges, and rising sea levels is high. The islands of the country are also located within the Ring of Fire between the Eurasian and Pacific tectonic plates; thus, earthquakes and volcanoes are posing serious risk to the exposure of natural hazards. Since the 1990's, the Philippines has been affected by 565 disaster events which have caused an estimated \$US 23 billion in damages (Jha, et al., 2018). With the fact that we live in an area wherein calamities and natural disasters occur frequently, these give different factors that deteriorate the structural integrity of infrastructure.

One factor known is temperature. According to a study conducted by Luan, et al (2017), the outer surface of the wall or the top of the wall is prone to irregular cracks. The researchers have stated that the linear expansion of the two significant differences between the characteristics of the wall and the top of the junction, and the floor plate position in the internal and external temperature control Prone to pressure difference, with the constant increase of internal and external pressure difference, the building will be a fault or cracks. Especially in the summer, large indoor and outdoor temperature differences produce a larger outward expansion of the deformation to the floor, which makes the wall produce lateral pressure. The wall was cut so that the wall from both ends of the central inclined oblique cracks. Material moisture content of the wall has risen because of

rainfall and air humidity. Aerated concrete block is the most obvious wall material with humidity changes in the material. Once the block of water swells, it will have its corresponding internal anti-expansion capacity. The cracks are known to contribute to the deteriorating factors on the structural integrity of infrastructure. These environmental factors are like what the Philippines experiences during its hot dry summer season between March and May. According to the Philippine Atmospheric, Geophysical and Astronomical Services Administration (PAGASA), a scorching 52 degrees Celsius was recorded on the Heat Index in Northern Luzon last April 9, 2019 and in Pasay City, Metro Manila, it recorded about 42 degrees on the same day. The Philippines is located above the equator, meaning that our country experiences hotter temperatures. These environmental factors such as the temperature or humidity in our country basically make the structural integrity of buildings prone to cracks, hence destruction.

There are also physical forces which act on the buildings, they are hydrostatic loads, hydrodynamic loads, and impact loads. These loads can be exacerbated by the effects of water scouring soil from around and even below the foundation. According to a study conducted by Retnan, et al. (2012), the hydrostatic loads are both lateral (pressures) and vertical (buoyant) in nature. The lateral forces result from differences in interior and exterior water surface elevations. As the floodwaters rise, the higher water on the exterior of the building acts inward against the walls of the building. Sufficient lateral pressures may cause permanent deflections and damage to structural elements within the building. When buoyant forces associated with flood exceed the weight of the building components and the connections to the foundation system, it can cause the structure to float from its foundation. The water flowing around the building during a flood creates hydrodynamic loads on the structure (Retnan, et al. 2012). As mentioned, the Philippines experiences multiple typhoons and floods due to its geographical location. This provides an insight that there can be changes done to the hollow block design to alleviate the damages done by these typhoons to the structural integrity of infrastructure.

B. Thermal Properties of Hollow Block

Thermal properties are associated by a material-dependent response when heat is supplied to a solid body, a liquid, or a gas. This response might be a temperature increase, a phase transition, a change of length or volume, an initiation of a chemical reaction or the change of some other physical or chemical quantity (Buck, W. et al. 2011). For concrete, it contains three thermal properties, which are specific heat, thermal conductivity, and coefficient of thermal expansion (Lane, 2006). When pores are introduced into bricks their thermal conductivities are reduced. This can be done by either microporosities, like the closed pores created by pore making additives before firing of the bricks, or by introducing perforations extending through the brick like in the case of vertically perforated

brick (Kormann, M. 2008). This is why hollow bricks are hollow because rather than making it lightweight and economic material, it also improves thermal performance. Energy and environment are two major challenges faced by mankind and building energy consumption accounts for more than 40% of the social energy consumption (Zhao, et al. 2012). Building energy conservation contains a great significance on the energy crisis alleviation and environment protection. It is vital to create a high comfort level and decrease building energy consumption by improving thermal performance of a building's external envelope, or in other words the wall body. Thus, there have also been multiple studies that focus on improving the thermal performance of the hollow blocks by altering the design and integrating multiple materials in it.

The studies related that are mentioned provide insight towards the design that the researchers will be using. The methodologies utilized by various studies will be compared and analyzed to exert the most efficient method for the study. Hence, the researchers have decided that using simulation applications, similar results in real life simulations will also be seen. Equations, computations, and alternatives will be further done by the researchers in the following chapters.

III. METHODOLOGY

A. Thermal Conductivity Coefficient Formulation

a.) Variables and Constants

Nomenclature

- C - specific heat at constant pressure
- g - gravitational acceleration
- k - thermal conductivity
- L - block width
- Nu - nusselt number, $Nu = \frac{Q_{actual}}{Q_{conduction}}$
- Q - conduction in air-filled non-partial enclosure
- q'' - heat flux
- Pr - prandtl number

Greek symbols

- α - thermal diffusivity
- β - coefficient of thermal expansion
- μ - dynamic viscosity
- ν - kinematic viscosity
- ρ - density

- o - outer
- i - inner

b.) Conduction Heat Transfer

$$(\partial^2 T)/(\partial x^2) + (\partial^2 T)/(\partial y^2) = 0 \quad (1)$$

$$T = T_1 \text{ at } x = 0, T = T_o \text{ at } x = L \quad (2)$$

$$\partial T/\partial x = 0 \text{ at } y = 0, (\partial^2 T)/(\partial x^2) = 0 \text{ at } y = w \quad (3)$$

$$-K \partial T/\partial x = q'' \text{ at } y = L_1 \text{ and at } x = L_1 + L_2 \text{ for } w_1 < y < w_1 + w_2 \quad (4)$$

$$-K \partial T/\partial x = q'' \text{ at } y = L_1 \text{ and at } x = L_1 + L_2 \text{ for } L_1 < x < L_1 + L_2 \quad (5)$$

Where $L_1 = (L_1 + L_2 + L_1)$, $w = (w_1 + w_2 + w_1)$

q''s.x and q''s.y are the convection heat transfer flux at the interface in both x and y directions (Fig. 1 A).

c.) Convection Heat Transfer

$$\partial u/\partial x + \partial v/\partial y = 0 \quad (6)$$

$$u \partial u/\partial x + v \partial v/\partial y = -1/\rho \partial p/\partial x + \nu((\partial^2 u)/(\partial x^2) + (\partial^2 u)/(\partial y^2)) \quad (7)$$

$$u \partial u/\partial x + v \partial v/\partial y = \nu((\partial^2 u)/(\partial x^2) + (\partial^2 u)/(\partial y^2)) - g\beta(T - T_\infty) \quad (8)$$

$$u \partial u/\partial x + v \partial v/\partial y = k/\rho C ((\partial^2 u)/(\partial x^2) + (\partial^2 u)/(\partial y^2)) \quad (9)$$

In this case in order to preserve a thoracically accurate constant that reflects the heat transfer in both lateral and horizontal matters, A no slip condition would be applied at the interior surfaces.

$$u = v = 0 \quad (10)$$

Progression of temperature and warmth transition is considered at internal surfaces. Be that as it may, temperatures are obscure and found through the iterative arrangement.

$$q''_{conduction} = q''_{convection} \quad (11)$$

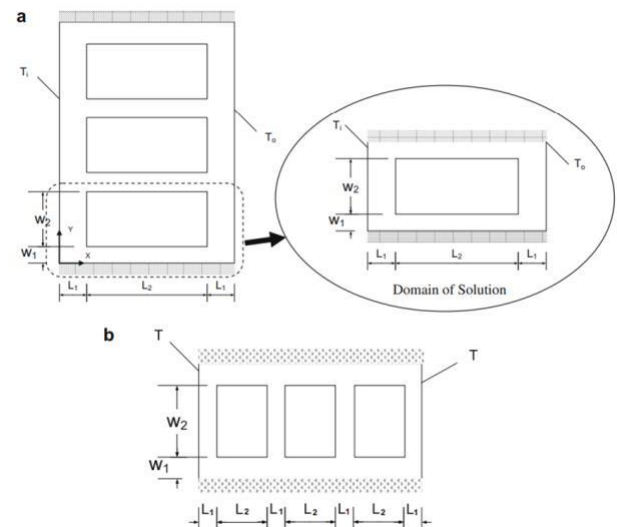

Figure 2. A typical hollow block with (a) single cavity and (b) three cavities

B. Creation and Sketching of Design

With respect to the initial design of a typical hollow block (Figure 1. A), design would be created that involves a locking mechanism to ensure security between each block. Three Designs would be made that would implement the general dimension that is observed in most hollow blocks (390mm, 140mm, 190mm).

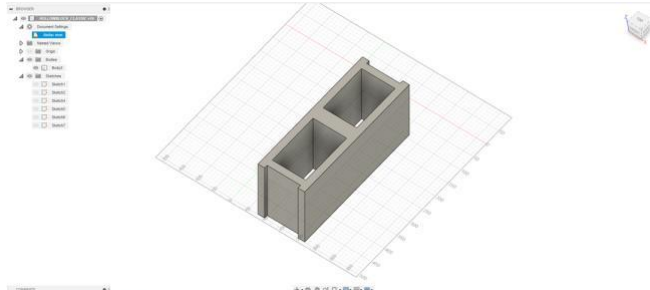

Figure 3. A The Classic Hollow Block Design

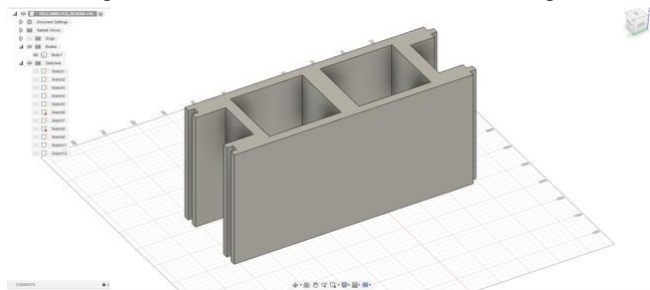

Figure 3.B The Initial Proposed Design (Design A)

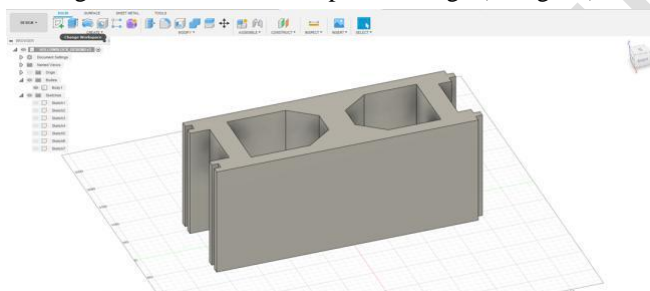

Figure 3.C The Second Proposed Design (Design B)

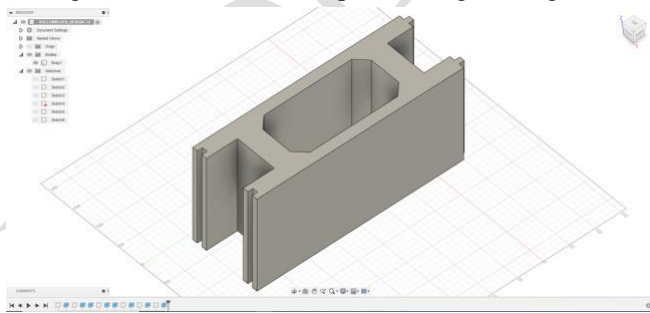

Figure 3.D The Third Proposed Design (Design C)

C. Parameters for Implementation

After thorough deliberation, the need to ensure that the simulation and analysis of the structural aptitude of the theoretical design would rely on the parameters being

utilized to mimic that of real-world usage of these designs. A fixed or uniform property would be utilized.

a.) Material Properties

The properties of the material that would be subjected in a non-linear stress test would be:

- Linear properties:
 - Density: 2000 kg/m³
 - Young's modulus: 23,000 MPa.
 - Poisson's ratio: 0.21 .MPa.
 - Shear Modulus: 7.800 MPa
 - Density: 2.300 g/cm³
 - Damping Coefficient: 0.05
 - Density: 2.300 g/cm³.
- Nonlinear properties for Willam and Warnke model:
 - Ultimate uniaxial compressive strength, $f_c = 30$ MPa.
 - Ultimate uniaxial tensile strength, $f_t = 2.100$ MPa.
 - Shear transfer coefficient for an open crack: 0.3.
 - Shear transfer coefficient for a closed crack: 0.7.
- Nonlinear properties for Drucker–Prager material model:
 - Angle of internal friction: 25°.
 - Cohesion value [1,14,15]: $c =$
 - $f_c \cdot (1 - \sin \Phi) / 2 \cos \Phi = 15.92$ MPa.**
 - Dilatancy angle: 5°.

Thermo physical properties.

Material	Density (kg/m ³)	Specific-heat Cp (J/kg K)	Thermal conductivity (W/m K)	Coefficient of thermal expansion (K ⁻¹)	Viscosity (kg/m s)
Air	1.225	1006.2	0.0242	3.30E-03	1.79E-05
Concrete	2000	840	0.95		

Figure 4. A. Thermo Physical Properties of Concrete

D. Simulation

a.) Force and Boundaries

In order to determine the structural durability of the hollow block design, a uniform pressure should be exerted to determine the extent of damage and the feasibility of adopting said design. A uniform pressure of 16 MPa would be applied on the topside of each hollow block design (Figure 5. A) . Another constraining would be added to mimic that of its realistic utilization. This constraint would be in the form of limited displacement or seized displacement in the X, Y, Z axis. This replicates its position in a structural formation with its constituent being hollow blocks.

IV. RESULTS AND DISCUSSION

A. Thermal Resistance Correlation

With the intended application of the thermophysical properties of the material and the implications of the natural convection in enclosures with conducting multi partitions and side walls, the application of standard boundary conditions of vertical isothermal surfaces and adiabatic horizontal ones within the cavity. In order to match the given conditions, the usage of Nu was integrated into the formulation of the heat transfer flux for the convection in each cavity with respect to the conduction of heat in the walls of the design. With that said, it can also be observed that it is known that the heat transfer coefficient is dependent on the width of the cavity, fluid properties as well as the temperature difference between the inner vertical surfaces. This heat transfer rate (given in terms of Rayleigh number, Ra) can be decreased either by reducing the width of the cavity or by decreasing the temperature difference between cavity vertical walls. Utilizing the single cavity as a basis for determining the difference between the movement or the velocity at which the fluid or air travels in the cavity can be determined. This helps determine the correlation or the observable difference between the presence of different cavities with equal sizes. Results has indicated that increasing the number of cavities to two, and then three cavities keeping the total width constant, resulted in decrease of the maximum air velocity within the cavities by 30.34% and 40.56%, respectively, indicating a significant decrease in the convective heat transfer coefficient. It can also be observed in Figure 6. B each respective R-value, which corresponds to the a decrease in heat transfer. This indicates that a positive relation can be formed between the number of cavities and improving thermal resistance. It can also be said that size or dimensions play a significant role in this matter. This suggests that the size of the cavity with respect to the dimensions for each design would play a significant role in hindering the movement or transfer of heat in the X and Y plane. In figure 6. A, it can be observed that there exists a high gradient along the vicinity of the vertical surfaces. It can be observed that the temperature of the outer layer of the design is more constant. This indicates that the material concrete has a relatively even dispersion of heat. With the application of cavities, this provides a barrier that prevents an equal dispersion but rather creates a gradient as observed in Figure 6. A. A single cavity has a limited effect on hindering the dispersion of the heat to the other side, but it is blatantly clear that 2 cavities greatly hinders the movement of heat. It can also be said that the size of each cavity has an equally drastic effect on determining the feasible design that would implore a more

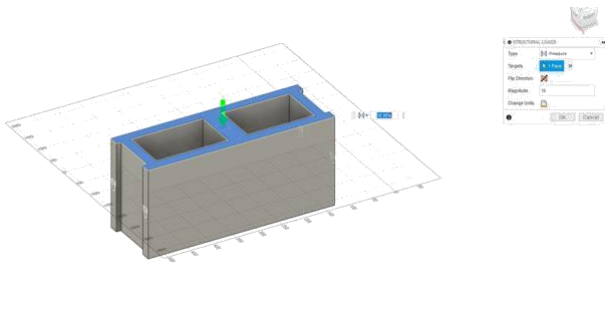

Figure 5. A The uniform application of pressure on the topside of the Hollow Block

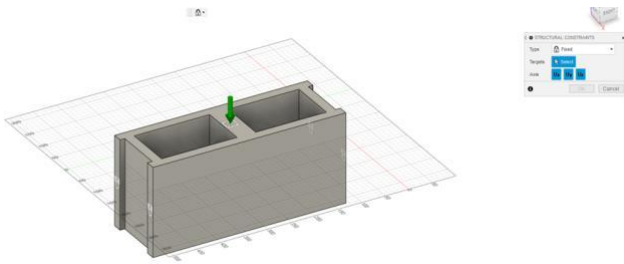

Figure 5. B The application of a fixed constraint in the displacement of X, Y,Z axis

b.) Non-linear Static Stress

The said designs would be subjected to non-linear Static Stress Simulation to determine the structural capacity of these designs at various loads, which limits to a load of 16 MPa. This is used to determine the possible point of structural changes that would point to degradation in structural integrity. This would indicate an estimation of a maximum load that can be derived from observable data. With that said, this simulation would depict 10 steps, which comprises 10 instances with increasing pressure being applied on the top side of the hollow brick.

E. Statistical Analysis

a.) ANOVA

Utilizing the data that can be subjected to this form of analysis that has a relation to the structural strength of the design, it would help determine the possibility of implementing the created designs. Said factors would be: Safety Factor (Minimum), Von Mises Stress (Maximum), and Strain (Maximum). This study would opt to utilize a confidence interval of 95% or a Significance Level of 0.05.

$$\text{Null Hypothesis: } H_0 = \mu_i < \mu_o$$

$$\text{Alternative Hypothesis: } H_A = \mu_i > \mu_o$$

thermally

resistant

effect.

B. Non-Linear Stress Test

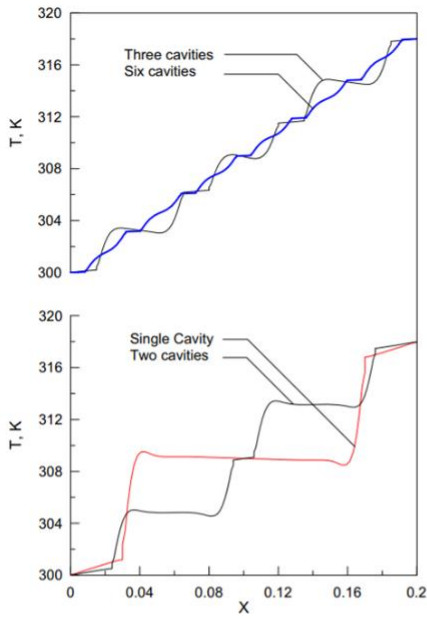

Figure 6. A Temperature distribution at the mid Y-plane for: (a) single cavity, two cavities, and (b) three cavities, six cavities

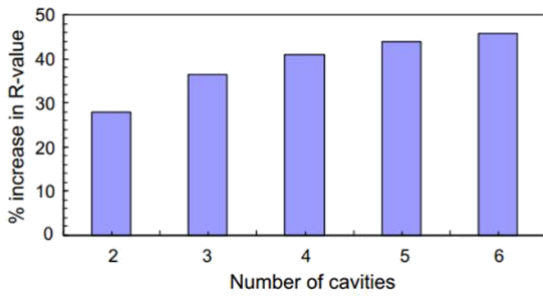

Figure 6. B . Percentage increase in the R-value with number of cavities.

	Classic	Design A
16 MPa		
14 MPa		
12 MPa		
10 MPa		
0 MPa		

Table 1. A. Simulations of the Classic Design and Design A with their corresponding Safety Factor Indicator

	Design B	Design C
16 MPa		
14 MPa		
12 MPa		

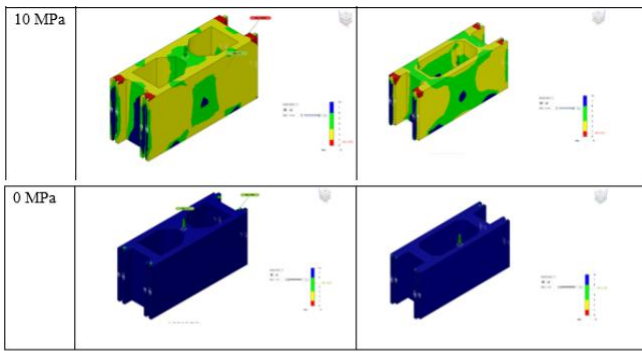

TABLE 1. B. Simulations of the Design B and Design C with their corresponding Safety Factor Indicator

	Volume(mm ³)	Weight (Kg)	Von Mises Stress (Max) 16 MPa	Von Mises Stress (Max) 14 MPa	Von Mises Stress (Max) 12 MPa	Von Mises Stress (Max) 10 MPa
Classic	4.636x10 ⁶	10.65	145.8 MPa	127.7 MPa	109.5 MPa	91.25 MPa
Design A	4.260x10 ⁶	9.79167	86.18 MPa	75.41 MPa	64.64 MPa	53.87 MPa
Design B	5.586x10 ⁶	12.84	102.3 MPa	89.53 MPa	64.64 MPa	63.98 MPa
Design C	5.130x10 ⁶	11.79	92.19 MPa	80.67 MPa	69.14 MPa	57.62 MPa

Table 1.C Results for Von Mises Stress

	Volume(mm ³)	Weight (Kg)	Strain (Max) 16 MPa	Strain (Max) 14 MPa	Strain (Max) 12 MPa	Strain (Max) 10 MPa
Classic	4.636x10 ⁶	10.65	.00846 mm	.00509 mm	.00598 mm	.00537 mm
Design A	4.260x10 ⁶	9.79167	.00741 mm	.00445 mm	.00524 mm	.00470 mm
Design B	5.586x10 ⁶	12.84	.00635 mm	.00382 mm	.00449 mm	.00403 mm
Design C	5.130x10 ⁶	11.79	.00530 mm	.00318 mm	.00375 mm	.00336 mm

Table 1.D Results for Strain

	Volume(mm ³)	Weight (Kg)	Safety Factor (Max) 16 MPa	Safety Factor (Max) 14 MPa	Safety Factor (Max) 12 MPa	Safety Factor (Max) 10 MPa
Classic	4.636x10 ⁶	10.65	.2057	.3288	.2932	.3254
Design A	4.260x10 ⁶	9.79167	.2350	.3481	.3351	.3719
Design B	5.586x10 ⁶	12.84	.2741	.3978	.3908	.4339
Design C	5.130x10 ⁶	11.79	.2057	.4641	.4689	.5206

Table 1. E Results for Safety Factor

a.) Von Misses

The Von Mises stress is a value used to determine if a given material will yield or fracture. ... The von Mises yield criterion states that if the von Mises stress of a material under load is equal or greater than the yield limit of the same material under simple tension then the material will yield. This would aid in indicating the possible designs that would be able to withstand or have a better yield under uniform pressure. As observed in Table 2. A, Design A, Design B, and Design C experiences less than the average

stress experienced by the Classic Design in comparison, which indicates a better performance in terms of the presence of a uniform pressure. Although, there is evidence pointing to the significant difference of means between the Designs A, B, and C to the classic design. This is proven by the fact that the significance of each design to the classic design is less than 0.05. There is no definite manner to determine which design is better unless compared in different factors.

Dependent Variable	(I)	(J)	Multiple Comparisons			95% Confidence Interval		
			Mean Difference (I-J)	Std. Error	Sig.	Lower Bound	Upper Bound	
VonMises	Tukey HSD	Classic	Design A	48.53750*	12.87453	.012	10.3143	86.7607
		Design B	38.45000*	12.87453	.049	.2268	76.6732	
		Design C	43.65750*	12.87453	.024	5.4343	81.8807	
		Design A	Classic	-48.53750*	12.87453	.012	-86.7607	-10.3143
		Design B	-10.08750	12.87453	.860	-48.3107	28.1357	
		Design C	-4.88000	12.87453	.981	-43.1032	33.3432	
		Design B	Classic	-38.45000*	12.87453	.049	-76.6732	-.2268
		Design A	10.08750	12.87453	.860	-28.1357	48.3107	
		Design C	5.20750	12.87453	.977	-33.0157	43.4307	
		Design C	Classic	-43.65750*	12.87453	.024	-81.8807	-5.4343
		Design A	4.88000	12.87453	.981	-33.3432	43.1032	
		Design B	-5.20750	12.87453	.977	-43.4307	33.0157	

Table 2. A Multiple Comparison of Von Mises Stress (Turkey HSD) Between groups.

b.) Strain

Strain refers to any form of deformation in the X, Y, and Z, brought on by the existence of stress. With that said, In table 3. A, it can be observed that Designs A and C experience a less significant strain with respect to the X, Y, and Z axis. This can be supported by their significance to each indicating an equal of means and their significance of being less than 0.05 with respect to Designs C and Classic Design. It can be assumed that these Designs Exhibits a sturdier structural design.

Strain	Tukey HSD	Classic	Design A	.00274400*	.0007251	.012	.0005910	.0048970
		Design B	.00201525	.0007251	.069	-.0001377	.0041682	
		Design C	.00251750*	.0007251	.021	.0003645	.0046705	
		Design A	Classic	-.00274400*	.0007251	.012	-.0048970	-.0005910
		Design B	-.00072875	.0007251	.750	-.0028817	.0014242	
		Design C	-.00022650	.0007251	.989	-.0023795	.0019265	
		Design B	Classic	-.00201525	.0007251	.069	-.0041682	.0001377
		Design A	.00072875	.0007251	.750	-.0014242	.0028817	
		Design C	.00050225	.0007251	.898	-.0016507	.0026552	
		Design C	Classic	-.00251750*	.0007251	.021	-.0046705	-.0003645
		Design A	-.00022650	.0007251	.989	-.0019265	.0023795	
		Design B	-.00050225	.0007251	.898	-.0026552	.0016507	

Table 3. A Multiple Comparison of Strain (Turkey HSD) Between groups.

c.) Safety Factor

In engineering, a factor of safety (FoS), also known as (and used interchangeably with) safety factor (SF), expresses how much stronger a system is than it needs to be for an intended load. Safety factors are often calculated using detailed analysis because comprehensive testing is impractical on many projects, such as bridges and buildings, but the structure's ability to carry a load must be determined to a reasonable accuracy. This helps us determine whether the intended design would be able to withstand the uniform pressure. With that said, Design holds a degree of superiority or increased safety as compared to all other safety factors being enlisted is not of equal nature. This suggests that there is significant evidence that indicates that Design A has a greater or a better minimum safety factor.

SafetyFactor	Tukey HSD	Classic	Design A	Design B	Design C	Design A	Design B	Design C
or	Classic	Design A	-.1808250	.0546409	.028	-.343048	-.018602	
		Design B	-.1111000	.0546409	.230	-.273323	.051123	
		Design C	-.1520500	.0546409	.069	-.314273	.010173	
	Design A	Classic	.1808250	.0546409	.028	.018602	.343048	
		Design B	.0697250	.0546409	.594	-.092498	.231948	
		Design C	.0287750	.0546409	.951	-.133448	.190998	
	Design B	Classic	.1111000	.0546409	.230	-.051123	.273323	
		Design A	-.0697250	.0546409	.594	-.231948	.092498	
		Design C	-.0409500	.0546409	.875	-.203173	.121273	
	Design C	Classic	.1520500	.0546409	.069	-.010173	.314273	
		Design A	-.0287750	.0546409	.951	-.190998	.133448	
		Design B	.0409500	.0546409	.875	-.121273	.203173	
Games-Howe II	Classic	Design A	-.1808250	.0524114	.066	-.376379	.014729	
		Design B	-.1111000	.0463830	.188	-.277720	.055520	
		Design C	-.1520500	.0498999	.096	-.335328	.031228	
	Design A	Classic	.1808250	.0524114	.066	-.014729	.376379	
		Design B	.0697250	.0590022	.659	-.136423	.275873	
		Design C	.0287750	.0618051	.964	-.185483	.243033	
	Design B	Classic	.1111000	.0463830	.188	-.055520	.277720	
		Design A	-.0697250	.0590022	.659	-.275873	.136423	
		Design C	-.0409500	.0567829	.885	-.238202	.156302	
	Design C	Classic	.1520500	.0498999	.096	-.031228	.335328	
		Design A	-.0287750	.0618051	.964	-.243033	.185483	
		Design B	.0409500	.0567829	.885	-.156302	.238202	

Table 4. A Multiple Comparison of Safety Factor(Turkey HSD) Between groups.

d.) ANOVA

In table 5. A, we can acquire the necessary values to determine whether to reject or not reject the null hypothesis. With this assumption, we can draw a conclusion whether said designs would perform better or equally to that of the classic design. Utilizing the p-value or the significance that can be observed in the table, we indicate that with the use of Von mises as a factor, there is significant evidence indicating that designs collectively perform better than that of the classic design. This conclusion can also be associated with the Strain and Safety Factor as determinants. This ensures that the designs are remarkable in terms of structural and thermal properties.

		Sum of Squares	df	Mean Square	F	Sig.
VonMises	Between Groups	5892.959	3	1964.320	5.925	.010
	Within Groups	3978.085	12	331.507		
	Total	9871.043	15			
Strain	Between Groups	.000	3	.000	5.947	.010
	Within Groups	.000	12	.000		
	Total	.000	15			
SafetyFactor	Between Groups	.076	3	.025	4.216	.030
	Within Groups	.072	12	.006		
	Total	.147	15			

Table5.A. ANOVA

V. CONCLUSION AND RECOMMENDATION

A. Summary

After determining the factors that have a significant impact on the thermal resistance or the thermal conductivity of a particular object, its design holds a considerable effect on the flow of heat between 2 mediums, which are the concrete walls and the air within the cavities. It has been determined that each cavity aids in reducing the rate of heat transfer from one side to another. It can quantitatively be said as there is a 30.34% and 40.56% decrease in velocity for one cavity to 2 cavities and from one cavity to 3 cavities. Although, the number holds a considerable amount of thermal resistance. It can also be said that an increase of dimensions of these cavities would help aid in reducing heat transfer. Incorporating this concept into the design would greatly reduce the transfer of heat from the outside environment.

Sketching a design that incorporates the concept of an increment of thermal resistance would involve the use Fusion 360 to finalize and incorporate the appropriate material property of said hollow block. This ensures that this design can be realistically tested and possibly made. After applying a uniform pressure of 16, 14, 12, 10 MPa, we can derive the necessary data to determine the effectiveness of the design with respect to classic or typical design. This process is all done using a non-linear stress simulation. This allows us to determine the safety factor that can be observed in each addition of a pressure, which can be done using the slider in the bottom right corner. With the observable data gathered, the use of statistical analysis to derive possible evidence to support the claim of improved structural integrity. The factors of observation would be Von Mises Stress, Strain, and Safety Factor. With a confidence interval of 95%, an ANOVA and a TUSKEY HSD Multiple Comparison Test. This is to determine, whether which design is more suitable or better than the other. These tests also help clarify the general notion of determining the effectiveness of the designs. It has been determined that all designs surpass the classic design in one factor or more, reflecting the general superiority of the design. Another assumption that can be made is the Design A exceeding the

other designs, including that of the classic design. In terms of the three factors, design A is less strained and less stressed at equal and uniform pressures. This would indicate that Design A is the most theoretically improved design with the inclusion of an improved thermal resistance.

B. Conclusion

It has been determined each design has certain traits that makes it more preferable than the classic design. In the case of Design B and C, they hold a degree of improvement in terms of its reduced stress and strands. Despite this evidence, Design A has enhanced or more desirable characteristics as compared to other designs is more significantly better or improved. This leads to the idea that Design A can be an appropriate substitution to that of the commonly used design, which would greatly alleviate the common problems that Filipino engineers face on a daily basis. Another possible benefit that its design holds is that due to the decreased presence of stress compared to that of the original design, it would greatly reduce damages involving natural disasters such as earthquakes. Although, this statement can be supported by the evidence of a decrease in stress. Further testing would be required to determine the exact effectiveness or results of it undergoing such specific tests. This design also holds an improved thermal resistance to hinder the movement of heat at a greater level. This is observed by the implementation of larger and more apparent air gaps, which out the need to reduce the structural integrity of the design. This design would require further experiment under real life conditions without the need to imply idealistic traits to allow said design to be adapted by most construction projects

C. Recommendations

Based on the results obtained in the study, the following are recommended for improvement of findings:

1. Further testing on the feasibility of the real-life application by means of producing a prototype of the desired Design.
2. Determining strength and structural capabilities during an earthquake.
3. Imploring the implementation of aggregate substances to be added into its constituents to improve characteristics and properties of the block.

REFERENCES

- [1] Maroliya, M., (2012), Load Carrying Capacity of Hollow Concrete Block Masonry Wall, International Journal of Engineering Research and Applications, Vol 2, Issue 6, pp 382-385, Retrieved from : https://www.ijera.com/papers/Vol2_issue6/BF26382385.pdf
- [2] Luan, H., Kang, Q., Liu, T., (2017), Cause Analysis and Control Measures of Cracks in Filling Wall of Reinforced Concrete Structure, Chemical Engineering Transactions, Vol 59, Retrieved from : <https://www.aidic.it/cet/17/59/089.pdf>
- [3] Jha, S., Martinez A., Quising, P., Ardaniel, Z., Wang, L., (2018) Natural Disasters, Public Spending, and Creative Destruction : A Case Study of the Philippines, No. 817, Retrieved from : <https://www.adb.org/sites/default/files/publication/408351/adbi-wp817.pdf>
- [4] Antar, M., Baig, H., (2009), Conjugate conduction-natural convection heat transfer in a hollow block building block, Applied Thermal Engineering, Vol. 29, Issues 17-18, pp 3716-3720, Retrieved from : <https://doi.org/10.1016/j.applthermaleng.2009.04.033>
- [5] Chidambarathanu, N., Retnan, R., (2012) Vulnerability of Reinforced Concrete Structures Subjected to Flood, DOI: 10.5772/538979
- [6] Kus, H., Ozkan, E., Gocer, O., Edis, E., (2013), Hot box Measurements of Pumice Aggregate Concrete Hollow Block Walls, Construction and Building Materials, Vol. 38, pp 837-845, Retrieved from : <https://doi.org/10.1016/j.conbuildmat.2012.09.053>
- [7] Khankhaje E., Salim M.R., Mirza J., Hussin M.W., Ho C.S., Rafieizonooz M., 2017, Sustainable pervious concrete incorporating palm oil fuel ash as cement replacement, Chemical Engineering Transactions, 56, 445-450, DOI: 10.3303/CET1756075
- [8] Elgaali, E., & Elchalakani, M. (2013). Concrete hollow blocks made with recycled coarse aggregate and recycled water “ Green blocks ”.
- [9] Comedis, E., Aryan, J., Lorraine, S., Camacho, J., De Leon, J., Segura R., (2017), Modern Eco-Friendly Containers: Transforming Water Lilies into Proactive Environmental Product. Retrieved from: <https://www.dlsu.edu.ph/wp-content/uploads/dlsu-research-congress-proceedings/2017/SEE/SEE-I-005.pdf>
- [10] Varshney, Harshit. (2015). A Review Study on Different Properties of Hollow Concrete Blocks, Retrieved from : https://www.researchgate.net/publication/344171495_A_Review_Study_on_Different_Properties_of_Hollow_Concrete_Block
- [11] Sureshchandra, H.S. & Sarangapani, G. & Kumar, B.. (2014). Experimental Investigation on the Effect of Replacement of Sand by Quarry Dust in Hollow Concrete Block for Different Mix Proportions. Int. J. Environ. Sci. Dev.. 5. 15-19. 10.7763/IJESD.2014.V5.443.
- [12] Fortes, E., Parsekian, G., Fonesca, F., 2014. Relationship Between the Compressive Strength of Concrete Masonry and the Compressive Strength of Concrete Masonry Units, American Society of Civil Engineers.

- [13] Mohammed, B. Hossain, K., Swee, J., Wong, G., M. Abdullahi, 2012, Properties of crumb rubber hollow concrete block, *Journal of Cleaner Production*, Volume 23, Issue 1, Pages 57-67, Retrieved from : <https://doi.org/10.1016/j.jclepro.2011.10.035>.
- [14] Safinia, S., Alkabani, A., (2016), Use of Recycled Plastic Water Bottles in Concrete Blocks, *Procedia Engineering*, Vol 164. Pages 214-221, Retrieved from : <https://doi.org/10.1016/j.proeng.2016.11.612>
- [15] Buck W., Rudtsch S. (2011) Thermal Properties. In: Czichos H., Saito T., Smith L. (eds) *Springer Handbook of Metrology and Testing*. Springer Handbooks. Springer, Berlin, Heidelberg. https://doi.org/10.1007/978-3-642-16641-9_8
- [16] M. Kornmann, *Clay bricks and roof tiles: manufacturing and properties*, Société de l'industrie minérale, Paris, 2007.
- [17] H.X. Zhao, F. Magoulès A review on the prediction of building energy consumption *Renew. Sustain. Energy Rev.*, 16 (6) (2012), pp. 3586-3592
- [18] Wu, J., Bai, G., Zhao, H., Li, X., (2015), Mechanical and thermal tests of an innovative environment-friendly hollow block as self-insulation wall materials, *Construction and Building Materials*, Volume 93, Pages 342-349, Retrieved from : <https://doi.org/10.1016/j.conbuildmat.2015.06.003>
- [19] Pawan Saini , Sumit Gangwar , Harsh Mishra (2019) —Comparison in Thermal Conductivity of Hollow Concrete blocks filled with Straw Bales & Tyre Waste| *Journal of Building and Construction Engineering*, 4(1), 1-11 Retrieved from : <http://doi.org/10.5281/zenodo.2913192>