

Original Research Article

DESIGN AND CONSTRUCTION OF A TWO-WAY GAS OVEN

ABSTRACT

An oven is a heated enclosure for heating, baking or drying. An electric oven is a heating device used to heat materials to high temperature when electric current is passed through a high resistance heating element (coil or plate), while the gas ovens uses gas through the cast iron burner as a medium of heating, baking and drying, both electric and gas oven can find their application in many fields and area of discipline like factories, research institutes, school, medical outfits and general laboratory, but more widely used in food industries. In this research work we incorporate the two heating mechanism together in a single system, the gas and the electric heating medium, many components such as: diodes, resistors, transistors, etc. were combined to make a simple circuit which transcends current to the coil which in turns heat up a given enclosure of a cubical box (i.e. the oven chamber). Finally a heat and convenient heating devices which is electric and gas oven was obtained. Also the determination of the properties of various ferrous and non-ferrous materials, electrical installation is installed with maximum safety gadget in-case of hazards. The application of engineering measurement and quality control is assured in our design and fabrication.

Keywords: Oven, gas, electric, heating element, circuit, thermostat, chamber.

INTRODUCTION

Baking is the oldest and most popular food processing techniques that uses the prolonged dry heat by convection rather than the thermal radiation normally in an oven, but also in ashes or on hot stones. It is a complex simultaneous heat and mass transfer process commonly applied in food industries [1]. This designed and produced will satisfy the basic home needs and sell competitively at the internal scene (local market) and even at higher level (exportation). Having used various domestic gas baking oven, the idea of inventing two way or multi-way baker is necessary, due to the interrupted power supply in our country, we feel that inventing a multi-way oven for domestic and industrial use is inevitable. The idea of using almost local sourced raw materials in producing a product of comparative standard at affordable cost was developed. This two-way oven although may not be the first of its kind, it is an improvement on the copied technological ideas already in existence, meanwhile the use of electricity and gas baking oven with temperature regulator but aimed at easing the difficulties in its maintenance and serving this equipment has got almost all its components separated. The burner sits on a carbonated cover plate bolted together and this can be lifted out easily to enhance easy access to the burner gas channels and the control valve nozzle. The temperature control is placed on the top of the entire system for easy access, the oven burner units are made up of two separate components parts, in case there is need for replacement of a faulty component, the design is very simple and it provides easy access to fix any bad components without wasting time. The intensity of the burning flame including that of the oven can be altered to various temperature levels by adjusting the valves nozzle. The opening under the cabinet which can create a channel for air/gas mixture for effective burning, since adequate supply of air is necessary for burning when using a gas fuelling system, on the other way, when using an electric burner, this system has been modified in such a way that the thermostat automatically cuts supply of heat to the system when the preset temperature has been reached, and this also serves as a safety measure in our design. All these have been proved that its performance level has a high degree of efficiency and reliability. One major improvement in electric ovens was the invention of resistor heating coils, a familiar design in ovens also seen in hotplates. The oven is a bi-product of the Russian stove and has been a great addition to a gas or electric cooker for many years. An oven can also be simply described as a fully enclosed thermally insulated chamber used for the heating, baking or drying of a substance. In a baking oven, the hot air flows over the baking material either by natural

convection or forced by a fan, the convection heat transfer from the air, the radiation heat transfer from the oven heating surfaces, and the conduction heat transfer across contact area between product and metal surface. The moisture in the food material simultaneously diffuses toward the surfaces, then, it transfers from the surface by convection, and the product loses moisture with continuous movement of the oven ambient air. These are the simultaneous momentum, heat and moisture transfer mechanisms within a baking product [2] and between the product and its environment [3], which theoretically are well known. Commercially, ovens are available in the various configurations like electric ovens, micro oven and wood oven etc. However, today many home chefs prefer to buy separate ovens, as their features and capabilities are far better than those of cookers with a built-in oven. Ovens are classified into different types depending, not only on the method of usage (dependent and independent) but also on the heating method. As well as cookers, ovens can be gas or electric. Both have their advantages and disadvantages, and depending on your goals, habits and the size of your purse, you can choose either type. Therefore, it is difficult to say which oven is better, gas or electric. You need to familiarize yourself with the features and characteristics of each type and select the best option for yourself. The main advantage of gas ovens is they are inexpensive to use. Many houses have gas lines already installed. Gas is cheaper than electricity, so it is more inexpensive to cook with this type of oven. Many people use gas ovens in country houses. They function with the help of gasbags, which are still cheaper than electricity. Gas ovens are usually chosen by the home chefs that are used to regular cookers. They know the capabilities of gas heating and can quickly learn to use a new appliance that works on the same principle. Gas ovens heat from the bottom, as the heating elements are located on the bottom of the oven. Most home chefs value the simplicity as the main quality of these ovens. The gas models have no unnecessary features, complex settings, and provide additional options for different kinds of pastries. It is easy to adjust the temperature of the oven and there is no need to wait long for it to warm up. The construction of the gas oven is simple and reliable, and it can last for several decades. If the power ever goes out in a home a gas oven can still be turned on for food uses. Gas ovens have their disadvantages. Firstly, cheap gas ovens do not provide a uniform temperature distribution, and the dish can burn slightly from one side and stay raw from the other [4]. Secondly, even if there are special security features, there is still a risk of gas leakage, and the oven needs to be carefully monitored. Electric ovens provide a very high accuracy and a wider range of temperature levels. These ovens can be

warmed up to 575 degrees Fahrenheit, gas oven provides the temperature of 445 degrees maximum. This allows you to vary your diet with unusual dishes that require high temperatures. Electric ovens are multi-functional; they are equipped with multiple modes of heating, baking programs, convection, timers and many more features that allow you to vary the time and methods of preparation and provide the comfort and ease of cooking, such ovens are equipped with pyrolytic cleaning. While heating all the dirt and grease turn to ashes, or catalytic cleaning, when special enamel splits the dirt. These ovens are more expensive than gas ones, both in the price of the oven itself and in the cost of use. But they are superior to gas ovens in many other qualities [5].

MATERIALS AND METHOD

2.1 Essential Design Parts

2.1.1 The Body: The body of the two-way electric and gas oven comprises of the entire parts which makes up the complete system or mechanism of the oven, they are further described below.

2.1.2 The Oven Burners: The two-way oven system consists of cast iron industrial burner and high wattage heating element to provide adequate heating to the food materials.

2.1.3 The Temperature Regulator: This control the amount of heat supplied to the food materials in the oven chamber; we have a thermostat for the electric control system, while we have a control nozzle for controlling the gas supply.

2.1.4 The Locking Device: This is a safety device to provide a lock against heat leakage or otherwise.

2.1.5 The Temperature Sensor: The temperature sensor monitors the preset temperature and the amount of heat supplied to the oven chamber.

2.1.6 The Electrical Wiring Diagram: This is the circuit diagram that controls the electrical system of the oven

2.1.7 The Gas Cylinder: This is the reservoir for the gas to be supplied to the gas burner. It is manufactured in varying sizes such as 5kg, 7.5kg, 12.5kg, 25kg, 50kg and so on, depending on the customer want.

2.1.8 The Pipe Line/Hose: This is a gas supply line to the oven gas burner. It is made up of reinforced fibre and rubber to ensure maximum leak free, also the reinforcement provide more strength to withstand a very high gas pressure without being busted.

2.1.9 The Equi-Temperature Blower: This is an air blowing system to ensure adequate supply of well distributed quantity of heat to the oven chamber. It comprises of an a.c powered fan to provide maximum and evenly supply of hot air into the oven chamber. This design result in superior temperature uniformity, although many different factors influence the uniformity in a commercial oven, they include controller calibration, sensor calibration, sensor placement within the work area, oven temperature (high temperature/greater variable), circulation (the greater the air circulation/the better the uniformity [4].

2.2 Mode of Operation

On the control panel, the following symbols are indicated around each knob "M" or on the knob itself: Cock. Moreover, the symbols near the knobs indicate the position of the relative burner on the hob. The burners are fitted with a safety thermocouple device against gas leaks. This device interrupts the gas supply should the burner flame go out during operation.

To **light one of the burners**, proceed as follows:

- Turn the relative knob anti-clockwise until the pointer is on the high-flame symbol;
- Press the knob down fully to actuate the automatic gas ignition;
- Keep the knob pressed down for about 6 seconds with the flame lit to allow the safety thermocouple to heat;
- Release the knob, checking that the flame is stable. If it is not, repeat the operation. For minimum power, turn the knob towards the low flame symbol. Intermediate positions are possible by simply setting the knob anywhere between the high and the low flame symbol.

To **turn the burner off**, turn the knob clockwise until it stops (corresponding again with the “ ” symbol).

To **operate the electric heating element**, proceed as follows:

The oven heating element consists of a thermocouple safety device. This device automatically cuts off the electric supply to the heating element once the preset temperature has been reached. This is more neat and do not produce any pollution on the food material, it is very easy to operate, it requires setting the thermostat to the desired temperature and it will automatically stopped once reached the desirable temperature. The figure1 show an example of two-way oven for commercial use.

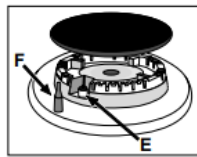
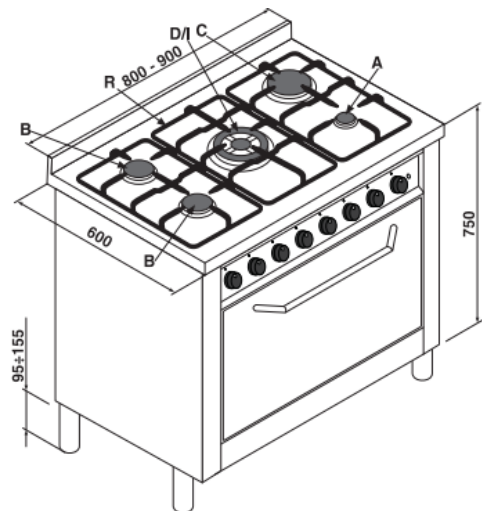

fig.1

- A Auxiliary gas burner
- B Semi-rapid gas burner
- C Rapid gas burner
- D Triple ring gas burner
- DC-DR gas burner
- E Ignitor for Gas Burners
- F Safety Device - Activates if the flame accidentally goes out (spills, drafts, etc.), interrupting the supply of gas to the burner.
- G Electric oven selector knob (cooking mode selection)
- H Electric oven thermostat knob (temperature selection)
- M Control knobs for gas burners
- R Support grid for cookware
- P Timer
- S Electric heating element indicator light
- T Minute minder
- U End of cooking programmer
- V Gas oven thermostat knob (gas oven mode selector with temperature adjustment and electric grill)
- Z Gas oven light button

Figure 1 Two-way Electric and Gas Oven for commercial use.

Production Process

A new design of two-way gas and electric baking oven has been fabricated according to the design with the use of indigenous material. The oven consists of housing unit, thermometer, outlet nozzle, electric heating element, cast iron gas burner, blower and thermostat. The housing unit represents the entire out look of the baking oven. The housing unit of the electric and gas oven was made up of three layers that was outer stainless steel of thickness 26 gauge with the dimension 450×350×380 (Length × Width × Height) mm, inner layer was made out of aluminum sheet of thickness 24 gauge with the dimension of 380×310×340 mm (Length × width × height) and the middle layer of the two way electric and gas oven consist thermal insulating material such has silicone rubber and the insulator to lag all the four sides of the oven. These two material acts as an insulator to avoid the loss of the heat from the inner baking chamber to the outside ensures for the even baking of the product in the baking chamber. The door of the gas oven was made up of the stainless steel and insulator lag sheet of thickness 5 mm was placed in between the steel plate to avoid the loss of heat through the door and in the front of the door provided with the toughened glass to monitor the inside baking product without opening the door. The base of the inner baking chamber was provided with the deflector plate of the thickness of 3mm with dimension of 240×200 (length × width) mm placed at a height of 40 mm from the base of the oven to avoid the direct flame from the burner to the baking chamber and to the even distribution of the heat throughout the baking chamber as shown in the diagram

Choice of Assembly and Procedure

In our design, we adopt simplicity on the integration of assembly all the parts for easy accessibility, this design is very simple to trace of fix any minor fault without looking for a skilled personnel, also our design is based on the ergonomics principles for easy movement and usage with little ideas on the operation principle. Finally, Safety is taken as paramount in this fabrication; all the risk of hazards and electrocution was well addressed.

Welding

Welding is the process of joining of two or more pieces of materials especially metals with the help of heat and pressure. The different types of welding process are

(1) Gas Welding: Examples of gas welding are, Air acetylene, Oxy hydrogen welding, Oxy acetylene

(2) Arc Welding: Examples of Arc welding are, Shielded Metal Arc Welding (SMAW), Metal Arc Welding (GMAW) or (MIG), Flux-Cored Arc Welding (FCAW), Submerged Arc Welding (SAW), Gas Tungsten Arc Welding (GTAW) or (TIG), Plasma Arc welding (PAW), Atomic Hydrogen Welding (AHW), Carbon Arc Welding (CAW), Electro-slag Welding (ESW) and Electro-gas Welding (EGW).

(3) Resistance Welding: Examples of resistance welding are, Seam welding, Projection welding, Spot -welding, Flash welding, Resistance Butt welding.

We adopt manual metal arc welding process and gas welding only in our design. The choice of welding method to be used depends on the type of materials, and metal thickness .The electric oven is embedded with a steel plate floor and double doors on each end, in this case we choose arc welding, and use a grinder to smoothen the surface for perfection.

4.1.2 Riveting

A **rivet** is a permanent mechanical fastener, before being installed; a rivet consists of a smooth cylindrical shaft with a head on one end. In our design we rivet some parts where joining is inevitable, and welding is not applicable, for example the burner end is riveted to its basement.

4.1.3 Threading

This is the process of creating a screw thread, thread creation can either be deformative or transformative methods (rolling and forming; molding and casting); additive methods (such as 3D printing); or combinations thereof. In our design, many parts were threaded in order to provide adequate coupling or fastening of the parts together.



(1)



(2)



(3)



(4)



(5)

Figure 2: Pictorial-view of the Two-way Electric and Gas Oven

RESULTS and DISCUSSION

The two-way electric and gas baking oven was put to test in order to determine its functionality and the effectiveness through baking some food items like cakes, cookies and the muffins. The oven works majorly by convection mode of heat transfer. The experiment was performed for the each of them while measurements were taken with respect to the corresponding time taken for the baking of the particular food items.

Baking of Cake

The cakes of the different size was baked in the using the gas portion of the oven at a temperature range of the 170-180°C. The time taken by the gas oven for the baking of the cakes shown in the Table 1, from this its shows that, has size of the cake increases the time required for the baking also increases. The quality parameters like the volume, color and the texture of the cake was well developed and was acceptable.

Table 1:Baking Time of the Cakes

Product	Time Taken to Bake
Cake (small size)	19min
Cake (medium size)	28min
Cake (Large)	37min

6.2 Cookies, Muffins, and Bread Loaf

The cookies was baked using electric oven, the time taken for the baking of the cookies was shown in the table at the baking temperature of 160° C , while the muffins was baked in an electric oven at 190°C, and bread loaf is set at temperature 220°C as shown in table 6.2. Cookies, muffins and bread loaf are baked evenly and the texture and the color of the cookies and the bread loaf is fantastic and acceptable

Table 2: Baking Time of the Cookies and Muffins

Product	Time Taken to Bake
Cookies	9min
Cake	14min
Bread loaf	18min

Conclusion

From this study it is evidently clear that the designed Two-way Electric and gas oven can be better used for commercial purposes in the baking of the cakes, cookies, bread loafs and all the bakery products with good quality parameters like color, texture and the taste and good volume in the fermented products and also the pre heating time of the both the electric and gas oven was also reduced this in turn as less energy is consumed and the time of the baking and reduces the overall working cost. This can be used for commercial purposes and can be popularized in areas where power cuts are more frequent and power is available for limited hours. Due to its advantages, it can be use when there is electricity or not. Although, the gas portion of the oven is having the disadvantages of controlling the temperature within the baking chamber.

Recommendation

The Two-way Electric and Gas Oven is therefore recommended for both domestic and commercial use because, it has dual advantages of using both gas and electricity, it can be used in both remote and urban areas, more so, the efficiency is estimated around 90%, which make it better than all the imported ones. In addition, because all the materials used for our fabrication are locally sourced, we ensure that high grade and fillet gauge of steel are used so as so prevent quick wear and rust. Summarily, I have no doubt in the efficacy of this research work for both domestic and commercial use.

References

1. Genitha, I., Lakshmana Gowda, B. T., John D.R., *Design, Fabrication and Performance Evaluation of Domestic Gas Oven*. IOSR Journal of Engineering (IORJEN), 2014. 04(05): p. 35-38.
2. Tong, C.H., Lund, D.B., *Effective moisture diffusivity in porous materials as a function of temperature and moisture content*. Biotechnology Progress, 1990. 6: p. 67-75.
3. Carvalho, M.a.M., N., *Mathematical modeling of heat and mass transfer in a forced convection baking oven*. AIChE Symposium Series – Heat Transfer, 1993. 88(288): p. 205-211.
4. <https://www.pqovens.com/ovens>, Access on 10th, October, 2019.
5. Therdthai, N., Zhou, W., and Thomas, A., *Three-dimensional CFD modeling and simulation of the temperature profiles and airflow patterns during a continuous industrial baking process*. Journal of Food Engineering, 2003. 65: p. 599-608.