

## Modelling HIV/AIDS Infection Dynamics in the Presence of Interfered Interventions

**Abstract** Mathematical models are invaluable tools for describing and understanding disease dynamics. In this study, we propose and analyse a mathematical model for HIV/AIDS in order to assess the impact of interfered interventions on the disease dynamics. The model enables us to study the role of treatment in the presence of interfered interventions, as a control strategy for reducing the HIV pandemic. We performed thorough qualitative analysis on the reproduction number of the model,  $\mathcal{R}_0$ . The global and local dynamics of the system are also considered, that is, we analyse the two equilibria states of the model, namely; the disease-free equilibrium and a unique disease-persistent equilibrium. The disease-free steady state is shown to be globally asymptotically stable whenever  $\mathcal{R}_0 < 1$  and the endemic equilibrium is globally asymptotically stable whenever  $\mathcal{R}_0 > 1$ . We conducted numerical simulations to support the analytical results. The results of the model analysis indicate that interference has the effect of reducing treatment uptake and increasing the rate of drop-outs. The results have implications in the designing of policies in countries with war, economic turmoil or any other form of disturbance.

**Keywords** HIV/AIDS, Interference, Reproduction number, Treatment, Mathematical model

### 1 Introduction

HIV virus which causes AIDS still poses a serious public health threat in various parts of the globe especially in the Sub-Saharan Africa. According to [24], approximately 36.9 million individuals globally were living with the HIV virus in 2017, of whom about 21.7 million were on antiretroviral therapy (ART). In an attempt to combat the onward transmission of HIV, UNAIDS implemented prevention strategies in 2014 with an ambitious goal of reducing new infections to less than 500,000 by year 2020 [22]. The control mechanisms proposed and implemented by the World Health Organization (WHO) and UNAIDS include the use of female and male condoms, antiretroviral treatment to suppress the viral load in HIV patients, pre-exposure prophylaxis (PrEP) for those who are at risk of acquiring the infection, voluntary male circumcision, educational campaigns, provision of opiate therapy, use of clean syringes and needles among others.

---

---

However, according to [24], the new infections recorded in 2015 were about four-times the 2020 target despite the implementation of the WHO guidelines, indicating that more effort is still required in the war against the HIV epidemic. The high HIV incidences can be attributed to some situations that make the implementation of these HIV interventions difficult. For instance, conditions such as war and conflicts, political instability, poverty, migration and economic challenges limit the implementation of prevention mechanisms hence fuelling the transmission of the disease [24]. Occurrence of disasters such as wars and conflicts subject people to harsh conditions which makes them vulnerable to human rights abuses such as rape and mass displacement. Furthermore, such calamities also interrupt the access of health care services making it difficult for HIV/AIDS victims and other patients to access treatment services [5].

According to UNAIDS, there is no single control mechanism that has a powerful impact in lowering HIV prevalence and incidence levels, but a combination of several intervention strategies can significantly reduce new infections. However, failure to implement some of the proven HIV interventions systematically and consistently have slowed down the reduction in new HIV infections [22]. The cases of drop outs or failure to adhere to antiretroviral treatment enhances HIV transmission since it has been established that routine monitoring of the viral load is an effective HIV prevention tool [24]. Adherence to antiretroviral drugs suppresses the viral load in HIV patients to undetectable levels and such patients cannot transmit the virus to others [22]. Therefore, poor adherence to antiretroviral therapy will not only facilitate HIV transmission but also increases the mortality rates of the infected individuals.

## 2 Literature Survey

Mathematical models have played an important role in understanding and describing the epidemiological patterns for the proliferation and control of HIV. Incorporation of HIV interventions in these model systems has attracted significant attention recently. A combination of early diagnosis followed by immediate treatment to suppress the viral load have been proposed as effective interventions in minimizing the HIV incidence in numerous models. For instance, Okosun et al. [13] presented a mathematical model to determine the effects of prevention intervention strategies on the spread of HIV. Furthermore, [19] proposed a compartmental model to examine the impact of treatment and screening of individuals who are unaware of their HIV status. It was noted that screening and enrollment of treatment for HIV positive individuals is beneficial in mitigating HIV/AIDS infection. More work on mathematical modelling of HIV transmission, prevention, testing and treatment can be found in the following works; [10, 12, 21, 1, 7, 20, 4, 9, 15, 14].

Considering that emergency crises do not only subject affected individuals to the risk of acquiring HIV virus but also disrupt the existing HIV/AIDS programmes [24]. There is need to develop a mathematical model that assesses the impact of situations such as war, political instability, poverty, economic challenges, drought, nutritional challenges and other factors on the HIV disease dynamics. In this study, we propose a mathematical model for HIV that focuses on the factors that can hinder smooth implementation of prevention strategies. The primary focus of this study is to model HIV/AIDS infection dynamics in presence of interfered interventions where the effect of factors that hamper HIV prevention strategies are considered in detail. This work forms an initial attempt to explicitly capture the role of interference in HIV disease dynamics not considered in past models.

### 3 Model Formulation and Analysis

#### 3.1 System Description

We formulate a new mathematical model based on a susceptible-infected (SI) deterministic model to understand and describe HIV transmission dynamics in presence of interfered interventions. We present a model that partitions the total human population  $N(t)$  into four mutually-exclusive classes:  $S(t), I(t), T(t)$  and  $A(t)$ . We assume that the total human population  $N(t)$  at any given time  $t$  is denoted by Equation (1)

$$N(t) = S(t) + I(t) + T(t) + A(t). \tag{1}$$

The first class  $S(t)$  represents the susceptible individuals,  $I(t)$  consists of HIV-positive patients at asymptomatic stage of the infection,  $T(t)$  comprises of HIV-positive individuals receiving ART treatment and lastly  $A(t)$  represents patients at the symptomatic stage of HIV infection. We categorize the stages of HIV/AIDS infection into two, that is, infected people in the asymptomatic stage ( $I$  and  $T$ ) of the infection and those in pre-AIDS stage or full-blown AIDS ( $A$ ).

Interfered interventions have devastating impact on the spread of HIV/AIDS. In this study, we will utilize the standard incidence to model HIV/AIDS transmission dynamics. Therefore, the total number of new HIV infections triggered by infected individuals at the asymptomatic stage of HIV infection and HIV victims under treatment are obtained by using the force of infection  $\lambda$ , which can be modified as

$$\lambda = \begin{cases} (\beta_{max} + \epsilon_1 \omega)(I + \eta T), \\ \beta_{max} e^{-\epsilon_2 \omega} (I + \eta T), \\ \frac{\beta_{max}}{1 + K e^{-\epsilon_3 \omega}} (I + \eta T), \end{cases}$$

where  $\beta_{max}$  represents the effective transmission rate for the HIV virus,  $K$  represents the scale parameter,  $\epsilon_1, \epsilon_2, \epsilon_3$  represents the shape parameters that determine how fast the impact of the disease can be felt,  $\omega$  is the impact of any process that interferes with interventions and  $\eta$  is the relative infectivity of  $T$  with respect to  $I$ ,  $\eta \in (0, 1)$ . The forms of  $\lambda$  presented here, present the various possibilities or probable function that can used to measure the increased infection rate due to interference.

In this paper, we propose a force of infection  $\lambda$ , that is dependent on the presence of interfered interventions given by,

$$\lambda = C(\omega)(I + \eta T),$$

where the function  $C(\omega)$  describes the effective contact rate given by

$$C(\omega) = \frac{\beta_{max}}{1 + K e^{-\epsilon \omega}}. \tag{2}$$

In the model, when  $\omega = 0$  then there are no processes that can hamper HIV interventions and the disease spreads normally in the population at a rate  $\beta_{max}/(1 + K)$ . However, maximum interference on HIV interventions is experienced when  $\omega = 1$ . We choose parameters  $K$  and  $\epsilon$  carefully such that maximum HIV transmission rate,  $\beta_{max}$  occurs when  $\omega = 1$ . Therefore transmission dynamics of the disease depends on the value of  $\omega$  as described in Figure 1.

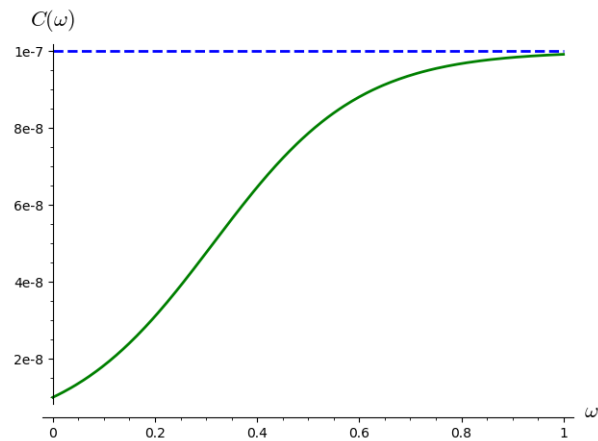

**Fig. 1** Graphical representation of HIV infection rate in presence of processes that limit interventions with  $(\beta_{max} = 1 \times 10^{-7}, K = 9, \varepsilon = 7)$ .

From Figure 1, it can be observed that there is a functional relationship between  $C(\omega)$  and  $\omega$ . Therefore, Equation (2) predicts that as the factors that hinder HIV interventions increases then the HIV infection rate in the population increase gradually initially, then rapidly, slows down again as  $\omega$  approaches 1 and reaches its maximum value when  $\omega = 1$ .

A schematic representation of HIV/AIDS transmission dynamics in the presence of interfered interventions is shown in the Figure 2

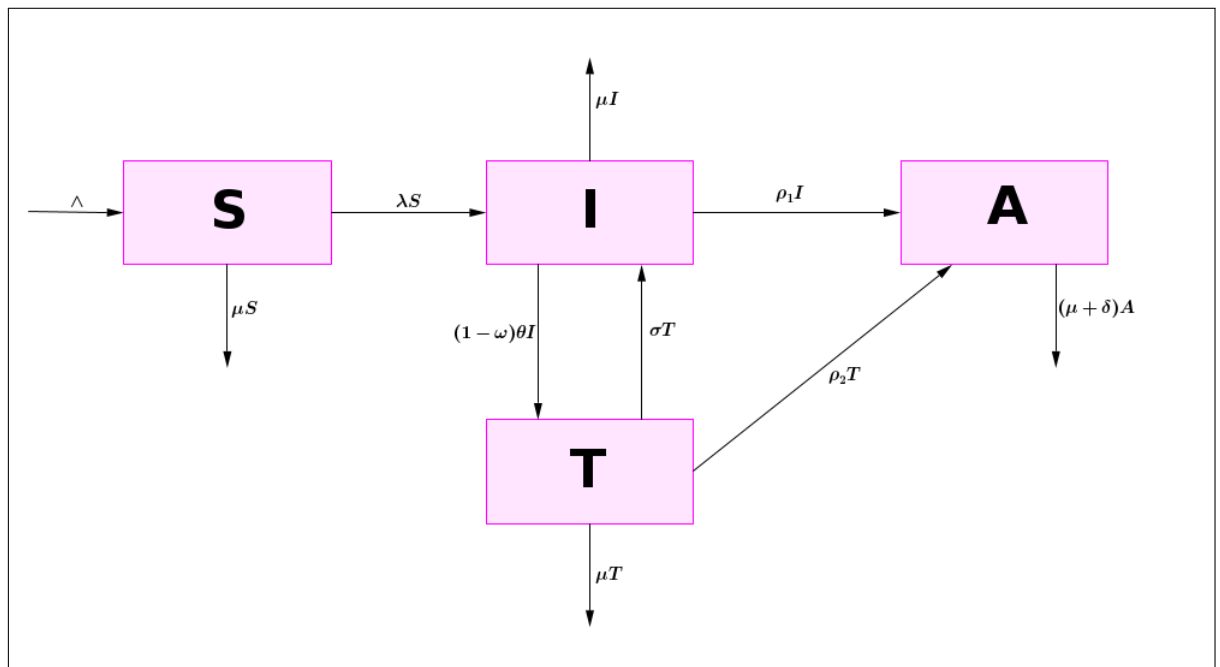

**Fig. 2** A model for HIV/AIDS infection dynamics in presence of processes that limit interventions.

### 3.2 Model Assumptions

The key assumptions made in the model include:

1. There is homogeneous spatial distribution (mixing) of infected and HIV-negative individuals.
2. HIV virus is transmitted via heterosexual means.
3. HIV patients at the symptomatic stage of the HIV infection (class  $A$ ) are at the terminal stage of the HIV infection and they do not contribute to the spread of the disease since they are unable to transmit the virus via sexual activity.

Now we consider the movement of populations between compartments in Figure 2 with time. Firstly, we assume that the population is recruited into susceptible class at a constant rate  $\Lambda$  and  $\mu$  is the natural death rate for all compartments. Individuals in the susceptible class can acquire HIV virus with the force of infection  $\lambda$ . Each newly HIV infected individual progresses to the infected class ( $I$ ) at a rate  $\lambda$  and those screened for the virus and put on ART treatment move to compartment ( $T$ ) at a rate  $(1 - \omega)\theta$ . Note here that as  $\omega$  increases the rate of movement from compartment  $I$  to  $T$  slows down, that is, interference is assumed to slow uptake into treatment programs. So, we assume that interference increases the infection rate and reduces the uptake into a treatment program. The processes that impede HIV treatment have been incorporated in the model and  $0 \leq \omega \leq 1$  measures the impact of any process that hinder HIV treatment. From the model, we can observe that as  $\omega$  increases the rate of the infected people accessing medication decreases and no HIV patient can access treatment services when we have maximum interference, that is, when  $\omega = 1$ . Persons who withdraw from ART therapy can either return to the infected class at a rate  $\sigma$  or move to full-blown AIDS stage ( $A$ ) at a rate  $\rho_2$ . HIV patients in the infected class ( $I$ ) can also move directly to the symptomatic stage of the HIV infection ( $A$ ) at the rate  $\rho_1$ . In addition, we assume that the infected individuals in the symptomatic stage of HIV/AIDS infection ( $A$ ) experience an additional mortality rate  $\delta$ ; due to AIDS unlike the other individuals in the other compartments.

### 3.3 Model Equations

The dynamics described in the Figure 2 is governed by the following non-linear system of differential equations

$$\left\{ \begin{array}{l} \frac{dS}{dt} = \Lambda - \mu S - \lambda S, \\ \frac{dI}{dt} = \lambda S - (1 - \omega)\theta I - (\mu + \rho_1)I + \sigma T, \\ \frac{dT}{dt} = (1 - \omega)\theta I - (\mu + \sigma + \rho_2)T, \\ \frac{dA}{dt} = \rho_1 I + \rho_2 T - (\mu + \delta)A, \end{array} \right. \quad (3)$$

with the following initial conditions:  $S(0) \geq 0, I(0) \geq 0, T(0) \geq 0$  and  $A(0) \geq 0$ .

**NOTE:** All parameters and state variables in model system (3) are strictly positive for all time  $t \geq 0$  since it monitors the population of humans.

A summary of the model parameters are given in Table 1

Parameter	Description
$\beta_{max}$	Effective contact rate (Infection rate)
$\Lambda$	Recruitment rate
$\omega$	Impact of any process that interferes with interventions
$\theta$	Rate of treatment
$\rho_1, \rho_2$	Progression rates to full-blown AIDS
$\sigma$	Drop out rate
$\mu$	Natural death rate
$\delta$	HIV/AIDS related death
$\eta$	Modification parameter
$K$	Scale parameter
$\varepsilon$	Shape parameter

**Table 1** Description of parameters

### 3.4 Model Properties

In this section, we focus on the basic properties of system (3). We show that all the state variables of system (3) will remain non-negative and that all its solutions with positive initial conditions will remain non-negative for all  $t > 0$ .

#### 3.4.1 Boundedness of Model Solutions

**Theorem 1** *The invariant region  $\Omega$  for the given mathematical model defined by*

$$\Omega = \left\{ (S, I, T, A) \in \mathbb{R}_+^4 \text{ such that } 0 \leq N(t) \leq \frac{\Lambda}{\mu} \right\}, \tag{4}$$

*with initial conditions  $S(0) \geq 0, I(0) \geq 0, T(0) \geq 0, A(0) \geq 0$  is positively invariant for all  $t \geq 0$ .*

*Proof* The total human population is given by Equation (1) and at any given time, the rate of change in the population is given by

$$\frac{dN}{dt} = \frac{dS}{dt} + \frac{dI}{dt} + \frac{dT}{dt} + \frac{dA}{dt} = \Lambda - \mu N - \delta A \leq \Lambda - \mu N. \tag{5}$$

Solving (5) using the integrating factor technique, we get the solution  $N(t)$  such that

$$N(t) \leq \frac{\Lambda}{\mu} + \left( N(0) - \frac{\Lambda}{\mu} \right) e^{-\mu t}. \tag{6}$$

The solution has the property

$$0 \leq N(t) \leq \frac{\Lambda}{\mu} + \left( N(0) - \frac{\Lambda}{\mu} \right) e^{-\mu t},$$

where  $N(0)$  represents initial human population. From (6), we can note that  $N \rightarrow \frac{\Lambda}{\mu}$  as  $t \rightarrow \infty$ . Therefore,  $N(t)$  is bounded above by  $\frac{\Lambda}{\mu}$ . If  $N(0) \leq \frac{\Lambda}{\mu}$ , then we can infer that  $N(t)$  tends to  $\frac{\Lambda}{\mu}$  as time increases. Conversely,  $N(t)$  will decrease to  $\frac{\Lambda}{\mu}$  if  $N(0) > \frac{\Lambda}{\mu}$ . In other words, if  $N(0) > \frac{\Lambda}{\mu}$  then the solutions  $(S(t), I(t), T(t), A(t))$  approaches  $\frac{\Lambda}{\mu}$  asymptotically. Therefore, the solutions of system (3) are bounded.

3.4.2 Positivity of Solutions

**Theorem 2** Given that the initial conditions of system (3) are  $S(0) \geq 0, I(0) \geq 0, T(0) \geq 0$  and  $A(0) \geq 0$  then it follows that the resulting solutions  $S(t), I(t), T(t)$  and  $A(t)$  are all non-negative for all  $t > 0$ .

*Proof* To prove theorem 2 we need to show that each of the trajectories of system (3) is positive for all  $t > 0$ . We let

$$\bar{t} = \sup\{t > 0 : S > 0, I > 0, T > 0, A > 0\} \in [0, t].$$

So  $\bar{t} > 0$  and from the first equation of the system (3), it follows that

$$\frac{dS}{dt} = \Lambda - (\mu + \lambda)S \geq -(\mu + \lambda)S. \tag{7}$$

Solving (7) and integrating both sides with respect to  $t$  over the interval  $[0, t]$  leads to

$$S(t) \geq S(0)e^{-(\mu+\lambda)t} \geq 0.$$

Thus,  $S(t)$  is non-negative.

Similarly, we obtain from the second, third and fourth equation of system (3) that

$$I(t) \geq I(0)e^{-(\mu+\rho_1+(1-\omega)\theta)t} \geq 0, T(t) \geq T(0)e^{-(\sigma+\mu+\rho_2)t} \geq 0, A(t) \geq A(0)e^{-(\mu+\delta)t} \geq 0.$$

Thus,  $I(t), T(t)$  and  $A(t)$  are non negative.

Therefore  $S(t) \geq 0, I(t) \geq 0, T(t) \geq 0$  and  $A(t) \geq 0$  for all  $t \geq 0$ .

The model is well-posed epidemiologically and mathematically since all solutions of system (3) remain non-negative and bounded in the invariant set  $\Omega$ . Therefore, it is sufficient to analyse the dynamics of the proposed model in  $\Omega$ .

3.5 Disease-free Equilibrium (DFE) and Reproduction Number ( $\mathcal{R}_0$ )

At *DFE*, we assume that the total population has not experienced HIV virus infection, the community remains free of the virus. Then, it follows that the entire population becomes susceptible to the infection. Therefore, to obtain the *DFE* we allow all the infected classes to be zero, that is,  $I = 0, T = 0$  and  $A = 0$ . Hence, the disease-free equilibrium of system (3) is given by

$$E_0 = (S^0, I^0, T^0, A^0) = \left(\frac{\Lambda}{\mu}, 0, 0, 0\right).$$

In this model, we assume that the new HIV infections are generated by infected individuals in compartments  $I$  and  $T$ . Reproduction number  $\mathcal{R}_0$  represents the average number of new infections generated by an infectious individual in the population of wholly susceptible individuals [23]. The next-generation matrix technique defined in [23] is used to compute  $\mathcal{R}_0$ .

We consider the compartments that contribute to new HIV infections. We have that the matrix of new infections  $\mathcal{F}$  and the matrix of transitions  $\mathcal{V}$  are given by

$$\mathcal{F} = \begin{pmatrix} \frac{C(\omega)\Lambda}{\mu}I + \frac{C(\omega)\Lambda\eta}{\mu}T \\ 0 \end{pmatrix} \text{ and } \mathcal{V} = \begin{pmatrix} (\mu + (1 - \omega)\theta + \rho_1)I - \sigma T \\ -(1 - \omega)\theta I + (\sigma + \mu + \rho_2)T \end{pmatrix}.$$

Now evaluating the matrices for the states at the DFE yields

$$F = \begin{pmatrix} \frac{C(\omega)\Lambda}{\mu} & \frac{C(\omega)\Lambda\eta}{\mu} \\ 0 & 0 \end{pmatrix} \text{ and } V = \begin{pmatrix} H_1 & -\sigma \\ -H_2 & H_3 \end{pmatrix}.$$

Here,

$$H_1 = \mu + (1 - \omega)\theta + \rho_1, \quad H_2 = (1 - \omega)\theta \quad \text{and} \quad H_3 = \mu + \sigma + \rho_2.$$

We have that

$$FV^{-1} = \begin{pmatrix} \frac{C(\omega)\Lambda}{\mu(H_1H_3 - \sigma H_2)}(H_3 + \eta H_2) & \frac{C(\omega)\Lambda}{\mu(H_1H_3 - \sigma H_2)}(\sigma + \eta H_1) \\ 0 & 0 \end{pmatrix}.$$

The dominant eigenvalue of the matrix  $FV^{-1}$  gives the reproduction number  $\mathcal{R}_0$  of system (3). Thus,

$$\mathcal{R}_0 = \varphi(FV^{-1}) = \frac{C(\omega)\Lambda}{\mu H_1 H_3 (1 - \phi)} (H_3 + \eta H_2) \tag{8}$$

where

$$\phi = \left(\frac{\sigma}{H_3}\right) \left(\frac{(1 - \omega)\theta}{H_1}\right) < 1.$$

Substituting for the values of  $C(\omega), H_1, H_2$  and  $H_3$  in Equation (8) gives

$$\begin{aligned} \mathcal{R}_0 &= \frac{\beta_{max}\Lambda}{\mu(\mu + (1 - \omega)\theta + \rho_1)(\mu + \sigma + \rho_2)(1 + Ke^{-\epsilon\omega})(1 - \phi)} ((\mu + \sigma + \rho_2) + \eta((1 - \omega)\theta)) \\ &= \frac{\beta_{max}\Lambda}{J} [(\mu + \sigma + \rho_2) + \eta\theta(1 - \omega)], \end{aligned} \tag{9}$$

where  $J = \mu [\mu + (1 - \omega)\theta + \rho_1](\mu + \sigma + \rho_2)(1 + Ke^{-\epsilon\omega})(1 - \phi)$ .

From Equation (9), we note that

$$\mathcal{R}_0 = \mathcal{R}_I + \mathcal{R}_T$$

where

$$\mathcal{R}_I = \frac{\beta_{max}\Lambda(\mu + \sigma + \rho_2)}{J} \quad \text{and} \quad \mathcal{R}_T = \frac{\eta\beta_{max}\Lambda(1 - \omega)\theta}{J}.$$

Here, we note that  $\mathcal{R}_I$  is the contribution of individuals in compartment  $I$  to HIV/AIDS infections in the presence of interference which is only reflected in the infection term while  $\mathcal{R}_T$  is contribution of infected individuals in compartment  $T$ .

### 3.5.1 Local Stability of the DFE

**Theorem 3** *The DFE of system (3) is locally asymptotically stable when  $\mathcal{R}_0 < 1$  and unstable otherwise.*

*Proof* We employ the idea of stability matrix to prove theorem 3 above. Thus, the Jacobian matrix of system (3) is given by

$$J(S, I, T, A) = \begin{pmatrix} -(\mu + C(\omega)I + C(\omega)\eta T) & -C(\omega)S & -C(\omega)\eta S & 0 \\ C(\omega)I + C(\omega)\eta T & C(\omega)S - H_1 & C(\omega)\eta S + \sigma & 0 \\ 0 & H_2 & -H_3 & 0 \\ 0 & \rho_1 & \rho_2 & -(\mu + \delta) \end{pmatrix}.$$

Now, evaluating the Jacobian at the DFE, we obtain

$$J(E_0) = \begin{pmatrix} -\mu & -C(\omega)\frac{\Lambda}{\mu} & -C(\omega)\eta\frac{\Lambda}{\mu} & 0 \\ 0 & C(\omega)\frac{\Lambda}{\mu} - H_1 & C(\omega)\eta\frac{\Lambda}{\mu} + \sigma & 0 \\ 0 & H_2 & -H_3 & 0 \\ 0 & \rho_1 & \rho_2 & -(\mu + \delta) \end{pmatrix}.$$

It can be clearly noted that  $a_1 = -\mu$  and  $a_2 = -(\mu + \delta)$  are eigenvalues of  $J(E_0)$ . The other two eigenvalues are obtained from the non-zero roots of  $2 \times 2$  Jacobian matrix

$$J_1(E_0) = \begin{pmatrix} C(\omega)\frac{\Lambda}{\mu} - H_1 & C(\omega)\eta\frac{\Lambda}{\mu} + \sigma \\ H_2 & -H_3 \end{pmatrix}$$

with the characteristic polynomial  $P(a)$  given by

$$P(a) = a^2 + Xa + Y = 0, \tag{10}$$

where

$$X = C(\omega)\frac{\Lambda}{\mu} - (H_1 + H_3) \text{ and } Y = H_1H_3(1 - \phi)(1 - \mathcal{R}_0). \tag{11}$$

It is evident that the eigenvalues  $a_1$  and  $a_2$  have negative real parts. Similarly, according to the Routh-Hurwitz criterion, the characteristic Equation (10) has negative real eigenvalues if its coefficients are strictly positive, that is  $X > 0$  and  $Y > 0$  [2]. We note that for  $Y > 0$  then  $\mathcal{R}_0 < 1$ . Hence, the DFE is locally asymptotically stable if all the eigenvalues of the stability matrix at DFE have negative real parts. This implies that for our system, when  $\mathcal{R}_0 < 1$  and  $X > 0$  then the DFE is locally asymptotically stable and it is unstable otherwise.

Theorem 3 tells us that the HIV infection can die out slowly and end up being eliminated from the community if  $\mathcal{R}_0 < 1$ .

---

### 3.5.2 Global Stability of the DFE

**Theorem 4** *The DFE of system (3) is globally asymptotically stable whenever  $\mathcal{R}_0 < 1$  and unstable otherwise.*

*Proof* Let the candidate Lyapunov function for the global stability be given by

$$L = \psi_1 I + \psi_2 T$$

where the constants  $\psi_1$  and  $\psi_2$  are non-negative. To find these constants, we compute the time derivative of  $L$ , that is

$$\begin{aligned} \frac{dL}{dt} &= \psi_1 \frac{dI}{dt} + \psi_2 \frac{dT}{dt} \\ &\leq \psi_1 \left[ \left( \frac{C(\omega)\Lambda}{\mu} - H_1 \right) I + \left( \frac{C(\omega)\Lambda\eta}{\mu} + \sigma \right) T \right] + \psi_2 [H_2 I - H_3 T] \\ &= \left[ \psi_1 \left( \frac{C(\omega)\Lambda}{\mu} - H_1 \right) + \psi_2 H_2 \right] I + \left[ \psi_1 \left( \frac{C(\omega)\Lambda\eta}{\mu} + \sigma \right) - \psi_2 H_3 \right] T. \end{aligned} \quad (12)$$

Now equating the coefficient of the component  $T$  in (12) to zero, that is

$$\psi_1 \left( \frac{C(\omega)\Lambda\eta}{\mu} + \sigma \right) - \psi_2 H_3 = 0 \quad (13)$$

and evaluating Equation (13) for the coefficients of the Lyapunov candidate function  $L$  we get

$$\psi_1 = H_3 \quad \text{and} \quad \psi_2 = \frac{C(\omega)\Lambda\eta}{\mu} + \sigma. \quad (14)$$

Now substituting the constants  $\psi_1$  and  $\psi_2$  into Equation (12) gives

$$\begin{aligned} \frac{dL}{dt} &\leq \left[ H_3 \left( \frac{C(\omega)\Lambda}{\mu} - H_1 \right) + \left( \frac{C(\omega)\Lambda\eta}{\mu} + \sigma \right) H_2 \right] I \\ &= \left[ \frac{C(\omega)\Lambda(H_3 + \eta H_2) - \mu(H_1 H_3 - \sigma H_2)}{\mu(H_1 H_3 - \sigma H_2)} \right] (H_1 H_3 - \sigma H_2) I \\ &= H_1 H_3 (\mathcal{R}_0 - 1)(1 - \phi) I. \end{aligned}$$

Therefore, it follows that  $\frac{dL}{dt} < 0$  whenever  $\mathcal{R}_0 < 1$  and  $\frac{dL}{dt} = 0$  if and only if either  $I = 0$  or  $\mathcal{R}_0 = 1$ . The largest non-negative compact invariant subset of the set

$$\left\{ (S(t), I(t), T(t), A(t)) \in \Omega : \frac{dL}{dt} = 0 \right\}$$

if  $\mathcal{R}_0 \leq 1$  is  $E_0$ . Hence, by the LaSalle's Invariance Principle defined in [8], the DFE is globally asymptotically stable in  $\Omega$  if  $\mathcal{R}_0 < 1$ .

### 3.6 Existence of the Endemic Equilibrium

**Lemma 1** *Whenever  $\mathcal{R}_0 > 1$ , then the proposed system (3) has a unique endemic equilibrium given by*

$$E_1 = (S^*, I^*, T^*, A^*).$$

*Proof* To obtain the disease-persistent steady state of system (3) in terms of the force of infection, we set the right-hand side of system (3) to zero, that is

$$\begin{cases} \Lambda - (C(\omega)I^* + C(\omega)\eta T^* + \mu)S^* = 0, \\ (C(\omega)I^* + C(\omega)\eta T^*)S^* - H_1I^* + \sigma T^* = 0, \\ H_2I^* - H_3T^* = 0, \\ \rho_1I^* + \rho_2T^* - H_4A^* = 0, \end{cases} \quad (15)$$

where

$$H_1 = \mu + (1 - \omega)\theta + \rho_1, \quad H_2 = (1 - \omega)\theta, \quad H_3 = \mu + \sigma + \rho_2, \quad \text{and} \quad H_4 = \mu + \delta.$$

We compute the endemic equilibrium by solving system (15) simultaneously for  $S^*, I^*, T^*$  and  $A^*$ .

Now, from the third equation in the system (15), we have

$$T^* = \frac{H_2}{H_3} I^*. \quad (16)$$

Then, substituting (16) into the fourth equation of system (15) gives

$$A^* = \left( \frac{H_3\rho_1 + \rho_2H_2}{H_4H_3} \right) I^*. \quad (17)$$

Similarly, substituting (16) into the second equation of system (15), we obtain

$$I^* \left[ \left( C(\omega) + \frac{C(\omega)\eta H_2}{H_3} \right) S^* - H_1 + \frac{\sigma H_2}{H_3} \right] = 0. \quad (18)$$

Solving equation (18) for  $I^*$  and  $S^*$  gives  $I^* = 0$  which corresponds to the disease-free equilibrium or

$$S^* = \frac{H_1H_3 - \sigma H_2}{C(\omega)H_3 + C(\omega)\eta H_2} = \frac{\Lambda}{\mu\mathcal{R}_0}. \quad (19)$$

Now, substituting Equations (19) and (16) into the first equation of system (15) yields

$$I^* = \frac{\mu H_3 (\mathcal{R}_0 - 1)}{C(\omega)H_3 + C(\omega)\eta H_2}. \quad (20)$$

Substituting Equation (20) into equations (16) and (17) gives

$$T^* = \frac{\mu H_2 H_3 (\mathcal{R}_0 - 1)}{C(\omega)H_3(H_3 + \eta H_2)} \quad \text{and} \quad A^* = \left( \frac{(H_3\rho_1 + \rho_2H_2)(\mu H_3(\mathcal{R}_0 - 1))}{C(\omega)H_3H_4(H_3 + \eta H_2)} \right).$$

It can be observed that whenever  $\mathcal{R}_0 = 1$ , then the disease-persistent equilibrium becomes the disease-free equilibrium. Similarly, the results indicate that the disease-persistent equilibrium is unique and exists if and only if  $\mathcal{R}_0 > 1$ .

3.6.1 Global Stability of Endemic Steady State

**Theorem 5** *The disease-persistent equilibrium ( $E_1$ ) of system (3) is globally asymptotically stable if  $\mathcal{R}_0 > 1$ .*

*Proof* As noted earlier,  $N$  approaches  $\frac{\Lambda}{\mu}$  as  $t$  approaches  $\infty$ . So from Equation (1), we have the relation

$$S = \frac{\Lambda}{\mu} - I - T - A. \tag{21}$$

Substituting (21) into the second and third equations of system (3) yields the limiting system

$$\begin{cases} \frac{dI}{dt} = (C(\omega)I + C(\omega)\eta T) \left( \frac{\Lambda}{\mu} - I - T - A \right) - H_1I - \sigma T, \\ \frac{dT}{dt} = H_2I - H_3T. \end{cases} \tag{22}$$

Now applying the Dulac’s multiplier  $\pi_2(I, T) = \frac{1}{IT}$  as used in [11] and [15], we have

$$\begin{aligned} \partial\pi_2 &= \frac{\partial}{\partial I} \left[ \frac{(C(\omega)I + C(\omega)\eta T)}{IT} \left( \frac{\Lambda}{\mu} - I - T - A \right) - \frac{H_1}{T} + \frac{\sigma}{I} \right] + \frac{\partial}{\partial T} \left[ \frac{H_2}{T} - \frac{H_3}{I} \right] \\ &= \frac{\partial}{\partial I} \left[ -\frac{C(\omega)}{T} + \frac{C(\omega)\eta\Lambda}{I\mu} - \frac{C(\omega)\eta T}{I} - \frac{C(\omega)\eta A}{I} + \frac{\sigma}{I} \right] + \frac{\partial}{\partial T} \left[ \frac{H_2}{T} \right] \\ &= -\frac{C(\omega)}{T} - \frac{C(\omega)\eta\Lambda}{\mu I^2} + \frac{C(\omega)\eta T}{I^2} + \frac{C(\omega)\eta A}{I^2} - \frac{\sigma}{I^2} - \frac{H_2}{T^2} \\ &= -\left[ \frac{C(\omega)}{T} + \frac{C(\omega)\eta}{I^2} \left( \frac{\Lambda}{\mu} - (T + A) \right) + \frac{\sigma}{I^2} + \frac{H_2}{T^2} \right]. \end{aligned}$$

We note that  $\partial\pi_2 < 0$  since  $\frac{\Lambda}{\mu} \geq (T + A)$  in  $\Omega$ . Therefore, by the Dulac’s criterion, no closed or periodic orbits exist in  $\Omega$ . Then, according to the Poincare-Bendixon Theorem, all the solutions of system (22) starting in  $\Omega$  remain in  $\Omega$  for all time  $t$ , since the endemic steady state exists if  $\mathcal{R}_0 > 1$  and  $\Omega$  is positively invariant [17]. Additionally, having no periodic orbits in  $\Omega$  means that the unique disease-persistent steady state of system (3) is globally asymptotically stable if  $\mathcal{R}_0 > 1$ .

**4 Results & Discussion**

In this section, we present results of the simulations for system (3). We will estimate parameter values and hypothetically choose the initial population values. We will carry out sensitivity analysis to identify model parameters that highly influence the reproduction number  $\mathcal{R}_0$ . We will also solve system (3) for DFE and disease-persistent equilibrium to support the analytic results. We will also look at the effect of selected parameters to the reproduction number  $\mathcal{R}_0$ .

### 4.1 Estimation of Parameter Values

We need to determine the values of model parameters to carry out numerical simulations in order to draw vital information and insights from the system. To begin with, we estimate the values of parameters basing on the existing literature which agrees with biological facts and experimental data.

The rate at which individuals are recruited into the susceptible class is approximated to be  $\Lambda = 0.02N$  and natural death rate to be  $\mu = \frac{1}{63}$ . Table 2 below shows the estimated values for the other parameters of system (3).

Parameter	Estimate value/year	Source
$\delta$	0.09	Estimated
$\omega$	$0 \leq \omega \leq 1$	Estimated
$\theta$	$0 \leq \theta \leq 1$	Estimated
$\rho_1$	0.1	Estimated
$\rho_2$	0.05	Estimated
$\sigma$	$0 \leq \sigma \leq 1$	Estimated
$\eta$	$0 \leq \eta \leq 1$	Estimated
$\varepsilon$	7	Estimated
K	9	Estimated
$\beta_{max}$	$0.000000001 \leq \beta_{max} \leq 0.00000001$	Estimated

**Table 2** Estimation of parameter values for system (3).

### 4.2 Sensitivity Analysis

Sensitivity analysis is a technique that is used to determine how epidemiological quantities such as disease prevalence and reproduction number respond to variations in parameter values. For instance, through sensitivity analysis we can tell which parameters have high effect on reproduction number and target them to reduce HIV transmission. It is crucial to evaluate the robustness of the system predictions to the estimated parameter values through sensitivity analysis since the approximation of parameters were associated with uncertainties. The model parameters which are most sensitive to the reproduction number contribute largely to the spread of the disease. Therefore, carrying out sensitivity or uncertainty analysis can help in identifying the parameters to target in the intervention strategies since it provides information on the role played by different parameter values in the dynamics of HIV epidemic.

We employ the concept of elasticity (normalized sensitivity index) to examine the sensitivity of  $\mathcal{R}_0$  with respect to changes in its parameters as described in [3], [6], [18], [16] and [15]. It is important to note that the higher the absolute values of the sensitivity index of  $\mathcal{R}_0$  with respect to the parameter, the more the impact that the parameter has on  $\mathcal{R}_0$ .

**Definition 1** If  $\mathcal{R}_0$  is differentiable with respect to each of its parameters, then the expression for normalized sensitivity index ( $S_{\xi}^{\mathcal{R}_0}$ ) of  $\mathcal{R}_0$  to the parameter  $\xi$ , is given by

$$S_{\xi}^{\mathcal{R}_0} = \frac{\partial \mathcal{R}_0}{\partial \xi} \times \frac{\xi}{\mathcal{R}_0}. \tag{23}$$

Note that  $\frac{\xi}{\mathcal{R}_0}$  is introduced to make resultant value of  $S_{\xi}^{\mathcal{R}_0}$  unitless.

Additionally, in (23) we assume that the contribution of partial derivatives of higher order are negligible and no correlation exist between the parameters. Now applying the explicit sensitivity index formula provided in (23) with model parameters values given in Table 2, we get sensitivity indices for each parameter in  $\mathcal{R}_0$  which are shown in Table 3.

Parameter	Sensitivity index
$\mu$	-1.1385
$\omega$	+1.1031
$\Lambda$	+1.0000
$\beta_{max}$	+1.0000
$\varepsilon$	+0.9651
$K$	-0.6894
$\theta$	-0.5520
$\rho_2$	-0.3001
$\rho_1$	-0.2724
$\sigma$	+0.2631
$\eta$	+0.1324

**Table 3** Sensitivity indices of  $\mathcal{R}_0$

The sensitivity indices in Table 3 are arranged according to their magnitude (absolute values) in a descending order. Similarly, it is important to note that increasing the model parameters with the positive and negative sensitivity indices increase and decrease the reproduction number  $\mathcal{R}_0$  respectively.

We can observe from Table 3 that the most sensitive parameters to  $\mathcal{R}_0$  are level of interference  $\omega$ , recruitment rate  $\Lambda$  and contact rate  $\beta_{max}$ . For  $\omega = +1.1031$  implies that a 11.031% increase (decrease) in  $\omega$  causes  $\mathcal{R}_0$  to increase (decrease) by the same rate. Similarly,  $\Lambda = +1.0000$  and  $\beta_{max} = +1.0000$  tells us that a 10% increase (decrease) in  $\Lambda$  and  $\beta_{max}$  makes  $\mathcal{R}_0$  to increase (decrease) by 10%. The sensitivity analysis results indicate that  $\mathcal{R}_0$  increases with increase in  $\omega$ . We can also observe that as we increase the rate of treatment  $\theta$ ,  $\mathcal{R}_0$  also decreases. From the given model parameters, we focus on  $\theta$ ,  $\sigma$  and  $\eta$  and we can observe that the disease progression can be lowered by increasing the rate of treatment  $\theta$ , reducing drop out rate  $\sigma$  and ensuring that treatment is very effective by lowering the value of  $\eta$ .

### 4.3 Simulations Results

In this section, we use Matlab to solve system (3) and simulate the results to verify theoretical conclusions. We also vary the parameters to understand the impact of treatment on HIV transmission dynamics in presence of interference. For illustrative purposes, we consider a hypothetical total population of 18200000 individuals, with the initial conditions  $S(0) = 12000000, I(0) = 650000, T(0) = 5500000$  and  $A(0) = 50000$ .

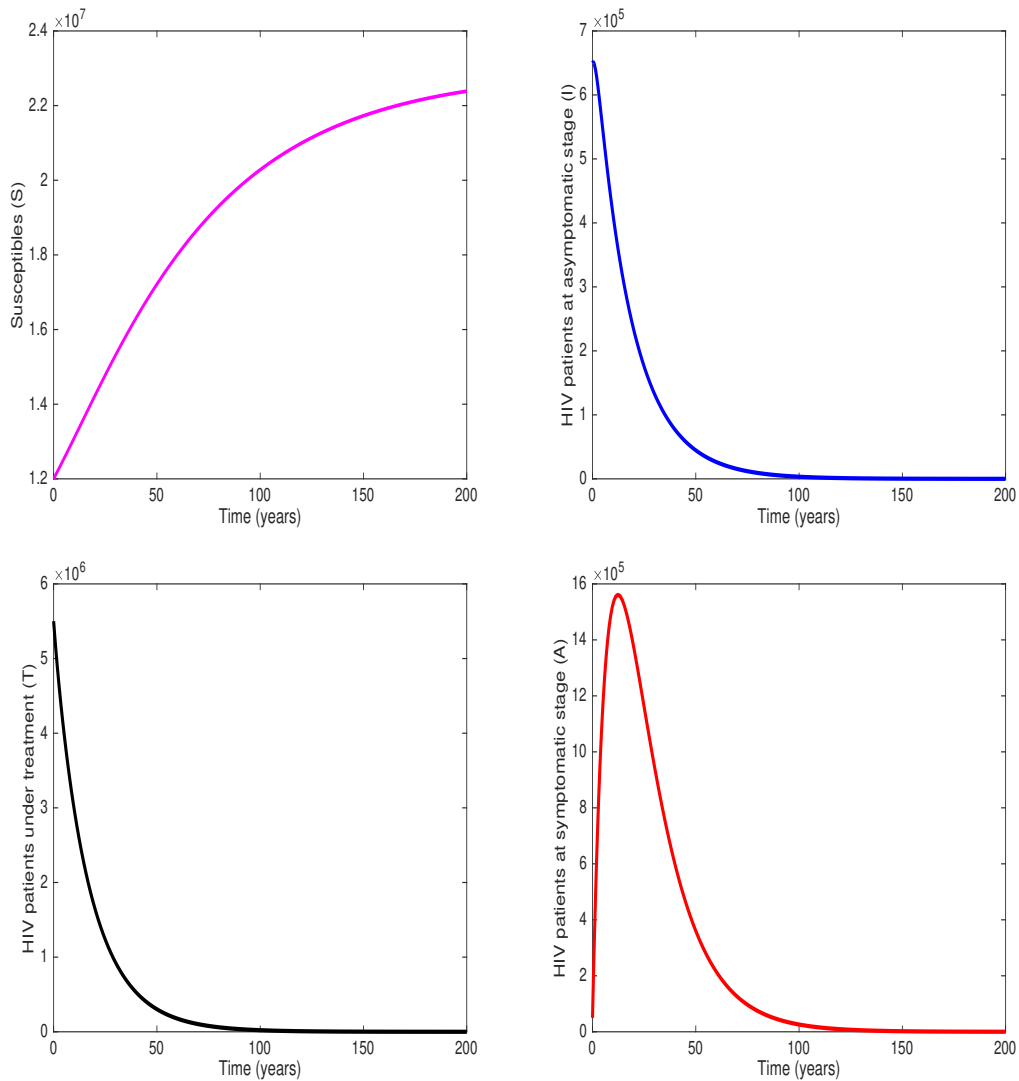

**Fig. 3** Indicates the results of simulations at *DFE* for the following values of parameters:  $\Lambda = 364000, \mu = \frac{1}{63}, \omega = 0.2, \theta = 0.6, \sigma = 0.06, \eta = 0.04, \rho_1 = 0.1, \rho_2 = 0.05, K = 9, \varepsilon = 7, \delta = 0.09$  and  $\beta_{max} = 0.00000002$ . Here, the value of the reproduction number is  $\mathcal{R}_0 = 0.4473$ .

Figure 3 shows that the disease can be eliminated from the entire population after sometime when  $\mathcal{R}_0 < 1$ . The population of HIV-infected individuals (*I*), infected individuals under treatment (*T*) and those in full-blown AIDS stage will all decline to zero with time. On the contrary, we can observe that the susceptible population *S* keeps increasing with time until it approaches a constant value of  $\frac{\Lambda}{\mu}$ . This is consistent with the theoretical results that we obtained in stability analysis. We observe that HIV infection may die out in approximately 100 years if appropriate control measures that ensure that the reproduction number ( $\mathcal{R}_0$ ) is kept below unity are undertaken.

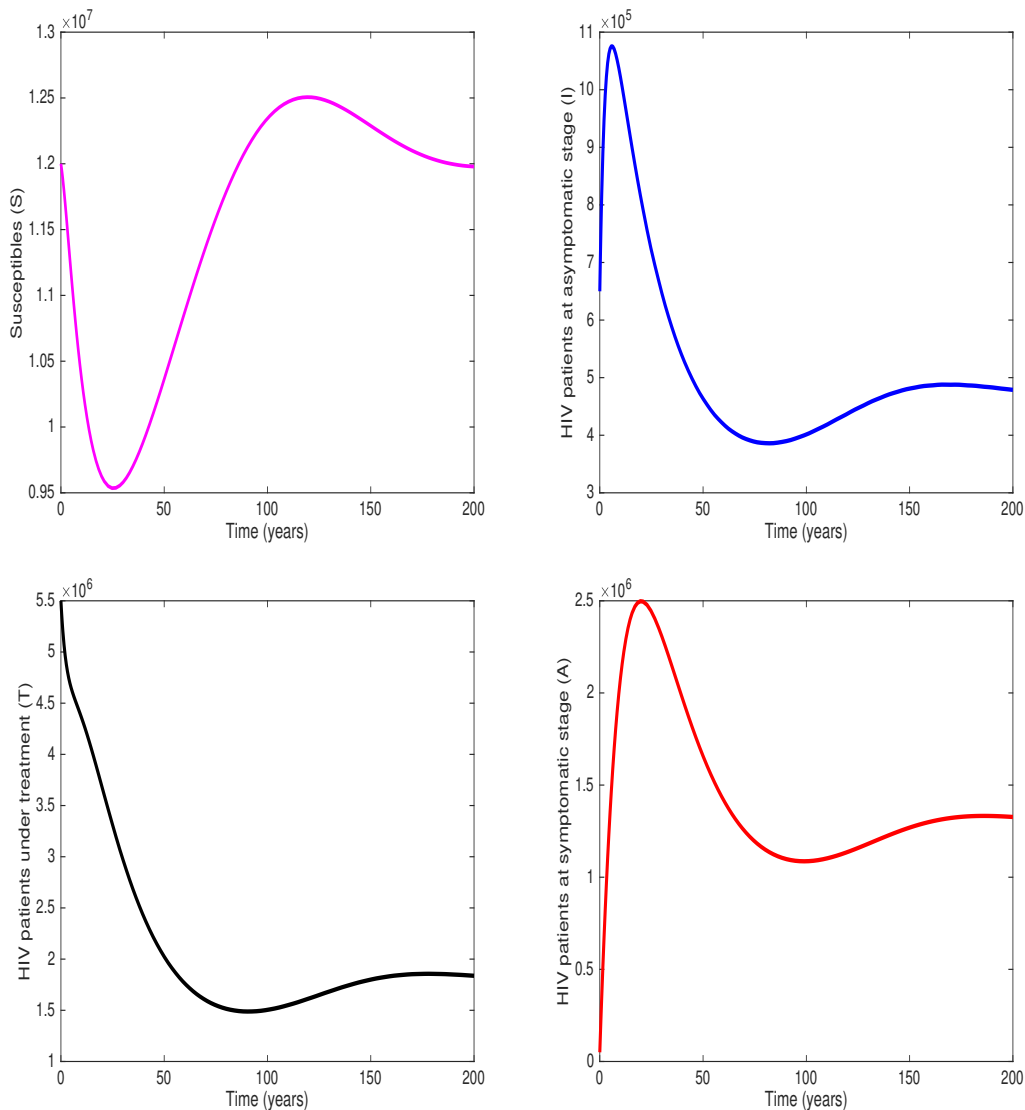
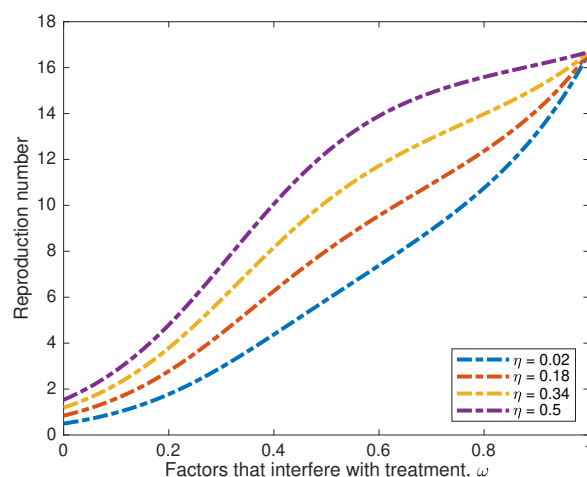

**Fig. 4** Shows the result of simulations for the following values of parameters:  $\Lambda = 364000$ ,  $\mu = \frac{1}{63}$ ,  $\omega = 0.2$ ,  $\theta = 0.6$ ,  $\sigma = 0.06$ ,  $\eta = 0.04$ ,  $\rho_1 = 0.1$ ,  $\rho_2 = 0.05$ ,  $K = 9$ ,  $\varepsilon = 7$ ,  $\delta = 0.09$  and  $\beta_{max} = 0.000000085$ . Here, the value of the reproduction number  $\mathcal{R}_0 = 1.9010$  is greater than one.

The graphical representation in Figure 4 also concurs with our stability analysis results. We observe that initially there is a short-term increase in the population of HIV patients at asymptomatic stage ( $I$ ) and infected individuals at AIDS stage ( $A$ ), but after sometime all compartments with the infection decline and stabilizes at different heights. This indicates that system (3) levels off at disease-persistent steady state as stipulated in Theorem 5. Therefore, the HIV epidemic persists in the community when  $\mathcal{R}_0 > 1$  hence verifying the fact that the disease-persistent equilibrium is globally asymptotically stable when  $\mathcal{R}_0 > 1$ .

#### 4.4 Impact of Model Parameters on the Reproduction Number $\mathcal{R}_0$

It is important to investigate how the reproduction number is influenced by some changes in the selected model parameters since it provides vital information regarding the spread of the infection. To start with, we fix all the other model parameter values and vary the reproduction number  $\mathcal{R}_0$  with the factors that hinder interventions for different values of the relative infectivity of  $T$  with respect to  $I$  as shown in Figure 5.



**Fig. 5** Evolution of  $\mathcal{R}_0$  against the level of interference  $\omega$  for the following values of parameters:  $\Lambda = 364000, \mu = \frac{1}{63}, \omega = 0.2, \theta = 0.6, \sigma = 0.06, \rho_1 = 0.1, \rho_2 = 0.05, K = 9, \varepsilon = 7, \delta = 0.09, \beta_{max} = 0.000000085$  with four values of  $\eta$ , 0.02, 0.18, 0.34, and 0.5.

Figure 5 highlights some very interesting results on the relationship between the reproduction number  $\mathcal{R}_0$  and the level of interference  $\omega$  for different values of  $\eta$ . We can observe that if treatment is very effective in reducing the infection, that is for low values of  $\eta$ , then the rate at which  $\mathcal{R}_0$  increases is lower as compared to higher values of  $\eta$ . Therefore, we can note that even with increased interference, as long as treatment is effective the disease progression is low. However, if treatment has a low impact to disease transmission then increased interference has increased propensity to raise the value of  $\mathcal{R}_0$ . So we need an effective treatment regime even if the interference is high.

Figure 6 provides crucial information about the impact of interference on disease progression for different values of drop out rate  $\sigma$ . If treatment is effective, we note that if drop out rate is increased, the reproduction number also increases. So, a reduction in the number of drop out cases is essential even in the presence of interference. On the contrary, if  $\eta$  is high indicating that the treatment is less effective then the changes in the rates of drop out does not significantly change the growth of  $\mathcal{R}_0$  as the factors that hinder interventions increase, in fact  $\mathcal{R}_0$  increases significantly even with low drop out rates as shown in Figure 7. Therefore, effective treatment (low value of  $\eta$ ) is essential in the fight against HIV even in the presence interference.

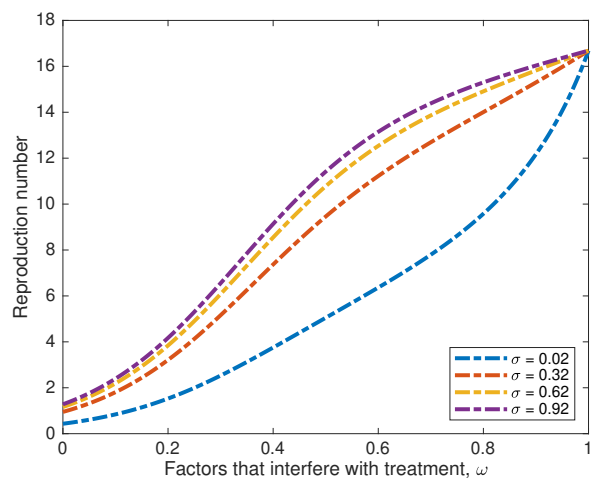

**Fig. 6** Evolution of  $\mathcal{R}_0$  against the level of interference  $\omega$  for the following values of parameters:  $\Lambda = 364000, \mu = \frac{1}{63}, \omega = 0.2, \theta = 0.6, \sigma = 0.06, \eta = 0.04, \rho_1 = 0.1, \rho_2 = 0.05, K = 9, \varepsilon = 7, \delta = 0.09, \beta_{max} = 0.000000085$  with four values of  $\sigma$ , 0.02, 0.32, 0.62, and 0.92.

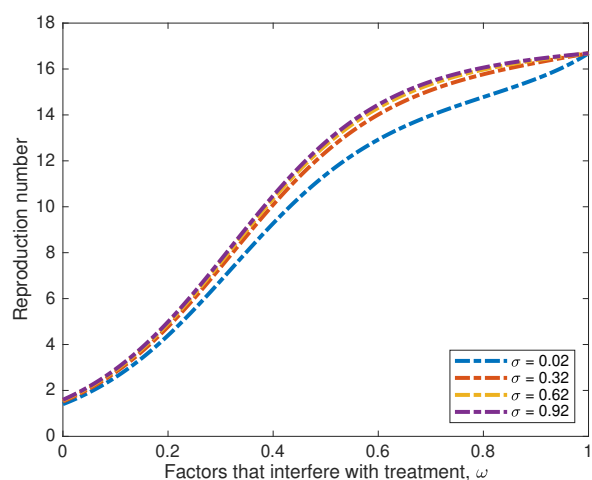

**Fig. 7** Evolution of  $\mathcal{R}_0$  against the level of interference  $\omega$  for the following values of parameters:  $\Lambda = 364000, \mu = \frac{1}{63}, \omega = 0.2, \theta = 0.6, \sigma = 0.06, \eta = 0.45, \rho_1 = 0.1, \rho_2 = 0.05, K = 9, \varepsilon = 7, \delta = 0.09, \beta_{max} = 0.000000085$  with four values of  $\sigma$ , 0.02, 0.32, 0.62, and 0.92.

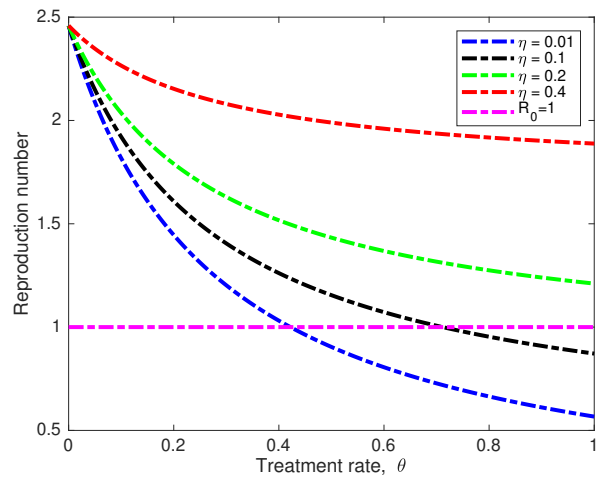

**Fig. 8** Evolution of  $\mathcal{R}_0$  against the treatment rate  $\theta$  for the following values of parameters:  $\Lambda = 364000, \mu = \frac{1}{63}, \omega = 0.2, \sigma = 0.06, \eta = 0.45, \rho_1 = 0.1, \rho_2 = 0.05, K = 9, \varepsilon = 7, \beta_{max} = 0.00000004$  with four values of  $\eta$ , 0.01, 0.1, 0.2, and 0.4.

Figure 8 shows that when  $\eta = 0.01$  and  $\eta = 0.1$  then we need treatment rates to be above 0.45 and 0.75 respectively for its effect to be essential in stopping the epidemic from spreading in the population. In addition, the graphical representation also illustrates that the disease progression decreases at a lower rate when  $\eta$  is high. Therefore, treatment is effective in controlling new infections but it may not halt transmission of the virus when  $\eta$  is high.

To get a better understanding on how the rate of treatment, level of interference and drop out rates impact the reproduction number  $\mathcal{R}_0$ , we plot contours which show how  $\mathcal{R}_0$  changes with two parameters simultaneously.

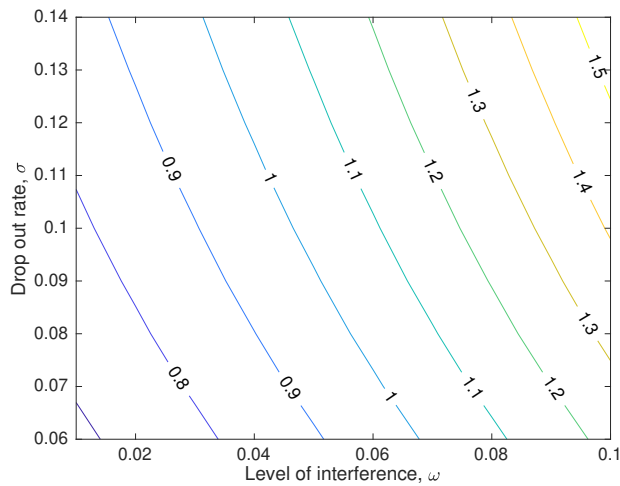

**Fig. 9** The diagram shows how the drop out rate parameter  $\sigma$ , and the interference level parameter  $\omega$ , influences the reproduction number  $\mathcal{R}_0$  for the following parameter values:  $\Lambda = 364000, \mu = \frac{1}{63}, \theta = 0.4, \eta = 0.04, \rho_1 = 0.1, \rho_2 = 0.05, K = 9, \varepsilon = 7, \beta_{max} = 0.00000008$ .

Figure 9 illustrates the relationship between interference level and the drop out rates. We can note from the graphical representation that as the interference level and drop out rate increase then  $\mathcal{R}_0$  also increases. The disease progresses much faster when both the level of interference and drop out rates are high. Therefore, if treatment is effective as indicated by the value of  $\eta$  then it is important to minimize the drop out cases as much as possible even in the presence of interference.

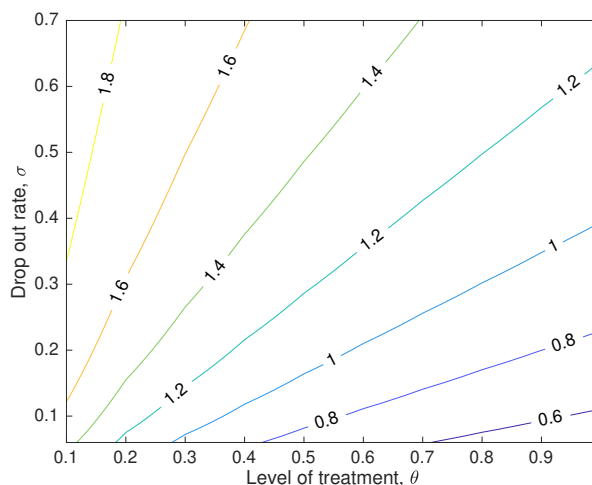

**Fig. 10** Contour plot showing how the drop out rate parameter  $\sigma$ , and the treatment rate parameter  $\theta$ , influences the reproduction number  $\mathcal{R}_0$ , for the following parameter values:  $\Lambda = 364000, \mu = \frac{1}{63}, \omega = 0.03, \eta = 0.04, \rho_1 = 0.1, \rho_2 = 0.05, K = 9, \varepsilon = 7, \beta_{max} = 0.000000085$ .

Figure 10 indicates that increasing the treatment rate has greater potential to lower disease progression since  $\mathcal{R}_0$  values decrease much faster than the rate of treatment increase. The graphical description also suggests that a reduction of the drop out rate will only be effective if treatment is also effective. Therefore, our graphical simulation results reiterate the significance of very effective treatment regime even in the presence of interference to reduce the proliferation of HIV infection.

### 5 Conclusion

In this paper, we proposed and analysed a mathematical model for HIV to further understand the HIV infection dynamics in the presence of interference. We discussed the mathematical features of the system which include: boundedness and positivity of solutions, threshold value of HIV epidemic and stability of the equilibria states. We determined the basic properties of the model and proved that all solutions of the system are non-negative and bounded. We also noted that the reproduction number of the model has two components, namely; the contribution of infected individuals not in treatment,  $\mathcal{R}_I$  and that of infected individuals under medication,  $\mathcal{R}_T$ .

We used an appropriate Lyapunov candidate function and LaSalle invariance principle to establish the global stability of the disease-free equilibrium. We found that when the threshold value of the epidemic is less than unity, that is, when  $\mathcal{R}_0 < 1$ , then the disease-free steady state of the system is locally and globally attractive. This implies that when  $\mathcal{R}_0 < 1$ , then the cases of new HIV infections generated is less than the

---

number of infected individuals spreading the disease meaning that the epidemic can be eliminated from the community. Therefore, HIV/AIDS pandemic can be controlled effectively if intervention strategies are targeted towards minimizing the value of  $\mathcal{R}_0$  to less than unity. However, whenever  $\mathcal{R}_0 > 1$ , the disease-free equilibrium becomes unstable. In addition, we showed that the system has a unique disease-persistent equilibrium which is globally asymptotically stable whenever  $\mathcal{R}_0 > 1$ .

Moreover, we observed that presence of interference fuels the spread of HIV/AIDS and a worst case scenario may be experienced when the level of interference is high and the drop out rate from treatment is high. We investigated the effect of model parameters on  $\mathcal{R}_0$  and found that interference has the effect of reducing the uptake of treatment and increasing the rate of treatment drop-out. Therefore, scaling-up effective HIV treatment and lowering drop out rates even in presence of interference is crucial in reducing onward transmission of HIV/AIDS infection.

## 6 Future Scope

We acknowledge that the presented model has some shortfalls. For instance, consideration of treatment alone as a control mechanism for HIV infection. Inclusion of more controls such as HIV screening as well as other educational programs will definitely enhance the understanding of the HIV/AIDS pandemic. Furthermore, taking into account other HIV transmission routes like mother-to-child during birth or breastfeeding, infected blood transfusions, sharing piercing equipment with infected individuals will provide more information regarding the transmission of HIV. Nevertheless, the results obtained from the proposed model provide adequate insights into the dynamics of HIV and lays the foundation for the understanding of the role of interference in the HIV disease dynamics.

---

**References**

1. Birger, R. B., Hallett, T. B., Sinha, A., Grenfell, B. T., and Hodder, S. L. (2013). Modeling the impact of interventions along the HIV continuum of care in Newark, New Jersey. *Clinical Infectious Diseases*, 58(2):274–284.
2. DeJesus, E. X. and Kaufman, C. (1987). Routh-hurwitz criterion in the examination of eigenvalues of a system of nonlinear ordinary differential equations. *Physical Review A*, 35(12):5288.
3. Hamby, D. (1994). A review of techniques for parameter sensitivity analysis of environmental models. *Environmental Monitoring and Assessment*, 32(2):135–154.
4. Huo, H.-F. and Chen, R. (2015). Stability of an HIV/AIDS treatment model with different stages. *Discrete Dynamics in Nature and Society*.
5. Januaris Saint Fores (2018) (Accessed April 2019). 10 major factors that contribute to the spread of HIV/AIDS in the developing world. <https://owlcation.com/stem/What-Factors-Contribute-to-the-Spread-of-HIVAIDS-in-Kenya>.
6. Kalula, A. S. (2011). *Modelling the dynamics of methamphetamine abuse in the Western Cape*. PhD thesis, Stellenbosch: University of Stellenbosch.
7. Kim, S. B., Yoon, M., Ku, N. S., Kim, M. H., Song, J. E., Ahn, J. Y., Jeong, S. J., and Kim (2014). Mathematical modeling of hiv prevention measures including pre-exposure prophylaxis on hiv incidence in south korea. *PLoS One*.
8. LaSalle, J. P. (1976). *The stability of dynamical systems*, volume 25. Siam.
9. Luo, S., Han, L., Lu, H., Dou, Z., Tao, Q., Khoshnood, K., Wu, Z., and Xu, J. (2015). Evaluating the impact of test-and-treat on the HIV epidemic among MSM in China using a mathematical model. *Public Library of Science*, 10(6):e0126893.
10. Malunguza, N., Mushayabasa, S., Chiyaka, C., and Mukandavire, Z. (2010). Modelling the effects of condom use and antiretroviral therapy in controlling HIV/AIDS among heterosexuals, homosexuals and bisexuals. *Computational and Mathematical Methods in Medicine*, 11(3):201–222.
11. Mukandavire, Z., Gumel, A. B., Garira, W., and Tchuenche, J. M. (2009). Mathematical analysis of a model for HIV-Malaria co-infection.
12. Nyabadza, F., Mukandavire, Z., and Hove-Musekwa, S. (2011). Modelling the HIV/AIDS epidemic trends in South Africa: Insights from a simple mathematical model. *Nonlinear Analysis: Real World Applications*, 12(4):2091–2104.
13. Okosun, K., Makinde, O., and Takaidza, I. (2013). Impact of optimal control on the treatment of HIV/AIDS and screening of unaware infectives. *Applied Mathematical Modelling*, 37(6):3802–3820.
14. Omondi, E., Mbogo, R., and Luboobi, L. (2018a). Mathematical analysis of sex-structured population model of HIV infection in Kenya. *Letters in Biomathematics*, 5(1):174–194.
15. Omondi, E., Mbogo, R. W., and Luboobi, L. (2018b). Mathematical modelling of the impact of testing, treatment and control of HIV transmission in Kenya. *Cogent Mathematics Statistics*, 5(1):1475590.
16. Omondi, E. O., Orwa, T. O., and Nyabadza, F. (2018c). Application of optimal control to the Onchocerciasis transmission model with treatment. *Mathematical Biosciences*, 297:43–57.
17. Perko, L. (2013). *Differential equations and dynamical systems*. Springer Science & Business Media.
18. Rodrigues, H. S., Monteiro, M. T. T., and Torres, D. F. (2013). Sensitivity analysis in a dengue epidemiological model. In *Conference Papers in Science*. Hindawi.
19. Safiel, R., Massawe, E. S., and Makinde, O. (2012). Modelling the effect screening and treatment on transmission of HIV/AIDS infection in a population. *American Journal of Mathematics and Statistics*, 2(4):75–88.
20. Su, Z., Dong, C., Li, P., Deng, H., Gong, Y., Zhong, S., Wu, M., Ruan, Y., Qin, G., Yang, W., et al. (2016). A mathematical modeling study of the HIV epidemics at two rural townships in the Liangshan Prefecture of the Sichuan Province of China. *Infectious Disease Modelling*, 1(1):3–10.

- 
21. Thiébaud, R. and May, M. T. (2013). Mathematical modelling of HIV prevention intervention. *AIDS*, 27(3):475–476.
  22. UNAIDS (2018) (Accessed April 2019). UNAIDS DATA 2018. UNAIDS, [https://www.unaids.org/sites/default/files/media\\_asset/unaids-data-2018\\_en.pdf](https://www.unaids.org/sites/default/files/media_asset/unaids-data-2018_en.pdf).
  23. Van den Driessche, P. and Watmough, J. (2002). Reproduction numbers and sub-threshold endemic equilibria for compartmental models of disease transmission. *Mathematical Biosciences*, 180(1-2):29–48.
  24. WHO (2018) (Accessed April 2019). HIV/AIDS-Global Health Observatory (GHO) data. <http://www.who.int/gho/hiv/en/>.