Containing 2019-nCoV Through Social Distancing

Abstract

2019-nCoV/SARS-CoV2 is a highly pathogenic human corona virus transmitted by respiratory droplets with an incubation period of 2-14 days. It is both a public health and economic threat worldwide. In this study, a deterministic mathematical model based on systems of ordinary differential equations for the dynamics of 2019-nCoV/SARS-CoV2 transmission incorporating social distancing as a control measure has been derived. The steady states have also been analysed for stability using the basic reproduction number. Numerical simulations carried out using MATLAB R2021b shows that social distancing intervention is key to reduction in the infection rate of 2019-nCoV/SARS-nCoV2. The study recommends implementation of public policies on public gatherings such as political rallies, worship centers, market places, football matches to curb the potential chain transmission in a pandemic contagion.

Keywords: Basic Reproduction Number, Lyapunov Functions, Global Stability, Mathematical Modeling
2010 Mathematics Subject Classification: 34C60,34D23; 37B25; 92B05,97M60

1 Introduction

Coronavirus belongs to *Nidovirales* order which include Coronaviridae, Arteriviridae and Roniviridae. Nidovirales order are enveloped, non-segmented positive-sense RNA viruses. Coronaviridae has the largest identified RNA genome, [Fehr and Perlman (2016)] According to [Lee et al (2003); Donglai et al (2005)], Severely Acute Respiratory Syndrome (SARS) first appeared in Guangdong, China, in November 2002. This epidemic spread rapidly in the winter of 2003-2004 to many parts of the world, making it the first major disease outbreak of the 21st century.

SARS associated Coronavirus (SARS-CoV) was identified by [Donnelly et al (2003)] as the etiological (causal) agent of SARS. Prior to SARS-CoV outbreak, Coronaviruses were only thought to cause mild self limiting respiratory infections in human. These viruses were assumed to be endemic in human populations and was evidently more severe in neonates, elderly and individuals with underlying health

conditions. Moreover SARS-CoV transmission was relatively inefficient since it could only be spread through contact with infected individual after the onset of illness. The outbreak was largely contained within households and health care settings, [Peiris et al (2003)]. An individual could only super-spread the virus through multiple contacts due to enhanced developments of high viral burden, ability to aerosolize the virus or due to compromised immune system[Anita and Jerigan (2020); Fehr and Perlman (2016)].

Later in the decade a highly pathogenic human Coronavirus (HCoV) called Middle East Respiratory Syndrome (MERS-CoV) emerging from animal reservoir with high mortality was also identified,[Zhou et al (2020)].Most recently, another highly pathogenic human coronavirus (HCoVs) named 2019 novel Coronavirus (2019-nCoV/SARS-CoV2)has been identified as the etiological agent of coronavirus disease 2019 abbreviated as COVID 19. This disease was first reported in Wuhan city, China, in December, 2019,[Chen et al (2020)].Viruses such as the human coronavirus (HCoV) require host cellular factors for successful replication during infection [Zumla et al (2016)], hence systematic identification of virus-host protein-protein interaction offer an effective way of eliminating viral infection including SARS-CoV, MERS-CoV and 2019-nCoV. Signs and symptoms of patients with 2019-nCoV infection includes fever, cough and shortness of breath. Based on the incubation of MERS-CoV and SARS which are transmitted by respiratory droplets, [Anita and Jerigan (2020)] reiterates that COVID 19 occurs within 2-14 days. 2019-nCoV has impacted countries worldwide causing severe illness and its human to human transmission makes it a public health and economic threat. Owing to the lack of effective therapeutics or vaccines, stringent public health surveillance systems like identification of cases from high risk countries coupled with rapid diagnostic testing, social distancing and quarantine during an outbreak,[Fehr and Perlman (2016)] should be implemented to curb the potential chain transmission of human coronavirus like this deadly 2019-nCoV.

Transmission of infectious diseases is of great interest to both medics and scholars, [Yao and Liang (2015)]. Public health programmes such as isolation,quarantine,social distancing awareness are strategic in prevention, control and containing an epidemic can subsequently impact the rate of disease transmission in an epidemic contagion,[Huo and Wang (2020)].

Mathematical models of COVID 19 have attempted to study both the epidemiological and dynamical aspects of the disease,[Anita and Jerigan (2020); Chowel et al (2014); Kucharski et al (2020); Kiesha al (2020); Qianying et al (2018); Tiamu et al (2020); Zhou et al (2020)]. From epidemiological perspective, the mathematical models have been used to determine the basic reproduction number [Kiesha al (2020); Tiamu et al (2020)].Other models have been to estimate the effectiveness of information during the outbreak[Kiesha al (2020)]. The specific dynamics of the disease has also been done by [Kucharski et al (2020)]. This study proposes formulation of a mathematical model of 2019 nCoV with Social Distancing as a Control Measure.

2 Objective

In this paper, we

1. Formulate a Mathematical model for 2019-nCoV transmission incorporating social distancing as a control measure.
2. Perform stability analysis of the formulated model

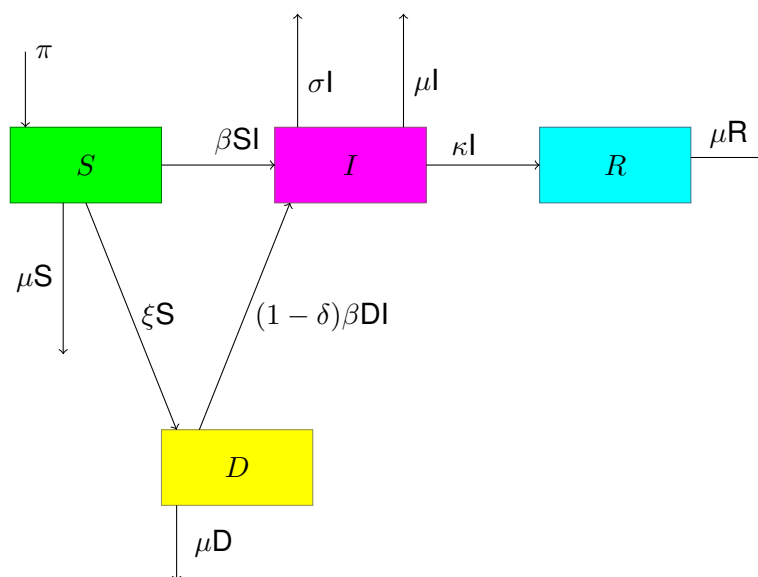

Figure 1: The flow chart showing dynamics of 2019-nCoV Transmission and Control

3 Model

This study proposes a deterministic model based on system of ordinary differential equations for the dynamics of 2019-nCoV transmission, incorporating social distancing as a control strategy. The total population at any time t , $N(t)$ is subdivided into 4 compartments: Susceptible $S(t)$ in which all individuals are susceptible to 2019-nCoV, Social distancing compartment $D(t)$, in which individuals are aware about through social distancing as a control and other prevention measures. $I(t)$ is the compartment in which individuals are infected by 2019-nCoV and Recovered compartment $R(t)$ in which all individuals have recovered after treatment. Because of the short incubation and assuming that the probability of survival till infectious state for exposed individuals to 2019-nCoV is unity and therefore excluding the exposure stage. The removed class comprises of those who who have been removed from scene of infection by means of infection-acquired immunity and death

The human population is not assumed to be constant since birth, migration, immigration and death occur. The recruitment into S susceptible population takes place at the rate $\Lambda N = \pi$. Natural death rate occurs in S, D, I and R classes at a rate μ . Infected individuals again suffer death rate due to disease at the rate σ . The rate at which susceptible observe social distance is represented by ξ where $0 < \xi < 1$. Individuals in a susceptible class may acquire infection from infected environment or from infected humans and move to compartment I at the rate βSI where β is the effective contact rate for the disease transmission. Observation of social distance may not be very effective due to search of basic human needs like food so the individuals in class D may be infected at the rate $(1 - \delta)\beta DI$ where δ is the success rate of observation of social distancing and $(1 - \delta)$ is the failure rate of observation of social distancing. Individuals in I recover at the rate κ

From the above definitions and variables description of flow chart in figure 1 we have the following

model with non-negative initial conditions

$$\begin{aligned}
 \frac{dS}{dt} &= \pi - \beta SI - \mu S - \xi S \\
 \frac{dD}{dt} &= \xi S - \mu D - (1 - \delta)\beta DI \\
 \frac{dI}{dt} &= \beta SI + (1 - \delta)\beta DI - (\sigma + \mu + \kappa)I \\
 \frac{dR}{dt} &= \kappa I - \mu R
 \end{aligned} \tag{3.1}$$

3.1 Positivity of Solutions

Assuming the initial condition of the system (3.1) to be non-negative

$$S(0) = S_0 \geq 0, \quad D(0) = D_0 \geq 0, \quad I(0) = I_0 \geq 0, \quad R(0) = R_0 \geq 0$$

Consider the first equation of the model system (3.1) at time t

$$\frac{dS}{dt} = \pi - \beta SI - \mu S - ES$$

implying that

$$\begin{aligned}
 \frac{dS}{dt} &\geq -\beta SI - \mu S - \xi S \\
 \frac{dS}{dt} &\geq -(\beta I + \mu + \xi)S
 \end{aligned}$$

integrating

$$\int \frac{dS}{S} \geq -\int (\beta I + \mu + \xi) dt$$

to obtain

$$\ln S \geq -[\beta \int I(t) + \mu(t) + \xi(t)] + \ln c_1 \quad \text{at } t = 0 \text{ and } \ln c_1 = \ln S_0$$

so that we have

$$\ln \left(\frac{S(t)}{S_0} \right) \geq -\mu t - \xi t - \beta \int I(t) dt$$

Taking exponentials of both sides

$$S(t) \geq S_0 e^{-(\mu + \xi)t - \beta \int I(t) dt}$$

Therefore the first equation of the system (3.1) is positive for all $t > 0$, since $e^t > 0$ for all $t \in \mathbb{R}$

For the second equation

$$\frac{dD}{dt} = \xi S - \mu D - (1 - \delta)\beta DI$$

This implies

$$\frac{dD}{dt} \geq -\mu D - (1 - \delta)\beta DI \geq -(\mu + (1 - \delta)\beta I)D$$

separating variables and integrating

$$\int \frac{dD}{D} \geq - \int (\mu + (1 - \delta)\beta I) dt$$

we obtain

$$\ln D(t) \geq -\mu t - \int (1 - \delta)\beta I(t) dt + \ln c_2 \quad \text{at } t = 0, \text{ and } \ln c_2 = \ln D_0$$

gives

$$\ln \left(\frac{D(t)}{D_0} \right) \geq -\mu t - \int (1 - \delta)\beta I(t) dt$$

Taking exponentials on both sides

$$\frac{D(t)}{D_0} \geq e^{-\mu t - \int (1 - \delta)\beta I(t) dt}$$

which equivalently be written as

$$D(t) \geq D_0 e^{-\mu t - \int (1 - \delta)\beta I(t) dt}$$

Therefore the second equation of the system (3.1) is also positive for all $t > 0$ since $e^t > 0$ for all $t \in \mathbb{R}$

In the third equation of the system (3.1)

$$\frac{dI}{dt} = \beta SI + (1 - \delta)\beta DI - (\mu + \kappa + \sigma)I$$

implying

$$\frac{dI}{dt} \geq -(\mu + \kappa + \sigma)I$$

separating the variables and integrating

$$\int \frac{dI}{I} \geq - \int (\mu + \kappa + \sigma) dt$$

yields

$$\ln I(t) \geq -(\mu + \kappa + \sigma)t + \ln c_3 \quad \text{at } t = 0 \text{ and } \ln c_3 = \ln I_0$$

$$\ln \left(\frac{I(t)}{I_0} \right) \geq -(\mu + \kappa + \sigma)t$$

taking exponentials on both sides,

$$I(t) \geq I_0 e^{-(\mu + \kappa + \sigma)t}$$

therefore the third equation of the system (3.1) is also positive for all $t > 0$, since $e^t > 0$ for all $t \in \mathbb{R}$
From the fourth equation of the system (3.1)

$$\frac{dR}{dt} = \kappa I - \mu R \quad \text{implying} \quad \frac{dR}{dt} \geq -\mu R$$

separating the variables and integrating

$$\int \frac{dR}{R} \geq - \int \mu dt$$

giving

$$\ln R(t) \geq -\mu t + \ln c_4 \quad t = 0 \quad \text{and} \quad \ln c_4 = \ln R_0$$

$$\ln \left(\frac{R(t)}{R_0} \right) \geq -\mu t$$

taking exponentials on both sides

$$R(t) \geq R_0 e^{-\mu t} \quad R(t) \geq 0 \quad \forall t > 0$$

This implies that all the state variables are non negative for all $t > 0$

3.2 Boundedness of Solutions

By showing that the solutions are bounded implies that the model is epidemiologically well posed in Ω where $\Omega = (S, D, I, R)$ By adding the 4 equations in the system (3.1) to obtain the total population size as

$$N(t) = S(t) + D(t) + I(t) + R(t) \tag{3.2}$$

This gives

$$\begin{aligned} \frac{dN}{dt} &= \frac{dS}{dt} + \frac{dD}{dt} + \frac{dI}{dt} + \frac{dR}{dt} \\ &= \pi - \mu S - \mu D - \mu I - \mu R - \sigma I \\ &= \pi - (S + D + I + R)\mu - \sigma I \end{aligned}$$

and from (3.2)

$$\frac{dN}{dt} = \pi - \mu N - \sigma I \tag{3.3}$$

Proof. Let $\Omega = (S, D, I, R) \in \mathbb{R}_+^4$ be any solution of the model equation with non-zero condition. In the absence of infection or disease, equation (3.3) becomes

$$\frac{dN}{dt} \leq \pi - \mu N$$

that can be rearranged to give

$$\frac{dN}{dt} + \mu N \leq \pi \tag{3.4}$$

This is a linear first order differential equation that can be solved by multiplying both sides of equation (3.4) by the integrating factor $e^{\mu t}$, gives

$$e^{\mu} \frac{dN}{dt} + \mu N e^{\mu t} \leq \pi e^{\mu t}$$

$$d[Ne^{\mu t}] \leq \pi e^{\mu t} dt$$

integrating both sides, we have

$$\begin{aligned} Ne^{\mu t} &\leq \frac{\pi}{\mu} e^{\mu t} + c \\ N(t) &\leq \frac{\pi}{\mu} + ce^{-\mu t} \end{aligned}$$

Applying the initial conditions at

$$t = 0, \quad N(0) = N_0 \leq \frac{\pi}{\mu} + c \quad \Rightarrow \quad N_0 - \frac{\pi}{\mu} \leq c$$

and we now have

$$N(t) \leq \frac{\pi}{\mu} + \left[N_0 - \frac{\pi}{\mu} \right] e^{-\mu t} \tag{3.5}$$

as $t \rightarrow \infty$ in equation (3.5), the human population N approaches $K = \frac{\pi}{\mu}$ i.e $N \rightarrow K$. The parameter $K = \frac{\pi}{\mu}$ is the carrying capacity. Hence N is bounded and all feasible solution sets of the population of the model system approach or stay in the region

$$\Omega = \{S, D, I, R \in \mathbb{R}_+^4 : S \geq 0, D \geq 0, I \geq 0, R \geq 0, N \leq \frac{\pi}{\mu}\}$$

The region Ω is therefore positively invariant, that is the solution is positive for all time t and the model system is epidemiologically meaningful and Mathematical well posed in the domain Ω . Hence it is sufficient to consider the dynamics of the flow it generates in a proper subset

$$\Omega = \{(S, D, I, R) \in \mathbb{R}_+^4\}$$

□

4 Equilibria Points of The Model

Analysing the model to investigate the stability of its equilibria both at disease-free equilibrium (DFE) and disease -endemic equilibria (DEE). The disease-free equilibrium points of the model are its steady states solutions in the absence of infection, [Omondi et al (2015)]. Equilibria points of the model system in equation (3.1) is obtained by equating the derivatives to zero and solve for the variables

$$\begin{aligned} \pi - \beta SI - \mu S - \xi S &= 0 \\ \xi S - \mu D - (1 - \delta)\beta DI &= 0 \\ \beta SI + (1 - \delta)\beta DI - (\mu + \kappa + \sigma)I &= 0 \\ \kappa I - \mu R &= 0 \end{aligned} \tag{4.1}$$

Using $S + E = \frac{\pi}{\mu}$ it can be shown that at disease free equilibrium of the model system equation (3.1)

$$\begin{aligned} \pi - \mu S - \xi S = 0 &\Rightarrow S = \frac{\pi}{\mu + \xi} \\ \xi S - \mu D = 0 &\Rightarrow D = \frac{\xi S}{\mu} \\ D &= \frac{\xi \pi}{\mu(\mu + \xi)} \end{aligned}$$

$$\begin{aligned} DFE &= (S^0 D^0 I^0 R^0) \\ &= \left(\frac{\pi}{\mu + \xi}, \frac{\xi \pi}{\mu(\mu + \xi)}, 0, 0 \right) \end{aligned}$$

5 Basic Reproduction Number

Definition 5.1 (Basic Reproduction Number, Driessche and Watmough (2002)). The basic reproduction number R_0 in a given population is the average number of secondary infection caused by a single infectious individual during his/her entire lifetime as an infection when introduced into a totally or purely susceptible population

The dynamics of the model are highly dependent on the basic reproduction number R_0 in that π is directly related to the effort required to eliminate the infection. In this paper, the basic reproduction number R_D is the expected number of secondary SARS-nCoV 2 infection caused by a single infected individual in the presence of social distance awareness intervention, when no such kind of programmes are employed. We determine R_D using the next generation matrix approach [Driessche and Watmough (2002)]

Consider a matrix

$$G = FV^{-1}$$

where F is the Jacobian of f_j , where f_j is the rate of new infections in compartment j and V is the Jacobian of V_j , where V_j is the rate of transfer of infections from one compartment to another. From the system model equation (3.1)

$$F = \begin{pmatrix} \beta SI + (1 - \delta)\beta DI \\ 0 \end{pmatrix}$$

$$V = \begin{pmatrix} (\sigma + \mu + \kappa)I \\ 0 \end{pmatrix}$$

$$F = \begin{pmatrix} \beta S + (1 - \delta)\beta D & 0 \\ 0 & 0 \end{pmatrix}$$

at disease-free equilibrium DFE ,

$$S = \frac{\pi}{\xi + \mu} \quad \text{and} \quad D = \frac{\xi\pi}{\mu(\mu + \xi)}$$

$$F = \begin{pmatrix} \frac{\beta\pi}{\xi + \mu} + (1 - \delta)\frac{\beta\xi\pi}{\mu(\mu + \xi)} & 0 \\ 0 & 0 \end{pmatrix}$$

$$V = \begin{pmatrix} \sigma + \mu + \kappa \\ 0 \end{pmatrix}$$

we consequently determine

$$V^{-1} = \begin{pmatrix} \frac{1}{\sigma + \mu + \kappa} \\ 0 \end{pmatrix}$$

therefore

$$FV^{-1} = \begin{pmatrix} \frac{\beta\pi}{\xi + \mu} + (1 - \delta)\frac{\beta\xi\pi}{\mu(\mu + \xi)} & 0 \\ 0 & 0 \end{pmatrix} \begin{pmatrix} \frac{1}{\sigma + \mu + \kappa} \\ 0 \end{pmatrix}$$

$$FV^{-1} = \begin{pmatrix} \frac{1}{\sigma + \mu + \kappa} \left(\frac{\beta\pi}{\xi + \mu} + (1 - \delta) \frac{\beta\xi\pi}{\mu(\mu + \xi)} \right) & 0 \\ 0 & 0 \end{pmatrix}$$

computing the eigenvalues from the characteristic equation

$$\begin{bmatrix} \left(\frac{1}{(\mu + \kappa + \alpha)} \left[\frac{\beta\pi}{\mu + \xi} + (1 - \delta) \frac{\beta\xi\pi}{\mu(\xi + \mu)} \right] - \lambda \right) & 0 \\ 0 & -\lambda \end{bmatrix} = 0$$

and obtain

$$\lambda_1 = 0, \quad \lambda_2 = \frac{1}{(\mu + \kappa + \alpha)} \left[\frac{\beta\pi}{(\mu + \xi)} + (1 - \delta) \frac{\beta\xi\pi}{\mu(\mu + \xi)} \right]$$

for

$$\begin{aligned} \lambda_2 &= \frac{\beta\mu\pi + (1 - \delta)\beta\xi\pi}{\mu(\mu + \xi)(\mu + \kappa + \alpha)} \\ &= \frac{\beta\pi}{\mu(\mu + \kappa + \alpha)} \left(\frac{\mu + (1 - \delta)\xi}{(\xi + \mu)} \right) = R_D \end{aligned}$$

Therefore

$$R_D = \frac{\beta\pi}{\mu(\mu + \kappa + \alpha)} \left(\frac{\mu + (1 - \delta)\xi}{(\xi + \mu)} \right)$$

In the absence of social distancing intervention, $\xi = 0$ and the basic reproduction number becomes

$$\begin{aligned} R_0 &= \frac{\beta\pi}{\mu(\mu + \kappa + \alpha)} \left(\frac{\mu + (1 - \delta)0}{(0 + \mu)} \right) \\ &= \frac{\beta\pi}{\mu(\mu + \kappa + \alpha)} \end{aligned}$$

This implies

$$R_D = R_0 \left[\frac{\mu + (1 - \delta)\xi}{\mu + \xi} \right] \tag{5.1}$$

Since we have the set $0 < \xi < 1$, it follows that

$$\left(\frac{\mu + (1 - \delta)\xi}{\mu + \xi} \right) < 1$$

which implies $R_D < R_0$. It is clear that social distancing intervention on transmission of SARS-nCoV2 has a positive impact on the reduction of new infections. It is important to note that we have used the next generation matrix approach in estimating the basic reproduction number; however there exist other methods, including obtaining the eigenvalues of the Jacobian matrix, the survival function technique and existence of endemic equilibrium which can be employed in models where computations are not successful. [Li, Blakely and Smith (2020)]

6 Stability Analysis

6.1 Local Stability and Disease Free Equilibrium

Further analysis of the model to investigate the stability of its equilibrium. The disease-free equilibrium point of the model is its steady states solution in the absence of disease or infection.

Theorem 6.1. *The disease-free equilibrium of the model system (3.1) is locally asymptotically stable whenever $R_D < 1$ and unstable whenever $R_D > 1$*

Proof. We prove the theorem by obtaining the eigenvalues of the Jacobian matrix of the linearised system given by

$$J = \begin{pmatrix} -\beta I - \mu - \xi & 0 & -\beta S & 0 \\ 0 & -(\mu + (1 - \delta)\beta I) & -(1 - \delta)\beta D & 0 \\ \beta I & (1 - \delta)\beta I & \beta S + (1 - \delta)\beta D & 0 \\ 0 & 0 & \kappa & \mu \end{pmatrix}$$

We now compute the Jacobian matrix at DFE and investigate its stability effect due to the reproduction number R_D . The Jacobian matrix at DFE $S^0 D^0 I^0 R^0$ is given by

$$J(D^0) = \begin{pmatrix} -(\xi + \mu) & 0 & \frac{-\beta\pi}{\xi + \mu} & 0 \\ 0 & -\mu & -(1 - \delta)\frac{\beta\xi\pi}{\mu(\mu + \xi)} & 0 \\ 0 & 0 & \frac{\beta\pi}{\xi + \mu} + (1 - \delta)\frac{\beta\xi\pi}{\mu(\mu + \xi)} & 0 \\ 0 & 0 & \kappa & -\mu \end{pmatrix}$$

The characteristic equation is given by

$$|(J(D^0) - \lambda I)| = 0$$

$$|J(D^0) - \lambda I| = \begin{vmatrix} -(\xi + \mu + \lambda) & 0 & \frac{-\beta\pi}{\xi + \mu} & 0 \\ 0 & -\mu - \lambda & -(1 - \delta)\frac{\beta\xi\pi}{\mu(\mu + \xi)} & 0 \\ 0 & 0 & \left[\frac{\beta\pi}{\xi + \mu} + (1 - \delta)\frac{\beta\xi\pi}{\mu(\mu + \xi)} - (\sigma + \kappa + \mu) \right] - \lambda & 0 \\ 0 & 0 & \kappa & -(\mu + \lambda) \end{vmatrix}$$

We obtain the following eigenvalues

$$\begin{aligned} \lambda_1 &= -(\xi + \mu) \\ \lambda_2 &= -\mu \\ \lambda_3 &= \frac{\beta\pi}{\xi + \mu} + (1 - \delta)\frac{\beta\xi\pi}{\mu(\mu + \xi)} - (\sigma + \kappa + \mu) \\ \lambda_4 &= -\mu \end{aligned}$$

From λ_3 , we have

$$\lambda_3 = \frac{\beta\mu\pi + (1 - \delta)\beta\xi\pi - \mu(\mu + \xi)(\mu + \kappa + \sigma)}{\mu(\mu + \xi)}$$

But

$$R_D = \frac{\beta\mu\pi + (1 - \delta)\beta\xi\pi}{\mu(\mu + \xi)(\mu + \kappa + \sigma)}$$

This implies

$$\lambda_3 = (R_D - 1)(\mu + \kappa + \sigma)$$

If $R_E < 1$ then λ_3 is also negative. This clearly shows that $\lambda_1, \lambda_2, \lambda_3, \lambda_4$ are all negative. The eigenvalues have negative real parts from Routh-Hurwitz criterion [Bishop and Dorf (2017); Gantmacher (1959)]. Therefore the disease-free equilibrium is locally asymptotically stable in the region Ω if and only if $R_D < 1$, and unstable if $R_D > 1$. Hence the theorem is proved \square

6.2 Global Stability of the Disease-Free Equilibrium

The global stability of the disease-free equilibrium (DFE) is easily proved using a common Lyapunov function and La Salles' invariance principal

Theorem 6.2. *If $R_D \leq 0$ then the disease-free equilibrium of the model system (3.1) is globally asymptotically stable in the region Ω*

Proof. To prove the theorem, we begin by constructing a linear Lyapunov function We define

$$L : \{(S, D, I, R) \in \Omega, S, D > 0\} \rightarrow \mathbb{R}$$

by

$$L(S, D, I, R) = (\mu + \kappa + \alpha)I$$

The global stability of disease free equilibrium holds if its time derivative $\frac{dL}{dt} \leq 0$ The time derivative of Lyapunov function L is given by

$$\begin{aligned} \frac{dL}{dt} &= (\mu + \kappa + \sigma)I' \\ &= (\mu + \kappa + \sigma)(\beta SI + (1 - \delta)\beta DI) - (\mu + \kappa + \sigma) \\ &\leq (\mu + \kappa + \sigma) \left[\beta(S + D) - (\mu + \kappa + \sigma) \right] I \quad \text{but } S + D = \frac{\pi}{\mu} \\ &\leq (\mu + \kappa + \sigma) \left(\frac{\beta\pi}{\mu} - (\mu + \kappa + \sigma) \right) \\ &\leq (R_0 - 1)(\mu + \kappa + \sigma)(\mu + \kappa + \sigma)I \end{aligned}$$

Since $R_D < R_0$ in $o < \xi < 1$ We have

$$\frac{dL}{dt} \leq (R_D - 1)(\mu + \kappa + \sigma)^2 I$$

If $\frac{dL}{dt} = 0$, then $I = 0$. hence L is a Lyapunov function on Ω . Thus $I \rightarrow 0$ as $t \rightarrow \infty$ substituting $I = 0$ in equation (3.1) we obtain $S + D = \frac{\pi}{\mu}$. It therefore follows from La Salles invariance principle that every solution of the model system equation (3.1) with the initial condition in Ω , approaches DFE as $t \rightarrow \infty$ \square

6.3 Existence of A Unique Positive Endemic Equilibrium $E^*(S^* D^* I^* R^*)$

Lemma 6.3. *An endemic equilibrium $E^*(S^* D^* I^* R^*)$ exists provided that $R_D > 1$*

Proof. At endemic state, equation (3.1) becomes

$$\pi - \beta S_* I_* - \mu S_* - \xi S_* = 0 \tag{6.1}$$

$$\xi S_* - \mu D_* - (1 - \delta)\beta D_* I_* = 0 \tag{6.2}$$

$$\beta S_* I_* + (1 - \delta)\beta D_* I_* - (\sigma + \mu + \kappa)I_* = 0 \quad (6.3)$$

$$\kappa I_* - \mu R_* = 0 \quad (6.4)$$

To calculate the disease endemic equilibrium DEE, we set $(S, D, I, R) \neq 0$ and solving for S^* in (6.1)

$$S_* = \frac{\pi}{\beta I_* + \mu + \xi} \quad (6.5)$$

solving for E_* from equation (6.2)

$$D_* = \frac{\xi S_*}{\mu + (1 - \delta)\beta I_*} \quad (6.6)$$

From equation (6.3)

$$(\beta S_* + (1 - \delta)\beta D_* - (\sigma + \mu + \kappa)I_* = 0$$

but at Disease Endemic Equilibrium $I_* \neq 0$

$$\beta S_* + (1 - \delta)\beta D_* - (\sigma + \mu + \kappa) = 0$$

$$S_* = \frac{(\sigma + \mu + \kappa) - (1 - \delta)\beta D_*}{\beta} \quad (6.7)$$

and from equation (6.4)

$$R_* = \frac{\kappa I_*}{\mu} \quad (6.8)$$

To obtain the value of I_* we equate equations (6.5) and (6.7) with correct substitution for D_* , so that we have

$$\frac{\sigma + \mu + \kappa}{\beta} \left[\frac{\mu + (1 - \delta)\beta I_*}{\mu + (1 - \delta)\beta I_* + (1 - \delta)\xi} \right] = \frac{\pi}{\beta I_* + \xi + \mu} \quad (6.9)$$

solving for I_* from the above equation, we have

$$\begin{aligned} (1 - \delta)\beta^2(\sigma + \mu + \kappa)I_*^2 + [\beta\mu(\sigma + \mu + \kappa) + (1 - \delta)\beta(\mu\sigma + \mu^2 + \xi\kappa - \beta\pi)] \\ [\mu + (\sigma + \mu + \kappa) - \beta\pi(1 + (1 - \delta)\xi)] = 0 \end{aligned} \quad (6.10)$$

Equation (6.10) can be expressed quadratically as

$$AI_*^2 + BI_* + C = 0$$

where

$$A = (1 - \delta)\beta^2(\sigma\mu + \kappa)$$

$$B = \beta\mu(\sigma + \mu + \kappa) + (1 - \delta)\beta(\mu\sigma + \mu^2\xi\kappa - \beta\pi)$$

$$C = \mu(\mu + \sigma\kappa) - (\beta\pi + \beta\pi\xi(1 - \delta))$$

since

$$R_D = \frac{\beta\pi}{\mu + (\mu + \kappa + \sigma)} \left[\frac{\mu + (1 - \delta)\xi}{\mu + \xi} \right] > 1$$

It is easy to show that

$$\beta\pi + \beta\pi\xi(1 - \delta) > \mu(\mu + \sigma + \kappa)$$

This clearly proves that $C < 0$ when $R_D > 1$. Equation (6.10) can only be expressed as either

$$AI_*^2 + BI_* - C = 0$$

and by Descartes rule,[Eigenwilling (2010)]. There is only one positive root of equation (6.10), that is $I_* > 0$. We therefore conclude that there exist one unique positive disease endemic equilibrium whenever $R_D > 0$ \square

6.4 Local Stability of The Endemic Equilibrium

Theorem 6.4. *If $R_D > 1$, then the disease-endemic equilibrium of the model system (3.1) is locally asymptotically stable*

Proof. A disease is endemic in a population if it persist in the population. We investigate the stability of the $E_*(S_*D_*I_*R_*)$ using the Routh-Hurwitz criterion

The Jacobian matrix at $E_*(S_*D_*I_*R_*)$ given by

$$J_{D^*} = \begin{pmatrix} -\beta I_* - (\mu + \xi) & 0 & -\beta S_* & 0 \\ \xi & -(\mu + (1 - \delta)\beta I_*) & -(1 - \delta)\beta D_* & 0 \\ \beta I_* & (1 - \delta)\beta I_* & [(\mu + \kappa + \sigma - \beta S_* - (1 - \delta)\beta D_*)] & 0 \\ 0 & 0 & \kappa & -\mu \end{pmatrix}$$

The characteristic equation is given by

$$|J(E^*) - \lambda I| = 0$$

$$\begin{vmatrix} -(\beta I_* + \mu + \xi) - \lambda & 0 & -\beta S_* & 0 \\ \xi & -(\mu + (1 - \delta)\beta I_*) - \lambda & -(1 - \delta)\beta D_* & 0 \\ \beta I_* & (1 - \delta)\beta I_* & (\mu + \kappa + \sigma) - \beta S_* - (1 - \delta)\beta D_* - \lambda & 0 \\ 0 & 0 & \kappa & -\mu - \lambda \end{vmatrix} = 0$$

The characteristic equation associated with the Jacobian matrix above is given by

$$B_0\lambda^4 + B_1\lambda^3 + B_2\lambda^2 + B_3\lambda + B_4 = 0 \tag{6.11}$$

where

$$\begin{aligned} B_0 &= 1 \\ B_1 &= \mu + d_1 + d_3 + d_5 \\ B_2 &= d_1(d_2 + d_5 + \mu) + d_2(d_5 + \mu) + d_3d_4 \\ B_3 &= d_1d_2(\mu + d_5) + \mu d_5(d_1 + d_2) + d_3d_4(d_1 + \mu) \\ B_4 &= d_1\mu(d_2d_5 + d_3d_4) + d_4\xi\mu\beta S_* \end{aligned}$$

and

$$\begin{aligned}
 d_1 &= \beta I_* + \mu + \xi \\
 d_2 &= \mu + (1 - \delta)\beta I_* \\
 d_3 &= (1 - \delta)\beta D_* \\
 d_4 &= (1 - \delta)\beta I_* \\
 d_5 &= (\mu + \kappa + \alpha) - \beta S_* - (1 - \delta)\beta D_*
 \end{aligned}$$

From equation (6.11), the constants $B_0, B_1, B_2, B_3,$ and B_4 are all positive. Now using Routh-Hurwitz criterion for a fourth degree polynomial [Bishop and Dorf (2017)], to ascertain the stability of the characteristic equation which satisfy the necessary condition for Routh-Hurwitz criterion, we next verify the sufficient condition for the Routh- Hurwitz criterion of stability. Therefore constructing the Routh array;

$$\begin{array}{c|ccc}
 \lambda^4 & B_0 & B_2 & B_4 \\
 \lambda^3 & B_1 & B_3 & 0 \\
 \lambda^2 & a_1 & B_4 & 0 \\
 \lambda^1 & a_2 & 0 & 0 \\
 \lambda^0 & B_4 & 0 & 0
 \end{array}$$

where

$$\begin{aligned}
 a_1 &= \frac{B_1 B_2 - B_0 B_3}{B_1} > 0 \quad \text{for } B_1 B_2 > B_0 B_3 \\
 a_2 &= B_3 - \frac{B_1^2 B_4}{B_1 B_2 - B_0 B_3} > 0 \quad \text{for } B_3 > \frac{B_1^2 B_4}{B_1 B_2 - B_0 B_3}
 \end{aligned}$$

All the elements of the first column of the Routh array are positive. There is no sign change in the first column of the Routh array which is the sufficient condition for the Routh-Hurwitz stability. Hence the endemic equilibrium is locally asymptotically stable. \square

6.5 Global Stability of the Endemic Equilibrium of the Model (EE)

To prove the global stability of the endemic equilibrium, E^* under the condition $R_D > 1$ we apply the Lyapunov function [Bishop and Dorf (2017); Gantmacher (1959); Murray (1993)], that takes advantage of the property of the function.

$$h(x) = x - 1 - \ln(x)$$

which is positive in $(0, \infty)$ except at $x = 1$ where it vanishes

Theorem 6.5. *The endemic equilibrium E^* of the model (3.1) is globally asymptotically stable in Ω whenever $R_D > 1$*

Proof. Consider the following Logarithmic Lyapunov function V defined by

$$V(S, E, I, R) = \sum_{i=1}^4 (x_i - x_i^* \ln x_i)$$

x_i is the population of the i^{th} compartment while x_i^* is the equilibrium value of x_i . Lyapunov function denoted by V is continuous and differentiable. The global stability of the endemic equilibrium holds if its time derivative $\frac{dV}{dt} \leq 0$. The time derivative of Lyapunov function V is given by

$$\frac{dV}{dt}(S, E, I, R) = \sum_{i=1}^4 \left(1 - \frac{x_i^*}{x_i}\right) \frac{dx_i}{dt}$$

so that we have

$$\begin{aligned} \frac{dV}{dt} &= \left(1 - \frac{S^*}{S}\right) \frac{dS}{dt} + \left(1 - \frac{D^*}{D}\right) \frac{dD}{dt} + \left(1 - \frac{I^*}{I}\right) \frac{dI}{dt} + \left(1 - \frac{R^*}{R}\right) \frac{dR}{dt} \\ &= \left(1 - \frac{S^*}{S}\right) [\pi - \beta SI - \mu S - \xi S] + \left(1 - \frac{D^*}{D}\right) [\xi S - \mu D - (1 - \delta)\beta DI] \\ &\quad + \left(1 - \frac{I^*}{I}\right) [\beta SI + (1 - \delta)\beta DI - (\mu + \kappa + \sigma)I] + \left(1 - \frac{R^*}{R}\right) [\kappa I - \mu R] \end{aligned} \quad (6.12)$$

An endemic equilibrium $S' = D' = I' = R' = 0$, we therefore can have the following substitutions
From equation (6.1), we have

$$\pi = \beta S^* I^* + \mu S + \xi S^* \quad (6.13)$$

From equation (6.2), we have

$$(\mu + \kappa + \sigma) = \left(\frac{\beta S^* I^* + (1 - \delta)\beta D^* I^*}{I^*}\right) \quad (6.14)$$

From equation (6.3), we have

$$\beta = \left(\frac{\xi S^* + \mu D^*}{(1 - \delta)D^* I^*}\right) \quad (6.15)$$

from equation (6.4). Next we make

$$\kappa = \frac{\mu R^*}{I^*} \quad (6.16)$$

Using equations (6.13),(6.14),(6.15)and (6.16) to rewrite equation (6.12) and simplifications yields

$$\begin{aligned} \frac{dV}{dt} &= (\mu + \xi)S^* \left(2 - \frac{S^*}{S} - \frac{S}{S^*}\right) + \left(1 - \frac{S^*}{S}\right) \left(1 - \frac{SI}{S^* I^*}\right) \\ &\quad + \left(1 - \frac{D^*}{D}\right) + \left[\xi \left(1 - \frac{S^* DI}{SD^* I^*}\right) - \mu \left(1 + \frac{I}{I^*}\right)\right] \\ &\quad + \left(1 - \frac{I^*}{I}\right) \left(\frac{\xi S^* + \mu D^*}{D^*}\right) \frac{I}{I^*} \left[\frac{1}{1 - \delta} \left(1 - \frac{S^*}{S}\right) + \left(1 - \frac{D^*}{D}\right)\right] \\ &\quad + \left(1 - \frac{R^*}{R}\right) \left[1 - \frac{I^* R}{I R^*}\right] \end{aligned}$$

□

At

$$S = S^*, \quad D = D^*, \quad I = I^* \quad R = R^*$$

and from the property that the geometric mean and is less than or equal to arithmetic mean, the inequality $\frac{dV}{dt} \leq 0$ holds if and only if (S,D,I,R) takes the equilibrium values $S^* D^* I^* R^*$. Therefore, by LaSalle's invariance Principle,[LaSalle (1976)] the endemic equilibrium E^* is globally asymptotically stable. Global asymptotic stability shows that regardless of any solution,the solution of the model will converge at E^* whenever $R_D > 1$. Epidemiologically, any perturbation of the model solution by the introduction of infectives shows that the model solution will converge to the E^* whenever $R_D > 1$

7 Numerical Simulations

Numerical simulations were carried using MATLAB R2021b to graphically illustrate the long term effect of social distance intervention on the dynamics 2019-nCov/SARS-CoV2 infection. The solution of the model above is done using parameter values shown in table below

Table 1 . solution of the model

Parameter Description	Symbol	Value	Source
Susceptible Population Recruitment Rate	π	0.1545	Anita and Jerigan (2020)
Effective Contact Transmission Rate	β	2.985×10^{-8}	Computed
Natural Death Rate	μ	5.2×10^{-8}	?
Infection Death Rate	σ	2.607×10^{-7}	Anita and Jerigan (2020)
Success Rate of Social Distance Intervention	δ	0.75	Assumed
Recovered Reverting to Susceptible Population	κ	6.75×10^{-1}	Assumed

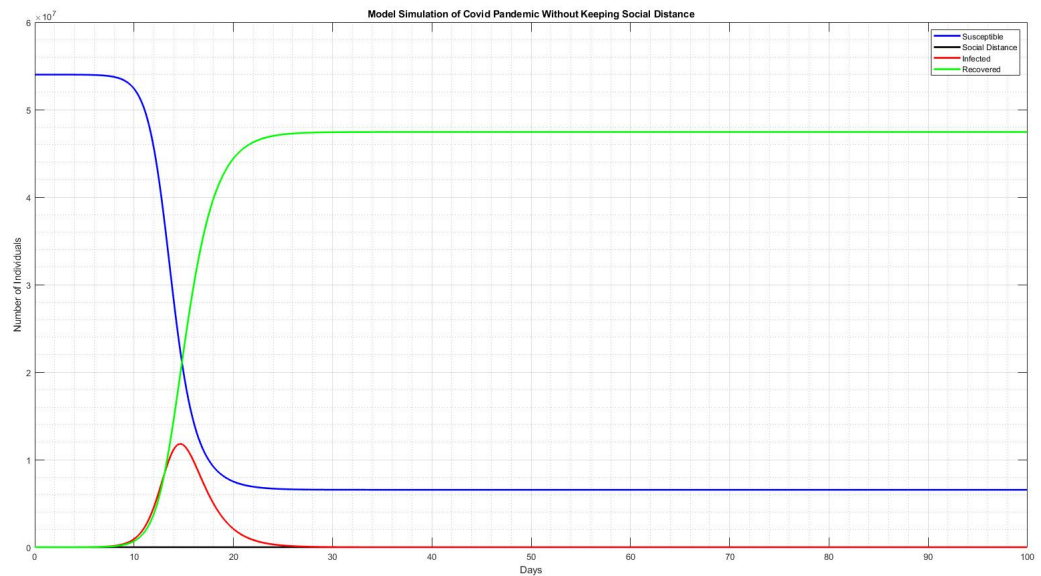

Figure 2: Spread of SARS-nCov2 Keeping Social Distance

8 Discussion

From 2 it is clear that the population of the susceptible individuals shortly starts dropping due to social distancing intervention, consequently the recovered individuals starts to rise. The number of 2019-nCoV/SARS-nCoV2 infected individuals increase for a short period then decreases before stabilising below the susceptible population. This is an indication that social distancing intervention is key to reduction in the infection rate of 2019-nCoV/SARS-nCoV2 hence public gatherings in political rallies, worship centers, market places, football matches should be put on hold. The ministry of health and in particular, department of public health together with other stakeholders should suggest measures where social distancing is kept. Similarly 3 with a slight decrease in social distancing intervention δ i.e the population of exposed population becomes apparently high and the recovered population also reduces.

9 Conclusion and Recommendations

In this study, a deterministic mathematical model based on systems of ordinary differential equations for the dynamics of 2019-nCoV/SARS-CoV2 transmission incorporating social distancing as a control measure was derived. The stability of the disease free and endemic equilibrium have been analysed. The results of the disease free equilibrium showed that the model is both locally and globally stable when $R_{SE} < 1$ thus reducing R_{SE} to less than unity reduces the spread of the disease. Endemic equilibrium has also been analysed and was found to be locally asymptotically stable when $R_{SE} < 1$. Numerical simulation shows that in the presence of social distancing intervention. Reduction of public gatherings is a major strategy for low 2019-nCoV/SARS-nCoV2 infection rate.

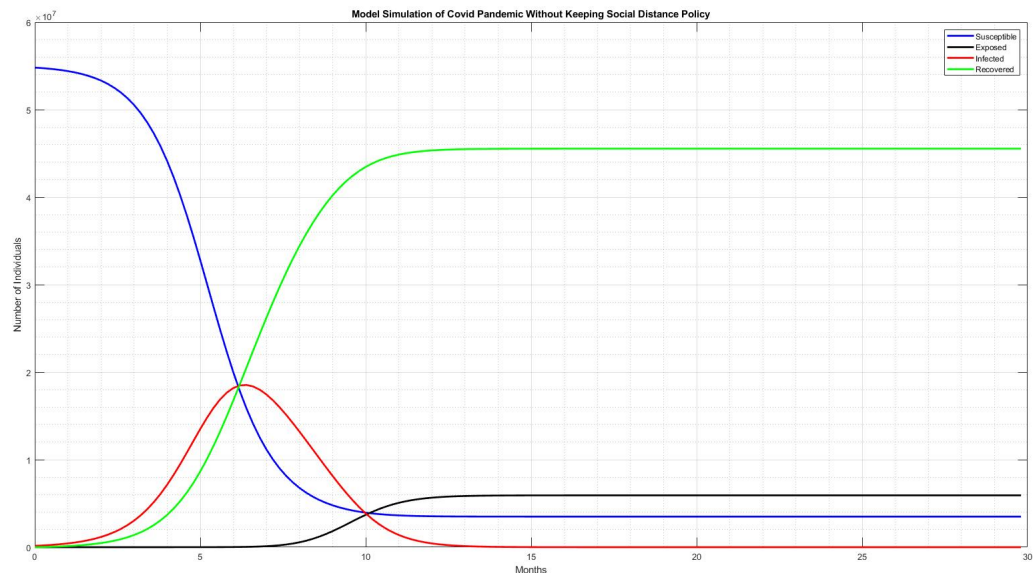

Figure 3: Spread of SARS-nCov2 Without Keeping Social Distance

References

- Anita, P., and Jerigan, D. (2020) Initial Public Health Response and Interim Clinical Guidance for the 2019 Novel Coronavirus Outbreak- United States Morbidity and Mortality Weekly Report MMWR Vol 65 No. 5 February 7, 2020.
- Chen, N. (2020) Epidemiological and Clinical Characteristics of 99 cases of 2019 Novel Coronavirus Pneumonia in Wuhan, China. A Descriptive Study *Lancet*:395: 507-513 doi.org/10.1016/50140-6736(20)30211-7
- Chowell, G., Blumberg, S., and Simonson, L. (2014) Synthesizing data and Models for Spread of MERS-CoV Transmissions in the Middle East Region, Combined Modeling Approach. *Epidemics* 2014;9:40-51
- Donglai, W., Changchung, T., Chanon, X., Hua, X., Qingwen, M., Yinggang, L., Yedong, Y., Yuntao, G., Yu, J., Xunnan, Y., Cramer, G., Muping, W., Changwen, L., Shengwang, R., Ming, L., Feng, L., Xiang, H., Junfu, S., Jinding, C., Yanwe, S., Shaolin, G., Nihong, L., Dexia, F., Eaton, B., Linta, W. and Xiang, H. (2004) Civets Are Equally Susceptible To Experimental Infection By Two Different Severe Acute Respiratory Syndrome Coronavirus Isolate. *Journal of Virology* Volume 79 pg 2620-2625 doi:10.1128/JVI.4.2620-2625.2005
- Donnelly, C., Ghann, C., Leung, M., Hedley, J., Fraser, S., Risly, S., Abu-Raddad, J., Ho, L., Thach, Q., Chau, P., Chan, P., Lam, H., Tse, Y., Tsang, T., Liu, H., Kong, H., Lau, M., Ferguson, M. and Anderson, M. (2003) Epidemiological Determinants of Spread of Causal Agent of Severe Acute Respiratory Syndrome in Hong Kong. *Lancet* 361:1761-1766
- Dorf, R. and Bishop, R. (2017) *Modern Control Systems* 13th Edition. Pearson Education, Inc. New Jersey, USA.
- Eiegenwilling, A. (2010) Real Root Isolation for Exact and Appropriate Polynomials Using Descartes' Rule of Signs
- Fehr, A. and Perlman, S. (2016) Coronaviruses: An Overview of their Replication and Pathogenesis. *Journal of Methods of Molecular Biology* 2015:1282:1-23 doi:10.1007/978-1-4939-2438-7-1
- Gantmacher, F. R. (1959) *Application of The Theory of Matrices*. Interscience Publishers, Inc. London, England.
- Huo, F. and Wang, Y. (2016) Impact of Media Coverage on Drinking Dynamics in A Scale Free-Network. *Springerplus* 5(1), 204 (2016).
- Kucharski, A., Russell, T., Diamond, C. and Yang, L. (2020) Early Dynamics of Transmission and Control of Covid 19. A Mathematical Modeling Study. *Lancet Infectious Disease* 2020. [https://dx.doi.org/10.1016/51473-3099\(20\)30144-4](https://dx.doi.org/10.1016/51473-3099(20)30144-4)
- Kiesha, P., Yang, L., Russell, T., Kucharski, A., Eggo, R. and Davies, N. (2020) Effects of Control Strategies to Reduce Social Mixing Outcomes of COVID 19 Epidemic in Wuhan, China: A Model Study. *Center for Mathematical Modeling of Infectious Disease Epidemiology*. London School of Hygiene and Tropical Medicine. doi.org/10.1016/52468-2667(20)30073-6
- Lee, N., Hui, D., Chan, P., Cameron, G., Joynt, A., Ahuja, M., Yung, C., Leung, K., Lui, C. and Ching, S. (2003) A Major Outbreak of Severe Acute Respiratory Syndrome in Hong Kong. *New England Journal of Medicine* 348:1986-1994

-
- Li,Q.,Guan,X.,Wu,P.(2020)Early Transmission Dynamics in Wuhan, China of Novel Coronavirus-Infected Pneumonia New England Journal of Medicine 2020 doi.org/10.1056/NEJM.a2001316
- Li,J.,Blakely,D. and Smith,R.(2011)The Failure of R_0 Comput. Math. Methods Med
- Lu,R.,Zhao,X.,Li,J(2020)Genomic Characterisation and Epidemiology of 2019 Coronavirus: Implication of Virus Origin and Receptor Binding. Lancet 2020 doi.org/10.1016/s140-6736(20)30251-8
- LaSalle J.P (1976)The Stability of Dynamical System. SIAM, Philadelphia
- Murray,J.D.(2002)Mathematical Biology 3rd Edition, Springer Verlag,Berlin
- Omondi L.O.,Chuncheng, W., Xiaoping, X. and Owuor, L.(2015) Modeling Effects of vaccination on Rotavirus Infection Journal of Advances in Differential Equations. doi=(10.1186/513662-015-0722-1)
- Peiris,J.,Yuen,K.,Osterhaus,A. and Storch,K.(2003)The Severe Acute Respiratory Syndrome. The New England Journal of Medicine 2003;349(25):2431-2441 [PubMed 14681510]
- Qianying, L., Chiu,A.,Zhao,S. and Dailai,H.(2018)Modeling The Spread of Middle East Respiratory Syndrome Coronavirus in Saudi Arabia. Journal of Statistical Method in Medical Research 2018 Volume 27(7)1968-1978 doi:10.1177/0962280217746442
- Reed,C.,Biggerstaff,L.,Finneli,L.(2013)Novel Framework for Assessing Epidemiological Effects of Influenza Epidemics and Pandemics. Journal of Emerging Infectious Diseases 2013;19:85-91 doi.org/10.3201/eid1901.120124
- Tiamu,C.,Jia,R.,Quipeng,W.,Zeyu,Z.,Jing,A. and Ling,Y.(2020)A Mathematical Model for Simulating Transmission of Wuhan Novel Coronavirus. <https://dx.doi.org/10.1101/2020.01.19.911669>
- Van de Driessche, and Watmough, J.(2002). Reproduction numbers and sub-endemic equilibria for compartmental models of disease transmission. Math. Biosci. 180(1-2) pg 29-48 Yao,H. and Liang, R. (2015)Vaccination Strategies of Modified SIS Model on Complex Networks. IJCTT 4(3),346-351
- Zhou,Y.,Yuan,H.,Jiayo,S.,Yin,H.,William,M. and Fexiong, C.(2020)Nat. Cell Discovery 2020 6:4 pg doi.org/10.1038/s41421-020-0153-3
- Zumla,A.,Chan,J.,Azar,E.,Hui,D. and Yuen,K.(2016)Coronavirus Drug Discovery and Therapeutic Options. Nat. Rev. Drug Discovery 15:327-347