

### **Factors Affecting Covid-19 Vaccine Hesitancy in University Students**

#### **Abstract**

##### **Background**

During the Covid-19 pandemic, many people have not been vaccinated. One of the most important reasons for this is the people who are hesitant about the vaccine. If the factors affecting vaccination are revealed and awareness-raising activities are carried out, deaths due to the Covid-19 pandemic can be reduced by ensuring that more people are vaccinated.

##### **Aim**

Our aim is to reveal the factors affecting the Covid-19 vaccine hesitancy in university students.

##### **Material and method**

Our study was carried out on 1005 students who participated in the study at the University of the Turkish Republic of Northern Cyprus.

The sociodemographic characteristics of the students were determined, questions were asked about the factors affecting the vaccination by face-to-face survey method, and the results were evaluated statistically.

##### **Results**

451 people out of 1005 students had hesitations about getting the Covid-19 vaccines, and 554 students were vaccinated without hesitation. The most important reasons for the hesitations of the students; fear of needles, belief that the vaccine is ineffective, fear of the side effects of the vaccine, and the thought that they do not need to be vaccinated because other people are vaccinated have been found to be effective.

##### **Conclusion**

In order to increase vaccination rates among university students, vaccines should be made with needle-free methods, and studies to raise awareness about the effectiveness and side effects of Covid-19 vaccines should be urgently planned and implemented by authorized institutions.

**Keywords:**Covid-19, vaccines, hesitations,affecting,factors.

#### **INTRODUCTION**

The Covid-19 (C-19) epidemic started in the Wuhan region of China in 2019, turned into a pandemic in a short time, and caused the death of over 6 million people. Currently, C-19 disease causes the death of thousands of people every day in the world[1].

Vaccines are our most important weapon in the fight against C-19[2]. According to US Disease Control and Prevention (CDC) data, the rate of getting C-19 disease and death rate in people who are fully vaccinated is 13.9-53.2 times reduced [3]. Despite this, millions of people in many countries around the world are hesitant to get vaccines despite the possibility of getting C-19 vaccine(V), and accordingly, the rates of illness and death are increasing [4,5,6]. In order for Vs to be effective at the community level in pandemics, at least 67% of the population should be V adequately[7]. It is very difficult to eradicate pandemics unless these percentages are reached in vaccination rates. In the C-19 pandemic, those who did not

have a V are one of the most important factors affecting inadequate vaccination. As of March 2021, 25% of African-Americans, 37% of Latinos, and 28% of white Americans in the US have not had V[8].

It may be an effective solution to research the factors that affect getting V and to carry out awareness-raising studies for the cause.

Therefore, in our study, the factors affecting getting a V in university students in the TRNC were investigated, the results were statistically evaluated, discussed and comments were made.

## **MATERIAL AND METHODS**

Our study was carried out on 1005 students who are students at the ...University of the Turkish Republic of Northern Cyprus (TRNC).

In order to carry out our study, approval was obtained from the ...Health Sciences Ethics Committee.

(... Health Sciences ethics committee approval number:2021-22/001)

All students participating in our study read the standard informed consent form and their consent was obtained. Students with physical disabilities and C-19 disease in the last 3 months were not included in our study.

The questions we prepared to investigate the factors affecting the V of the students participating in our study were asked face-to-face.

According to the answers given, they were divided into 2 groups as students who hesitated (Group A) and those who did not (Group B).

First of all, the questions shown in Table 1 were asked to determine the sociodemographic characteristics of the students. Afterwards, the participants were asked whether they had had one of the Vs and if they had any hesitations about getting the vaccine.

Those who were not V or who had hesitations about Vs despite having no disability were included in Group A, and those who did not hesitate and had vaccinated against C-19 were included in Group B. The participants in Group A were asked about the reasons for hesitation against V (4-choice answer), the reasons for getting V in Group B (4-choice answer).

In addition, all participants were asked whether they used drugs from this group, including tranquilizers, antibiotics and vitamin group drugs, during the pandemic process.

The survey results were evaluated statistically.

### **Statistical evaluation methods:**

Whether the data were suitable for normal distribution was examined using the Shapiro Wilk test. For those with continuous variability, the median (minimum-maximum) for those that do not follow the normal distribution is indicated. Descriptive statistics according to categorical variables are expressed as frequency and percentage. In the independent group comparisons of continuous variables for the hypotheses, Kruskal Wallis test was used when there were more than two independent groups and Mann Whitney U test was used when there were two independent groups. Explanatory factor analysis (EFA) and confirmatory factor analysis (CFA) were used to develop the scale used in the study. "Cronbach Alpha" was calculated to calculate the reliability analysis of the scale applied in the study, Cronbach Alpha shows the internal consistency coefficient. In testing the hypotheses of the study, the number of  $\alpha$  values was taken as 0.05. For this reason, 95% confidence level was found in the analysis results of the study. The analyzes in the study were obtained using IBM SPSS v.21 and IBM AMOS v.24 package programs.

## **RESULTS**

The sociodemographic findings of the participants are shown in (Table 1).

**Table 1. Sociodemographic characteristics of the participants.**

Sociodemographic Characteristics (n=1005)		Group A n=451		Group B n=554		Total		P
		Number (n)	Percent (%)	Number (n)	Percent (%)	Number (n)	Percent (%)	
<b>Sex</b>	Female	161	35,7	243	43,9	404	40,2	<b>0,009</b>
	Male	290	64,3	311	56,1	601	59,8	
<b>Social media</b>	Yes	439	97,3	539	97,3	978	97,3	0,964
	No	12	2,7	15	2,7	27	2,7	
<b>Reliable Information Source</b>	Social media	147	32,6	163	29,4	310	30,8	<b>p&lt;0,001</b>
	Classical Media	5	1,1	22	4,0	27	2,7	
	Friends	4	0,9	69	12,5	73	7,3	
	Public Health Institutions	95	21,1	179	32,3	274	27,3	
	Scientific Publications	142	31,4	166	29,9	308	30,6	

40.2% of the participants are female and 59.8% are male. While 97.3% of the participants use social media, 2.7% do not.

The number of female students in Group A was found to be significantly higher than those in Group B ( $p < 0.05$ ) (Table 1).

The post-modification DFA results of the knowledge and practices scale for vaccine hesitancy are shown in (Table 2) and (Figure 1).

**Table 2. The post-modification DFA results of the knowledge and practices for vaccine hesitancy**

$\chi^2$	sd	$\chi^2 / \text{sd}$	RMSEA	CFI	GFI	RMR
583,076	30	19,436	0,136	0,935	0,904	0,071

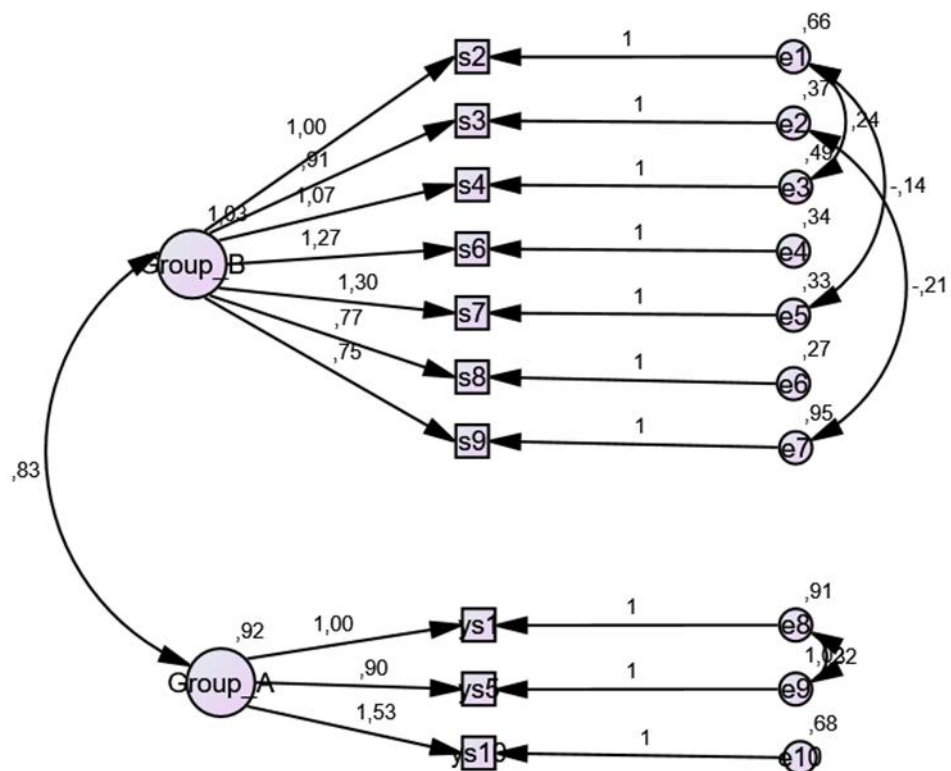

**Figure 1. The post-modification DFA results of the knowledge and practices scale for vaccine hesitancy.**

The factors affecting the vaccination of students in Group A and Group B are shown in (Table 3).

**Table 3. The factors affecting the vaccination of students in Group A and Group B**

	<b>Factors</b>	<b>Number (n)</b>	<b>Percent (%)</b>
<b>Group A</b>	Fear of the side effects of the vaccine	95	21,1
	Fear of needles	168	37,3
	Not believing the vaccine is effective	121	26,8
	Believing that they do not need to be vaccinated when others are vaccinated	67	14,9
<b>Group B</b>	They believe in that vaccination protect from illness	180	32,5
	Believing that a vaccine will protect them from death	34	6,1
	Believing that the vaccine will reduce the risk of contamination	85	15,3
	Because it is compulsory for institutions or abroad to enter and exit	255	46,0

In Group A, the most important factor leading to vaccination hesitancy was fear of needles (37.3%), while the most important factor affecting vaccination in Group B was ease of entry and exit to institutions (46.0).

Chi-square analysis and comparison results of the most reliable information sources in Group A and Group B are shown in (Table 4).

**Table 4. The results of the chi-square analysis of the groups according to the reliable information source**

	Group A		Group B		p
	(n)	(%)	(n)	(%)	
Social media	147	32,6	163	29,4	<b>p&lt;0,001</b>
Classical Media	5	1,1	22	4,0	
Friends	4	0,9	69	12,5	
Public Health Institutions	95	21,1	179	32,3	
Scientific Publications	142	31,4	166	29,9	

In our study, it was determined that SM was more trusted as a reliable source of information in Group A with vaccine hesitancy than Group B.

Chi-square analysis results in Group A and Group B according to the drug groups used are shown in (Table 5).

**Table 5. Chi-square analysis results in Group A and Group B according to the drug groups used.**

Drug groups	Group A		Group B		p
	(n)	(%)	(n)	(%)	
Tranquillizer	174	38,6	145	26,1	<b>p&lt;0,001</b>
Antibiotic	72	16,0	75	13,5	p>0.05
Vitamin	135	29,9	184	33,2	<b>p&lt;0,001</b>

Students using tranquilizer drug group were found to be statistically higher in Group A, and students using vitamin group drugs were found to be statistically higher in Group B.

## DISCUSSION

In a study by Kotta et al., they developed and validated a multidimensional V hesitancy scale by interviewing 1503 Hungarian citizens to reveal the factors affecting V[9]. In this scale, which was prepared on the basis of skepticism, fear and risk; statistically significant differences were found according to the health status, gender and social differences of the individuals.

In a study conducted by Zhenga on 800 participants, it was determined that the increase in the perception of V side effects decreases the desire to get V, the increase in the level of

knowledge about Vs increases the desire to get V, and when the doctor-patient relationship becomes stronger, the desire to get V increases[10].

In many studies, statistically significant differences were observed in sociodemographic findings between people who are reluctant to be V and those who do not[11,12,13].

In an online study conducted by Tam et al. on 1062 college students about hesitancy to be V, the results were evaluated by multinomial regression analysis, and it was revealed that 11.6% of the cases did not want to be V, 62.3% were hesitant against the V, and 26.1% were willing to be V.

It has been observed that those who are hesitant or unwilling to be V are statistically significantly female students, and the most important reason for this is the possible side effects of Vs[11].

According to the findings we obtained in our study, it was observed that the students who were hesitant about V were mostly female students and there was a statistically significant difference between them compared to male students (Table 1).

In a study conducted by Reno et al. in Northern Italy, it was determined that 31.1% of those who were hesitant to be V were mostly female, with low education and low income level[12].

In a systematic analysis conducted by Wake et al., 45 studies on the desire to be V were reviewed, and it was determined that the country with the highest V request was China (91.3%), and the country with the least V request was Congo (27.7%). According to the data obtained in the study, it was determined that the female gender had a statistically significant higher rate of hesitancy to be V than the men, and that the rate of hesitancy to be V significantly increased in the low education level and low income level.

In another study, it was shown that people with low income during the pandemic process, as well as being V, comply less with hygiene rules and receive less vitamin support against C-19 disease[14].

As in many issues, social media (SM) had a significant impact on the hesitancy to be V in the C-19 Pandemic[15]. Since the first days of the pandemic, many false news about V has spread rapidly on SM and accordingly, many people have been hesitant about V. Anti-V supporters gained a significant support through SM[16,17]. Exposure to false and anti-V information about V on social media has negatively affected people's willingness to have a V [18].

The rise of anti-V groups has become one of the biggest obstacles to immunization programs for governments and health activists in many countries [19].

In our study, it was determined that SM was more trusted as a reliable source of information in Group A with vaccine hesitancy than Group B (Table 4).

The fact that our study was conducted on a group with a high level of education may have been influential in the scientific publications being the most reliable source of information for the participants. In a study by Maciuszek et al, it was revealed that belief in science increased the tendency to get V [20].

In a study by Corcoran et al, it was revealed that Christian nationalism negatively affected the desire to be V[21]. However, we did not analyse this character of the students in our study.

According to the results we obtained in our study, the most important reason for those with V hesitancy was the fear of needles (Table 3). Other important reasons; disbelief in the effect of V, the thought that he will not need to be V if other people are V, and the fear that V has side effects.

In a systematic analysis conducted by McLennon et al, 119 studies on needle fear were analysed, and it was found that 20-50% of adolescents and 20-30% of young adults have needle-phobia [22]. In the study, it was revealed that fear of needles is more common in females at a rate of 1.4. In order to overcome the fear of needles, it has been suggested that

vaccines should be made with needle-free methods and cognitive therapy methods should be applied.

In a study by Chan et al. in Malaysia, it was revealed that the best way to influence people who hesitate to have a V is to communicate[23].

In some studies, the fear of Vs side effects has emerged as the most important reason for vaccine hesitancy[11,24]. The high level of education of the participants in our study may be the reason why the side effects of V were effective in V hesitancy in the second degree.

There may be a relationship between the V hesitancy of university students and the type of drugs they take. In a study conducted with multivariable logistic regression analysis on 1,166,917 V people in England, it was shown that people who get anxiolytic and antipsychotic drugs were more likely to be hesitant about vaccination than those who did not, and it did not change in those who took antidepressant drugs [25]. In our study, those who used the tranquilizing drug group were found to be statistically significantly higher in Group A, revealing the fact that especially this group of students required a different approach in vaccination programs(Table 5).

No significant difference was found between the rates of participants using antibiotic group drugs in both groups (Table 5). However, the participants using the vitamin group drugs were found to be significantly higher in Group B than in Group A (Table 5). In another study, it was shown that people with higher education levels used vitamin C and D group drugs more during the pandemic [14].

One of the factors that cause hesitation about getting Vs may be the type of V.

In an online study conducted by Salerno et al. with 2667 college students in Italy, the factors affecting hesitancy against mRNA and viral vector Vs were investigated. It was revealed that students showed more resistance and hesitation against viral vector Vs[26]. Since various V options were offered to our students at the University where our study was conducted, this factor was not taken into consideration.

The limited aspect of our study is that the study was conducted only on university students. According to the results we obtained in our study, the causes of V hesitancy vary according to the cultural structure of societies, education level and some sociodemographic characteristics. For this reason, in order to increase V rates, it is the most logical solution to raise awareness on these issues by revealing the reasons leading to V hesitancy.

## **CONCLUSION**

In order to increase the Covid-19 vaccination rates in university students;

- 1.Covid-19 vaccines should be administered with needle-free methods, and cognitive therapy that can reduce fear of needles should be applied.
- 2.Awareness-raising studies based on scientific evidence on the effectiveness and side effects of Covid-19 vaccines should be planned and implemented immediately by authorized institutions.
3. Social media should be used more effectively in awareness-raising activities to be carried out by authorized public institutions.

## **ETHICAL APPROVAL**

The Health Sciences Ethical Committee of Girne American University gave approval to this study.  
Approval number: 2021-22/001.

## **CONSENT**

As per international standard or university standard, Participants' written consent has been collected and preserved by the author(s).

## COMPETING INTERESTS DISCLAIMER:

Authors have declared that no competing interests exist. The products used for this research are commonly and predominantly use products in our area of research and country. There is absolutely no conflict of interest between the authors and producers of the products because we do not intend to use these products as an avenue for any litigation but for the advancement of knowledge. Also, the research was not funded by the producing company rather it was funded by personal efforts of the authors.

## REFERENCES

1. COVID Live - Coronavirus Statistics – Worldometer: May 04,2022.
2. Ciotti M, Ciccozzi M, Pieri M, Bernardini S: The COVID-19 pandemic: viral variants and vaccine efficacy. *Critical Reviews in Clinical Laboratory Sciences*.2022;59(1).
3. Amelia GJ, Avnika BA, Akilah RA,Brooke H, Betsy LC,Shivani A et al: COVID-19 Incidence and Death Rates Among Unvaccinated and Fully Vaccinated Adults with and Without Booster Doses During Periods of Delta and Omicron Variant Emergence — 25 U.S. Jurisdictions, April 4–December 25, 2021. *Centers for Disease Control and Prevention(CDC) Reports*. 2022; 71(4);132–138.
4. İkişik H, Sezerol MA, Taşçı Y,Maral I: COVID-19 vaccine hesitancy: A community-based research in Turkey. *International Journal of Clinical Practice*.2021; <https://doi.org/10.1111/ijcp>.
5. Davis T, Yimam AK, Kalam A, Tolossa AD, Kanwagi R, Bauler S,et al: Behavioural Determinants of COVID-19-Vaccine Acceptance in Rural Areas of Six Lower- and Middle-Income Countries. *Vaccines*. 2022;10(2).
6. Galanisa P,Vrakab I,Siskouc O, Konstantakopoulouc O, Katsiroumpaa A, Kaitelidou D: Willingness, refusal and influential factors of parents to vaccinate their children against the COVID-19: A systematic review and meta-analysis. *Preventive Medicine*.2022.<https://doi.org/10.1016/j.ypmed>.
7. Kwok KO, Lai F, Wei WI, Wong SYS, Tang JWT: immunity–estimating the level required to halt the COVID-19 epidemics in affected countries. *Journal of Infection*.2020; 80(6).
8. Saad BO,Regina MB, Noel TB, Alison MB, Timoty C, Arthur C et al: Promoting COVID-19 vaccine acceptance: recommendations from the Lancet Commission on Vaccine Refusal, Acceptance, and Demand in the USA.*The Lancet*.2021;398(10317):2186-2192.
9. Kotta I, Kalcza-Janosi K, Szabo K,Marschalko EE: Development and Validation of the Multidimensional COVID-19 Vaccine Hesitancy Scale. *Human Vaccines & Immunotherapeutics*.2022;18(1).

10. Zhenga H, Jiangb S, Wub Q: Factors influencing COVID-19 vaccination intention: The roles of vaccine knowledge, vaccine risk perception, and doctor-patient communication. *Patient Education and Counseling*.2022;105(2):277-283.
11. Tam CC, Qiao S, Li X: Factors associated with decision making on COVID-19 vaccine acceptance among college students in South Carolina. *Psychology, Health & Medicine*.2022;27(1).
12. Reno C, Maietti E, Fantinin MP, Savoria E, Manzoli L, Montalti M et al: Enhancing COVID-19 Vaccines Acceptance: Results from a Survey on Vaccine Hesitancy in Northern Italy. *Vaccines*.2021; 9(4).
13. Wake AD: The Willingness to Receive COVID-19 Vaccine and Its Associated Factors: "Vaccination Refusal Could Prolong the War of This Pandemic" – A Systematic Review. *Risk Manag Healthc Policy*. 2021; 14: 2609–2623.
14. Çaydaş Ş, Acar H: The Effects of Sociodemographic Factors on the u askıya alınmıştır.se of Supplementary Vitamins and the Follow Hygiene Rules in the COVID-19 Pandemic in TRNC.*Journal of Pharmaceutical Research International*.2022;34(23B):32-38.
15. Acar H:Covid-19 Pandemisinde Digital Medyanın Etkileri. *Güncel İletişim Çalışmaları 1*. Editörler:Y. Doç.Dr.Muharrem Özdemir,Doç Dr Neriman Saygılı. ISBN:978-625-7403-71-9.Bengü yayınevi. 1. Baskı. Ankara.2022;p:8-12.
16. Sun Y, Chia S, Lu F, Oktavianus J: (2022). The Battle is On: Factors that Motivate People to Combat Anti-Vaccine Misinformation. *Health Communication*.2022;37(3):327-336.
17. Martin S, Vanderslott S: (2021). "Any idea how fast 'It's just a mask!' can turn into 'It's just a vaccine!'": From mask mandates to vaccine mandates during the COVID-19 pandemic. *Vaccine*.2021; <https://doi.org/10.1016/j.vaccine.2021.10.031>.
18. Roozenbeek J, Schneider C, Dryhurst S, Kerr J, Freema A, Recchia G et al: Susceptibility to misinformation about COVID-19 around the world. *Royal Society Open Science*, 2020; <https://doi.org/10.1098/rsos.201199>.
19. Puri N, Coomesb E, Haghbayanc H, Gunaratne K: Social media and vaccine hesitancy: new updates for the era of COVID-19 and globalized infectious diseases. *Human Vaccines & Immunotherapeutics*.2020;16(11):2587-2592.
20. Maciuszek J, Polak M, Stasiuk K, Doliński D:Active pro-vaccine and anti-vaccine groups: Their group identities and attitudes toward science. *PLoS One*.2021;30(16): 1-15.
21. Corcoran KE, Scheitle C, DiGregorio B: Christian Nationalism and COVID-19 Vaccine Hesitancy and Uptake.*Vaccine*.2021;39(45).

22. McLenon J, Rogers MAM: The fear of needles: A systematic review and meta-analysis. *Journal of Advanced Nursing*.2018; <https://doi.org/10.1111/jan.13818>.
23. Chan NN, Ong KW, Siau CS, Lee KW, Peh SC, Yacob S et al: The lived experiences of a COVID-19 immunization programme: vaccine hesitancy and vaccine refusal. . *BMC Public Health*.2022; 22(296).
24. Leng A, Maitland E, Siyuan W, Nicholas S, Liu R, Wang J: Individual preferences for COVID-19 vaccination in China. *Vaccine*.2021;39(2): 247–254.
25. Murphy S, O'Reilly D, Owen RK, Akbari A, Lowthian E, Bedston S, et al: Variations in COVID-19 vaccination uptake among people in receipt of psychotropic drugs: cross-sectional analysis of a national population-based prospective cohort. *The British Journal of Psychiatry*.2022; <https://doi.org/10.1192/bjp.2022.36>.
26. Salerno L, Craxi L: Factors Affecting Hesitancy to mRNA and Viral Vector COVID-19 Vaccines among College Students in Italy. *Vaccines*.2021;9(8).