

Development of Comfortable Umbrella with Fan by Using Solar Energy

ABSTRACT

Heat wave often comes in tropical regions during sunny days in summer season, and sometimes temperature increases even over 42 degrees Celsius. Because overheat wave can cause heatstroke for human beings who work outside, umbrellas are usually used to cut off sunshine to protect them. In the paper, an umbrella prototype is designed, which can drive a fan to provide cooling effect for persons who work outside in tropical regions. The designed umbrella uses solar cell attached on the above surface of the umbrella to convert solar energy into electricity, which is used to drive a fan or charge a battery. Moreover, the battery can also drive the fan when sunshine intensity is weak, or provide a charging port with 5 voltages for portable devices, such as mobile phones. The key component to realize these functions is an electronic control module, which includes charging circuit and discharging circuit. The former increases output voltage from the solar cell to the desired voltage to charge the battery; the latter can control electricity from the battery to drive the DC motor fan, led indicator, and charging port.

Keywords: charging circuit; discharging circuit; solar system; voltage step-down; voltage step-up.

1. INTRODUCTION

Heat wind is very common in tropical regions, such as Indonesia, in summer season. When heat wave comes, the temperature increases to 42 degrees Celsius sometimes. Such kind of sultry weather makes people rather uncomfortable when they do activities outside. People must take action to protect themselves from sunlight, such as using umbrellas. In order to prevent these people from getting heatstroke, a fan is considered to install under the umbrella to reinforce air circulation. Solar energy, as renewable energy, can be converted into electrical energy by using solar cells [1-3].

This paper purposes how to design a solar system, which drives a fan installed in an umbrella, and this design can provide wind flow and reduce temperature of person surroundings. The solar system includes several solar cells and a rechargeable battery to store electricity energy for usage when sunlight is weak. In this design, the fan will be placed next to the umbrella column, and blades of the fan does not affect umbrella folding [4]. On the other hand, the battery and electronic control module will be placed on the handle of the umbrella.

2. DESIGN OF SOLAR SYSTEM

2.1 Layout Design

The solar panel adhered to cloths of the umbrella is a main resource in this system, which produces power to turn on a fan installed at the umbrella frame. A switch button is required to control the fan on or off. The fan is driven by a 5V DC motor. This is enough to provide the airflow. Besides, the solar panel can provide electricity to charge lithium polymer (Li-Po) battery [5] when sunshine is available. In order to increase the performance of this system, the fan will be driven by power of the battery when the sun does not appear or is not strong. The battery is installed close to the handle of the umbrella. Charge/discharge controller is used among the solar panel, the battery, and the fan to regulate the output voltage and to protect the battery from overcharging. Overcharging the battery will cause it to explode, causing to harm the system. Figure 1 shows the total schematic of the system.

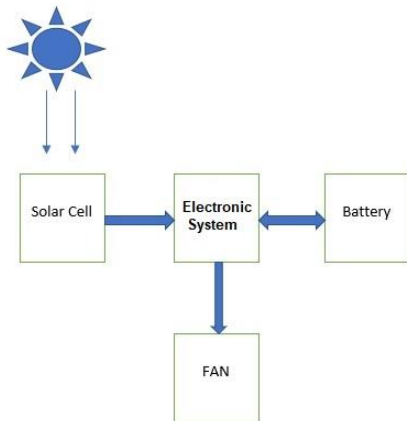

Fig. 1. Schematics of the system

2.2 Design of Electronic Circuit

One of the most challenging tasks of this system is to design and implement an electronic system module, whose functions are listed as below

- Battery voltage level indicator
- Charge electricity from the solar cell into the battery
- Discharge function to drive the fan
- Provide 5 voltages for the USB charging port

Consequently, the electronic control system requires two main circuits: power distribution circuit and battery charging control circuit. Electronic circuit designs include a battery voltage level indicator, charging and discharging system, whose electric circuits are shown in figure 2, 3, and 4, respectively.

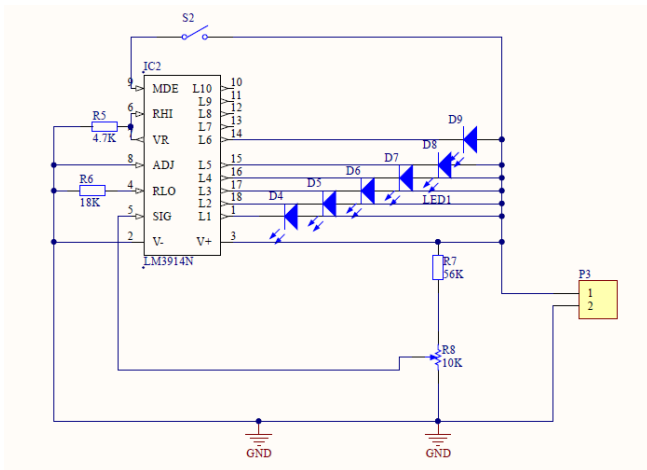

Fig. 2. Battery voltage level indicator circuit

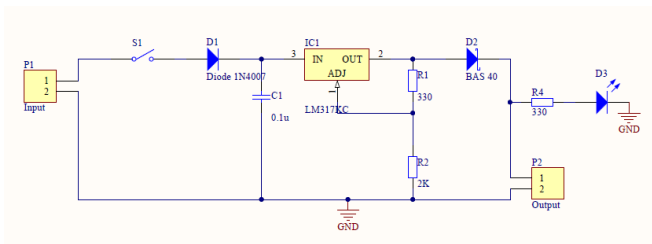

Fig. 3. Schematics of charging circuit

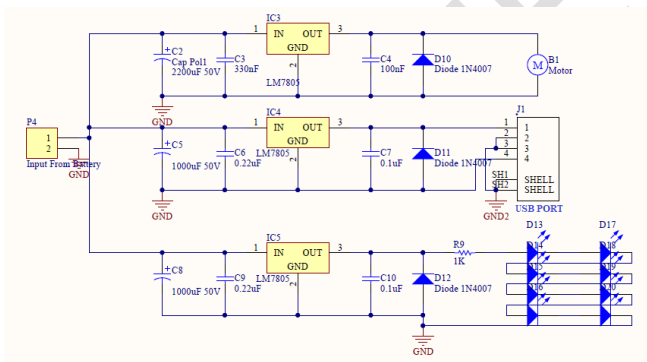

Fig. 4. Schematics of discharging circuit

The electronic circuit, using generally available low-cost components, is very simple, safe, and economical. The typical target voltage of a 2S Li-Po battery is usually 8.4 V (note that target voltage is not the same as the nominal voltage, which is 7.4 V typically), and Li-Po battery requires a special type of charging mode that uses the CC/CV method (constant current/constant voltage) with 1C charge grade (1 A for a 1,000mAh battery). However, charging at a lower than 1C rate is perfectly safe and will not damage any battery.

The design is optimized for batteries with capacity of 1,000mAh or higher, and the input power source can be any linear switch-mode power supply capable of catering an output current of minimum 1,500mA at 18V. Normally, a Li-Po battery connected to this circuit will be charged to 95% of its nominal voltage within 60 minutes and charged up to 100% of its target voltage within two hours thereafter.

A popular adjustable three-pin voltage regulator LM317T, in fact, is a perfect electronic component with blend of one constant current source and one constant voltage source, which is used in our design. In electric circuits shown in figure from 2 to 4, IC1 and R1 set the output limit current while IC2, R2 and P1 set the regulated voltage output. Related capacitors, C1 and C2, are used to increase circuit stability by reducing unwanted noise. The rest of the electronic circuit is one a bunch of visual indicators and their supporting components. LED1 (amber) is the “power-/battery-connected” indicator; LED2 (blue) is the “current flow” indicator, and LED3 (red) is the optional “battery-charged” indicator. The entire circuit can be constructed on a small PCB. All ICs must have heat sinks, and the TO-220 heatsinks should be isolated from other components of the circuit. After construction, feed 18V to the circuit through DC_IN jack (J1) and adjust P1 to get precisely 8.4 V (± 0.02 V) at the VBAT rail.

As far as construction of solar cell, solar panels are attached on cloths of the umbrella. The charging voltage requires more than 8.4V to provide power for the system, so 6 units of the solar panels with 1.6 volts are installed on the umbrella

3. PERFORMANCE ESTIMATION

3.1 Charge and Discharge Performance

As mention in the previous discussion, battery charger must provide a higher voltage than the voltage of battery so the charger voltage is around 8.4V for a Li-Po 7.4V/3200mAH battery. Output voltage of the regulator LM317T depends on the resistances of resistors R1 and R2 in figure 3, which can be calculated according to Eq. (1).

$$V_{out} = V_{ref} \left(1 + \frac{R2}{R1} \right) \dots\dots\dots (1)$$

In our design, $V_{ref} = 1.25V$, $R1 = 330\Omega$, and $R2 = 2K\Omega$, thus $V_{out} = 8.82V$, which satisfies charging condition.

The performances of the designed electronic control system can be investigated via simulation. Figure 5 illustrates the simulation schematic of charging circuit.

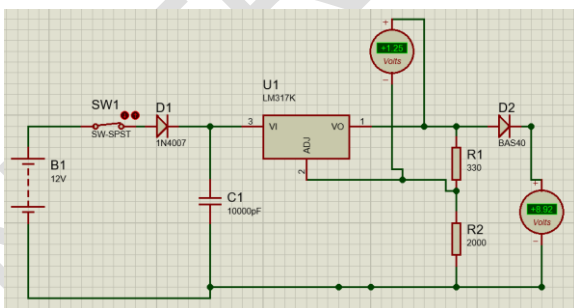

Fig. 5. Simulation schematic of charging circuit

Based on simulation circuit shown in figure 5, the simulation result shows the output voltage of charger is 8.92V, which is a little bit higher than the above calculated value, 8.82V. This output voltage is used to charge the Li-Po battery with 7.4V and capacity of 3200mAH. The charging time of battery can be calculated by the following equation.

$$T_c = \left(\frac{C_B}{I_c}\right) * 60\text{minute} \dots\dots\dots (2)$$

T_c = Charging time
 C_B = Battery capacity
 I_c = Charging current from charger

The calculation result shows that the completely charging battery needs 101.58 minutes or 1 hour 41.58 minutes. After fully charged, the battery can run until allowable cutoff voltage. Moreover, according to motor datasheet, the power of the fan motor equals 7.5Watt. Therefore, the running time of the fan motor can be calculated through below equation.

$$T_R = \frac{C_B}{P_M} \dots\dots\dots (3)$$

T_R = Running time of battery
 P_M = Power of motor

The calculation result shows 3 hour 13 minutes, which means the system fan can run at least 3 hours by using power from battery.

3.2 Performance of Airflow

The law of energy conservation states that energy cannot disappear and it is only converted from one form to another form. In our designed system, mechanic energy transformed from electric energy of the fan motor becomes kinetic energy of airflow [6, 7]. The shaft torque applies to blades, and then the rotation of the fan generates airflow. The following figure shows fan operation system.

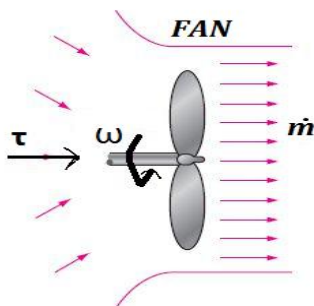

Fig. 6. Schematics of fan work system

The mechanical efficiency (η) of the fan is the ratio of the output mechanical energy to the input electrical energy, which can be written as follows.

$$\eta = \frac{W_{out}}{W_{in}} = \frac{P_{out}}{P_{in}} = \frac{0.5\dot{m} v^2}{P_{in}} \dots\dots\dots (4)$$

where P_{in} is power input. In this case, the efficiency selected between 0.6 - 0.7. The mass flow (\dot{m}) is defined as airflow through fan blades as follows

$$\dot{m} = \rho v A \dots\dots\dots (5)$$

where ρ is air density (kg/m^3), v is velocity of airflow (m/s), and A is cross-section area of circle of fan (m^2).

The relation among the torque of fan (T) in Nm, the angular velocity (ω) and the power supplies (P) in watt is expressed as follows.

$$P = \omega\tau = \pi n\tau/30 \quad (6)$$

The angular velocity can be written as n in RPM (revolution per minute).

3.3 Calculation Result of Airflow Performance

Figure 7 shows linear relation between the input power and RPM of the fan motor. Figure 8 indicates the relation between the airflow velocity and the power capacity supplied. More power is required for greater airflow velocity. Figure 9 illustrates the variation of the airflow velocity with the angular velocity of fan motor. Higher rotational speed could improve cooling effect for persons, but it would cause more vibration and noise, which makes them uncomfortable.

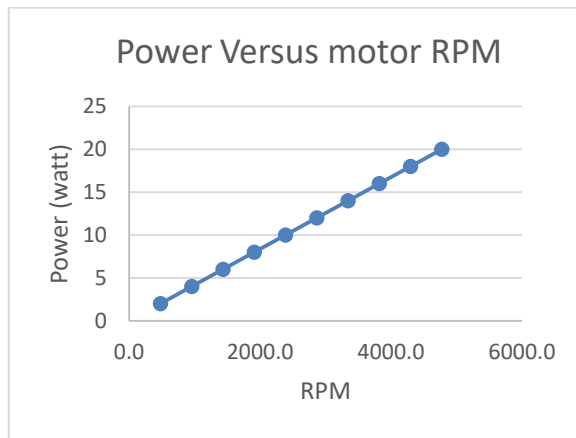

Fig. 7. Relation of power and motor RPM

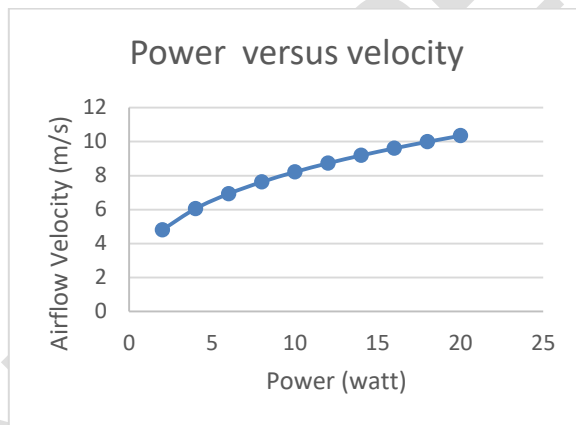

Fig. 8. Relation of power and airflow velocity

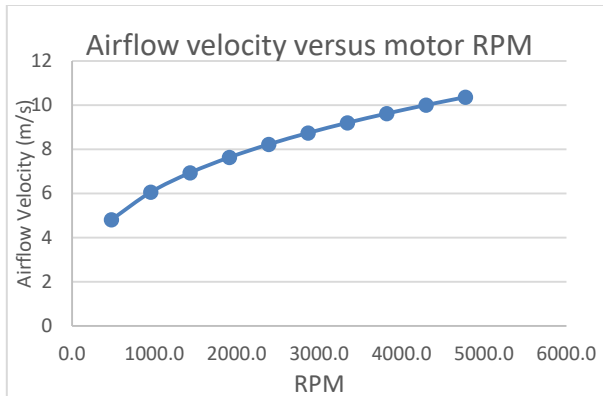

Fig. 9. Relation of airflow velocity and motor RPM

4. CONCLUSION

A comfortable umbrella has been designed. It contains an electronic control system, a fan motor, a battery and six solar cells. The umbrella can collect solar energy in sunny days and charge electricity into the battery which provides power to the fan motor in order to generate airflow for people outside in tropic regions. The next work is to optimize the prototype umbrella designed in the paper.

REFERENCES

1. McFarland EW. Solar energy: setting the economic bar from the top-down. *Energy and Environmental Science*. 2014; 7(3); 846–854.
2. Department of Energy Efficiency and renewable Energy, Improving Fan System Performance. 2003; Washington, D.C., US, 20585.
3. Renewable Energy Policy Network for the 21st Century. Renewable 2011 Global Status Report, 2011; 1:4.
4. Paul El Khoury, Yara Saadeh, Charbel Azzi, Samer Bu Jawdeh and Ramsey F. Hamade. Eco-Brella: prototype development of the umbrella as harvester of solar and wind energies. *Int. J. Sustainable Manufacturing*. 2014; 3(3).
5. What's the Best Battery?
Available: http://batteryuniversity.com/learn/article/whats_the_best_battery
6. Bruce R. Munson, Donald F. Young, Theodore H. Okiishi. *Fundamentals of fluid mechanics*. 2nd ed. John Wiley & Sons Inc; 1996.
7. Budynas, RG, Nisbett K. *Shigley's mechanical Engineering design*. 9th ed. MC Graw-Hill publishers, New York; 2011.