

## Case study

# An Application of Single and Multi-Server Exponential Queuing Model in Some Selected Hospitals of the North-Western Nigeria

### Abstract

*Time spent by the patients to get serviced at the hospital is becoming a major source of concern to health care providers. The results of keeping patients to wait for too long in a queue in order access medical services may put them in to so many inconveniences or at times can lead to death. Also, providing too much service capacity to operate a system incurs excessive cost. But not providing enough service capacity results in excessive waiting time and cost. This brings the need to strike a balance between excessive waiting time and cost. To achieve this, multi-server exponential queuing system was adopted and applied. The queuing performance characteristics were calculated with help of Microsoft Excel package. The data for this study were collected from eight hospitals across Katsina, Kaduna, Sokoto and Zamfara States in North-Western Nigeria through observations and personal interview. The results reveal that the General hospital Hunkuyi is the busiest because it has recorded the highest utilization factor as well as the highest number of patients in the queue. However, Ahmadau Bello University, Teaching hospital, Zaria is the least busy hospital and Federal medical centre, Katsina has the lowest number of patients in the queue.*

**Keywords:** *Waiting time, utilization factor, mutli-server queuing system, inter-arrival times, inter-service times.*

### Introduction

In Nigerian healthcare system, patients usually experience many sort of delays ranging from having to wait for hours or days before seeing a doctor to patients waiting for bed in

hallways. Delays occur when there is variation between a service's demand and the accessible resources to meet the demand. Patients may exit the queue whenever they realized that the waiting time and service time are high and this in effect results in frustration and patients' dissatisfaction. A well-managed queue management system in service delivery industries is beneficial to all stakeholders involved (Burodo et al., 2021). Queues emerge when individuals requesting service, usually called customers, arrive at a service facility and cannot be served on time. In healthcare delivery systems, patients are the customers and either outpatient clinics or hospitals are the service facilities. A common feature of the vast majority of queuing models is that customers are discrete, and the number of customers waiting in the service facilities is integer valued (Folake *et al.*, 2020). A queuing method that can optimize the number of servers, improve service efficiency should be able to minimize service cost and customers' waiting time (Burodo et al., 2019)

A queue is a waiting line (for instance patients waiting at the outpatients department and wanting to see a doctor); queuing theory is the mathematical theory of waiting lines. More generally, queuing theory is concerned with the mathematical modelling and analysis of systems that provide service to random demands. A queuing model is an abstract description of such a system. Typically, a queuing model represents

- (1). the system's physical configuration, by specifying the number and arrangement of the servers, which provide service to the customers, and
- (2). the stochastic (that is, probabilistic or statistical) nature of the demands, by specifying the variability in the arrival process and in the service process.

Waiting lines in health care sectors emerged when patients arrive randomly for services, such as walk-in patients and emergency room arrivals. Patients arriving for health care services with appointments are not considered as waiting lines, even if they wait to see their health

care provider. Most sorts of health care service systems have the capacity to serve more patients than they are called to over the long term.

The issue of queuing has been a subject of scientific debate for there is no known society that is not faced with the problem of queuing. Wherever there is competition for limited resource queuing is likely to occur (Koko, Burodo & Suleiman 2019).

Basic configuration of queuing model can be broken into input and output queuing system which include queue that must obey a queuing rule and service mechanics Hiller and Lieberman (2005). The simplest queuing model is called single-server single queue model as illustrated in figure 1. Single-server model has a single server and a single line of customers (Krasewski and Ritzman, 1998).

It is a situation in which customers from a single line are to be served by a single service facility or server, i.e. one after the other. For application of queuing model to any situation we should first describe the input process and the output process (Singh, 2006).

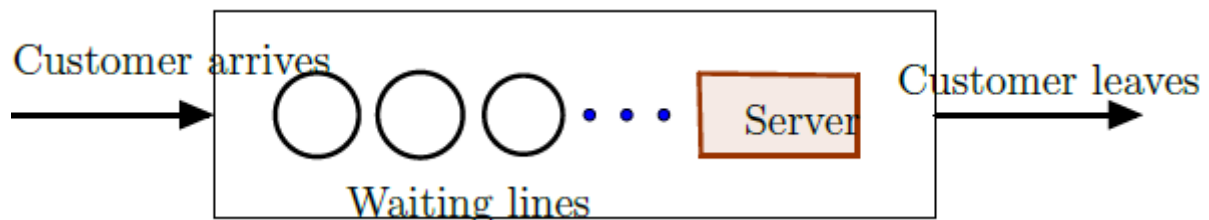

**Figure 1:** A view of Basic Queuing Process

Queuing theory has been used in many applications, financial institution (Burodo, Suleiman and Shaba, 2019, Boniface *et al.*, 2018), transportation (Koko, Burodo & Suleiman 2019, Nivya, Vincy and Arun, 2021), health care delivery (Prabakaran and Kumar, 2019, Ailobhio, Owolabi and Ayoo ,2020), day to day life (Shanmugasundaram and Umarani 2015), educational sector (Qureshi *et al.*,2014, Muhammad and Adamu, 2020), Restaurant (Gumus, Bubou, Oladeinde 2017, Igbinoba *et al.*, 2019), Super market (Igwe, Onwumere and Egbo 2014, Maragathasundari *et al.*,2019) among others.

Queuing System Characteristics

Queuing phenomenon include the following fundamental features Adedayo *et al.* (2006) and Medhi (2003): a) Arrival characteristics b) The queue or the physical line itself c) The number of servers or service channels d) Queue discipline e) Service mechanism f) The capacity of the system g) Departure

### Types of Queuing System

Queuing system are broadly categorized by Lapin (1981) in to four structures as follows:

#### Single-Server, Single-Phase System:

This describes a situation when single queue of customers are to be served by a single service facility (server) one after the other. Figure 2 depicts a single server-single- phase system.

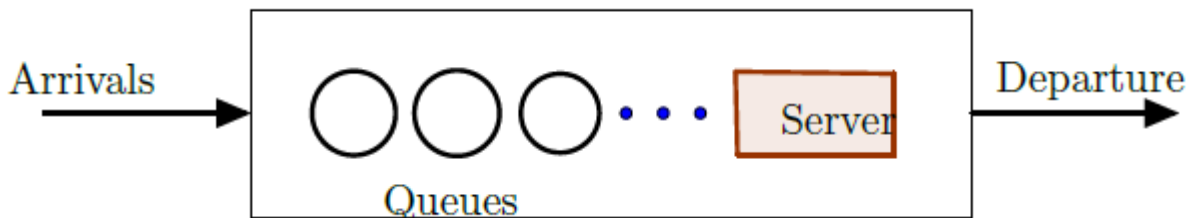

**Figure 2:** Single-Server, Single-Phase System

#### Single-server, Multiple-phases System:

This situation, still describes a single queue but customers/patients receive more than one kind of service before departing the queuing system as shown in figure 3. For instance, at outpatient department, patient first arrive at the records section, get the registration done and then wait in a queue to see a nurse for ancillary services before being seen by the doctor. Patients have to join queue at each phase of the system.

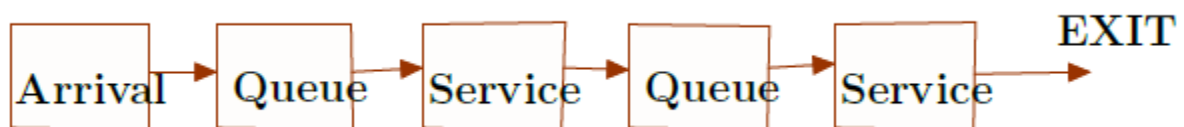
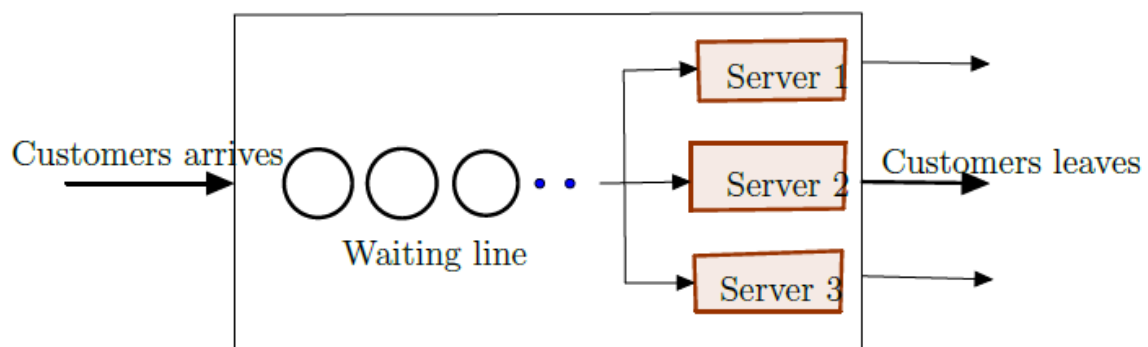

**Figure 3:** Single-Server, Multiple-Phases System

### Multiple-servers, Single-phase System:

This queuing system describes a situation where there is more than one service facility (servers) providing identical service but drawn on a single waiting line. This is particularly used when there are enough servers for example is patient waiting to see a doctor at general outpatient department of teaching hospitals and Federal medical centres. Figure 4 depicts

### Single-Server, Multiple-Phases System



**Figure 4:** multiple-servers, Single-phase System

### Multiple servers, Multiple-phases System:

This type of system describes situation with numerous queues and a complex network of multiple phases of services involved as can be seen in figure 5. This type of service is typically seen in a hospital setting, in a multi-specialty outpatient clinics patient first form the queue for registration, and then he/she is triage for assessment, then for diagnostics, review, treatment, intervention or prescription and finally exits from the system or triage to different provider.

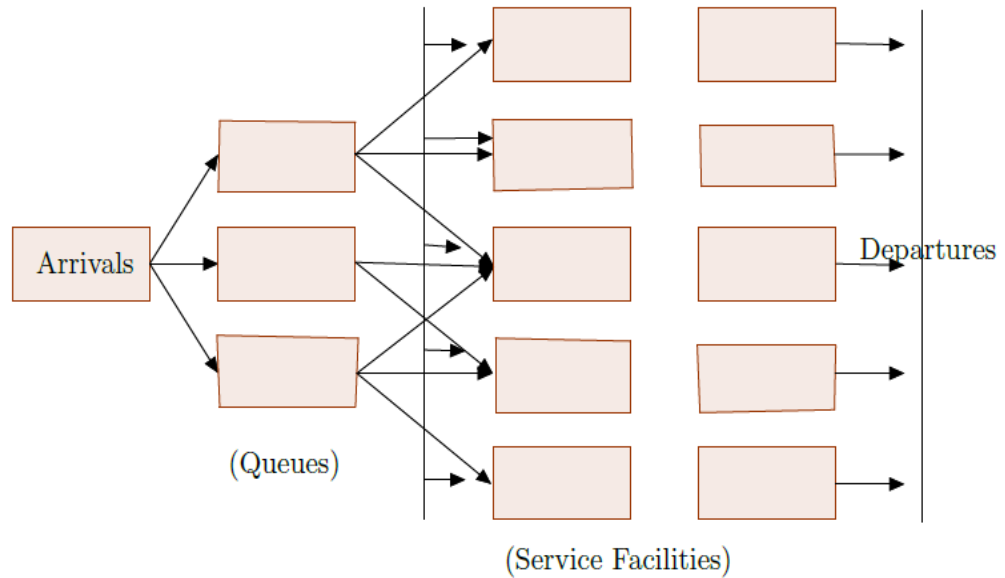

**Figure 5:** Multiple servers, Multiple-phases System

The main objective of the study was to analyse multi-server exponential queuing system across selected hospitals in the north-western Nigeria. Specifically, the following system performance characteristics were measured in this study: a) the average number of arrivals for the outpatients of Obstetrics and Gynaecology departments across the selected hospitals. b) The average service time of patients across the hospitals c) the probability that the facility will be idle d) the average time a patient spends waiting for a service

#### Queuing System Terminology and Notations

Queuing theory is a mathematical theory with its own standard terminologies and notations. Below are some of the basic terminology and notations of queuing theory adopted in this study:

$\lambda$ : Average (mean) arrival rate i.e. the rate of arrivals of patients at a system.

$\mu$ : Average (mean) service rate i.e. the rate at which patients could be served.

$\frac{1}{\lambda}$ : Expected inter-arrival time

$\frac{1}{\mu}$ : Expected inter-service time

$\rho$ : System utilization factor. i.e.  $= \frac{\lambda}{s\mu}$ , where  $s$  is the number of servers. It represents the fraction of the system's service capacity ( $s\mu$ ) that is being utilized in the average by arriving patients ( $\lambda$ ) (Hiller and Lieberman, 2001).

$L_q$ : Average number of customers waiting for service or waiting in the queue. i.e

$$L_q = \frac{\left(\frac{\lambda}{\mu}\right)^k}{k!(1-\rho^2)} P_0$$

$L_s$ : Average number of customers in the system (those waiting and receiving service)

$$L_s = L_q + \frac{\lambda}{\mu}$$

$W_q$ : Average time patients spent in the queue. i.e.  $W_q = \frac{L_q}{\lambda}$

$W_s$ : Average time patients spent in the system i.e.=

$$W_s = W_q + \frac{1}{\lambda}$$

$P_0$ : Probability of zero patients in the system i.e.

$$P_0 = \left[ \left\{ \sum_{n=0}^{k-1} \frac{1}{n!} \left(\frac{\lambda}{\mu}\right)^n \right\} + \frac{1}{k!} \left(\frac{\lambda}{\mu}\right)^k \left(\frac{k\mu}{k(\mu-\lambda)}\right) \right]^{-1}$$

$P_n$ : Probability of exactly  $n$  units or patients in the system i.e.

$$P(x = n) = 1 - \frac{\lambda}{\mu} \left(\frac{\lambda}{\mu}\right)^n = (1 - \rho)\rho^n$$

Probability of more than  $n$  units in the system  $= \rho^n$

## Results and Discussion

For the purpose of this study, primary data were collected through observational approach. The inter- arrivals and inter –services times in minutes of patients were observed for the hospitals considered in this research namely Federal Medical Centre, Katsina, General Hospital Katsina, Ahmadu Bello University Teaching Hospital, General Hospital Hunkuyi, Usmanu Danfodiyo University Teaching Hospital, General Hospital Wamakko, Federal Medical Centre Gusau and General Hospital Talata Mafara. The inter-arrivals and inter-

service time of patients for all the hospitals were used to compute the queuing parameters as discussed above. The results for these computations were summarized in tables below:

**Table 1:** Summary of Performance Parameters for FMC Katsina and General hospital, Katsina

Performance parameters	FMC Katsina		Average	General Hospital Malumfashi		Average
	Tuesday	Thursday		Wednesday 1	Wednesday 2	
Mean arrival rate ( $\lambda$ ) in minutes	3.4	2.8	3.1	2.6	2.2	2.4
Mean service rate ( $\mu$ ) in minutes	8.7	8.03	8.4	5.6	5.5	5.6
Mean combined rate of all servers ( $k\mu$ ) in minutes	26.1	24.1	25.1	5.6	5.5	5.6
Utilization factor of the entire system ( $\rho$ )	13%	12%	12.5%	46%	40%	43
Probability of zero patients in the system ( $P_0$ )	0.67	0.68	0.68	0.71	0.79	0.75
Average number of patients in the queue ( $L_q$ )	0.00678	0.004876	0.005828	0.41	0.38	0.40
Average number of patients in the system ( $L_s$ )	0.40	0.35	0.38	0.87	0.78	0.83
Average waiting time in the queue ( $W_q$ ) in minutes	0.12	0.13	0.13	0.33	0.35	0.34
Average time a patient spends in the system ( $W_s$ ) in minutes	0.41	0.49	0.45	0.71	0.80	0.76

**Table 2:** Summary of Performance Parameters for ABUTH, Zaria and General hospital, Hunkuyi

Performance parameters	ABUTH Zaria		Average	General Hospital, Hukunyi		Average
	Tuesday	Friday		Monday 1	Monday 2	
Mean arrival rate ( $\lambda$ ) in minutes	2.4	2.8	2.6	4.3	3.5	3.9
Mean service rate ( $\mu$ ) in minutes	9.0	7.2	8.1	5.3	3.6	4.5
Mean combined rate of all servers ( $k\mu$ ) in minutes	36	21.6	28.8	5.3	3.6	4.5

Utilization factor of the entire system ( $\rho$ )	7%	13%	10%	81%	97%	89%
Probability of zero patients in the system ( $P_0$ )	0.76	0.67	0.72	0.16	0.028	0.094
Average number of patients in the queue ( $L_q$ )	0.00016	0.0067	0.0034	0.38	0.46	0.42
Average number of patients in the system ( $L_s$ )	0.27	0.12	0.2	1.19	1.43	1.31
Average waiting time in the queue ( $W_q$ ) in minutes	0.11	0.043	0.077	0.28	0.41	0.35
Average time a patient spends in the system ( $W_s$ ) in minutes	0.53	0.4	0.47	0.51	0.7	0.61

**Table 3:** Summary of Performance Parameters for UDUTH Sokoto and General hospital, Wamakko

Performance parameters	UDUTH Sokoto		Average	General Hospital, Wamakko		Average
	Monday	Wednesday		Monday 1	Monday 2	
Mean arrival rate ( $\lambda$ ) in minutes	3.01	2.3	2.7	2.9	2.7	2.8
Mean service rate ( $\mu$ ) in minutes	9.1	7.3	8.2	5.8	5.5	5.7
Mean combined rate of all servers ( $k\mu$ ) in minutes	27.3	22	24.7	5.8	5.5	5.7
Utilization factor of the entire system ( $\rho$ )	11%	11%	11%	50%	49%	49.5%
Probability of zero patients in the system ( $P_0$ )	0.67	0.72	0.7	0.67	0.68	0.68
Average number of patients in the queue ( $L_q$ )	0.0041	0.0038	0.004	0.45	0.44	0.45
Average number of patients in the system ( $L_s$ )	0.33	0.32	0.3	0.95	0.94	0.95
Average waiting time in the queue ( $W_q$ ) in minutes	0.11	0.14	0.13	0.33	0.35	0.34
Average time a patient spends in the system ( $W_s$ ) in minutes	0.44	0.57	0.51	0.67	0.72	0.7

**Table 4:** Summary of Performance Parameters for FMC Gusau and General hospital, Talata Mafara

Performance parameters	FMC, Gusau		Average	General Hospital, Talata Mafara		Average
	Monday	Wednesday		Wednesday 1	Wednesday2	
Mean arrival rate ( $\lambda$ ) in minutes	3.2	2.5	2.9	3.2	3.8	3.5
Mean service rate ( $\mu$ ) in minutes	6.9	7.7	7.3	6.7	6.6	6.7
Mean combined rate of all servers ( $k\mu$ ) in minutes	13.8	23.1	18.5	6.7	6.6	6.7
Utilization factor of the entire system ( $\rho$ )	23%	11%	17%	48%	58%	53%
Probability of zero patients in the system ( $P_0$ )	0.64	0.75	0.7	0.7	0.56	0.63
Average number of patients in the queue ( $L_q$ )	0.16	0.0043	0.082	0.44	0.49	0.47
Average number of patients in the system ( $L_s$ )	0.62	0.33	0.48	0.92	1.1	1.01
Average waiting time in the queue ( $W_q$ ) in minutes	0.19	0.13	0.16	0.29	0.29	.29
Average time a patient spends in the system ( $W_s$ ) in minutes	0.5	0.53	0.52	0.6	0.55	0.58

It can be seen in from tables 1 to 4 that on average the general hospital Hunkuyi was the busiest of all the hospitals. Its utilization factor is 89%. The next busiest hospital is the general hospital Talata Mafara having a utilization rate of 53%. The third busiest hospital is the general hospital Wamakko with utilization factor of 49.5%. The least busy hospital is the Ahmadu Bello University Teaching hospital with a utilization rate of 10%. The Tables also show that the General hospitals Hunkuyi and Talata mafara have more patients waiting in the queue. On the average, a patient spends about 0.35 minutes in the queue and 0.61 minutes in

the system at the General hospital Hunkuyi. Similarly, on the average, a patient spends about 0.29 minutes in the queue and 0.59 minutes in the system at the General hospital Talata Mafara. However, on the average, the least number of patients in the queue was recorded at Federal medical Katsina (FMC, Katsina). On the average, a patient spends about 0.13 minutes in the queue and 0.45 minutes in the system at the Federal Medical Centre.

## **Conclusion**

Queue analyses were done with the use of observational data obtained from the eight hospitals considered in this study. The results of the Multi-server-single channel queuing Models reveal that the General hospital Hunkuyi is the busiest because it has recorded the highest utilization factor as well as the highest number of patients in the queue. However, Ahmadu Bello University, Teaching hospital, Zaria is the least busy hospital and Federal medical centre, Katsina has the lowest number of patients in the queue. It is also recommended that more doctors should be deployed to the hospitals especially where only one doctor operate at a time, so as to convert the single-channel queuing units to multi-channel queuing units.

## **Reference**

- Adedayo, A. O., Ojo, O., and Obamiro, J. K. (2006). *Operations Research in Decision Analysis and Production Management*. Pumark Nigeria Limited,Lagos.
- Ailobhio D. T. Owolabi T. Land Ayoo P.V (2020), Application of Queuing Theory in Antenatal Clinics, *IOSR Journal of Mathematics (IOSR-JM)*,16(6), 42-47
- Boniface O.I.,Donatus N.O., Mong E.E., Chinyeaka Z., Amaechi I.C.(2018) Application of Multi-Channel, Single Stage Queue Model to Optimize Service Delivery in Banking Industry (A Case Study of Diamond Bank PLC, Eziukwu Branch, Aba), *International Journal of Scientific Engineering and Science*, 2(2), 36-41
- Burodo M.S., Suleiman S. and Yusug G. (2021), An assessment of Queue management and Patient Satisfaction of Some Selected Hospitals in North-Western Nigeria, *International Journal of Mathematics and Statistics Invention (IJMSI)*, 9(8),14-24
- Burodo M.S., Suleiman S. and Shaba Y. (2019), Queuing Theory and ATM Service Optimization: Empirical Evidence from First Bank Plc, Kaura Namoda Branch,

Zamfara State *American Journal of Operations Management and Information Systems*; 4(3): 80-86. doi: 10.11648/j.ajomis.20190403.12

- Folake A.O., Agu M.N., and Okebanama U.F. (2020), "Application of Queue Model in Health Care Sector," *International Research Journal of Advanced Engineering and Science*, 5(3): 48-50.
- Gumus S., Bubou G.M., Oladeinde M.H (2017), Application of Queuing Theory to a Fast Food Outfit: A Study of Blue Meadows Restaurant, *Independent Journal of Management & Production (IJM&P)*, 8(2),441-458
- Hiller, S. F. and Lieberman, J. G. (2005). *Introduction to Operations research*. Boston: McGraw Hill, (8th. ed) edition edition.
- Igbinoba, J. O, Sule O.K, Ugboya .A.P and Akinwunmi, M. (2019), Application of Queuing Theory in Optimization of Service Process, A Case Study f GT Plaza Fast Food, *Journal of Multidisciplinary Engineering Science and Technology (JMEST)*,6(1), 9320- 9327
- Igwe A., Onwumere J.U.J. and Egbo O.P. (2014), Efficient Queue Management in Supermarkets: A Case Study of Makurdi Town, Nigeria, *European Journal of Business and Management*, 6(39),185-192
- Krasewski, G. and Ritzman, H. (1998). Improving personnel scheduling at health care centres. *Journal of Operations Research*, 43(74):17-21.
- Koko M.A., Burodo M.S. and Suleiman S. (2019). Queuing Theory and Its Application Analysis on Bus Services Using Single Server and Multiple Servers Model. *American Journal of Operations Management and Information Systems*. 3(4),81-85. doi: 10.11648/j.ajomis.20180304.12
- Lapin, L. (1981). *Quantitative Methods for Business Decision*. Harcourt: B. Jouanaurch, 2nd edition. edition.
- Maragathasundari S., Somasundaram R.S., Karunakaran P., Manikandan P.,(2019) Queuing System Modeling for Supermarkets, *International Journal of Innovative Technology and Exploring Engineering (IJITEE)*, 9(2),591-597
- Medhi, J. (2003). *Stochastic Models in Queuing Theory*. Amsterdam Academic Press, (2nd ed.) edition.
- Muhammad I. and Adamu L. (2020) Determination of Optimal Number of Servers at Network Queuing Nodes to Reduce Waiting Time in a Tertiary Institution Clinic in Bida, Nigeria, *Journal of Applied Environmental Management*, 24(9), 1631-1639.
- Nivya V.V., Vincy V. and Arun C. (2021). Application of Queuing Theory in Transportation, *International Journal of Engineering Research & Technology (IJERT)*, 9(6), 55-58

Prabakaran R. and Kumar K. (2019). Application of queuing theory in Hospital Management, *International Journal of Innovative Technology and Exploring Engineering (IJITEE)*, 8(8),1788-1790

Qureshi M.I.,Bhatti Khan M.A.and Zaman K.(2014), Measuring queuing system and time standards: A case study of student affairs in universities, *African journal of business management*, 8(2), 80-88

Shanmugasundaram S. and Umarani P (2015), Queuing theory applied in our day to day life, *International Journal of Scientific & Engineering Research*, 6(4), 534-541

UNDER PEER REVIEW