Development of an ESP-32 Microcontroller Based Weather Reporting Device

..... Article

ABSTRACT

This study presents a novel approach to incorporating technology into an intelligent weather station. In the recent years, the nation has experienced a decline in agricultural activity due to the change in climate causing lot of danger in the farm output; this enables the weather forecaster to actually prescribe disaster by employing the use of temperature, humidity and light sensors which senses the temperature and humidity in the atmosphere. A tipping bucket is used to measure the amount of rainfall with an ESP 32 microcontroller which displayed its results through a Liquid Crystal Display (LCD) and then send it to the registered number and at the same time is been sent to cloud for easy retrieval purpose using the internet which can be retrieved from any location. This system is designed primarily for use in the school meteorological stations, it is also applicable in various weather stations. The primary goal is to create a low-cost intelligent system for storing data obtained by measuring various physical parameters in the atmosphere, such as temperature, humidity, and rainfall. An ESP-32 is used as the technology for storing measured data; it is an advanced and efficient solution for connection to the Internet. The intelligent weather station system is built around the following steps: direct environmental sensing, data measurement and storage, and allowing users to access the results through the cloud. The system is built around a collection of embedded sensors, and a microcontroller serving as the system's core and server, and wireless internet communication protocol. The results were sent to the cloud, where they are displayed in a tabular and graphical format; these results can be exported from the cloud into an excel format.

Keywords: LCD, ESP-32; meteorological stations; embedded sensors; microcontroller; Internet of Things (IoT).

1. INTRODUCTION

In order to determine changes in weather elements and climate conditions, a weather station is required, which houses the sensors that measures the various weather elements. According to their functions, the following are some of the most common types of weather stations: Climatological and Rainfall Weather Stations. Weather station design involves finding an acceptable location and installing instruments in a manner consistent with that location's climate. Everything in the atmosphere interacts with each other to produce different weather conditions or weather events, and weather is nothing more than the sum of all of these interactions. First, we need to identify the weather's constituent elements [1-4]. Temperature, air pressure, wind (speed and direction), relative humidity, precipitation, visibility, cloud type and cover, sunshine length,

and the location of a weather station all play a role in how well an all-weather vehicle performs [5-9].

Human-to-human and device-to-device communication are both made possible by the Internet of Things (IoT). As high-speed Internet becomes more widely available, people around the world are becoming more linked. An additional step is taken by the Internet of Things (IoT), which connects electrical gadgets that can communicate with one another [10-12]. Wi-Fi-enabled devices are becoming increasingly affordable, and this trend will only continue. As a part of the Internet of Things (IoT), various electronic devices (sensors) can be connected via a network and then data can be retrieved from these devices and sent to a cloud service for analysis and processing [13,14]. A buzzer, an email, or a text message can all be used to alert others in the cloud service to this data.

2. COMPONENTS DESCRIPTION

2.1 ESP32 (Wi-Fi Module)

The ESP32 System-on-Chip microcontroller supports Wi-Fi 802.11 b/g/n, dual-mode Bluetooth 4.2, and a variety of peripherals. The 8266A, is essentially a two-core processor that can be clocked up to 240 MHz. Additionally, it has a 4MB flash memory, an increase in the number of GPIO pins from 17 to 36, and 16 additional PWM channels. The processor comprises a total of two central cores (the Extensa LX6 processor, made with 40 nm technology). Individual CPU cores can be manipulated. Data and instructions can be stored in the 520 KB of on-chip SRAM. For example, the ESP32-Wrover SOC module has 4 MB of external SPI flash and an extra 8 MB of SPI PSRAM for use in custom applications (Pseudo-static RAM). Depending on the board type, we can employ varying amounts of SPI, I2S, I2C, CAN, UART, Ethernet MAC, and IR. A temperature sensor and a touch sensor are also included as standard equipment.



Fig. 1. ESP32 (Wi-Fi Module) microcontroller Chip

2.1.1 DHT22 (Temperature and Humidity Sensor)

DHT22 output calibrated digital signal utilizes exclusive digital-signal-collecting-technique and humidity sensing technology, assuring its reliability and stability. Its sensing elements are connected with 8-bit single-chip computer. Every sensor of this model is temperature compensated and calibrated in accurate calibration chamber and the calibration-coefficient is saved in type of programme in OTP memory, when the sensor is detecting, it will cite the coefficient from memory. Small size & low consumption & long transmission distance (20m) enable DHT22 to be suited in all kinds of harsh application occasions. Single-row packaged with four pins, making the connection very convenient.

DHT22 is specified with the following; operating voltage: 3.5V to 5.5V, operating current: [0.3mA (measuring), 60uA (stand by)], output serial data, temperature range from -40 degree Celsius to 80 degree Celsius, humidity ranges from 0% to 100%, resolution of temperature and humidity are both 16-bit, and the accuracy are +/- 0.5 degree Celsius and +/- 1%.

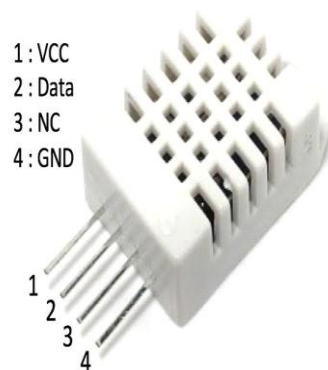

Fig. 2. DHT22

2.1.2 Tipping bucket

Using the tipping bucket, you can get a comprehensive picture of the amount of rain that has fallen. The diameter of the receiver is 200 millimeters (mm). The Tipping Bucket measures rainfall in increments of 0.2, 0.5, 1 mm, or 0.01 inch. A siphon could also be included (an optional feature that allows rain to flow at a steady rate to the tipping bucket mechanism regardless of rainfall intensity). Precipitation "flow rate" is controlled by this system. During periods of extremely heavy rainfall, this metering geometry ensures better levels of precision and repeatability. Tipping bucket gauges work by measuring the amount of water that falls into a small bucket. When the bucket is full, it tips over and empties. Precipitation volumes and rates are sent as the number of "tips" and the pace at which they happen. Tipping bucket gauges, on the other hand, are less expensive and require far less maintenance than weighing gauges. The performance of an inductive-magnetic proximity sensor may be impacted by the presence of surrounding ferromagnetic materials.

2.1.3 TSL2561 (light sensor)

The TSL2561 luminosity sensor is used to measure the sun radiation and is an advanced digital light sensor, ideal for use in a wide range of light situations. Compared to low cost CDS cells, this sensor is more precise, allowing for exact lux calculations and can be configured for different gain/timing ranges to detect light ranges from up to 0.1 - 40,000+ Lux on the fly. The best part of this sensor is that it contains both infrared and full spectrum diodes, that means you can separately measure infrared, full-spectrum or human-visible light. Most sensors can only detect one or the other, which does not accurately represent what human eyes see (since we cannot perceive the IR light that is detected by most photo diodes). The sensor has a digital (i2c) interface where you can select one of the three addresses. The built in ADC means you can use this with any microcontroller, even if it doesn't have analog inputs. The current draw is extremely low, so it's great for low power data-logging systems. about 0.5mA when actively sensing, and less than 15uA when in power down mode.



Fig. 3. Tipping buck



Fig. 4 Light Sensor (TSL2561)

2.2 Review of Related Work

Pauzi, et al (2020). The development of a weather reporting system based on the Internet of Things. Additionally, the device is used to determine the atmosphere's temperature, pressure, relative humidity, and altitude. Weather reporting is more precise than forecasting. Additionally, the data displayed can be viewed in the Blynk app, which can be downloaded from the Google Play or App stores.

Holovatyy [15] created an Internet of Things (IoT) weather monitoring system using an Arduino and an ESP8266 Wi-Fi module. Additionally, the device is used to determine the atmosphere's temperature, pressure, relative humidity, and altitude. The simulation and testing results for the IOT weather monitoring system demonstrated that the developed hardware and software operate correctly.

John [16] designed and built an IoT-based weather monitoring system for the purpose of Effectiveness Analytics. This device was built using sensors attached to a Raspberry Pi. In addition, carbon monoxide levels are being measured.

Srinivasa (2016), created an Internet of Things (IOT) weather monitoring system. The device was built to monitor weather conditions in a specific location and make the data available online. Various models are available for this device, which has a smart way of monitoring an environment and an efficient, low-cost embedded system.

IoT-based weather monitoring was developed by **Chaw et al. (2015)**. (IOT). A microcontroller interfaced with sensors and a GSM module sends data wirelessly to a remote server to keep tabs on environmental conditions like temperature and humidity over time. The data can be stored online, which can be used to forecast the weather and look at climate patterns in the future, as well as for other meteorological purposes.

Dinesh et al. (2018) created a weather reporting system based on the Internet of Things. An Android app is also available for easy access to the cloud-based data that this system uses to keep an eye on things like temperature, relative humidity, rain drops, and flames. There is a sufficient low-cost embedded system included in this system.

Kiran (2021) used the internet of things to create a weather reporting system. The system is not only used by farmers, but it is also used to monitor weather in rain forests and on volcanoes. Nobody is obligated to keep it in check. automated with the assistance of a Node MCU The Blynk app displays sensor data in real time. **Shiva Prakash (2021)** developed a real-time weather monitoring system using the Internet of Things. At a low cost, the device continuously monitors weather parameters.

Kavya Ladi (2017) developed an IoT-based weather reporting system to determine dynamic climatic parameters. It measures temperature, heat index, humidity, and raindrops, among other things. On any smart phone with an internet connection, there is an app that shows how ions form in real time. **A. F. Pauzi (2020)** developed a weather reporting system based on the Internet of Things. This device is not particularly adept at covering a large area, but it excels at wireless communication.

3. METHODOLOGY

This describes the methods used for the design of the hardware and software part, the main part of the hardware is the DHT22, TS2651 sensor

and how it interfaces with the microcontroller, display unit, the methodology consideration and specification of the weather reporting system were recorded. It is programmed using proteus to be precise. The microcontroller is program to receive signal from the sensors used once activated.

The system architecture consists of electrical and electronics component which are integrated to complete the design as listed below.

- i. ESP32 microcontroller
- ii. DHT22 sensor
- iii. TSL2651 sensor
- iv. Tipping Bucket
- v. LCD
- vi. Resistor
- vii. Capacitor
- viii. Battery
- ix. Solar Panel
- x. Voltage Regulator

3.1 Hardware Implementation of the Design

The system is a development of weather reporting with an ESP32 microcontroller. The ESP32 serves as the central microcontroller, and the sensors are linked to it via digital and analog pins. An ESP32 microcontroller receives readings from sensors in the environment and processes them before displaying their results on the ESP serial monitor. The sensor's data was shown on the LCD screen by the display unit. The solar power pack provides the voltage needed to run the LCD and the rest of the system. The block diagram of the design is shown in Figure.

The block diagram in the figure above shows the following units are integrated.

- i. Power supply unit
- ii. Microcontroller unit
- iii. Sensing unit
- iv. Display unit

3.1.1 Power supply unit

A stable source of voltage was used to power the ESP32 microcontroller. The battery is enough to supply the minimum input voltage for the system. The power supply unit is very important for all electronic circuits.

3.1.2 Microcontroller unit

The microcontroller unit can also be referred to as the processing unit of the weather reporting system, because it interfaces with all the components and sensors of the weather reporting system function. The microcontroller has an increase in the number of GPIO pins from 17 to 36; each pin is assigned a specific task to carry out. The ESP32 microcontroller is developed by Espressif. The board is equipped with sets of digital and analog input/output (I/O) pins.

3.1.3 Sensing unit

The Sensing unit of the weather reporting device serves as the input unit of the design. The tipping bucket which is used to measure the precipitation, DHT22 which is used to measure the temperature and humidity, TSL2651 which is used to measure the solar radiation i.e., the amount of sunlight. The sensing unit senses the signal and then sends it to the microprocessor for necessary action to take place.

3.1.4 Display unit

The display unit of the weather reporting device serves as part of the output unit of the design. 16x4 Character LCD Display was used for the display unit. 16x4 character-type liquid crystal display, is a kind of dot matrix module to show letters, numbers, graph, and characters and so on. It is composed of 16 rows and 4 columns dot matrix positions; each position can display one character. This LCD screen is equipped with an I2C adapter. The I2C is a type of serial bus, which uses two bidirectional lines, called SDA (Serial Data Line) and SCL (Serial Clock Line). Both must be connected via pulled-up resistors. The usage voltages are standard as 5V and 3.3V. The I2C adapter is already soldered onto the board, because of this, the wiring is quite easy. Only four pins are required to hook up; VCC, GND, SDA and SCL.

3.2 Design Analysis

The circuit diagram as shown in figure below was designed using Proteus professional software installed on a computer system which was run on Windows 10 Operating System. The simulated circuit diagram of design and the diagrammatical representation is shown in

Figure below, The ESP32 microcontroller has already been designed to operate without the use of a transformer. While other components like DC motor require 1.5V and the LEDs need 2V. The ESP32 board is designed locally in such a way that the microcontroller is able to interact with all the units present in the design of the weather reporting system. In designing the local ESP32 board, Vero board was used and the components listed in the system design were all used. The entire component was connected and they were able to interact with each other. The microcontroller takes the raw data and converts it into understandable and communicable information. The microcontroller sends the measured data to the cloud platform via the device Wi-Fi module.

3.3 Software Design Approach

The software design was implemented using a C compiler for ESP32 microchip. This compiler consists of an optimized C compiler program as well as improved functions for many microcontroller operations. The flowchart in figure below shows the implementation of the algorithm used in the programming of the ESP32 microcontroller and the source code is shown in the Fig.7.

3.3.1 Loading of code on ESP32 microcontroller

The code loading process of microcontroller is called dumping. The microcontroller only understands the machine language, which contains '0s or 1s'. There are various Software Programmers available in the market for loading the code to the microcontroller. Here are the steps to load the code onto the microcontroller.

BLOCK DIAGRAM FOR WEATHER STATION

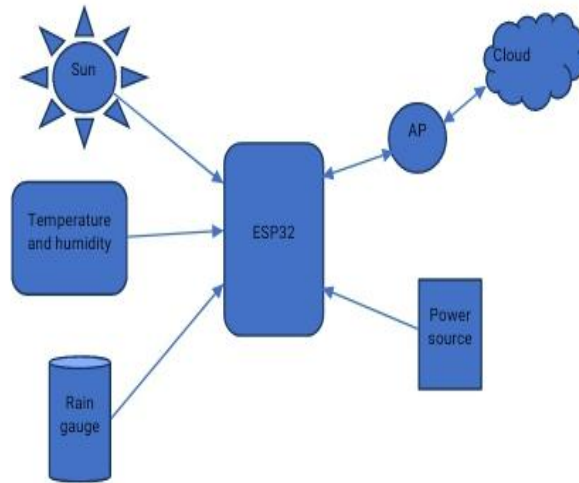

Fig. 5. Block diagram

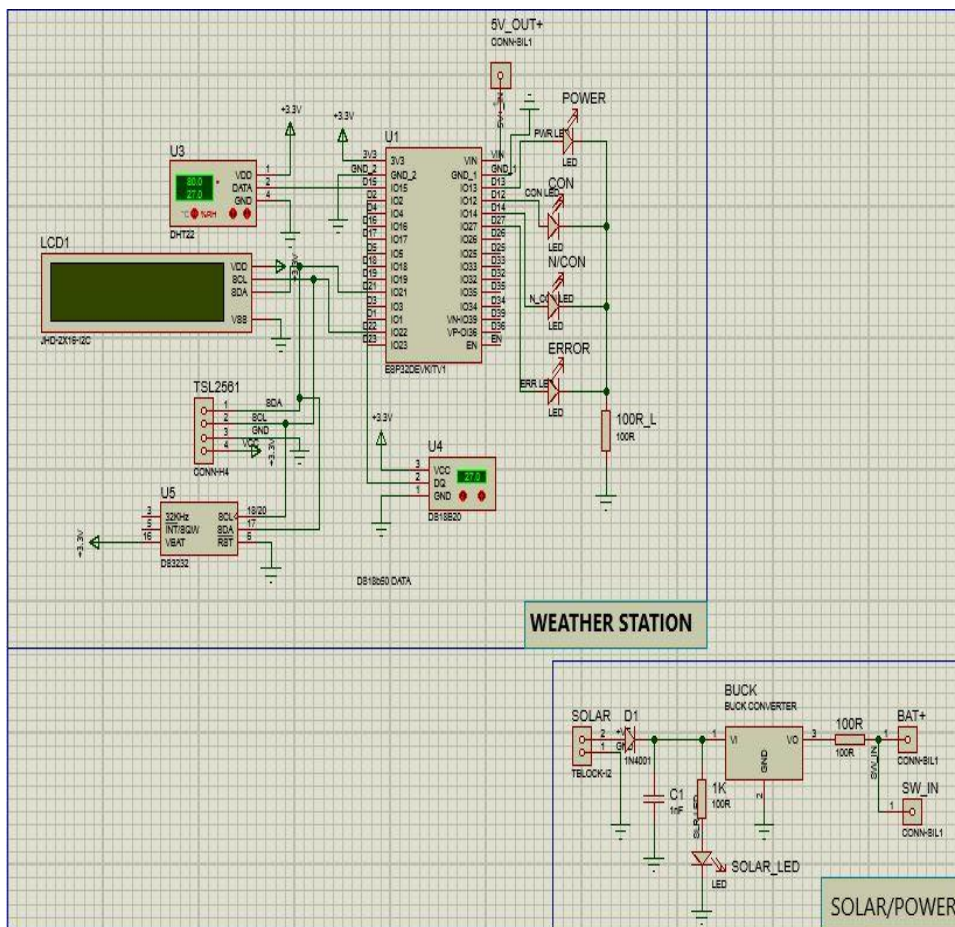

Fig. 6. Circuit diagram

3.4 System Flowchart

The flowchart of the system is shown in figure below, the algorithm of the weather reporting

system, comprises of the three main steps. First is to boot up the system, next is to measure the weather parameters from the connected sensors.

The data collected will be stored then uploaded automatically

- STEP 1: Power on the system
- STEP 2: Try connecting to Wi-Fi
- STEP 3: If the Wi-Fi is connected
- STEP 4: Get the weather parameters from the connected sensors
- STEP 5: Store the data received
- STEP 6: Upload the stored data
- STEP 7: Stop
- STEP 8: If the Wi-Fi is not connected
- STEP 9: Go to step 2

3.5 Testing

After the integration of various sub-unit of the complete prototype of the weather reporting system, the implementation of the circuit was tested with the help of Proteus software to ensure the proper connection of the circuit. The simulation was performed on Proteus software which has helped to know the circuit performance and find & rectify the errors of the program.

4. RESULTS AND DISCUSSION

4.1 Results

The device was tested in open spaces throughout the community and beyond (Fig. 1 and Fig. 2). Fig. 3 depicts the obtained uploaded results. Fig. 4 depicts the temperature dataset plots on a 2 minute interval. The humidity (Fig. 5), Luminous Intensity (Fig. 6), and precipitation graphs were created using the same method (Fig. 7). The test was performed in the evening.

4.2 Discussion

The result of simulation ensures that the circuit worked properly. The practical implementation of simulated circuit has been presented. In the circuit diagram ESP32 microcontroller was the main component used for controlling other sensors. DHT22, Tipping bucket, TSL2651 sensors were used as an input device for the designed system in other to sense the amount of temperature, humidity, light intensity, and precipitation. Immediately the signal is sent to the ESP32 microcontroller, the whole process automatically starts.

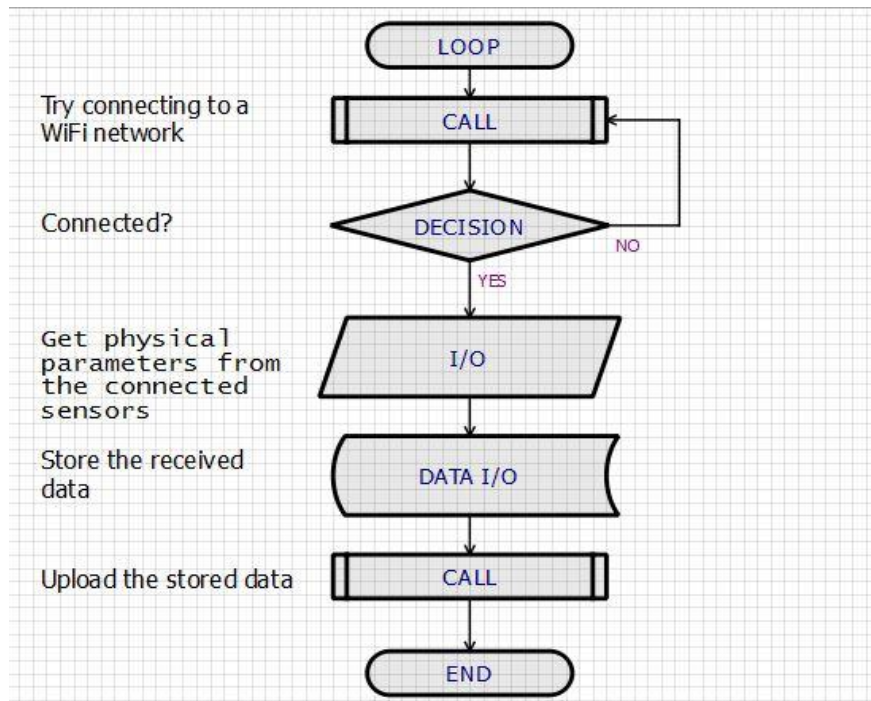

Fig. 7. Flowchart



Fig. 8. The developed device in open space during testing



Fig. 9. The front view of the developed device

entry_id	Minimum Temperature	Maximum Humidity	Maximum Temperature	Minimum Humidity	Precipitation	Luminous Intensity	Date
1	1.00	58.00	30.00	72.00			2021-
2	2.00	44.00	78.00	23.00			2021-
3	3.00	9.00	40.00	65.00			2021-
4	4.00	62.00	42.00	87.00			2021-
5	7.00	69.00	9.00	57.00			2021-
6	8.00	60.00	31.00	99.00			2021-
7	9.00	78.00	16.00	35.00			2021-
8	11.00	67.00	10.00	33.00			2021-
9	12.00	79.00	49.00	79.00			2021-
10	13.00	21.00	67.00	72.00			2021-

Fig. 10. The uploaded data from the device

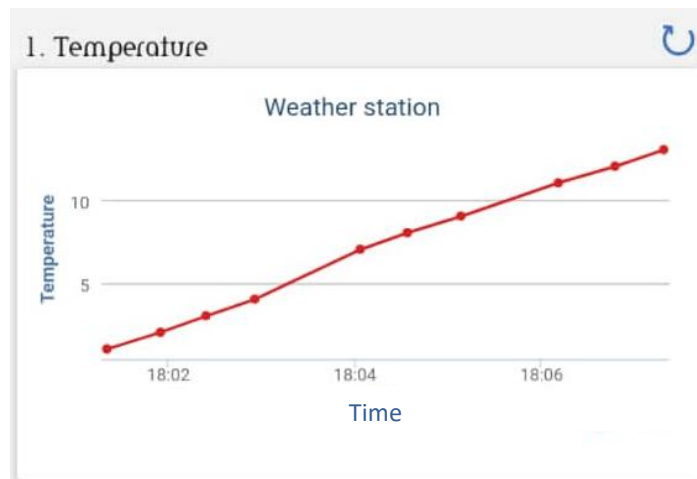

Fig. 11. Graphical representation of temperature

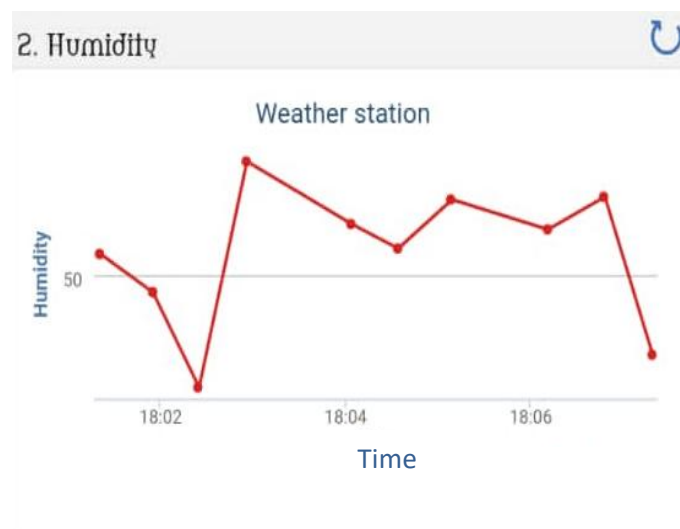

Fig. 12. Graphical Representation of Humidity



Fig. 13. Graphical Representation of Luminous Intensity



Fig. 14. Graphical representation of precipitation

The minimum and maximum temperatures and luminous intensity are among the six weather parameters measured by the developed intelligent weather device. According to the data collected, between 8 a.m. and 9 a.m., the temperature ranged between 20⁰ °C and 28 °C, while the maximum temperature ranged between 30⁰ °C and 35⁰ °C. There was also a notable decrease in the minimum humidity between 2:00 and 3:00 p.m., but an increase in the maximum humidity between 8:00 and 9:00 a.m. Compared to measurements taken between 8 and 9 am, values for the amount of light were significantly higher between 2 and 3 pm.

5. CONCLUSION AND RECOMMENDATION

5.1 Conclusion

Monitoring and displaying weather conditions around the world is made possible by the advanced system proposed. The Internet of Things (IoT) is the technology behind this, which is an advanced and efficient method for connecting things to the internet and connecting the entire world of things on a network. Anything from electronic gadgets and sensors to automotive electronic equipment can be found here. Temperature, humidity, wind speed and direction are all monitored by the system, as well as the amount of rain that has fallen. Real-time readings are shown on the system's LCD screen. Every hour and day, it records the previous day's data. It is possible to view this data on an LCD and to upload it to a web page, which will then display the sensor data in the form of graphs.

Thanks to the new system, you can access the most up-to-date data from anywhere in the world via the internet.

This describes a weather station that is low-cost, adaptable, and simple to use for a variety of purposes. This system's weather data can be accessed through a variety of mediums, including LCDs, smart devices, PCs, social media, and text message alerts.

5.2 Recommendation

An additional set of atmospheric parameters could be added to the current set of measurements taken by the intelligent weather station. Instead of using Wi-Fi, an intelligent weather station could benefit from the implementation of GPRS for the transfer of data from the weather station to the cloud. A larger solar panel, a larger rain gauge, and an aluminum tipping bucket make the developed system more efficient on a larger scale.

COMPETING INTERESTS

Authors have declared that no competing interests exist.

REFERENCES

1. Budi Setiyono RH, Sumardi. Measurement system of temperature, humidity and air pressure over 433 mhz radio frequency. An application on quadrotor. 2015;23.
2. Duchon CE, Essenberg GR. Comparative rainfall observations from pit and

- aboveground gauges with and without wind shields. *Water Resources Research*. 2001;37(12):3253–3263.
3. Gheith A, Rajamony R, Bohrer P, Agarwal K, Kistler M, Eagle BLW, Hambridge CA, Carter JB, Kaplinger T. Ibmbuemix mobile cloud services, *IBM Journal of Research and Development*. 2016;34. Available: http://www.bom.gov.au/inside/services_policy/pub_ag/aws.shtml.
 4. IoT based Data Logger System for weather monitoring using Wireless sensor networks, [online] Available: www.ijettjournal.org/2016/volume-32/number-2/IJETT32P213.pdf.
 5. Mihai B. About the Smart Weather Station. *Acta Universitatis Cibiniensis – Technical Series*. 2016;26–29.
 6. Nitu R, Wong K. Measurement of solid precipitation at automatic weather stations, challenges and opportunities. *Meteorological Service of Canada*, 4905 Dufferin St, Toronto, ON, M3H 5T4, Canada. 2010;308.
 7. Satyanarayana KNV, Reddy SRN, Suresh Varma KNV, Kanaka Raju P. Mobile APP & IOT Based Smart Weather Station. *International Journal of Electronics, Communication and Instrumentation Engineering Research and Development (IJEIERD)*. 2017;7(4):1–8.
 8. Savina M, Schappi B, Molnar P, Burlando P, Sevruk B. Comparison of a Tipping-Bucket and Electronic Weighing Precipitation Gage for Snow. *Atmospheric Research*. 2012;45-51.
 9. Sabatini F. Supporting climate change adaptation and biodiversity conservation in the Kailash landscape. Final report. Recommendations for the design of a system for acquisition, transmission and storage of Hydro-Meteorological data on the Kailash sacred landscape in Nepal. 2010;45.
 10. Karim F, Frihida A. Monitoring system using web of things in precision agriculture. *Procedia Computer Science*. 2017;402–409.
 11. Kodali RK, Sahu A. An IOT based weather information prototype using WeMos. *Proceedings 2nd International Conference Contemporary Computing Informatics, IC3I*. 2016;612–616.
 12. Li Song, Li Yong, Zhang Chao, Xia Wei. Application of Internet of things technology in meteorological service. *SME management and technology*. 2016;223.
 13. Sa-Ngiamvibool W, Angkawisittpan N, Nuan-On A, Photong C, Kangrang A. A rain gauge system using a capacitance sensor. *International Journal of Engineering and Technology*. 2013;5(4): 23.
 14. Saini H, Thakur A, Ahuja S, Sabharwal N, Kumar N. Arduino based automatic wireless weather station with remote graphical application and alerts. *3rd International Conference on Signal Processing and Integrated Networks (SPIN)*, Noida, India. 2016;605 – 609.
 15. Holovatyy, Andriy. Development of IoT Weather Monitoring System Based on Arduino and ESP8266 Wi-Fi Module. *IOP Conference Series: Materials Science and Engineering*. 2021;1016(1): 012014.
 16. Joe F, Joseph J. IOT Based Weather Monitoring System for Effective Analytics. *International Journal of Engineering and Advanced Technology (IJEAT)*. 2019;311–315.