

EFFECT OF MEMBRANE FOULING ON CLARIFICATION OF POMEGRANATE JUICE

Abstract

Pomegranate (*Punicagranatum* L., Punicaceae) is the most popular tropical non-citrus fruits, mainly because of their attractive aroma, refreshing flavour and Brix/acid ratio. The research was carried out on the physicochemical analysis and membrane clarification of pomegranate juice after pretreatment. Pretreatment of pomegranate juice was performed using egg albumin with different concentrations and observed that 2 g/L concentration gave effective removal of colloidal substances of both juices. Membrane processing of pomegranate juice was performed with different pore size membranes, transmembrane pressures, flow rates and the Coefficient of determination (R^2) values was analysed to validate fouling data using Hermia's analogy. The Coefficient of determination (R^2) values for gel layer model were in the range of 0.804 to 0.977 for 0.2 μm pore size membrane when pomegranate juice was filtered. R^2 values suggested intermediate pore blocking followed by gel layer formation.

Keywords: Membrane clarification, Egg albumin, colloidal substances, Fouling, Coefficient of determination

INTRODUCTION

Pomegranate is an important fruit crop grown in India. It is originated in Iran and extensive pomegranate farming is done in the Mediterranean countries like Spain, Morocco, Egypt, Iran, Afghanistan, and Baluchistan. India ranks first in pomegranate cultivation in the world. Ganesh, Bhagwa, Ruby, Arakta and Mridula are the important commercial cultivars. Maharashtra is leading with 147.9 thousand ha area with annual production of 1789 thousand MT and productivity of 12.10 MT/Ha. Andhra Pradesh and Telangana states record the productivity of pomegranate with 14.69 and 13.36 MT/Ha, respectively. India ranks sixth in the production of pineapple among the world countries.

Pomegranate (*Punicagranatum* L., Punicaceae) is the most popular tropical non-citrus fruits, mainly because of their attractive aroma, refreshing flavour and Brix/acid ratio. This juice have been used in fruit based beverages individually, in the form of mixture or combined with other fruit juices. As an ingredient, the concentrated juice from pomegranate blends well with other aromas of fruits resulting in a pleasant product with a competitive market price. Pomegranate, mainly produced in the middle east, have a number of nutritional and health benefits and is a potential source of anthocyanins, ellagic acid, phytoestrogenic flavonoids, tannins and organic acids, some of which are antioxidants. Further, as reported in biological studies, pomegranate juice is rich in anti-atherosclerotic and anti-atherogenic compounds which have been shown to reduce blood pressure and low density lipoprotein oxidation (Aviram and Dornfeld, 2001). Due to these characteristics and increasing public awareness about nutritional food, the demand for the pomegranate fruit has significantly increased in the last years. Consequently, many industries producing pomegranate fruit juice as well as pharmaceutical companies extracting health beneficial compounds from the fruits have been developed.

There is a worldwide increasing tendency for the consumption of tropical fruits, juices and fruit drinks due to the interest in ready to consume healthy products. Fruit juices are liquid foods that provide vitamins, sugars, mineral compounds and water. Consumers have individual preferences for specific appearance, consistency and flavor characteristics. Traditional methods of processing fruits limit the possibility to retain freshness as much as possible and its health-beneficial compounds. For instance, conventional juice clarification processes are based on the use of clarifying agents (gelatin, bentonite, diatomaceous earth, etc.) which create serious problems on the juice quality and freshness. Similarly, the concentration of fruit juices by thermal evaporation results in color degradation and reduction of most thermally sensitive compounds. Membrane technology is an alternative to produce a juice with good nutritional characteristics as it does not destroy the vitamins and other nutrients. It is also an alternative because of its operational advantages such as mild temperature, ease of scale-up and simplicity.

Introduction of membrane processing enables production of additive-free juices with high quality and natural fresh like taste. Juice clarification, stabilization, depectinization and concentration are typical steps in which membrane processes such

as microfiltration (MF), ultrafiltration (UF), nanofiltration (NF) and reverse osmosis (RO) can be potentially utilized. Clarification based on membrane processes, particularly UF and MF, have replaced conventional clarification, resulting in elimination of chemical clarifying agents and simplified process for continuous production. Purpose of the membrane processing is to remove suspended solids as well as haze-inducing and turbidity causing substances to obtain a clear juice after storage.

The disadvantage of membrane filtration is the decline in permeate flux due to membrane fouling, caused by the retention of some feed components on the membrane surface or within membrane pores. During filtration of pulpy juices, fouling is generally caused by pectins, tannins, proteins, starch, hemicellulose and cellulose. Therefore, it is important to minimise fouling using pretreatment prior to membrane filtration.

There have been a few studies on membrane filtration in fruit juice processing. There is a little understanding in literature on types and causes of fouling during MF and UF of fruit juices. The solute particles convected to the membrane surface generally initiate fouling. Potential source of particles are pectin, protein, phenolic compounds etc. It is not clear how different pore size membranes, transmembrane pressures and feed flow velocities, as well as the pretreatment of the fruit juice affect fouling.

Keeping in view of the above points, a study was undertaken on membrane fouling while clarification of pomegranate juice after pretreatment with egg albumin.

MATERIAL AND METHODS

Pomegranate of (cv. *Ganesh*) variety were obtained from local market, Bapatla, Guntur dist. Andhra Pradesh. These varieties were chosen as a good juice yielder as preferred by many juice processors and vendors. Sodium Benzoate, egg albumin powder, glass bottles of 250 mL were procured from National Scientific, Guntur, Andhra Pradesh. The fruits procured were properly sorted to discard fruits of mechanical damage while transportation. Pomegranate fruits were peeled, seeds were collected and juice was extracted.

PRETREATMENT ON AGGREGATION AND CLARIFICATION OF POMEGRANATE JUICE

The pomegranate juice of was used to determine the effect of pretreatment on aggregation and clarification parameters. The pretreatment was performed using a fining agent called egg albumin. The juice was subjected to four concentration levels *i.e.*, 0.25, 0.5, 1 and 2 g/L and effect of pretreatment was analysed. After the collection of juice, the egg albumin powder was added and mixed thoroughly. The juice samples were muslin cloth filtered and centrifuged at 4000 rpm (2147 g) for 5 min (Domingues et al 2011). The supernatant was used for biochemical quality analysis to determine the effect of pretreatment. The concentration of egg albumin which resulted in better clarification was determined by biochemical quality analysis. This concentration was subsequently used for pretreatment of both pineapple and pomegranate juices in all the experiments. The pretreatment was performed to remove the colloidal substances present in the juices. Colloids can decrease the permeate flux during filtration of the juice due to presence of pectinases, cellulase, hemicellulase, xylanase, carbohydrase, glucanase or arabinose. Removal of aggregates of these species via pretreatment may increase the permeate flux due to the reduction in the size of the particles and the subsequent decrease in viscosity (Valero et al 2014).

MEMBRANE CLARIFICATION OF POMEGRANATE JUICE

Membrane clarification (MF and UF) of pomegranate juice after pretreatment was carried out at Dr. N.T.R. College of Agricultural Engineering, Bapatla in hollow fibre membrane module setup (Model: HFM – 01, Technoquips Separation Equipments, Kharagpur). The term membrane processing in this thesis is essentially clarification of juices using membranes.

Hollow Fibre Membrane Module Setup

The schematic of hollow fiber membrane set up is shown in Fig. 1 and Plate 1. The heart of the set up is the hollow fiber module (F). The feed is drawn by the booster pump (C) and fed to the module by 6 mm polyurethane tube via a Perspex flange. Two pressure gauges in the range of 0 to 60 psi (4.1364 bar) are attached to the upstream and downstream of the module. A $\frac{3}{4}$ -inch needle valve (J) of stainless steel has been fitted in the retentate line after the module. This valve is used for fine tuning of pressure and flow rate through the module. A rotameter (K) of range 0 to 50 L/h is attached to the retentate line and the retentate stream is recycled back to the feed tank (A). A by pass line is connected from the pump to the feed tank and a $\frac{1}{2}$ -inch stainless steel needle valve

(B) is attached to the bypass line. The permeate flows through a 5 mm polyurethane pipe into permeate collector (G). By controlling the bypass valve (B) and retentate valve (J), one can control the flow rate and the transmembrane pressure drop across the module, independently. The transmembrane pressure drop is the arithmetic average of the readings in the pressure gauges E and I. The physical dimension of the set up is 70 mm in length, 48 mm in width and 65 mm in height. The weight of the set up is approximately 10 kg. One power point of domestic line 220 V is required to run the pump.

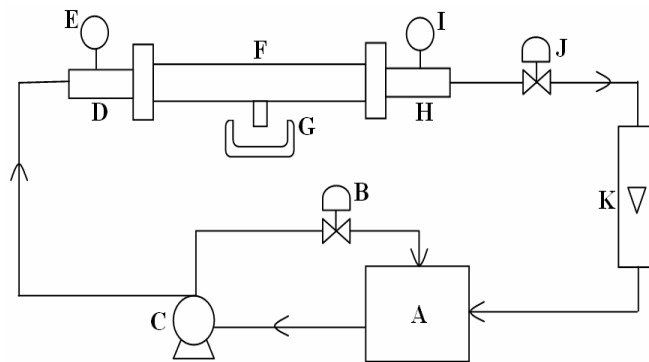

Fig. 1 Schematic diagram of the hollow fibre membrane module setup

where,

A : Feed tank, B : Bypass valve, C : Booster pump, D : Short piece, E : Upstream pressure gauge (0 – 4.21 kg/cm² (60 psi)), F : Hollow fibre module, G : Permeate collector, H : Short piece, I : Downstream pressure gauge (0 – 4.21 kg/cm²(60 psi)), J : Pressure valve (Needle type), K : Rotameter (0 – 50 Lph)



Plate 1Hollow fibre membrane setup

Membrane processing of pomegranate juice was carried out in the membrane module setup with different hollow fibre cartridges. The container was filled with 250

mL of juice. The operation was done in total recycle mode. The suction, retentate, by-pass lines were kept in feed solution and continuous operation was carried out. The permeate was collected at permeate line separately. All microfiltration (MF) and ultrafiltration (UF) experiments were carried out at transmembrane pressures (TMPs) of 0.3447 bar (5 psi), 0.6894 bar (10 psi), 1.0342 bar (15 psi) and 1.3789 bar (20 psi). The pore sizes of hollow fibre cartridges used for microfiltration and ultrafiltration experiments were 0.1 and 0.2 μm and 120, 70, 44 and 120 kDa (MWCO), respectively. The permeate was collected at regular intervals of time and tabulated. Initially the membranes were compacted at 1.0342 bar 15 psi, 30 Lph with distilled water for 2 hours in total recycle mode. Further, pure water flux data was collected both for MF and UF membranes using distilled water. After each run, the set up was flushed with distilled water and then cleaned with 0.1 N hydrochloric acid (HCl) for 30 mins in total recycle mode according to the washing protocol given by the manufacturer. After thorough washing, the permeability of the cartridges was analysed to measure the change in permeability of the hollow fibres. All the experiments were conducted in triplicate at room temperatures (30 ± 2 °C). After every experiment, the membranes were cleaned properly and stored in the 1% formalin solution for future use.

The permeate flux was calculated as

$$J^* = \left(\frac{1}{A}\right) \times \left(\frac{dv}{dt}\right) \quad \dots\dots 6$$

- Where,
- J^* = Permeate flux (L/h m^2)
 - A = Area of the membrane (m^2)
 - dv = Volume of flow rate (L)
 - dt = Time of flow rate (h)

The permeate collected was stored in glass bottles. The experiments were performed according to the different conditions laid down in the table 1 and analysed to obtain high permeate flux.

Table 1 Operating variables for microfiltration and ultrafiltration of pomegranate juices

Operating variables	
Membrane poresizes:	MF - 0.1 and 0.2 μm UF – 120, 70, 44 and 10 kDa

Transmembrane pressures (TMP):	0.3447 bar (5 psi), 0.6894 bar (10 psi), 1.0342 bar (15 psi) and 1.3789 bar (20 psi)
Crossflow Velocities/ Feed flow rates:	0.024 m/s (20 Lph), 0.037 m/s (30 Lph) and 0.049 m/s (40 Lph)

IDENTIFICATION OF FOULING MECHANISMS

In this work, Hermia's empirical models were used to evaluate the fouling phenomena occurring in MF and UF of both pineapple and pomegranate fruit juices. The flux data was fit into existing fouling models to elucidate fouling mechanisms during membrane processing.

Membrane processing is a non-thermal process. The juices without any thermal treatment and added preservatives can be potentially produced. However, an important limitation in the performance of membrane processes is decline in permeate flux due to the transient build-up of a layer of rejected species at the membrane upstream interface. The general effect of these phenomena, known as concentration polarization, leads to rapid permeate flux decay during the early period of filtration, followed by a long and gradual flux decline towards a steady, or nearly-steady-state limit value (Oliveira *et al.*, 2011).

The reduction in permeate flux can be divided into two separate parts: First, concentration polarization which affects the selectivity of a membrane. Concentration polarization leads to an accumulation of particles or solutes in a mass transfer boundary layer adjacent to the membrane surface. Dissolved molecules accumulating at the surface reduce the solvent activity and this reduces the solvent flow through the membrane. This can be represented as a reduction in the effective transmembrane pressure (TMP) driving force due to an osmotic pressure difference between the filtrate and the feed solution immediately adjacent to the membrane surface. This phenomenon is inevitable, but is usually reversible with changing TMP. Second, there is fouling, that is to say a buildup of material (e.g., adsorbed macromolecules, in-pore fouling, gels, or deposited particles on or in the

membrane surface). There are four modes of fouling categorized according to different blockage mechanisms by Grace (1956).

- a) Cake filtration
- b) Intermediate blocking
- c) Standard blocking
- d) Complete blocking

Based on hypothesis depicted in Fig. 2 these mechanisms may occur individually or in some cases in combination of two or more modes. For each mechanism, a mathematical model has been developed to predict decline in permeate flux and its limiting value due to fouling.

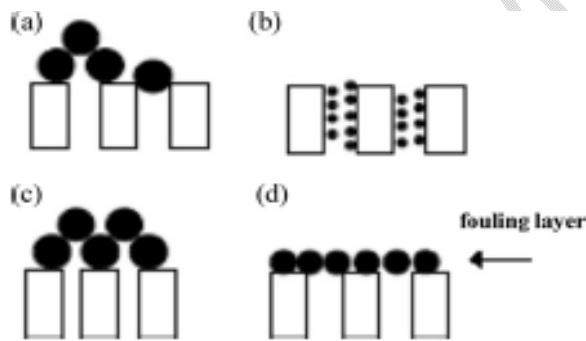

Fig. 2 Scheme of fouling mechanism: (a) cake filtration (b) intermediate pore blocking (c) standard pore blocking (d) complete pore blocking

The mode of flux decline during filtration fluids can be identified (Hermia, 1982; Raziet *al.*, 2012):

$$\frac{d^2t}{dV^2} = \beta \left\{ \frac{dt}{dV} \right\}^n$$

where, t = Cumulative time of the instant measuring the cumulative volume (V), and β and n = Parameter constants

RESULTS AND DISCUSSIONS

In this work, Hermia's empirical models as elucidated were used to evaluate the fouling phenomena occurring in MF and UF of both pineapple and pomegranate fruit juices. The flux data was fit into existing fouling models to elucidate fouling mechanisms during membrane processing.

MF and UF of pomegranate juice

(a) 0.2 μm pore size membrane

The plots related to the fouling phenomena of 0.2 μm pore size membrane were shown in Fig. 3. The plot of $1/J^2$ with time which represents the gel layer formation was presented in Fig. 3(a). The plot $\ln(J)$ with time represents complete pore blocking (CPB) was shown in Fig. 3(b). Similarly, the intermediate pore blocking (IPB) which can be explained by $\frac{1}{J}$ with time plot and the standard pore blocking can be explained by $\frac{1}{\sqrt{J}}$ with time were shown in Fig. 3(c) and Fig. 3(d) respectively. Statistical parameters such as sum of squares (SS), R^2 and Standard error were tabulated (Table 2). The different plots and their R^2 values indicated probable fouling mechanism which is predominant. The prevalent fouling can be elucidated by high R^2 values. From the Table. 2, it was evident that high R^2 values were obtained for gel layer formation. The R^2 values were in the range of 0.804 to 0.977. It was observed that gel layer formed upon prolonged duration of MF with pomegranate juice (Rai *et al.*, 2010; and Shirato *et al.*, 1991). The IPB values ranged from 0.787 to 0.896. The coefficient of determination (R^2) values were less for both SPB and CPB. Poor fitting was observed for both the models. This might have occurred because of the larger pore size of membrane where solid particles might have passed easily through membrane initially causing some type of pore fouling. Later on prolonged passage of feed would have formed surface layer. Further convective transport of solute particles on to the membrane would have consolidated the surface layer making it concentrated gel layer.

(b) 0.1 μm pore size membrane

The membrane processing of pomegranate juice was also carried out with 0.1 μm pore size membrane and data was recorded (Fig. 4 and Table. 2). The coefficient of determination values (R^2) values were high for gel layer model as it was observed for MF with 0.2 μm pore size membrane. The values ranged from 0.808 to 0.974 and 0.756 to 0.933 for gel layer model and IPB, respectively. From the values, it was evident that the fouling might have occurred because of gel layer formation and intermediate pore blocking. In prior case, 0.2 μm membrane the IPB was not predominant but while clarification with 0.1 μm membrane IPB was prevalent. This mechanism was because of the smaller pore size of membrane which upon prolonged filtration some solids might have adhered to the pore walls which in turn blocked.

Similar results were obtained by Bowen *et al.*(1995). The R^2 values for SPB and IPB were recorded to be low due to poor fitting of permeate flux data. The standard error values were recorded to be low both for gel layer formation and intermediate pore blocking.

UNDER PEER REVIEW

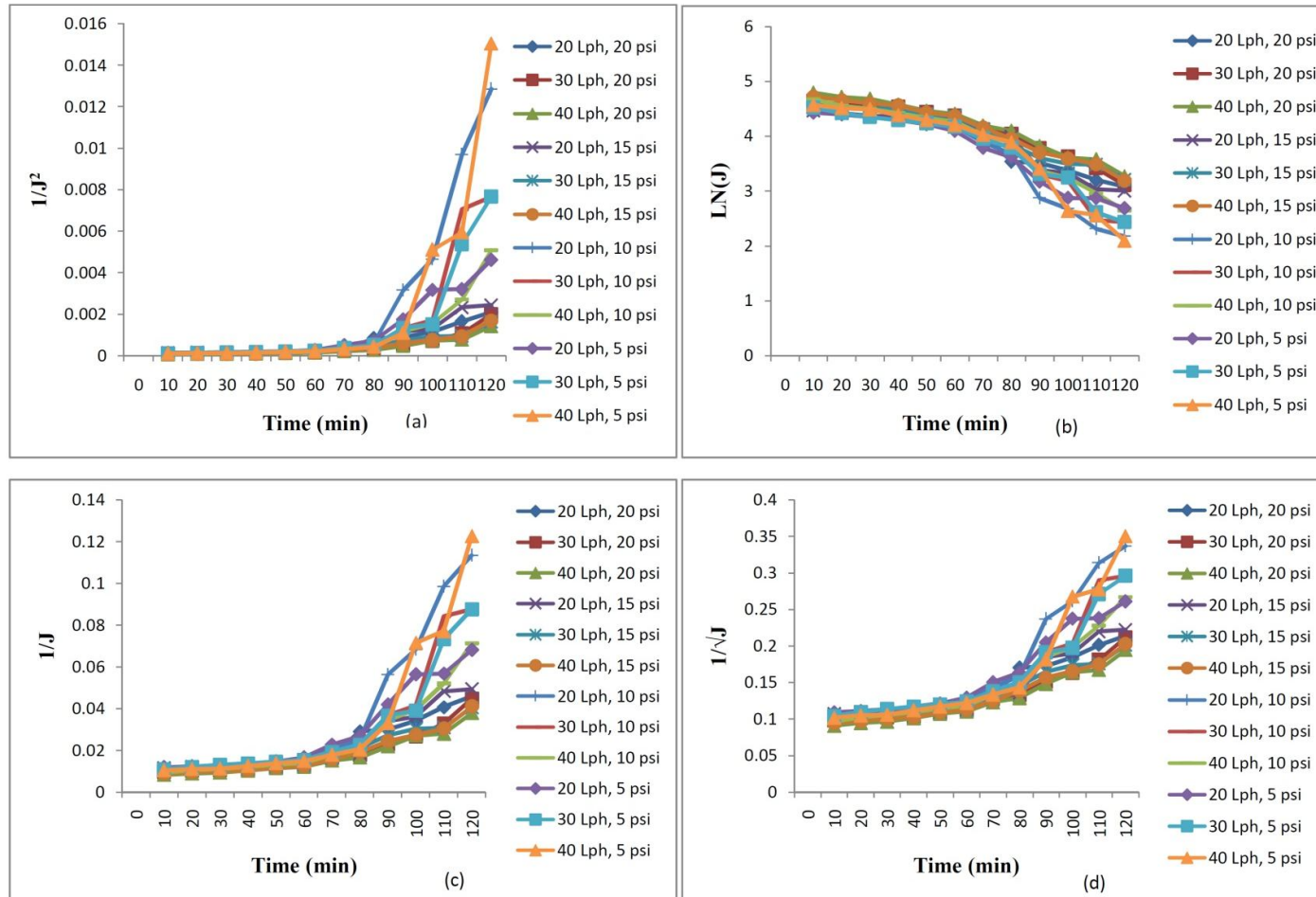

Fig. 3 Plots of characteristic parameters fit to various fouling models in MF of pomegranate juice through 0.2 μm pore size membrane for (a) gel layer formation, (b) complete pore blocking, (c) standard pore blocking, (d) intermediate pore blocking

Table 2. Statistical parameters for fitting of the fouling models to experimental data of MF of pomegranate juice

Membrane Pore size	TMP (psi) and Flow rate (Lph)	Sum of squares (SS)				R ²				Std error			
		Gel	CPB	IPB	SPB	Gel	CPB	IPB	SPB	Gel	CPB	IPB	SPB
0.2 μm	20 Lph, 20 psi	0.083	0.163	0.002	0.033	0.975	0.699	0.896	0.848	0.000265	1.31065	0.00348	0.02001
	30 Lph, 20 psi	0.024	1.426	0.001	0.025	0.914	0.625	0.829	0.704	0.000323	1.3387	0.00934	0.0318
	40 Lph, 20 psi	0.015	1.545	0.001	0.023	0.900	0.721	0.884	0.726	0.000831	1.30451	0.00381	0.02536
	20 Lph, 15 psi	0.062	0.354	0.002	0.034	0.855	0.787	0.821	0.606	0.001674	1.28628	0.01374	0.03698
	30 Lph, 15 psi	0.022	1.556	0.001	0.025	0.847	0.814	0.885	0.604	0.002440	1.27014	0.00379	0.04057
	40 Lph, 15 psi	0.020	1.166	0.001	0.025	0.977	0.841	0.883	0.729	0.000225	1.26727	0.00448	0.02251
	20 Lph, 10 psi	0.013	6.096	0.012	0.094	0.860	0.584	0.845	0.749	0.000977	1.34369	0.00814	0.02067
	30 Lph, 10 psi	0.461	2.126	0.007	0.066	0.851	0.793	0.810	0.735	0.001865	1.27054	0.01849	0.02213
	40 Lph, 10 psi	0.156	0.434	0.004	0.066	0.905	0.785	0.787	0.661	0.000479	1.28935	0.02088	0.03267
	20 Lph, 5 psi	0.207	0.537	0.005	0.053	0.906	0.762	0.855	0.732	0.000347	1.29746	0.00648	0.02233
	30 Lph, 5 psi	0.370	0.904	0.006	0.059	0.804	0.567	0.817	0.727	0.003207	1.37601	0.01501	0.02524
	40 Lph, 5 psi	0.011	4.890	0.011	0.085	0.826	0.659	0.863	0.709	0.002727	1.3227	0.00486	0.02594
0.1 μm	20 Lph, 20 psi	0.120	0.534	0.004	0.049	0.858	0.676	0.728	0.784	0.000909	1.28448	0.01731	0.02154
	30 Lph, 20 psi	0.026	1.451	0.001	0.026	0.942	0.723	0.818	0.799	0.000359	1.25686	0.01098	0.02016
	40 Lph, 20 psi	0.014	1.381	0.001	0.024	0.808	0.529	0.911	0.727	0.002804	1.29732	0.00333	0.02297
	20 Lph, 15 psi	0.053	0.802	0.002	0.032	0.968	0.755	0.896	0.711	0.000173	1.23158	0.00383	0.02448
	30 Lph, 15 psi	0.037	0.446	0.002	0.031	0.820	0.781	0.933	0.665	0.001635	1.21828	0.00303	0.0254
	40 Lph, 15 psi	0.025	1.381	0.001	0.026	0.922	0.724	0.890	0.617	0.000404	1.25163	0.00452	0.0268
	20 Lph, 10 psi	0.028	1.299	0.020	0.130	0.941	0.840	0.848	0.708	0.000374	1.2116	0.0051	0.02458
	30 Lph, 10 psi	0.072	5.143	0.010	0.084	0.837	0.614	0.840	0.702	0.001312	1.29624	0.01063	0.02475
	40 Lph, 10 psi	0.021	0.231	0.004	0.049	0.879	0.510	0.756	0.749	0.000598	1.30646	0.01229	0.02177
	20 Lph, 5 psi	0.007	3.279	0.010	0.080	0.974	0.699	0.866	0.716	0.000167	1.27764	0.00496	0.02297
	30 Lph, 5 psi	0.017	0.005	0.004	0.046	0.954	0.709	0.844	0.530	0.000277	1.26389	0.00655	0.03301
	40 Lph, 5 psi	0.085	0.122	0.003	0.038	0.956	0.701	0.841	0.534	0.000257	1.2702	0.00774	0.02744

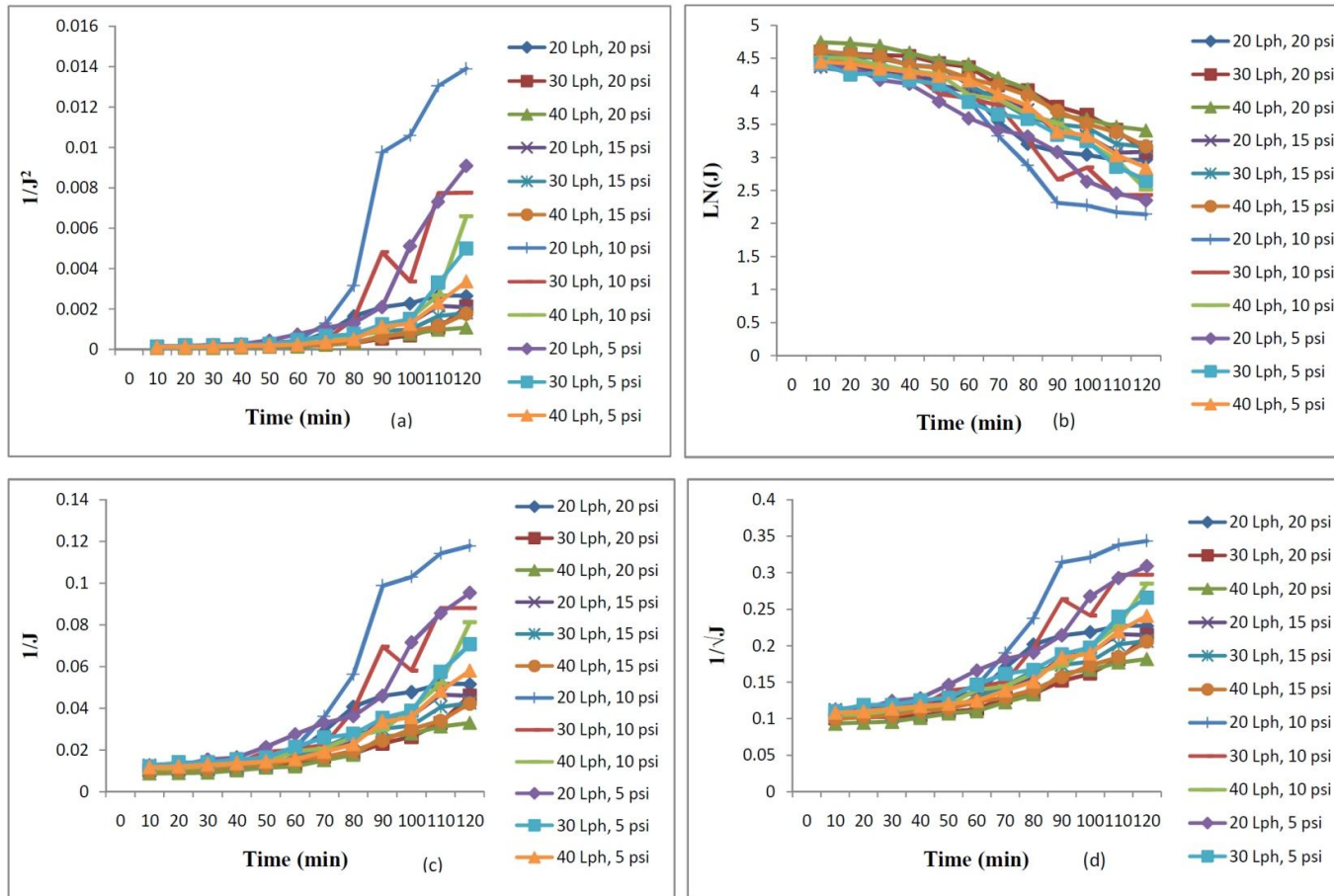

Fig. 4 Plots of characteristic parameters fit to various fouling models in MF of pomegranate juice through 0.1 μm pore size membrane for (a) gel layer formation, (b) complete pore blocking, (c) standard pore blocking, (d) intermediate pore blocking

(c) 120 kDa MWCO membrane

The values of coefficient of determination (R^2) for gel layer formation were in the range of 0.807 to 0.964 (Fig. 5 and Table 3). The values of R^2 for gel layer formation are predominant during membrane processing of pomegranate juice. It was also observed that IPB also gave good fitting of permeate flux data which proved that intermediate pore blocking also existed. The range of R^2 values for IPB were 0.840 to 0.978. The SPB and CPB gave poor fitting for permeate flux data which explained that fouling was not because of them. Some of the colloidal substances might have clogged on the pore walls and on the surface of membrane causing intermediate pore blocking followed by gel layer formation. Similar results were observed by Rai *et al.*, (2010).

(d) 70 kDa MWCO membrane

Similar trends were observed when UF of pomegranate juice processing was carried out with 70 kDa MWCO membrane (Fig. 6 and Table 3). The range of coefficient of determination (R^2) values for gel layer model were 0.818 to 0.971. Similarly, the R^2 values for IPB were in the range of 0.801 to 0.978. It was evident from permeate flux data that intermediate pore blocking followed by gel layer formation were predominant fouling mechanisms. Both the other models *i.e.*, SPB and CPB gave poor fitting values for permeate flux data.

The reasons for both the fouling mechanisms might be because of the very narrow pore size of the membrane which caused clogging of pores. However, the most predominant fouling parameters can be taken as gel layer formation and intermediate pore blocking.

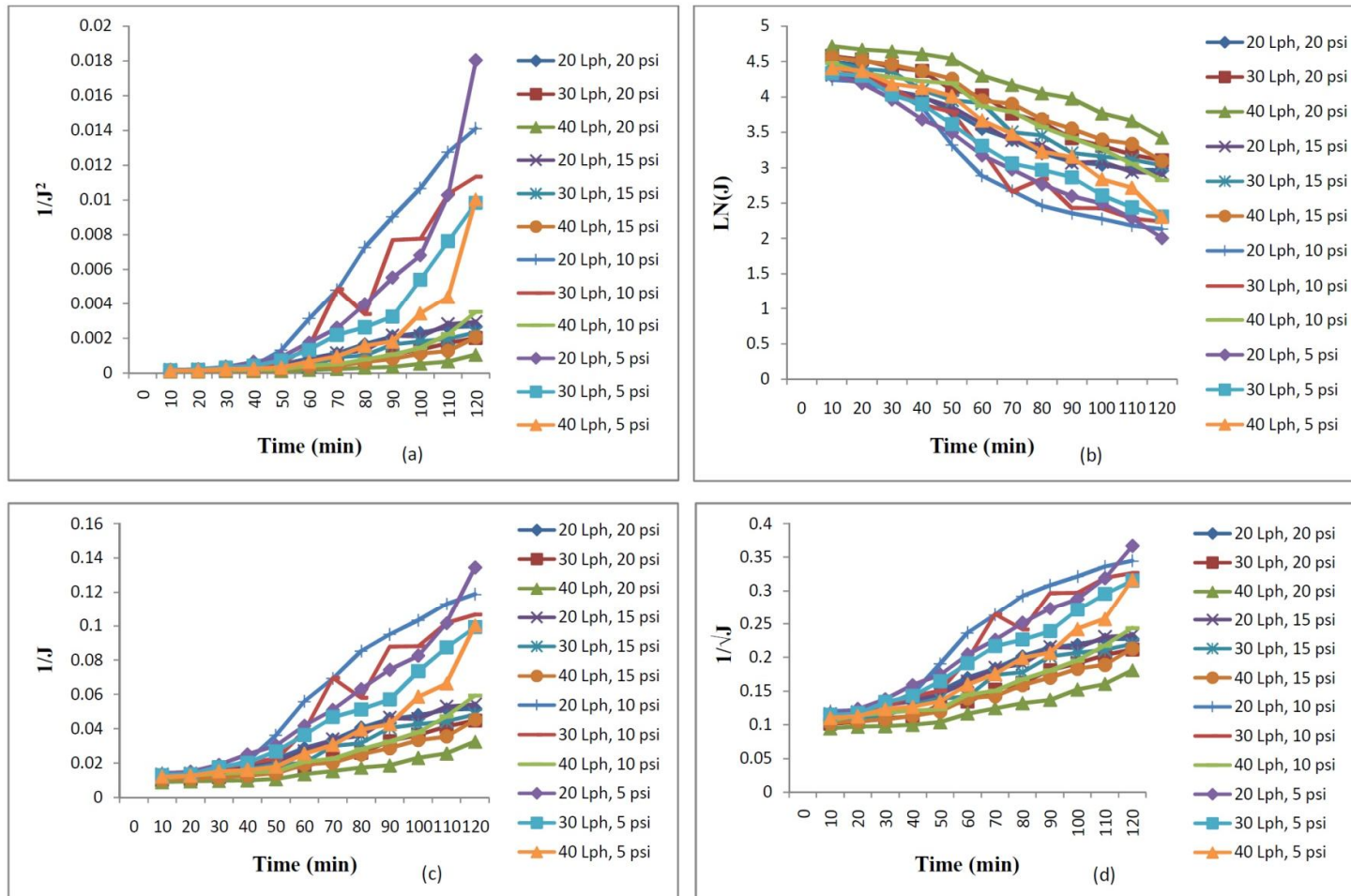

Fig. 5 Plots of characteristic parameters fit to various fouling models in UF of pomegranate juice through 120 kDa MWCO for membrane (a) gel layer formation, (b) complete pore blocking, (c) standard pore blocking, (d) intermediate pore blocking

Table 3. Statistical parameters for fitting of the fouling models to experimental data of UF of pomegranate juice

Membrane MWCO	TMP (psi) and Flow rate (Lph)	Sum of squares (SS)				R ²				Std Error			
		Gel	CPB	IPB	SPB	Gel	CPB	IPB	SPB	Gel	CPB	IPB	SPB
120 kDa	20 Lph, 20 psi	0.011	0.017	0.004	0.044	0.934	0.608	0.978	0.594	0.00026	1.24329	0.00254	0.02522
	30 Lph, 20 psi	0.046	0.216	0.002	0.033	0.850	0.895	0.958	0.862	0.00166	1.15769	0.00304	0.02072
	40 Lph, 20 psi	0.008	3.682	0.001	0.018	0.854	0.692	0.902	0.678	0.00148	1.22264	0.0097	0.02436
	20 Lph, 15 psi	0.012	0.057	0.003	0.042	0.901	0.605	0.968	0.543	0.00029	1.28308	0.00268	0.02643
	30 Lph, 15 psi	0.072	0.068	0.003	0.038	0.896	0.704	0.964	0.754	0.00033	1.20712	0.00288	0.02158
	40 Lph, 15 psi	0.035	0.685	0.002	0.030	0.924	0.652	0.937	0.739	0.00026	1.23409	0.00536	0.02212
	20 Lph, 10 psi	0.030	1.066	0.021	0.129	0.899	0.800	0.967	0.839	0.00028	1.18055	0.0028	0.02099
	30 Lph, 10 psi	0.018	0.936	0.016	0.114	0.842	0.820	0.935	0.734	0.00168	1.16614	0.00685	0.02308
	40 Lph, 10 psi	0.092	0.089	0.003	0.039	0.964	0.703	0.893	0.753	0.00015	1.2212	0.01085	0.02173
	20 Lph, 5 psi	0.023	0.694	0.017	0.112	0.696	0.725	0.924	0.550	0.0029	1.18488	0.00773	0.02568
	30 Lph, 5 psi	0.093	3.761	0.011	0.086	0.807	0.648	0.950	0.638	0.00184	1.2423	0.00317	0.02489
40 Lph, 5 psi	0.057	2.116	0.008	0.071	0.873	0.773	0.840	0.704	0.00057	1.18155	0.01108	0.02334	
70 kDa	20 Lph, 20 psi	0.014	0.699	0.003	0.039	0.971	0.747	0.926	0.731	0.00019	1.12855	0.00475	0.02916
	30 Lph, 20 psi	0.090	0.114	0.003	0.039	0.936	0.701	0.981	0.739	0.00023	1.21847	0.0038	0.02913
	40 Lph, 20 psi	0.047	0.369	0.002	0.032	0.868	0.786	0.887	0.648	0.00164	1.05694	0.00841	0.03389
	20 Lph, 15 psi	0.018	0.358	0.004	0.042	0.969	0.778	0.956	0.769	0.00019	1.09436	0.00461	0.02694
	30 Lph, 15 psi	0.095	0.137	0.003	0.039	0.955	0.899	0.946	0.797	0.00022	1.01109	0.00464	0.02476
	40 Lph, 15 psi	0.013	0.003	0.003	0.043	0.819	0.709	0.801	0.646	0.00183	1.16699	0.01392	0.04797
	20 Lph, 10 psi	0.027	2.479	0.017	0.101	0.872	0.674	0.881	0.782	0.00137	1.23447	0.00916	0.02624
	30 Lph, 10 psi	0.077	0.968	0.009	0.072	0.871	0.734	0.900	0.753	0.00159	1.1526	0.00806	0.02848
	40 Lph, 10 psi	0.035	0.370	0.006	0.056	0.818	0.785	0.876	0.750	0.00283	1.06332	0.01106	0.02849
	20 Lph, 5 psi	0.055	0.677	0.026	0.134	0.849	0.540	0.978	0.729	0.00179	1.25069	0.00388	0.03205
	30 Lph, 5 psi	0.024	0.470	0.017	0.107	0.877	0.533	0.985	0.824	0.00043	1.2571	0.00217	0.02174
40 Lph, 5 psi	0.056	1.486	0.008	0.068	0.879	0.811	0.837	0.791	0.00048	1.05477	0.01153	0.0252	

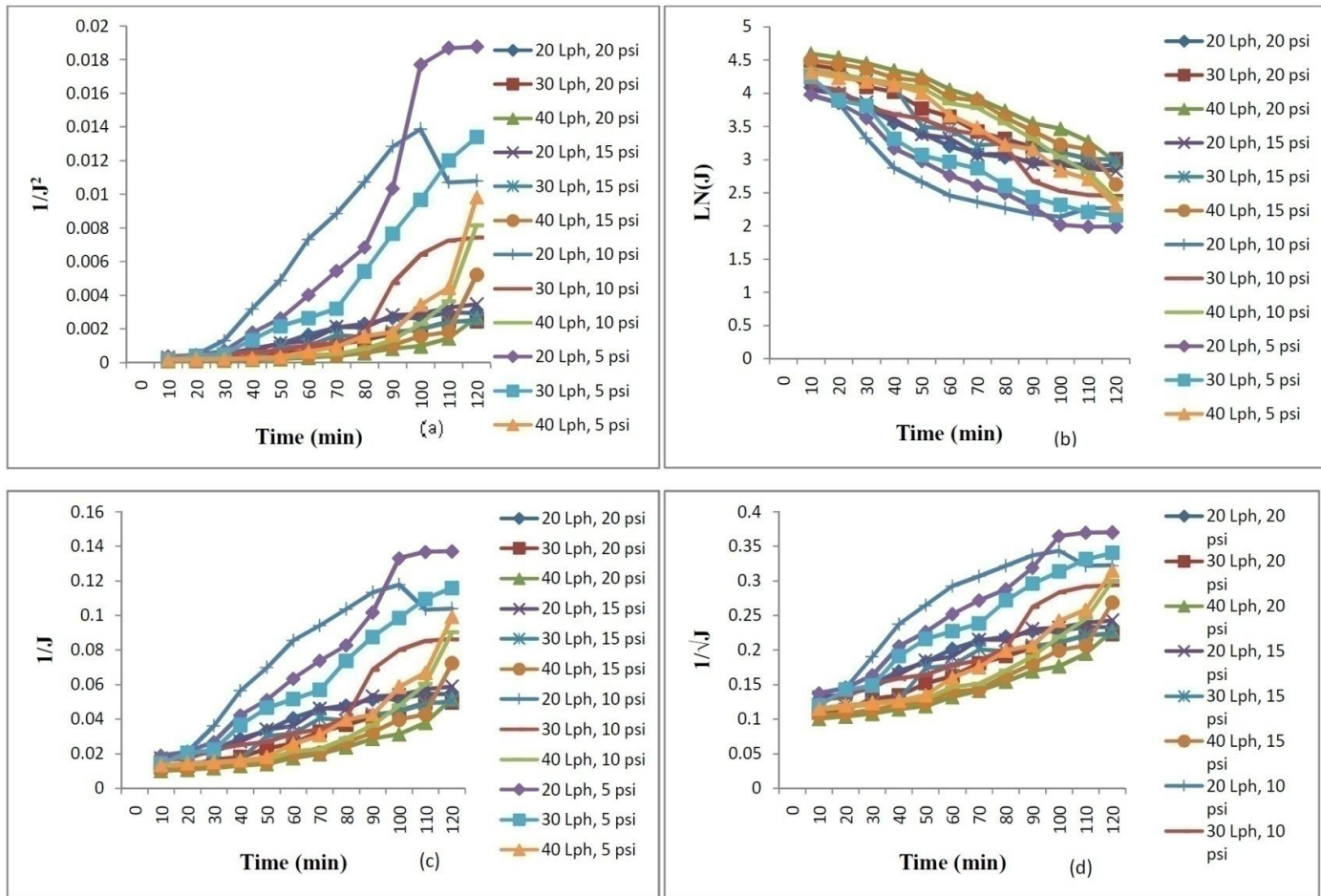

Fig. 6 Plots of characteristic parameters fit to various fouling models in UF of pomegranate juice through 70 kDa MWCO for membrane (a) gel layer formation, (b) complete pore blocking, (c) standard pore blocking, (d) intermediate pore blocking

(e) 44 kDa MWCO membrane

The membrane processing of pomegranate juice was performed using UF 44 kDa MWCO membrane and the data was tabulated (Fig. 7 and Table. 4).

The coefficient of determination (R^2) values for gel layer formation and Intermediate pore blocking were determined. The values of R^2 for gel layer formation were 0.844 to 0.993. The values of R^2 for IPB were in the range of 0.822 to 0.987. The standard error values for gel layer formation and IPB were low and high R^2 values were found. The other two models SPB and CPB gave poor fitting for the permeate flux data.

It was evident from the data that the fouling might have occurred because of IPB followed by gel layer formation. Pomegranate juice is a colloidal solution with its pulp and the material which could cause the fouling of pore walls and on the surface layer of membrane. Though different flow rates and TMPs were maintained, the high pressure forces the substances present on the secondary layer into the pores causing plugging of pores because of low MWCO of membrane (Blatt *et al.*, 1970).

(f) 10 kDa MWCO membrane

The membrane processing of pomegranate juice was also performed using UF 10 kDa MWCO membrane and the data was tabulated (Fig. 8 and Table 4). The coefficient of determination (R^2) values for gel layer formation and Intermediate pore blocking were determined. The values of R^2 for gel layer formation were 0.851 to 0.981. The values of R^2 for IPB were 0.804 to 0.966. The standard error values for gel layer formation and IPB were low and R^2 values were high. The other two models SPB and CPB gave poor fitting for the permeate flux data. Similar results were obtained as the previous study of membrane clarification with all other UF membranes.

The main reasons for the clogging of pores can be taken as the colloidal substances of the pomegranate juice for the occurrence of intermediate pore blocking followed by gel layer formation.

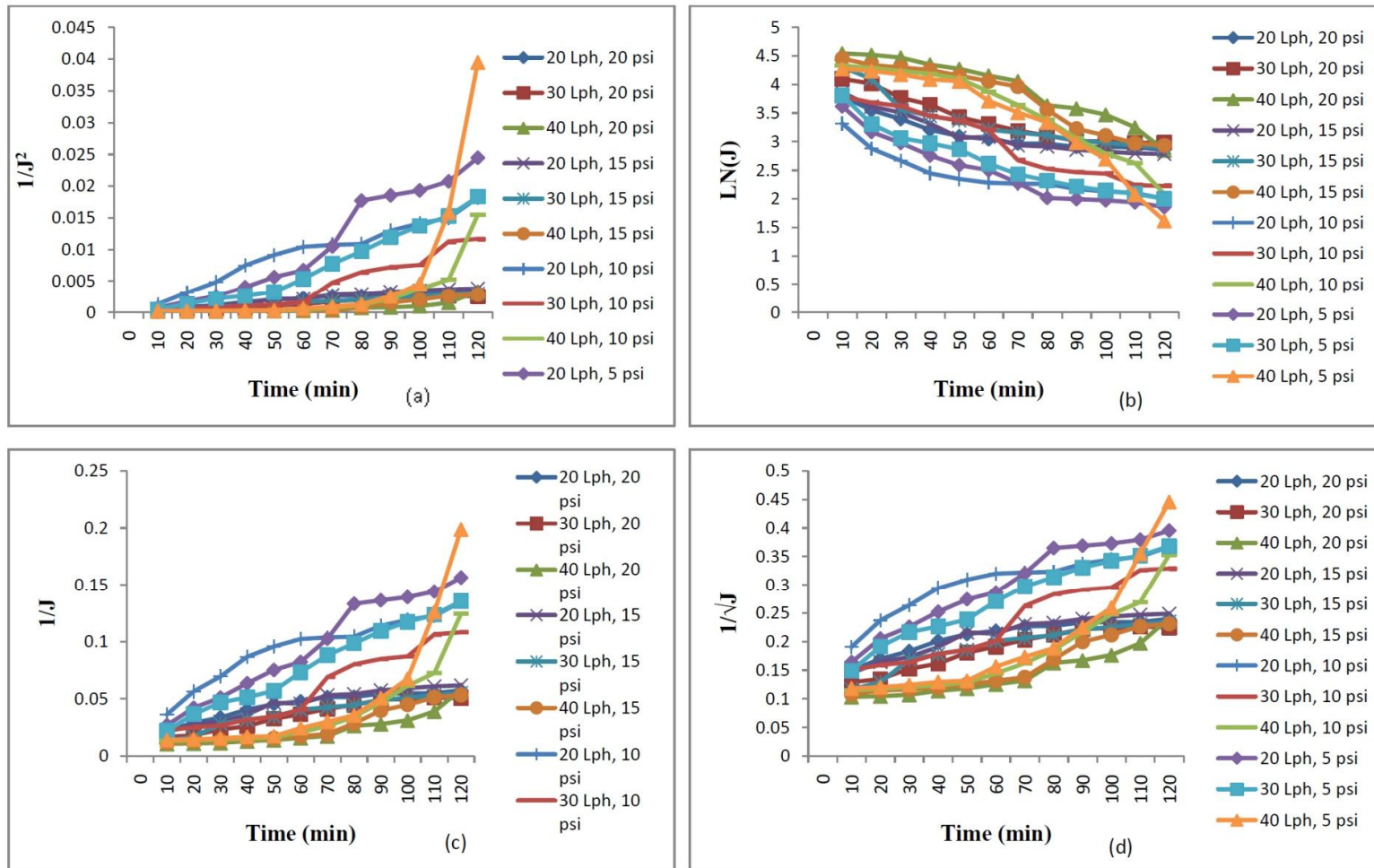

Fig. 7 Plots of characteristic parameters fit to various fouling models in UF of pomegranate juice through 44 kDa MWCO for membrane (a) gel layer formation, (b) complete pore blocking, (c) standard pore blocking, (d) intermediate pore blocking

Table 4. Statistical parameters for fitting of the fouling models to experimental data of UF of pomegranate juice

Membrane MWCO	TMP (psi) and Flow rate (Lph)	Sum of squares (SS)				R ²				Std Error			
		Gel	CPB	IPB	SPB	Gel	CPB	IPB	SPB	Gel	CPB	IPB	SPB
44 kDa	20 Lph, 20 psi	0.013	3.593	0.003	0.030	0.937	0.518	0.891	0.556	0.00095	1.29334	0.00649	0.04935
	30 Lph, 20 psi	0.011	1.199	0.003	0.035	0.969	0.703	0.925	0.718	0.00022	1.26533	0.00566	0.03326
	40 Lph, 20 psi	0.062	0.241	0.002	0.034	0.844	0.794	0.824	0.733	0.00601	0.90109	0.01755	0.03318
	20 Lph, 15 psi	0.021	1.579	0.004	0.038	0.983	0.745	0.879	0.651	0.00014	1.04209	0.00799	0.04012
	30 Lph, 15 psi	0.013	0.698	0.003	0.037	0.993	0.748	0.920	0.717	8.48E-05	0.96897	0.00637	0.03453
	40 Lph, 15 psi	0.099	0.010	0.003	0.041	0.874	0.708	0.890	0.850	0.00215	1.23787	0.00761	0.0237
	20 Lph, 10 psi	0.036	0.056	0.015	0.076	0.970	0.800	0.858	0.633	0.00017	0.79239	0.00856	0.04466
	30 Lph, 10 psi	0.019	1.557	0.014	0.091	0.875	0.769	0.949	0.847	0.00149	0.94179	0.00477	0.02436
	40 Lph, 10 psi	0.011	3.191	0.010	0.082	0.851	0.715	0.833	0.763	0.00485	1.0657	0.01439	0.03269
	20 Lph, 5 psi	0.087	2.543	0.030	0.128	0.939	0.607	0.971	0.540	0.00088	1.2672	0.00474	0.05922
	30 Lph, 5 psi	0.043	1.676	0.021	0.106	0.948	0.725	0.987	0.647	0.00027	1.05593	0.00441	0.04309
	40 Lph, 5 psi	0.064	0.941	0.025	0.131	0.863	0.782	0.822	0.715	0.00317	0.93791	0.03449	0.03969
10 kDa	20 Lph, 20 psi	0.011	0.770	0.002	0.022	0.853	0.070	0.809	0.694	0.00045	1.16867	0.01973	0.0428
	30 Lph, 20 psi	0.013	0.328	0.003	0.031	0.972	0.562	0.846	0.593	0.00012	1.11387	0.00948	0.05844
	40 Lph, 20 psi	0.015	0.005	0.004	0.045	0.759	0.709	0.906	0.743	0.00086	0.94025	0.0076	0.03363
	20 Lph, 15 psi	0.019	0.463	0.003	0.029	0.896	0.535	0.826	0.790	0.00043	1.14553	0.01306	0.02679
	30 Lph, 15 psi	0.015	0.329	0.003	0.031	0.904	0.552	0.903	0.570	0.00036	1.12597	0.00934	0.06766
	40 Lph, 15 psi	0.013	0.189	0.003	0.041	0.897	0.894	0.966	0.724	0.00039	0.75938	0.00319	0.04094
	20 Lph, 10 psi	0.061	0.002	0.020	0.087	0.915	0.809	0.804	0.600	0.00036	0.80067	0.01992	0.0527
	30 Lph, 10 psi	0.033	1.305	0.018	0.099	0.952	0.685	0.966	0.729	0.00025	0.95313	0.00511	0.04064
	40 Lph, 10 psi	0.052	0.492	0.007	0.064	0.851	0.699	0.959	0.781	0.00064	0.95273	0.00575	0.02681
	20 Lph, 5 psi	0.015	0.546	0.034	0.122	0.953	0.816	0.943	0.642	0.00018	0.79266	0.00733	0.04847
	30 Lph, 5 psi	0.069	0.154	0.023	0.099	0.981	0.785	0.956	0.642	0.00011	0.87054	0.00642	0.05036
	40 Lph, 5 psi	0.047	0.680	0.024	0.127	0.953	0.802	0.830	0.803	0.00022	0.84253	0.00997	0.0262

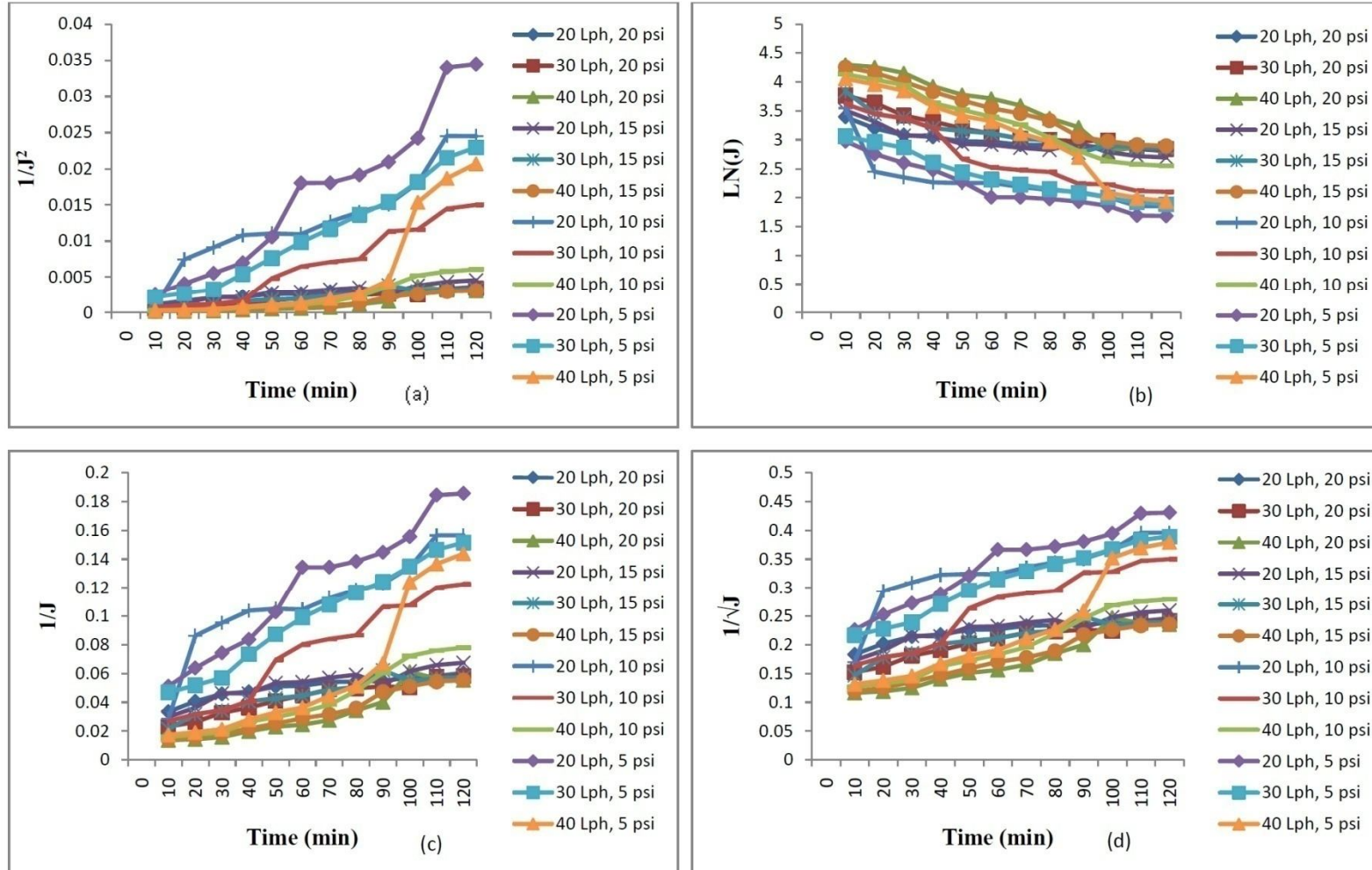

Fig. 8 Plots of characteristic parameters fit to various fouling models in UF of pomegranate juice through 10 kDa MWCO formembrane (a) gel layer formation, (b) complete pore blocking, (c) standard pore blocking, (d) intermediate pore blocking

Conclusions

Membrane processing of pomegranate juice was performed with different pore size membranes and the Coefficient of determination (R^2) values was analysed to validate fouling data using Hermia's analogy. The Coefficient of determination (R^2) values for gel layer model were in the range of 0.804 to 0.977 for 0.2 μm pore size membrane when pomegranate juice was filtered. R^2 values suggested intermediate pore blocking followed by gel layer formation.

References

- Aviram, M and Dornfeld, L. 2001. Pomegranate juice consumption inhibits serum angiotensin converting enzyme activity and reduces systolic blood pressure. *Atherosclerosis*. 158(1): 195-198.
- Blatt W F, Dravid A, Michaels A S and Nelsen L 1970. Solute Polarization and cake formation in membrane ultrafiltration: Causes, consequences, and control techniques. *Membrane Science and Technology*, Plenum Press, New York, p 47-97.
- Bowen, W.R and Jenner, F. 1995. Theoretical descriptions of membrane filtration of colloids and fine particles: an assessment and review. *Advances in Colloid and Interface Science*. 56:141-200.
- Domingues R C, Junior S B, Silva R B, Madrona G S, Cardoso V L and Reis M H 2011. Evaluation of enzymatic pretreatment of passion fruit juice. *Chemical Engineering Transactions* 24:517-522
- Grace, H.P. 1956. Structure and performance of filter media. I. The internal structure of filter media. *AIChE Journal*. 2:307-315.
- Hermia, J. 1982. Constant pressure blocking filtration laws: applications to power law non-Newtonian fluids. *Transactions of Institution of Chemical Engineers*. 60: 183-187.
- Oliveira, R.C.D, Doce, R.C. and de Barros, S.T.D. 2012. Clarification of passion fruit juice by micro filtration: Analyses of operating parameters, study of membrane fouling and juice quality. *Journal of Food Engineering*. 111(2):432-439.
- Razi, B., Aroujalian, A and Fathizadeh, M. 2012. Modeling of fouling layer deposition in cross-flow microfiltration during tomato juice clarification. *Food and Bioproducts Processing*. 90(4): 841-848.

Rai, C., Rai, P., Majumdar, G.C., De, S and Dasgupta, S. 2010. Mechanism of permeate flux declineduring microfiltration of watermelon (*Citrullus lanatus*) juice. *Food and Bioprocess Technology*. 3(4):545-553.

Shirato, M., Murase, T., Iritani, E and Nakatsuka. 1991. Experimental analysis of flux decline mechanism of batch ultrafiltration (filtration characteristics of gel layer). *Filtration and Seperation*. 28: 104-109.

Valero M, Vegara S, Martí N and Saura D 2014. Clarification of pomegranate juice at industrial scale. *Journal of Food Processing and Technology* 5(5):1-6

UNDER PEER REVIEW