

# **Challenges and Future Scope in Onion and Other Root Crop De-Topping Machines and Its Performance: A Review**

---

## **ABSTRACT**

Onion is one of the important vegetable and spice commodity crop which has yearlong demand but seasonal in production. Onion de-topping (i.e., separation of matured leaves from bulbs) is the important post-harvest operation in onion production which conducted after curing process of onion bulbs. In India onion de-topping done mostly manually in farms using sickle, khurpi and knife. Manually onion de-topping of onion bulbs is time consuming and labour-intensive operation. Availability of labours are difficult in peak harvesting season of onion; therefore, farmers may incur financial and crop loss. Mechanical onion de-topping done using onion harvesters during digging operation of onion bulbs. There are many onion de-topping machines are available for onion bulbs with different mechanism. The different onion de-topping machine were studied in terms of their mechanism, construction, working principles, performance and efficiency. The comparison of performance of the machines with manual onion de-topping was studied over the cutting capacity, efficiency, damage percentage, saving of labour cost and time. This paper reviews such onion de-topping harvesters and de-topping machines. It highlights the mechanism used for de-topping in these machines with their performance in terms of de-topping capacity and de-topping efficiency. It also tries to highlight the necessity of requirement of de-topping machines and current status of adoption of such machines by farmers in India. It was observed that number of onion de-topping machines are available though it is difficult to adopt by the farmers specially medium and low land holding farmers because of cost concern. Therefore, it is necessary to develop the machine which should be low cost, efficient and labour saving for such farmers. Using such an onion de-topping machines will help to save their labour cost, operational time, drudgery of labour and increase efficiency of labour. Also adopting such technologies can encourage the farmers to increase the production of such crop.

*Keywords: onion de-topping, leaves cutting, manual de-topping, de-topping machines, de-topping efficiency*

## **1. INTRODUCTION**

Onions are the important spice commodities consumed in India almost every day in every house (Ahmed et al., 2022). Indian onions are famous for their pungency and are available round the year. It is the important vegetable crop, grown almost all over the country, which is seasonal in production, but required round the year (Dabhi and Patel, 2017). Physiological construction of an onion bulb is a swelling in the leaves just above the point of attachment of stem to roots. The part of leaves protruding from onion bulbs is referred as tops, the surface at which those tops leave the onion bulb is referred to as crown, and tops immediately above crown are referred to as neck. The onion is grown both in kharif and rabi seasons. Bulbs are considered mature when the neck tissues begin to soften, and tops are about to abscise and decolorize. Onion for sale as dried bulbs or for storage should be harvested after the tops have started falling over. Best time to harvest rabi onion is one week after 50 per cent tops

have fallen over. In kharif season since tops do not fall, soon after the colour of leaves change to slightly yellow and tops start drying, red pigmentation on bulbs develops also true shape and size develop, bulbs are harvested (Rani and Srivastava, 2006).

The world acreage of onion has doubled during the last one decade. In 2020, world production of onions and shallots was 4.5 million tonnes, led by the Republic of China with 20% of the world total. India ranks second in onion production in the world, which acquires 6% of the market share in the total production of vegetables in India (Ahmed et al., 2022). According to estimate of the Agriculture Ministry, the area sown for onion cultivation is estimated to be 1.62 million hectares in 2021-22. The country had harvested 26.64 million ton of onion in 2021-22 crop year (Anonymous, 2022). Major onion producing states area Maharashtra, Karnataka, Madhya Pradesh, Gujarat, Bihar, Andhra Pradesh, Rajasthan, Haryana, and Telangana. Maharashtra ranks first in Onion production with a share of 28.32% (APEDA, 2022). Compare to world's average the yield of onion in India is lesser because one of the reasons is using traditional harvesting practices by manual labour which cause wastage of produce (Kumawat and Raheman, 2022).

Indian onions have two crop cycles, first harvesting starts in November to January and the second harvesting from January to May. The major varieties found in India are Agrifound Dark Red, Agrifound Light Red, NHRDF Red, Agrifound White, Agrifound Rose and Agrifound Red, PusaRatnar, Pusa Red, Pusa White Round. There are certain varieties in yellow onion which are suitable for export in European countries Tana F1, Arad-H, Suprex, Granex 55, HA 60 and Granex 429 (APEDA, 2022).

The onion harvesting operation includes digging, lifting, field curing for 3-5 days, cutting the necks to separate onions from the foliage, cleaning and grading of bulbs, shed curing and storage. Presently onion de-topping is done by manually which is time consuming and labor-intensive operation, whereas in the western countries, onion combine harvesters are used for onion harvesting. But such combine harvesters are not suitable for Indian agriculture because of small and medium land holdings of farmers. These harvesters require higher initial investments which is a major constrain in its adoption (More et al., 2018). The harvesting of onion crop is laborious work and requires huge amount of manpower and time. As a part of harvesting of onion, root and shoot has to be trimmed manually, this is a labour-oriented process. One of the main reasons of low productivity is low level of mechanization and less technology utilization. Imported machines are expensive and an Indian farmer cannot afford such high price. Farmers incur financial loss because of non-availability of manpower (Chaudhary et al., 2016).

Therefore, a study was undertaken to review onion bulbs and other root crop de-topping methods and available machines with their performance.

## **2. ONION DE-TOPPING METHODS**

Onion de-topping methods can categorized in to two types i.e., manual onion de-topping and mechanical onion de-topping.

### **2.1 Manual Onion De-topping**

In manual type of onion harvesting onion bulbs are dug out manually using khurpi from the field along with leaves and after sun curing of 2 to 3 days leaves are cut at neck length of 20 mm from onion bulbs (Anonymous, 2019). De-topping of onion leaves done manually using sickle, khurpi or knife as shown in Fig. 1 (Kumawat and Raheman, 2022).

Harvesting of one-hectare small onion crop required 15-woman days and de-topping of onion leaves done by manually required 12.5 man-h for 1 MT onion bulbs (Nisha and Shridar, 2018). Omar et al., (2018) reported that before digging onion de-topping done by hand when the onion bulbs in field. In peak time of onion harvesting season, there is high demand for labour which is difficult fulfil by the farmers. In India existing method of manual onion de-topping is labour sitting in position to cut leaves from onion bulbs with help of sickle or khurpi (Parab et al., 2019).



**Fig. 1: Manually onion de-topping of cured onion bulbs (Chittappa, 2016)**

Chauhan et al., (1995) reported that lowest total storage losses i.e., 19.43 % were observed with windrow method followed by 10 days in shade curing with tops and cutting the neck to 25 mm as compared to other treatments. Field curing by windrow method for three to five days and shade curing with tops for 10 to 12 days and 25 mm neck length observed more effective in reducing storage losses in onion (Singhal, 2000). Curing for five days is done by placing several rows together into windrows with the green tops covering the bulbs to prevent sunburn. Onion de-topping is done with sickle keeping 4 cm onion neck length from bulb. Curing de-topped onion in shade for three weeks making thin heap (Anonymous<sup>a</sup>, 2011). Onions are harvested when 50 % - 75 % of tops fall in field. The leaves generally cut leaving about 2 to 2.5 cm tops above the bulb after complete drying. If tops cut too close to the bulb, then the neck does not close well, and organisms can easy access to the bulb causing decay (Anonymous<sup>b</sup>, 2011). Curing of harvested onion bulbs is completed when the neck is completely dry and tight. If the neck remained open, incidence of pathogens such as Botrytis neck rot observed. About 2 to 3 inches of neck should be kept on the bulb. This increased the distance from the cut surface to the bulb for these pathogens to travel. Mechanical injury during harvest & topping need to be minimized. Drops should be reduced to 6 inches and pad sharp surfaces (Howell et.al, 2011).

Ambrose and Annamalai (2013) develop manually operated root crop washer for root vegetables like carrot, radish etc. The washer consists of a de-topper, a stainless-steel washing drum, center shaft with holes for water spraying etc. The de-topping unit is mounted at 30 cm distance from the drum. A platform of size 24 × 24 cm is provided for keeping the vegetables. De-topping is carried with the aid of a knife fitted along the side of the loading platform.

## **2.2 Mechanical Onion De-topping**

Mechanical onion de-topping done using the mechanical harvesters and onion de-topping machines. Williams and Franklin (1971) reported that production cost of onion can be reduced by 20% per hundred weight of onion bulbs for harvesting and storing by mechanical harvesters.

### **2.2.1 Onion harvesters with de-topping mechanism**

Mechanical onion harvesters dig onion bulbs and cut leaves which results in 5-to-6-time higher productivity as compared to manual methods (Abenavoli et al., 2004). Lorenzen (1949) developed a mechanical onion harvester which consists of picking mechanism, digging unit, topping unit, and top disposal belts. The de-topping mechanism consisted of two 6-inch diameter, overlapping discs, and 1/8 inch thick. These were bevelled to sharp edges on opposite faces and mounted directly above the pickup belts. The discs were driven at a peripheral speed 2.5 times the speed of the pickup belts. The cutting action is conducted using a slicing action.

Hiroshi (1953) developed an onion harvester which consists of two finger type mechanisms which hold and lift onion bulbs along with leaves. This harvester digs out onion bulbs and cuts onion leaves with a pair of cutting discs.

Lauridsen (1968) developed a machine for harvesting onion crops in which the de-topping unit consists of a counter-rotating pair of spiral rolls. Spiral rolls receive onion from the front conveyor and move onion to the de-topping mechanism. A paddle wheel with a flexible blade under the alignment of rolls turns the onion bulb tops towards the cutter and a flexible skirt provided to wipe the de-topped leaves of the onion bulbs.

Frank et al. (1969) invented an onion harvesting machine which consisted of a finishing table, formed as a series of spiralled rolls, shifted the onions falling from the conveyor across the table with the tops being pulled downward between rolls. The cutter at the end of the spiral rolls cuts the tops from the onions and drops them onto the cutter. The spiral rolls of the finishing table were made of resilient material to prevent damage to the onions.

Lepori and Hobgood (1970) studied three types of onion harvesters. These harvesters consist of a rod type chain conveyor for lifting onion bulbs using different onion de-topping methods. In the first method, initially onion bulbs are lifted, and de-topping is done using an air blast below the rod chain conveyor. In the second method, de-topping is done using rotating pairs of rollers which rotate in opposite directions of each other, fixed at the end of the conveyor. Due to the rotation of rollers, onion leaves are pulled off from bulbs. In the third method, onion bulbs are dug and lifted using a blade. Bulbs are elevated at a 30° angle from the ground surface and a rotary cutter which consists of a serrated knife of speed 18 m/s cuts leaves from onion bulbs.

Medlock et al., (1976) developed an onion harvester which consists of a grasping mechanism that holds onion bulbs with leaves and cuts leaves from bulbs by counter-rotating rollers. By windrowing the onion bulbs, it transfers bulbs into a collection bin.

Droll et al., (1976) developed a rotary type onion de-topper for removal of onion leaves before digging of bulbs. It is suggested that de-topping of onion bulbs should be done before digging from the soil. Rotary type de-topper consists of two blades of 762 mm diameter which rotate at a speed of 2000 rpm.

Wingate-Hill (1977) developed a single row top lifting harvester which uproots the onion bulbs from the soil and transfers onion bulbs to a de-topping mechanism with the help of rotating lifting

belts. Cutting blade of diameter 250 mm used which rotate at speed of 2800 rpm. Cutting blade positioned in such manner that it maintains the neck length of 20 mm from onion bulbs. After de-topping onion bulbs convey into temporary storage bin. Damage percentage of onion bulbs was observed decreased for bulb size greater than 76 mm and increased for onion bulb size less than 37 mm.

Chesson et al., (1978) developed onion field digger with de-topper for harvesting onion bulbs. It de-top onion bulbs while bulbs in soil by maintaining neck height 38 to 51 mm. A rotary cutter of diameter 760 mm was used which rotate at speed of 1800 to 3000 rpm and an airflow used to lift the cut leaves. In single pass an average 81 % leaves cut satisfactorily using this de-topper mechanism.

Maw et al., (1998) developed a self-propelled single row onion harvester which lift onion bulbs from field and de-top. A circular saw blade of diameter 254 mm made of tungsten carbide used to cut onion bulb leaves which rotates at speed of 1750 rpm. Power to the blade given by 0.25 kW AC electric motor. It is observed that 21 % neck length of harvested onion bulbs found to be in desirable limit having length of 40 to 60 mm.

Bendix and Krier (2002) developed mechanical harvester for digging and de-topping of onion bulbs. It is dugout onion bulbs and convey to cutting unit using conveyor. Pair of cutting disc used to cut onion leaves and onion bulbs dropped in field after cutting operation.

Kido and Shuff (2006) developed onion harvester with toppler which pull onion bulbs in an inverted position from field by pair of rotating rollers. Onion bulbs moved to counter rotating rollers which consist of elastomeric fingers which pulled onion leaves downward.

Ye (2017) developed beet tops harvesting machine as shown in Fig 2. Theoretical research of technological process sugar beet tops cutting by the rotor mechanism are conducted. Arc-shaped blade of knife which pivotally mounted on a power horizontal shaft is constructed for beet top bunch cutting. Developed an ultra-light, highly reliable rotary-type beet tops harvesting unit design is frontally mounted on wheeled tractor.

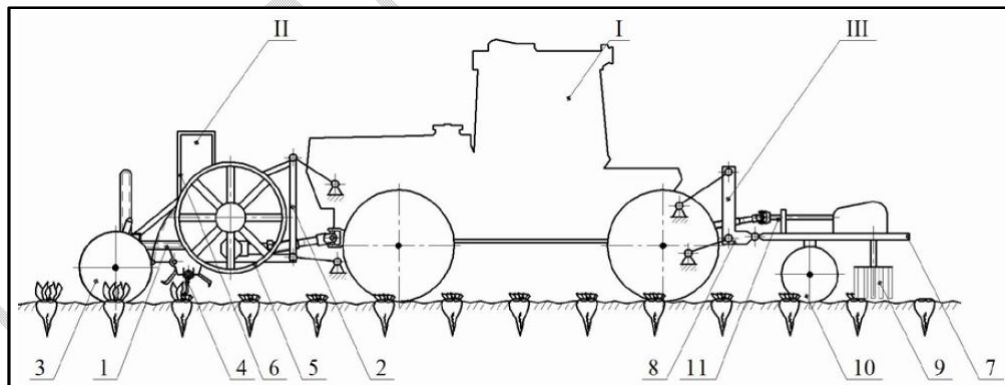

I – tractor; II – front-mounted beet tops harvesting machine: 1 – frame; 2 – hinged device; 3 – pneumatic support wheels; 4 – rotary beet tops cutting apparatus; 5 – screw conveyor and vane conveyor; 6 – loading tube; III – root crops heads cleaner from tops remains: 7 – frame; 8 – hinged device; 9 – cleaning shaft; 10 – support wheel; 11 – drive unit

**Fig. 2: Schematic diagram of beet tops harvesting machine (Ye, 2017)**

Rani et al. (2018) design and develop a tractor operated carrot digger. The carrot digger consisted of digging unit, conveying unit, de-topping unit, collecting unit, main frame, and power transmission system. De-topping unit was provided to cut the leaves of carrots by the

two serrated discs rotating in opposite direction, provided below the conveying unit as shown in Fig. 3. Serrations were provided on the discs in order to avoid slippage of the leaves of carrot. The spacing between the serration of disc was kept less than the diameter of the carrot leaves at top of the carrot. These two cutting discs overlapped at cutting edge. Each disc was bolted below a sprocket which took drive from the conveying chain.

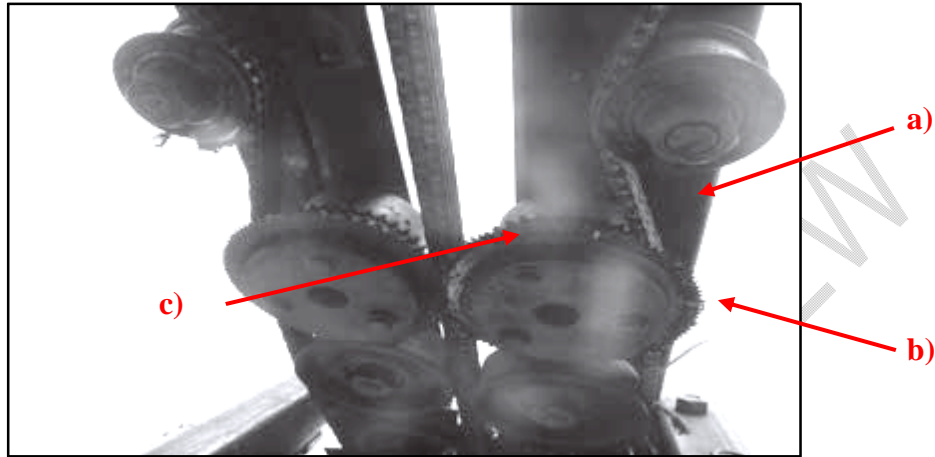

a) Triple pitch roller chain, b) Cutting discs, c) Sprocket

**Fig 3: De-topping unit of the developed carrot digger (Rani et al., 2018)**

Mozaffary et al. (2004) design and developed onion harvester for small farms. Mechanism consists of rotary blade for de-topping onion bulbs which rotate at speed of 1500 – 2000 rpm. The parameter studied like acceptable top percentage, not acceptable top percentage, not topped percentage and damaged bulb percentage. The mechanism observed most suitable for onion de-topping with acceptable top 87.7 % at 2000 rpm and 83.9 % at 1500 rpm.

Nour et al. (2020) develop and evaluated performance of local harvesting machine for onion crop. The machine was consisted mainly of digging and dislocation unit, separating unit, cleaning unit, conveying unit, transmission system, main frame, and land wheels as shown in Fig. 4. Separating unit consists of two serrated cutting discs with 18 cm diameter and clearance between discs 4.76 mm, to achieve the stripping operation of bulbs without any damage, where the crown zone enters discs which move in the opposite direction of plant movement in order to work on separation of the bulbs from the plant. The cutting discs are operated by the main chain's shaft through pulleys and belts.



**Fig. 4: Developed harvesting machine for onion crop (Nour et al., 2020)**

Kumawat and Raheman, (2022) designed de-topper cum digger for a power tiller for onion crop for marginal farmers in India as shown in Fig 5. The designed harvester suitable for de-topping onion top in field and digging of de-topped onion bulbs with separation mechanism for soil and other unwanted materials from de-topped onion bulbs. A rotary de-topper provided at front of the power tiller and provision made for height of cutting and digging. It could be ideal design for de-topping and harvesting of onion bulbs in simultaneous operation.

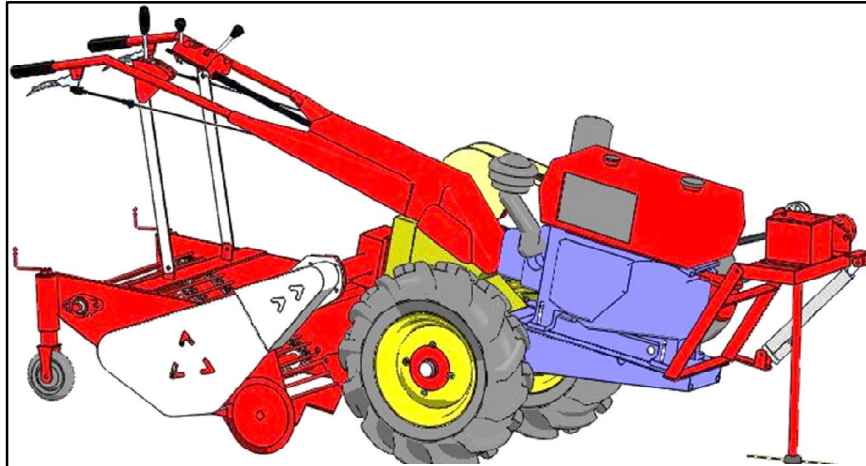

**Fig. 5: Designed de-topper cum digger for a power tiller for onion crop (Kumawat and Raheman, 2022)**

### **2.2.2 Onion de-topping machines**

Many researchers developed onion de-topping machine in which some are specially only for onion de-topping, and some are combine with grading and other operation machines.

Carson and Williams (1969) designed and field-tested onion de-topper and conducted an experiment. Machine works for six-row at a time with two tined wheel per row to lift lodged tops. Six 18-inch diameter rotary blades were used to remove the tops. De-topping quality of machine compared with manual method of de-topping using long sharp knife for de-topping, and it was found that top removed 82.2 and 100 % and damage was observed 2.4 and 0.0 %, respectively.

Mayhoub et al., (2009) design mechanism for green onion crop handling. Handling system consists of feeding unit, trimming unit which based on rotary cutting mechanism as shown in Fig. 6. The feeding unit consists of a flax belt of 4 mm thickness, 100 cm length and 25 cm width. The feeding belt driven with two drums having a diameter of 6 cm and length of 34 cm and rotating through four bearings bolted in the frame. A V-belt and three pulleys used to transmit the motion from an electric motor (0.2 kW) to the driver drum. The motor provided with electric resistor to give revolution speeds of 20 and 80 rpm. The trimming unit consists of two cutting discs made from steel-plate having a 15 cm diameter fixed on two axes with 20 mm diameter and 40 cm long rotating through four bearings bolted in the frame. The performance evaluated in terms of machine productivity, trimming efficiency, cutting offset angle of plants, the quality of the final product and the costs of green onion produced by mechanism system. Results indicated that the machine productivity was found to be 316.2 kg/h, handling system efficiency was 75.89 %, the trimming efficiency was 89.15 %, cutting offset angle of plants was 22°, at 12.5 cm/s feeding-belt speed and when 5.6 kg/min feeding rate. With operated at 5.11 m/s cutting disc speed, the optimum tying position during

trimming process is 7.5 cm, the wilting coefficient was (0.09 mm/day) at discharge rate of 5 l/h and handling machine reduced the cost of green onion trimming to 1: 2.67 as compared with manual method.



**Fig. 6: Trimming unit of green onion crop handling mechanism (Mayhoub et al., 2009)**

Rani and Srivastava (2012) designed and developed onion de-topper which consisted of a chute type feeding unit, a belt conveyor, an oscillating conveyor, rotating fingers, and a rotating cutter. All components mounted on a main frame. An electric powered transmission system used to drive all moving components. Onion bulbs fed through a chute type feeding unit which convey onion bulbs to belt conveyor and transport uniformly on oscillating conveyor. Belt conveyor had two rollers and an endless conveyor belt moving at a speed of 0.53 m/s. The oscillating conveyor facilitate downward orientation of onion leaves. Provision to vary the oscillator slope and speed was also provided. Downward oriented onion bulbs with leaves passed through rotating cutters which provided at downward side of oscillating conveyor so that cutting could be done from beneath without damaging the bulbs. Output capacity of onion de-topper observed 300 kg/h with de-topping efficiency of 79 %.

Bhanage (2012) developed power-operated onion de-topper. Machine consists of main frame, conveying unit, cutting unit, safety guard and power transmission unit as shown in Fig. 7. Conveying unit consist of two spiral rollers which made of M.S. seamless tube having 50 mm pitch and 4 mm depth. Cutting unit consists of a shaft, two plain and one serrated cutter. Separate electric motors were provided for power transmission to reduce turgidity of gear box. Cutting height adjusted using allen screw fitted on cutter shaft. Average de-topping efficiency observed 86.10 % with output capacity of 305.68 kg/h. Power requirement of machine was found to be 0.5 kw/h and average time required for de-topping was 0.327 h/q. Onion neck length maintained by machine during operation was found to be 21.09 mm which is sufficient for reducing storage losses of onions. Cost of operation required for machine was Rs.17.37 per quintal with average net saving Rs.7.63 per quintal by using this machine over traditional method.

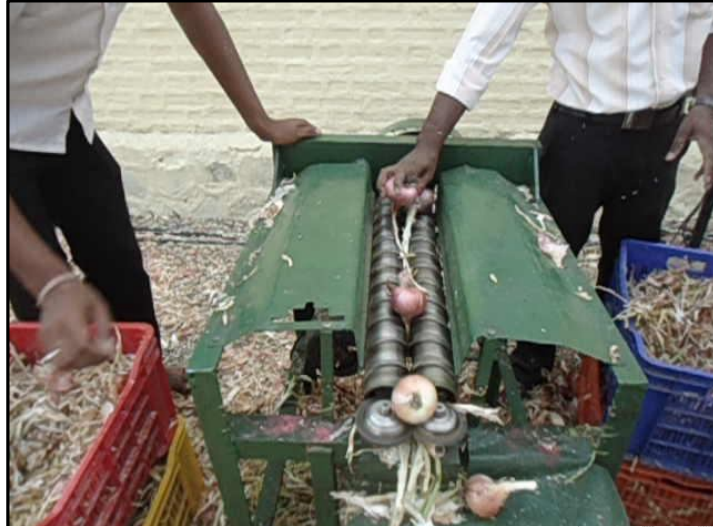

**Fig. 7: Power-operated onion de-topper in operation (Bhanage, 2012)**

Londhe et al. (2014) developed power operated onion de-topper- cum-grader and evaluated performance which consisted of main frame, conveying unit, safety guard and power transmission unit. Electric motors were used as prime movers for conveying and cutting mechanism. Onions after de-topping graded in five grades i.e., <35 mm, 35-50 mm, 50-60 mm, 60-85 mm and >85 mm. Field performance of machine observed that average de-topping efficiency was 85.71 % with output capacity of 237.192 kg/h. Average feeding rate found to be 276.856 kg/h and average time required for de-topping was 0.421 hour per quintal. Average power requirement for machine during operation found to be 0.880 kW/h. Before and after de-topping average onion neck length observed 314.8 mm and 23.433 mm, respectively. Over manually de-topping and grading operation net saving observed Rs.55.67 per quintal by using this machine and simultaneously automatic de-topping and grading can be done.

Barman et al. (2015) developed and evaluated performance of power operated garlic stem and root cutter. Machine consists of main frame, feeding unit with two feeder boxes, clamping unit, cutting unit, power transmission unit and garlic bulb dropping chute as shown in Fig.8. Counter rotating cutting discs are used to cutting operation and pair of spur gear was used for transmission of power. Two feeder boxes provided on both side of the machine. Garlic with leaves fed manually one by one inside the feeder box by putting the stem towards outside of the machine. The bulb and stem are hold between the clamping devices. Due to counter rotating motion of cutting discs, the stem and root pulled towards inside the cutter and cut by shearing force. 10 mm overlapping of cutting discs provided for easy removal of stem and roots. After cutting of stem and root garlic bulb falls in chute provided below cutting mechanism and collected in collecting tray. Average output capacity for one side feeder box found to be 32.52 kg/h with cutting efficiency of 99.08 %. Length of cut stem and length of cut root were 23.25 mm and 2.28 mm respectively. Power requirement and cost of operation for machine found to be 1.2 kWh and Rs 48.5 per hour, respectively.

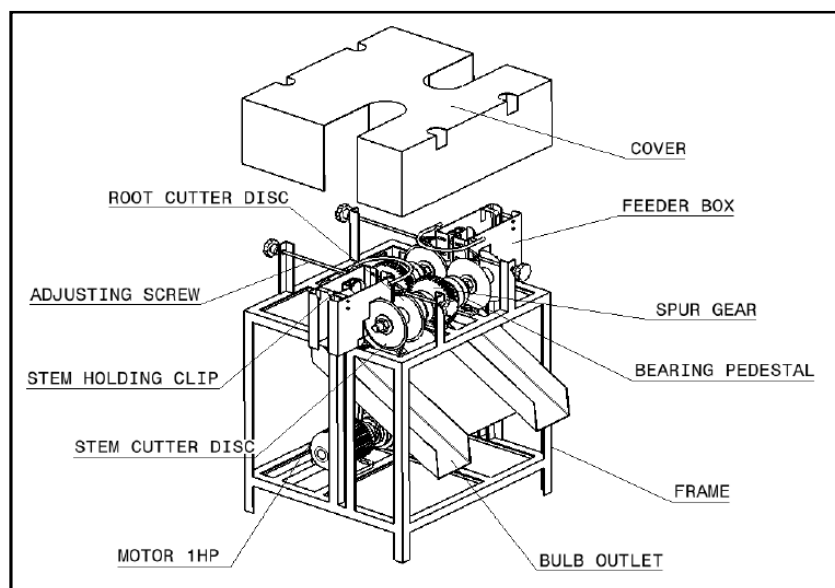

**Fig. 8: Isometric view of garlic stem and root cutter (Barman et al., 2015)**

Chaudhary et al. (2016) design machine for onion root and shoot cutting. The machine consists of parts like sprocket chain drive, holding devices, guideways, disk type shoot cutter, motor, chain tightening mechanism. Root cutter is mounted at bottom which cuts down root part of onion. Onion is first fed to the holding device which has single leaf spring to hold different size of onions. The conveyor belt will move the onion forward at specific speed. Guide ways and conveyor will support onion from bottom and top so that it will not fall on side way. A cutter provided mid-way on conveyor will cut root from bottom. The onion continues its motion and is guided into toppling mechanism which inverts onion by 180 degree and move forward up to next cutter provided to cut shoot parts. The shoot will be collected in a hopper and onion in another hopper.

Chittappa (2016) design and developed motorized onion de-topper cum grader. De-topping unit consists of set of de-topping rollers, main frame and power transmission system as shown in Fig. 9. De-topping unit consist of set of rollers comprising alternate arrangement of roller having cutting edge along its length and plain roller. Four set of rollers mounted on a main frame with clearance of 2 mm provided between rollers. Plain and cutting rollers rotates counter direction of each other. Onion tops drawn in between rollers and made an orientation of tops in downward position and sharp edges of shearing rollers further de-tops onion tops. Plurality of rollers ensured higher percentage of de-topping of onion tops before onion bulbs reaches to collection tray. De-topped onion tops collected in collection tray provided below the onion de-topping unit. De-topping efficiency of machine found to be 90.58 % with effectiveness of de-topping 0.92. Damage percentage of onion bulbs observed 8.68 % and non-de-topped onion observed 2.50 %. Capacity of onion de-topping machine found to be 371.20 kg/h with 37 % saving cost against conventional de-topping method.



**Fig. 9: Power operated onion de-topper (Chittappa, 2016)**

Kale et al. (2018) designed onion leaf cutting machine. Leaf cutting machine works on conveyer belt and cutter arrangement. This design consists of cutter & belt conveyer assembly which is mounted on end side of movable platform on M.S. frame. The rotary cutters are mounted at the top side of the belt conveyer system. At time of operation the onion leaf cutter/remover, onion can push on conveyer which move in forward direction. When there is approach of onion to cutter due electric cutter it cut the leaf of onion. Belt conveyer system supported by support of four pedestal bearing operated by using electric gear motor. After cutting of onion and leaf are separated and collected in tray.

More et al. (2018) developed power operated de-topper and grading machine for harvested onion crop which consist of feeding mechanism, de-topping mechanism and grading mechanism. De-topping mechanism consist of main frame, conveying unit, cutting unit, safety guard and power transmission unit. Cutting unit consist of shaft, two plain and one serrated cutter. Onion bulb with leaves fed manually to feeding hopper. Inclined flat belt conveys onion toward the onion de-topping mechanism. Both spiral rollers pull tops into an inverted position with leafy portion in downward direction and assist in advancement of onion bulb along the length of spiral rollers to deliver the onions to cutting mechanism. Cutting mechanism pick up conveyed onions from spiral rollers and cut top of onion. Onion top cut due to counter rotating cutters. After de-topping, onion bulbs fall down into divergent grading rollers. Average de-topping efficiency was 85.71% with 237.19 kg/h output capacity. Average feeding rate was found to be 276.86 kg/h and average time required for de-topping 0.42 h/q. Average power requirement at load was found to be 0.88 Kw/h. Average output capacity of manual onion de-topping and grading were 30 kg/h and 100 kg/h respectively. Average cost of operation for power operated onion de-topper-cum-grader was Rs 34.27 per quintal. Average cost of operation of manual onion de-topping and grading was Rs 81.25 per quintal. Net saving by using power operated onion de-topper-cum-grader over manually de-topping and grading was Rs 46.98 per quintal.

Anand et al. (2020) designed and fabricated stem cutting machine for shallot onion owing to the practical problem in the processing of shallot onion. Before using for experiments samples kept under shade condition and experiments conducted on fabricated machine with different parameters like slope of machine and different speeds of rollers with a constant

weight of sample at 10 kg. The slope angle was taken at 10°, 20°, and 30°. Speed of the rollers set from 500 to 1500 rpm with an increment of 100 rpm. Cutting efficiency of machine observed very good i.e., 100% with less damage to bulbs i.e., 2%. Better results observed at speed of rollers showed at 1000 rpm in all inclinations with inclination of 20°.

#### 4. CONCLUSION

Study of various literatures available on manual and mechanical onion bulbs de-topping was carried out. Conclusions made on available literatures are as follows:

1. In Manual harvesting of onion bulbs de-topping of onion leaves done manually by labour using sickle, khurpi or knife after sun curing of 2 to 3 days.
2. Manual de-topping of onion bulbs is time consuming and require large number of labours which are unavailable during the peak harvesting season of onion bulbs.
3. Continuous sitting position to cut leaves by sickle or khurpi cause drudgery to labour by reducing their working efficiency.
4. Mechanically de-topping done using along with harvesters when onion bulbs in soil and using special onion de-topping machines after pulling onion bulbs from soil.
5. Many types of mechanisms available for de-topping of onion bulbs along with harvesters but these mechanisms are much complicated and difficult to adopt in small land farms.
6. Many researchers developed onion de-topping machines with various de-topping mechanisms and this mechanism found to be effective for onion de-topping in bunk quantity. Among various mechanism the rollers de-topping based mechanism found to be much effective for onion de-topping.

Though many de-topping machines along with harvesters are available in India, but adoption of these mechanisms for farmers in farms are difficult due high cost of machines and complication in mechanism. Therefore, onion de-topping still done in farm by manually using traditional method. Hence it is necessary to develop a simple, with low cost and efficient de-topping mechanism for onion bulbs.

#### Disclaimer (Artificial intelligence)

##### Option 1:

Author(s) hereby declare that NO generative AI technologies such as Large Language Models (ChatGPT, COPILOT, etc.) and text-to-image generators have been used during the writing or editing of this manuscript.

##### Option 2:

Author(s) hereby declare that generative AI technologies such as Large Language Models, etc. have been used during the writing or editing of manuscripts. This explanation will include the name, version, model, and source of the generative AI technology and as well as all input prompts provided to the generative AI technology

Details of the AI usage are given below:

##### 1.

2.

3.

## REFERENCES

Abenavoli D L M, F Giametta and S Morabito.2004. Onion: harvesting and post-harvesting mechanized operations. In: 2004 CIGR International Conference Beijing Sponsored by CIGR, CSAM and CSAE Beijing, China, pp. 11–14

Ahmed S M, V Reddy, R Chandrahas, and V K Gunjan. 2022. Effective Monitoring of Onion Production Stored in Warehouse to Reduce the Commercial Commodity Wastage and Improve Reutilization. In Modern Approaches in Machine Learning & Cognitive Science: A Walkthrough, pp. 343 – 352, Springer, Cham.

Ambrose D C, and S J K Annamalai.2013. Development of a manually operated root crop washer. African Journal of Agricultural Research, 8(24): 3097 – 3101.

Anand M T, N Venkatachalapathy, S Anandakumar, and A Pare.2020. Effect of roller speed and inclination angle on the stem cutting efficiency of shallot onion. Current Journal of Applied Science and Technology, 39(19): 177 – 183.

Anonymous (a). 2011. Onion growing technology, Krishidharshani, Mahatma PhuleKrishiVidyapeeth, Rahuri, Maharashtra. PP 118.

Anonymous (b). 2011. AICRP on FIM, MPKV, Rahuri, Annual Report, PP 40 – 45.

Anonymous. 2019. National horticultural board, ministry of agriculture, government of India, New Delhi, India. (2019b).  
<http://nhb.gov.in/PDFViwer.aspx?enc=3ZOO8K5CzcdC/Yq6HcdIxMfvLt8gOzIYTCIRQLD?jKU>

APEDA. 2022. A report by Agricultural & Processed Food Products Export Development Authority. Ministry of Commerce and Industry, Gov. of India.

Barman C, Y C Bhatt, H K Jain, and S S Vyas. 2015. Performance Evaluation of Power Operated Garlic Stem and Root cutter. Agricultural Engineering Today, 39(3): 57 – 61.

Bendix R D and O D Krier. 2002. U.S. Patent No. 6,484,810. Washington, DC: U.S. Patent and Trademark Office.

Bhanage G B. 2012. Development and performance evaluation of power operated onion de-topper. Unpublished M. Tech. thesis M. P. K. V. Rahuri.

Chaudhary V R, P Vania, C Khilan, N Bulsara, and M Bulsara. 2016. Design of onion root and shoot cutting machine. History. 2(7): 345 – 351.

Chaudhary, V R, P Vania, C Khilan, N Bulsara and M Bulsara. 2016. Design of onion root and shoot cutting machine. History. 2(7): 345 – 351.

Chauhan K P S, S P Singh, and A B Chougule.1995. Studies on the effect of windrow curing, neck cut and shade curing on export quality of onion bulbs during storage. National Horticultural Research and Development Foundation Newsletter, 15(4): 5-7.

Chesson J H, H Johnson, C R Brooks, R G Curley, P F Burkner, R M Perkins.1978. Mechanical harvesting investigations for fresh market onions. Trans. ASAE, 21(5), 838–0842.

Chittappa B.2016, Design and Development of a Motorized Onion De-Topper Cum Grader. Unpublished M. Tech. Thesis, University of Agricultural Sciences, Bengaluru.

Dabhi M, and N Patel.2017. Physical and mechanical properties of Talaja red onion cultivar. Bioprocess Engineering, 1(4): 110 – 114.

Droll R W, R E Armstrong, C G Coble and W H Aldred.1976. Mechanical onion top removal and related pre-harvest practices. Trans. ASAE, 19(6), 1048–1050.

Frank C, James, Salem, and N Mex.1969. Onion harvesting machine. U. S. Patent Sr. No. 3451485.

Hilly, M., Adams, M. L., & Nelson, S. C. (2002). A study of digit fusion in the mouse embryo. Clinical and Experimental Allergy, 32(4), 489-498.

Hiroshi T.1953. U.S. Patent No. 2,625,781. Washington, DC: U.S. Patent and Trademark Office.

Howell J, A Cavanagh, and R Hazzard.2011. Resources: CSU Extension and the University of Saskatchewan, <http://extension.umass.edu/vegetable/articles/onions-harvest-and-curingtips-best-quality>.

Kale V K, D A Kawade, T D Shinde, P S Vhanamane, and K Pagar.2018. Onion leaf cutting machine. International Research Journal of Engineering and Technology (IRJET), 5(4): 2901 – 2904.

Kido D and D Shuff.2006. U.S. Patent No. 7,007,449. Washington, DC: U.S. Patent and Trademark Office.

Kumawat L and H Raheman.2022. Mechanization in Onion Harvesting and its Performance: A Review and a Conceptual Design of Onion Harvester from Indian Perspective. J. Inst. Eng. India Ser. A, <https://doi.org/10.1007/s40030-021-00611-3>.

LePori W and P Hobgood.1970. Mechanical harvester for fresh market onions. Trans. ASAE, 13(4), 517–0519.

Londhe D, G Bhanage, and Somnath.2014. Power operated Onion Detopper-cum-grader. Lap Lambert academic publishing, pp:4430.

Londhe D, S Nalawade, G Pawar, V Atkari and S Wandkar.2014. Grader: A review of different methods of grading for fruits and vegetables. AgricEngInt: CIGR Journal, 15(3): 217 – 230.

Lorenzen.1949. California Agriculture. PP 8 – 9.

Maw B W, Y O Hung, E W Tollner, D A Smittle and B G Mullinse.1996. Physical and mechanical properties of fresh and stored sweet onion. *Trans. Of ASAE*, 39(2): 633 – 637.

Maw B W, D A Smittle, B G Mullinix, J S Cundiff.1998. Design and evaluation of principles for mechanically harvesting sweet onions. *Trans. ASAE*, 41(3), 517.

Mayhoub M A, E A El-Sahhar, A G El-Kabany, and A A Abdel-Hafez.2009. Performance evaluation of a mechanism for green onion handling. *Misir Journal of Agricultural Engineering*, 26(3): 1569 – 1585.

Medlock H G and H F Ragsdale.1976. U.S. Patent No. 3,989,110. Washington, DC: U.S. Patent and Trademark Office.

More N M, T B Bastewad, R V Sanglikar, S M Nalawade, V D Deshmukh, P B Kadam, and D DPawar. 2018. Performance evaluation of power operated detopper and grader machine for harvested onion crop. *Contemporary research in India*, PP 95 – 97.

Mozaffary M, K Kazminkhah, S A Mousavizadesh, S Abdi. 2004. Design and development of three onion toppers and selection of the best one for an onion harvester. 1-East Azarbaijan Research Centre for Agriculture and Natural Resources, Tabrin-Iran.

Nisha N and B Shridar. 2018. Development of power tiller operated harvester for small onion (*Allium cepa* var. *Aggregatum*). *Int. J. Agric*, 8(1): 73–78.

Nour M A, M S El-Shal, M A El-Shazly and M M Ali. 2020. Development and performance evaluation of a local harvesting machine for onion crop. *Plant Archives*, 20(1): 1409 – 1414.

Omar O A, S G Abdel Hamid, and G A El-Termzy. 2018. Development of an onion-crop harvester. *Misir Journal of Agricultural Engineering*, 35(1): 39 – 56.

Parab A, C Sonar, P Mane, J S Kiran, P L Saini and V Vashista. 2019. Design and development of an efficient onion harvester for Indian farms, in *Machines Mechanism and Robotics*. (Springer, Singapore), pp. 541–548.

Rani V, and A P Srivastava. 2006. Physical and mechanical properties of onion (*Allium Cepa* L.) crop relevant to mechanical detopping. *Journal of Agricultural Engineering*, 43(3): 83 – 86.

Rani V, and A P Srivastava. 2012. Design and development of onion de-topper. *AMA-Agricultural Mechanization in Asia, Africa and Latin America*, 43(3): 69.

Rani V, M Jain, and A Kumar. 2018. Design and development of tractor operated carrot digger. *Agricultural Mechanization In Asia, Africa and Latin America*, 49(3): 79 – 85.

Singhal S C. 2000. Export of onion – Challenges and strategies. *Souvenir of National Symposium on Onion and Garlic Production and Post-harvest Technology Management*.

Williams L G and D F Franklin. 1971. Bulk harvesting, handling and storage of yellow sweet-Spanish onions. *Trans. ASAE*, 14(1), 55–0059.

Wingate-Hill R. 1977. Performance of a top-lifting harvester for early onions. *J. Agric. Eng. Res*, 22(3), 271–281.

Ye I., 2017. Theoretical research and development of new design of beet tops harvesting machinery. *Mechanization in agriculture & Conserving of the resources*, 63(4): 137 – 139.

UNDER PEER REVIEW