

Heat Index Analysis and Simulations of Select areas in Iowa, United States

ABSTRACT

Heat is the primary cause of weather-related illnesses in the United States. Often, it is not just the heat but the combination of heat and humidity. The Heat Index reflects what the temperature feels like to the human body when relative humidity is factored in with air temperature, influencing the body's comfort level at any given time. Extreme heat indices lead to significant discomfort and health issues. This research aims to analyze the heat index in selected areas of Iowa. For this project, a DHT11 sensor, which measures temperature and humidity, was connected to an Arduino Uno board. The temperature sensor offers a 16-bit resolution with an accuracy of $\pm 2^{\circ}\text{C}$ and a repeatability of $\pm 1^{\circ}\text{C}$. The humidity sensor has an accuracy of $\pm 5\%$ RH at 25°C and a repeatability of $\pm 1\%$ RH. During the experiment on the Arduino Uno, the heat index averaged 72.5°F at room temperature in Iowa city, which is considered safe. Room temperature was also recorded using the TMP36 temperature sensor. Additionally, data from the Iowa Environmental Mesonet (IEM) was processed in real-time to analyze the Heat Index for Des Moines, Iowa. The code incorporated Ip widgets, which allowed for the simulation of random heat indices for any location.

Keywords: Heat Index, Heat Stress, Temperature, Relative Humidity, Temperature Sensors.

INTRODUCTION

High heat during the summer months particularly impacts outdoor workers, such as construction workers and farmers (1). Prolonged exposure to extreme heat poses significant health risks to vulnerable populations, including heat cramps, heat stress, heat stroke, and heat exhaustion, which can sometimes lead to death (2). Extreme heat events are influenced by both temperature and relative humidity. Temperature measures the warmth or coldness of a body or object, while relative humidity indicates the amount of moisture in the air relative to the maximum amount the air can hold at a specific temperature. It is expressed as a percentage. For instance, a relative humidity of 50% means the air contains half of the moisture it can hold at that temperature (3).

The heat index, or apparent temperature, represents how the temperature feels to the human body when relative humidity is factored in with the air temperature (4). This is crucial for understanding the body's comfort level (5). When the body becomes too hot, it starts to sweat to cool down. If the sweat cannot evaporate, the body loses its ability to regulate its temperature. Evaporation is a cooling process; when sweat evaporates from the body, it helps lower the body temperature. However, if the atmospheric moisture content (relative humidity) is high, the rate of evaporation decreases. In other words, the human body feels warmer in humid conditions. The opposite occurs when relative humidity decreases, as the rate of perspiration increases. These processes, in combination with temperature, contribute to the heat index (6).

There is a direct correlation between air temperature, relative humidity, and the heat index. As both air temperature and relative humidity increase, the heat index also rises. Conversely, when either temperature or relative humidity decreases, the heat index also decreases (7).

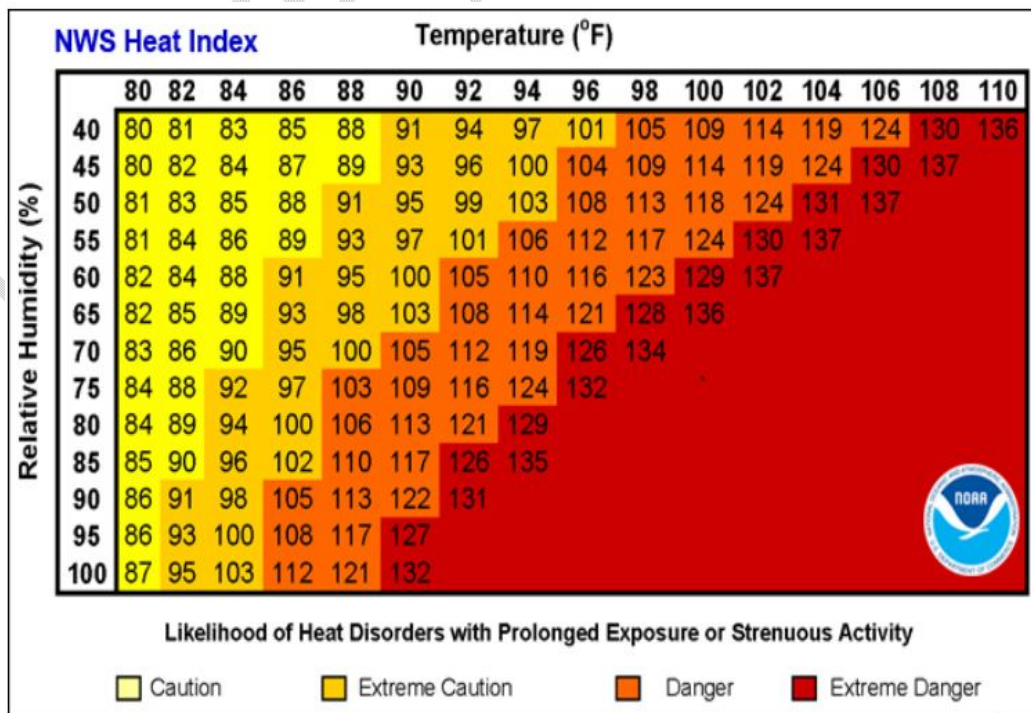

Figure 1: Heat Index Chart (weather.gov)

To read the heat index using Figure 1, you need to know the air temperature and relative humidity. For example, if the air temperature is 90°F and the relative humidity is 70%, the heat index will be 105°F. The heat index values in Figure 1 are for shaded areas; if you are exposed to direct sunlight, the heat index can increase by as much as 15°F (6).

Classification	Heat Index	Effect on the body
Caution	80°F - 90°F	Fatigue possible with prolonged exposure and/or physical activity
Extreme Caution	90°F - 103°F	Heat stroke, heat cramps, or heat exhaustion possible with prolonged exposure and/or physical activity
Danger	103°F - 124°F	Heat cramps or heat exhaustion likely, and heat stroke possible with prolonged exposure and/or physical activity
Extreme Danger	125°F or higher	Heat stroke highly likely

Figure 2: Heat Index Classifications (Weather.gov)

Heat indices reaching or exceeding 105°F can result in hazardous heat-related disorders with prolonged exposure and/or physical activity in the heat (8).

The Iowa Environmental Mesonet (IEM) gathers environmental data, including temperature, relative humidity, soil moisture, and solar radiation, from collaborating members with observation networks. This data is stored and made accessible on the Iowa Mesonet website, allowing weather and environmental scientists to process the information and make informed decisions for their projects and research (9).

The motivation for this project was to apply the knowledge from my data science and mechatronics class in determining heat indices of select areas. For this project, I set out to script, analyze and simulate a functional heat index in a select area in Des Moines, Iowa on python, and to design and simulate temperature and Heat Index using a thermistor and DHT 11 (Temperature & Humidity Sensor) on an Arduino Uno.

Methodology:

My experimental set up involved reading a room temperature and displaying values on an LCD using the TMP 36 temperature sensor then finally setting up the DHT 11 for temperature and humidity readings to analyze heat index.

For my python script, data from Iowa Environmental Mesonet (IEM) was used to analyze and simulate Heat Index in a select area in Des Moines, Iowa. Analysis includes plotting the top ten hottest air temperatures, top ten dewpoint temperatures, defining a function to calculate relative humidity from air temperature and dew point temperatures, and a function to calculate and simulate heat index from the relative humidity and air temperatures, then created Ipywidgets for real time simulation of heat index

TEMPERATURE SENSING WITH TMP36

For my room temperature sensing, I made use of TMP36 Temperature sensor. The temperature sensor, as shown in Figure 3, has three legs: one connected to 5V, one to ground, and the voltage output from the third leg changes proportionally with temperature variations. This voltage value is then converted into a temperature reading using simple temperature-retrieving algorithms, as outlined in the TMP36 datasheet (10). Figure 4 shows the circuit diagram for the TMP36 with an LCD Display for the Room temperature in centigrade and Fahrenheit.



Figure 3: TMP 36 Temperature sensor (Source: (10))

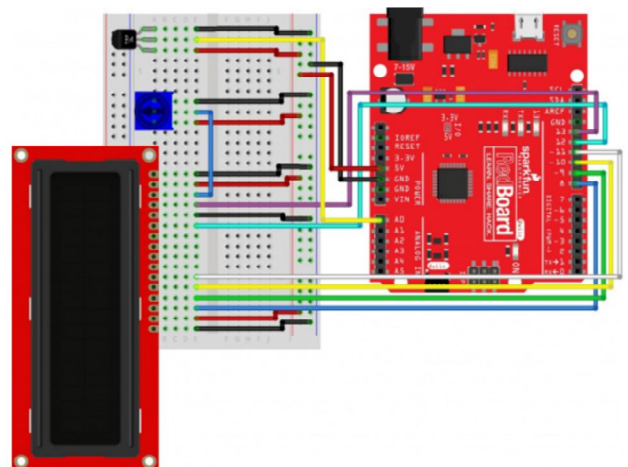
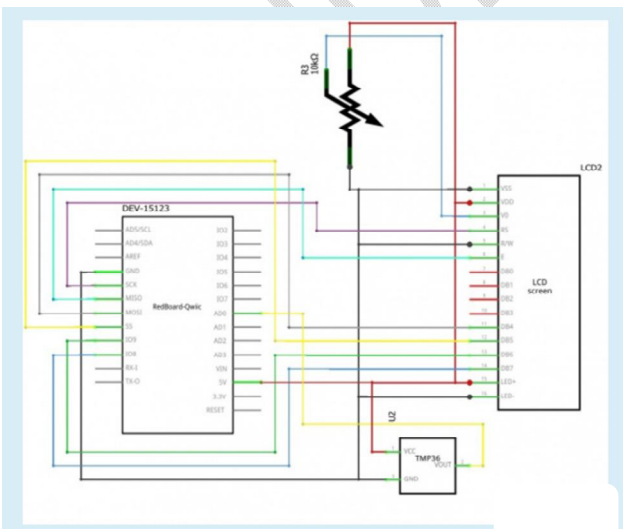

Figure 4: Circuit Diagram for TMP 36 Temperature sensor with LCD. (Source: (10))

DHT 11 - TEMPERATURE AND HUMIDITY SENSOR

The DHT11 digital temperature and humidity sensor provides a calibrated digital signal output for both temperature and humidity measurements. The sensor incorporates a resistive element and a Negative Temperature Coefficient (NTC) temperature sensing device, along with a high-performance 8-bit microcontroller. The DHT11 consists of four pins: VDD for power supply (3.3-5V DC), DATA for serial data transmission on a single bus, an NC (Not Connected) pin, and the ground pin, as shown in Figures 5 and 6. The sensor is connected to the Arduino Uno and to the PC via the IDE and code to measure the room temperature and relative humidity, and calculate the heat index as shown in Figure 7.

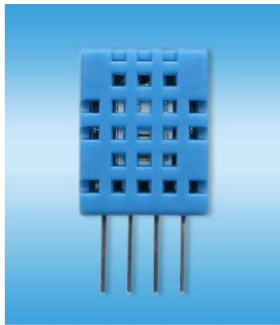

Figure 5: DHT 11 (Source: Datasheet)

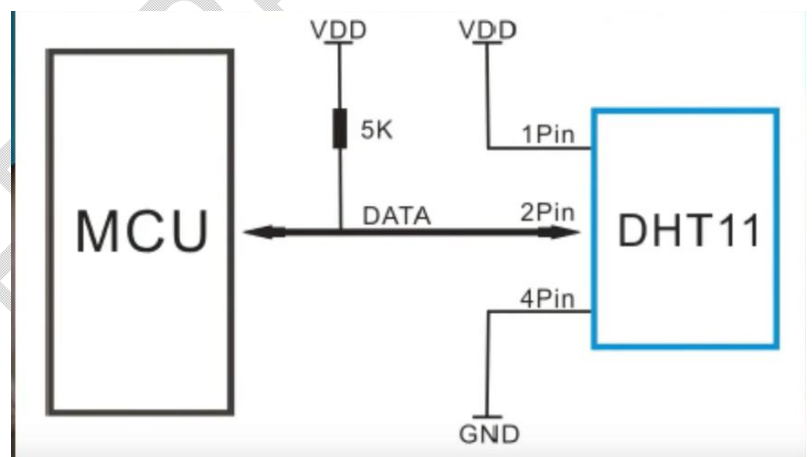

Figure 6: Circuit Diagram for DHT 11 (Source: Datasheet)

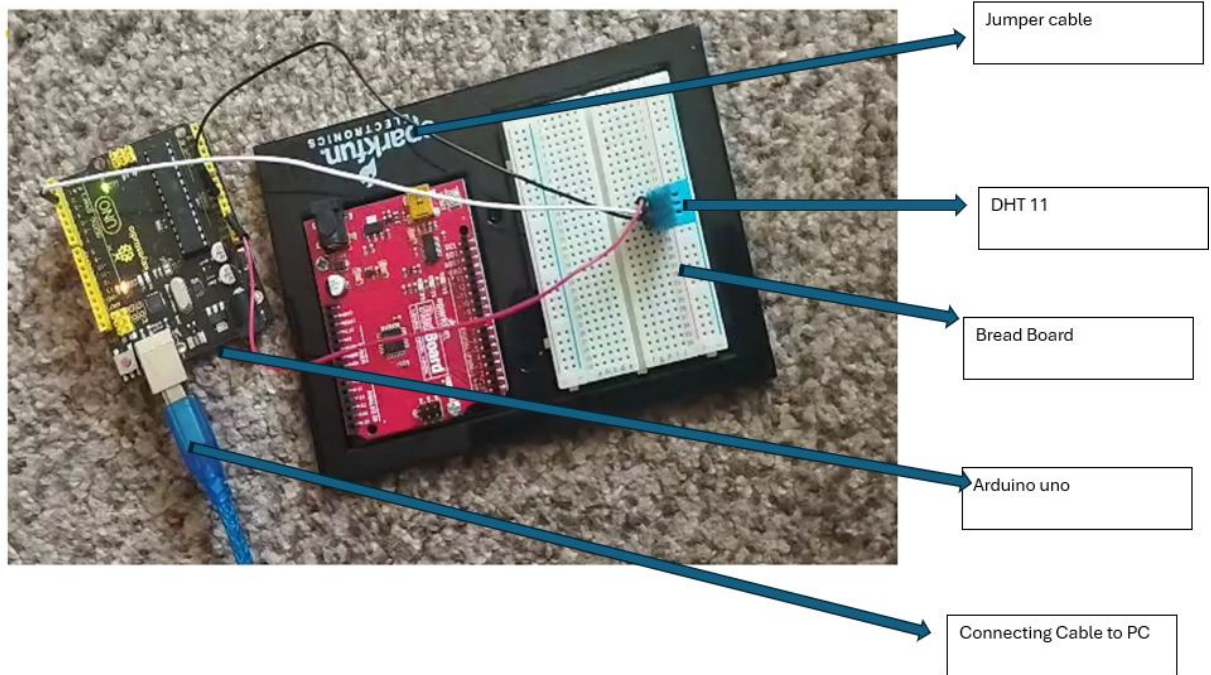

Figure 7: DHT 11 connected to Arduino Uno

RESULTS:

TMP36 TEMPERATURE SENSOR

The TMP36 sensors employ a solid-state technique to measure room temperature. Unlike traditional thermometers that use mercury, bimetallic strips, or thermistors (temperature-sensitive resistors), these sensors take advantage of the fact that as temperature rises, the voltage across a diode increases at a known rate. By carefully amplifying this voltage change, an analog signal is generated that is directly proportional to the temperature, as illustrated in Fig. 8, an LCD was equally utilized to display the room temperature alongside the display on the Serial monitor on the Arduino IDE.

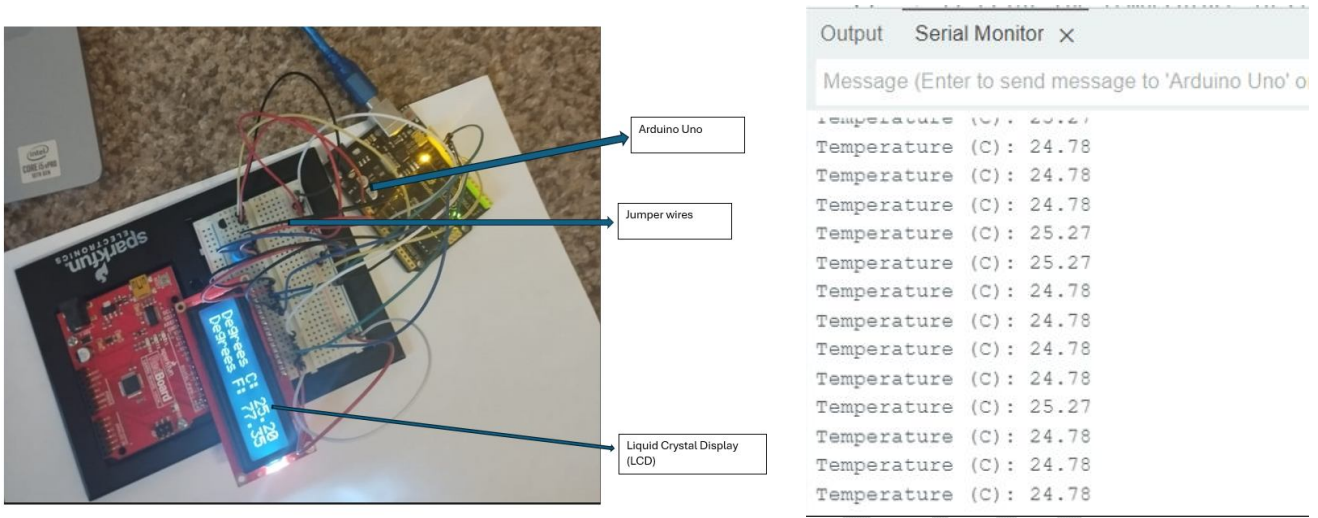

Fig 8: Room Temperature Readings from TMP 36

DHT 11 SENSOR READINGS: The DHT11 sensor, on the other hand, provided real-time temperature and humidity values. The code incorporated the capability to calculate the heat index based on these real-time measurements, as shown in Fig. 9. At the time of measurement, the heat index was considered normal.

UNDER PEER REVIEW

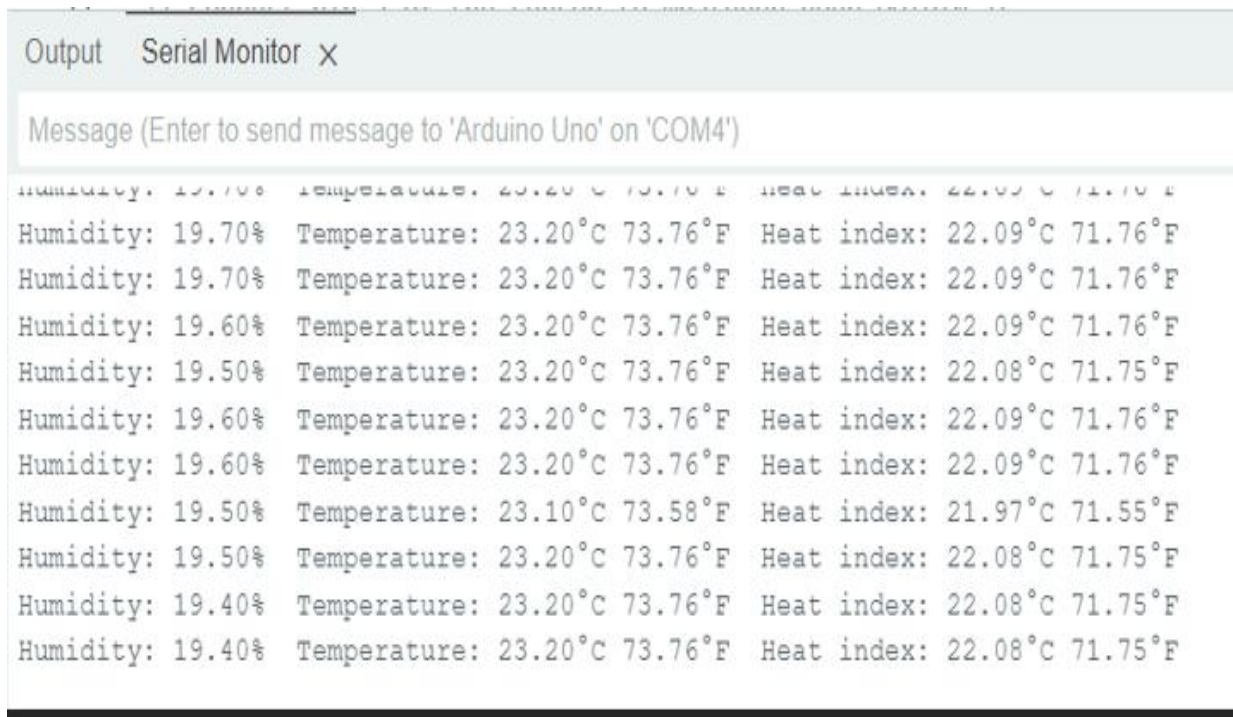

Fig 9: Serial Monitor display of Heat Index calculations from DHT 11 sensor

PYTHON SCRIPT:

A station (RDS14) in Des Moines Iowa from the Iowa Environmental Mesonet Network simulated and A station (RDS14) in Des Moines, Iowa, from the Iowa Environmental Mesonet Network was used to simulate and analyze the heat index in that area. It displays the heat index along with the corresponding cautions, as shown in Figures 10a to 10d. Figure 10d utilizes ipywidgets to control the heat index settings.

For Air Temperature: 26°F and Humidity: 100%, the Heat Index is: 26.00°F

3D Visualization of Heat Index
(Air Temp: 26°F, Humidity: 100%)

● Given Point

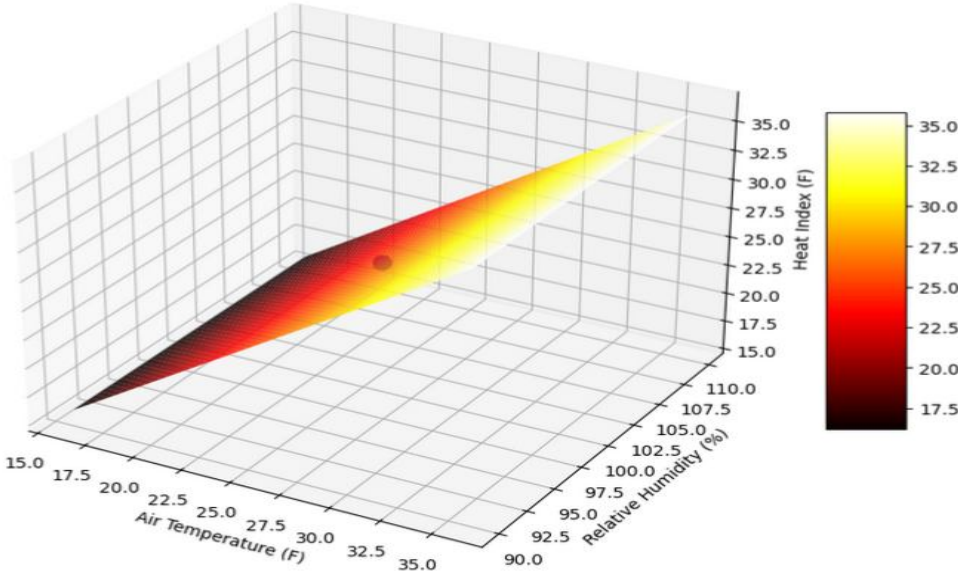

Figure 10a 3D visualization of Heat index (Air Temp. 26°F, Humidity 100%)

Air Temperature (F) and Relative Humidity (%) with corresponding Heat Index (F):
Air Temp: 95.00F, Humidity: 90.00%, Heat Index: 146.60F
Air Temp: 94.49F, Humidity: 90.20%, Heat Index: 144.15F
Air Temp: 93.98F, Humidity: 90.41%, Heat Index: 141.73F
Air Temp: 93.47F, Humidity: 90.61%, Heat Index: 139.33F

Heat Index Sensor Simulation

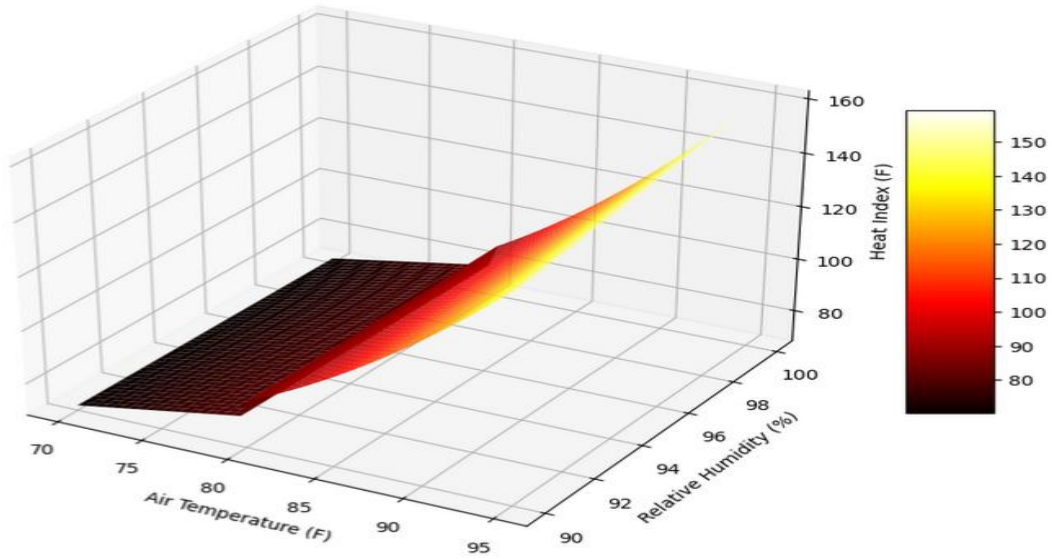

Figure 10b Heat index sensor simulation

For Air Temperature: 140°F and Humidity: 90%, the Heat Index is: 566.09°F
Alert: Extreme Danger: Heat stroke highly likely with continued exposure.

3D Visualization of Heat Index
(Air Temp: 140°F, Humidity: 90%)

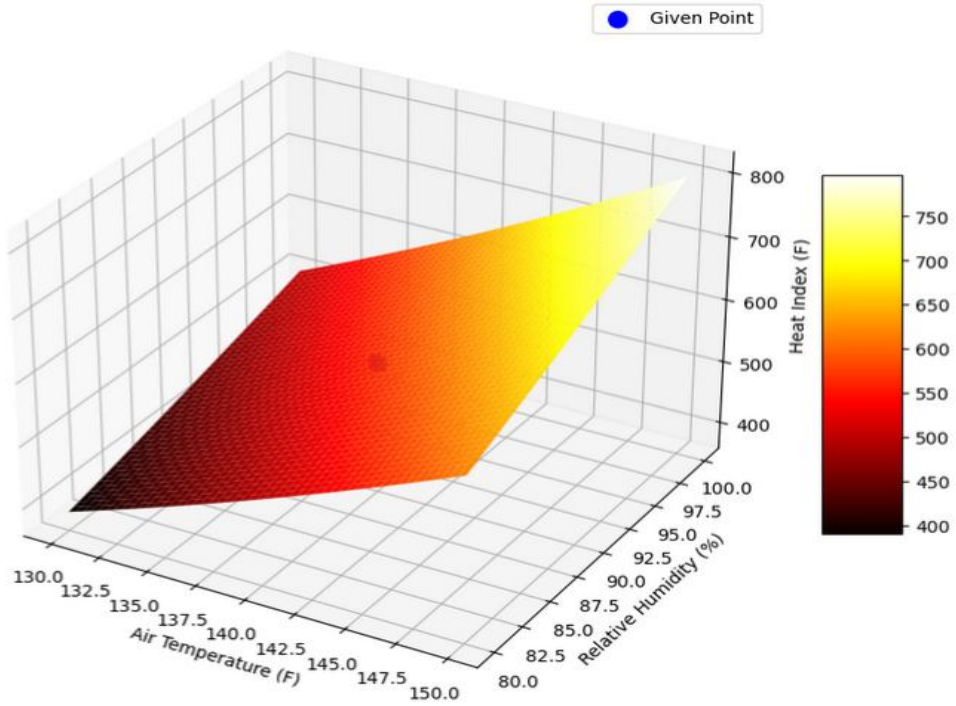

Figure 10c 3D visualization of Heat index (Air Temp: 140°F, Humidity: 90%)

Air Temp (°F) ——— 109.00 Humidity (%) ——— 70.00
For Air Temperature: 109.0°F and Humidity: 70.0%, the Heat Index is: 187.81°F
Alert: Extreme Danger: Heat stroke highly likely with continued exposure.

3D Visualization of Heat Index
(Air Temp: 109.0°F, Humidity: 70.0%)

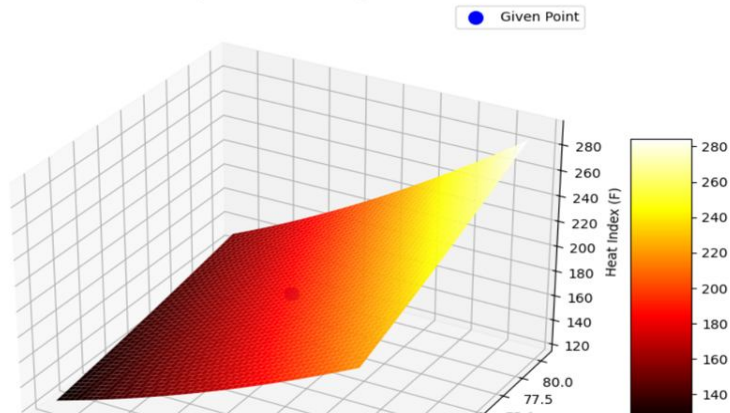

Figure 10d: 3D visualization of heat index (Air Temp: 109.0°F, Humidity: 70.0%)

DISCUSSIONS

Figure 10d 3D visualization of Heat index

The room temperature readings from the TMP 36 gave real time temperatures and displayed values in centigrade and Fahrenheit on the LCD attached as shown in fig.8. For confirmation, I brought a space heater near the temperature sensor to vary ambient temperatures, it was also quick to identify the change. Care should be taken when connecting TMP36 to the board, ensure to follow the right direction to avoid overheating, I personally observed that if the pins are wrongly situated, the heat it emanates can be somewhat harmful when touched.

DHT11 is an excellent choice for experimentally determining the heat index in a small area or for basic data logging. This is due to its capacitive humidity sensor and thermistor. The digital signal is relatively easy to read using some microcontrollers. The DHT11 is affordable, operates on 3-5V power, and provides humidity readings in the range of 20-80% with 5% accuracy. It also measures temperatures from 0-50°C with an accuracy of +/- 2°C. However, it requires the correct code to function properly.

Arduino Uno was a better microcontroller than sparkfun, I couldn't use sparkfun in most of the setups, as it wasn't compatible for some reasons, but Arduino uno was swift to use. The heat index in Des Moines as analyzed on python is generally highest during the summer period and lowest at winter.

CONCLUSIONS

Extreme heat events are likely to occur during the summer months in the United States. It is crucial to advise citizens, particularly outdoor workers, the elderly, children, and other vulnerable groups, about the dangers of excessive heat. Heat indices are useful for determining safe outdoor conditions during the summer, making it important for people to be informed. Having devices like the Triplet HS10 or WS-HE01, which can provide this information, can significantly help alert the public on how to safely conduct their activities.

Disclaimer (Artificial intelligence)

Option 1:

Author(s) hereby declare that NO generative AI technologies such as Large Language Models (ChatGPT, COPILOT, etc.) and text-to-image generators have been used during the writing or editing of this manuscript.

Option 2:

Author(s) hereby declare that generative AI technologies such as Large Language Models, etc. have been used during the writing or editing of manuscripts. This explanation will include the name, version, model, and source of the generative AI technology and as well as all input prompts provided to the generative AI technology

Details of the AI usage are given below:

- 1.
- 2.
- 3.

REFERENCES

- (1) Takle, G.; Thorne, P. Iowa Climate Statement 2019: Dangerous Heat Events Will Be More Frequent and Severe. *Center for Global and Regional Environmental Research*. September 11, 2019.
- (2) Luber, G.; McGeehin, M. Climate Change and Extreme Heat Events. *American Journal of Preventive Medicine* **2008**, 35 (5), 429–435. <https://doi.org/10.1016/j.amepre.2008.08.021>.
- (3) Westcott, N. E. The Prolonged 1954 Midwestern U.S. Heat Wave: Impacts and Responses. *Weather, Climate, and Society* **2011**, 3 (3), 165–176. <https://doi.org/10.1175/wcas-d-10-05002.1>.
- (4) Awasthi, A.; Vishwakarma, K.; Pattnayak, K. C. Retrospection of Heatwave and Heat Index. *Theoretical and Applied Climatology* **2021**, 147 (1-2), 589–604. <https://doi.org/10.1007/s00704-021-03854-z>.
- (5) Sheridan, S. C. A Survey of Public Perception and Response to Heat Warnings across Four North American Cities: An Evaluation of Municipal Effectiveness. *International Journal of Biometeorology* **2006**, 52 (1), 3–15. <https://doi.org/10.1007/s00484-006-0052-9>.
- (6) US Department of Commerce, N. *What is the heat index?* www.weather.gov. <https://www.weather.gov/ama/heatindex>. accessed October 12, 2024.
- (7) Kuras ER, Richardson MB, Calkins MM, Ebi K, Hess JJ, et al., (2017) Opportunities and challenges for personal heat exposure research. *Environ Health Perspect*. 2017 Aug 1;125(8): 085001. <https://doi.org/10.1289/EHP556>
- (8) Anderson, G. B.; Bell, M. L.; Peng, R. D. Methods to Calculate the Heat Index as an Exposure Metric in Environmental Health Research. *Environmental Health Perspectives* 2013, 121 (10), 1111–1119. <https://doi.org/10.1289/ehp.1206273>.

- (9) Daryl Herzmann akrherz@iastate.edu. *IEM* :: Iowa DOT RWIS Data. Iastate.edu.
<https://mesonet.agron.iastate.edu/RWIS/> (accessed 2024-11-30)
- (10) *SparkFun Inventor's Kit Experiment Guide - v4.1 - SparkFun Learn.*
learn.sparkfun.com. <https://learn.sparkfun.com/tutorials/sparkfun-inventors-kit-experiment-guide---v41/circuit-4b-temperature-sensor>

Appendix:

UNDER PEER REVIEW

APPENDICES

APPENDIX A DATASHEET OF DHT 11

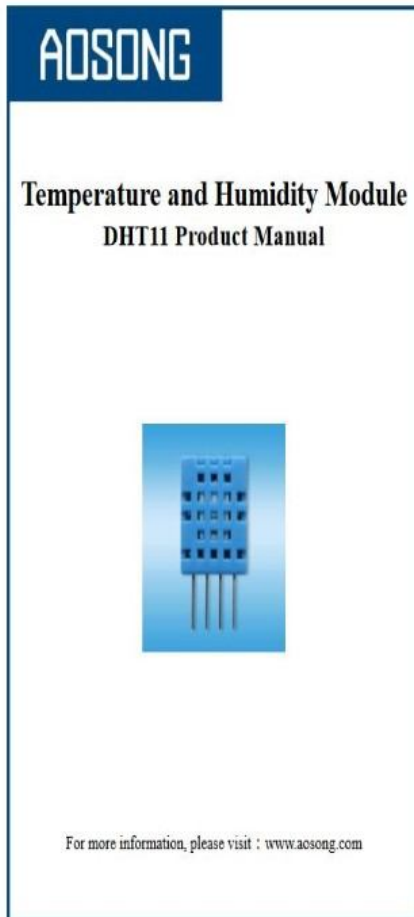

Temp., Humidity & Dew point measurement experts

Supply current : Measure 0.3mA Standby 60 μ A

Sampling period : Secondary Greater than 2 seconds

Pin Description

1. VDD supply 3.3 ~ 5.5V DC
2. DATA serial data, single-bus
3. NC NC
4. GND grounding, power negative

6. Typical circuit

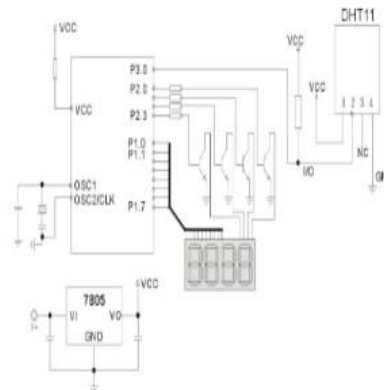

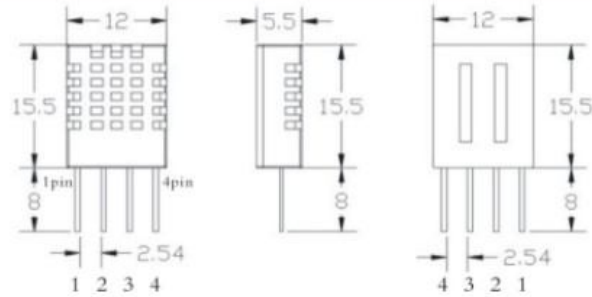

5. Parameters

Relative Humidity

Resolution : 16Bit

Repeatability : $\pm 1\%RH$

Accuracy : 25°C $\pm 5\%RH$

Interchangeability : Fully interchangeable

Response time : 1/e (63%)25°C 6s

1m/s Air 6s

Hysteresis : $\leq 0.3\%RH$

Long-term stability : $\leq 0.5\%RH/yr$

Temperature

Resolution : 16Bit

Repeatability : $\pm 1^\circ C$

Accuracy : 25°C $\pm 2^\circ C$

Response time : 1/e (63%) 10S

Electrical Characteristics

Power supply : DC 3.3 ~ 5.5V

UNID

FEATURES

- Low voltage operation (2.7 V to 5.5 V)
- Calibrated directly in °C
- 10 mV/°C scale factor (20 mV/°C on TMP37)
- ±2°C accuracy over temperature (typ)
- ±0.5°C linearity (typ)
- Stable with large capacitive loads
- Specified -40°C to +125°C, operation to +150°C
- Less than 50 µA quiescent current
- Shutdown current 0.5 µA max
- Low self-heating
- Qualified for automotive applications

APPLICATIONS

- Environmental control systems
- Thermal protection
- Industrial process control
- Fire alarms
- Power system monitors
- CPU thermal management

GENERAL DESCRIPTION

The TMP35/TMP36/TMP37 are low voltage, precision centi-grade temperature sensors. They provide a voltage output that is linearly proportional to the Celsius (centigrade) temperature. The TMP35/TMP36/TMP37 do not require any external calibration to provide typical accuracies of ±1°C at +25°C and ±2°C over the -40°C to +125°C temperature range.

The low output impedance of the TMP35/TMP36/TMP37 and its linear output and precise calibration simplify interfacing to temperature control circuitry and ADCs. All three devices are intended for single-supply operation from 2.7 V to 5.5 V maximum. The supply current runs well below 50 µA, providing very low self-heating—less than 0.1°C in still air. In addition, a shutdown function is provided to cut the supply current to less than 0.5 µA.

The TMP35 is functionally compatible with the LM35/LM45 and provides a 250 mV output at 25°C. The TMP35 reads temperatures from 10°C to 125°C. The TMP36 is specified from -40°C to +125°C, provides a 750 mV output at 25°C, and operates to 125°C from a single 2.7 V supply. The TMP36 is functionally compatible with the LM50. Both the TMP35 and TMP36 have an output scale factor of 10 mV/°C.

FUNCTIONAL BLOCK DIAGRAM

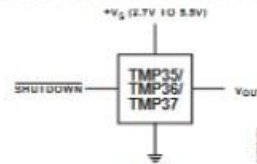

Figure 1.

PIN CONFIGURATIONS

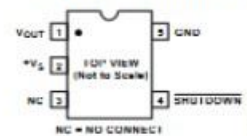

Figure 2. R3-5 (SOT-23)

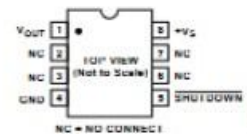

Figure 3. R-8 (SOIC_N)



Figure 4. T-3 (TO-92)

The TMP37 is intended for applications over the range of 5°C to 100°C and provides an output scale factor of 20 mV/°C. The TMP37 provides a 500 mV output at 25°C. Operation extends to 150°C with reduced accuracy for all devices when operating from a 5 V supply.

The TMP35/TMP36/TMP37 are available in low cost 3-lead TO-92, 8-lead SOIC_N, and 5-lead SOT-23 surface-mount packages.

Rev. F

Information furnished by Analog Devices is believed to be accurate and reliable. However, no responsibility is assumed by Analog Devices for its use, nor for any infringements of patents or other rights of third parties that may result from its use. Specifications subject to change without notice. No license is granted by implication or otherwise under any patent or patent rights of Analog Devices. Trademarks and registered trademarks are the property of their respective owners.

One Technology Way, P.O. Box 9106, Norwood, MA 02062-9106, U.S.A.
Tel: 781.329.4700 www.analog.com
Fax: 781.461.3113 ©1996–2010 Analog Devices, Inc. All rights reserved.

SPECIFICATIONS

$V_S = 2.7\text{ V to }5.5\text{ V}$, $-40^\circ\text{C} \leq T_A \leq +125^\circ\text{C}$, unless otherwise noted.

Table 1.

Parameter ¹	Symbol	Test Conditions/Comments	Min	Typ	Max	Unit
ACCURACY						
TMP35/TMP36/TMP37 (F Grade)		$T_A = 25^\circ\text{C}$		± 1	± 2	$^\circ\text{C}$
TMP35/TMP36/TMP37 (G Grade)		$T_A = 25^\circ\text{C}$		± 1	± 3	$^\circ\text{C}$
TMP35/TMP36/TMP37 (F Grade)		Over rated temperature		± 2	± 3	$^\circ\text{C}$
TMP35/TMP36/TMP37 (G Grade)		Over rated temperature		± 2	± 4	$^\circ\text{C}$
Scale Factor, TMP35		$10^\circ\text{C} \leq T_A \leq 125^\circ\text{C}$		10		mV/ $^\circ\text{C}$
Scale Factor, TMP36		$-40^\circ\text{C} \leq T_A \leq +125^\circ\text{C}$		10		mV/ $^\circ\text{C}$
Scale Factor, TMP37		$5^\circ\text{C} \leq T_A \leq 100^\circ\text{C}$		20		mV/ $^\circ\text{C}$
		$3.0\text{ V} \leq V_S \leq 5.5\text{ V}$		20		mV/ $^\circ\text{C}$
Load Regulation		$0\ \mu\text{A} \leq I_L \leq 50\ \mu\text{A}$				
		$-40^\circ\text{C} \leq T_A \leq +105^\circ\text{C}$		6	20	m $^\circ\text{C}/\mu\text{A}$
		$-105^\circ\text{C} \leq T_A \leq +125^\circ\text{C}$		25	60	m $^\circ\text{C}/\mu\text{A}$
Power Supply Rejection Ratio	PSRR	$T_A = 25^\circ\text{C}$		30	100	m $^\circ\text{C}/\text{V}$
		$3.0\text{ V} \leq V_S \leq 5.5\text{ V}$		50		m $^\circ\text{C}/\text{V}$
Linearity				0.5		$^\circ\text{C}$
Long-Term Stability		$T_A = 150^\circ\text{C}$ for 1 kHz		0.1		$^\circ\text{C}$
SHUTDOWN						
Logic High Input Voltage	V_{IH}	$V_S = 2.7\text{ V}$	1.8			V
Logic Low Input Voltage	V_{IL}	$V_S = 5.5\text{ V}$			400	mV
OUTPUT						
TMP35 Output Voltage		$T_A = 25^\circ\text{C}$		250		mV
TMP36 Output Voltage		$T_A = 25^\circ\text{C}$		750		mV
TMP37 Output Voltage		$T_A = 25^\circ\text{C}$		500		mV
Output Voltage Range			100		2000	mV
Output Load Current	I_L		0		50	μA
Short-Circuit Current	I_{SC}	Note 2			250	μA
Capacitive Load Driving	C_L	No oscillations ²	1000	10000		pF
Device Turn-On Time		Output within $\pm 1^\circ\text{C}$, 100 k Ω 100 pF load ²		0.5	1	ms
POWER SUPPLY						
Supply Range	V_S		2.7		5.5	V
Supply Current	I_{SR} (ON)	Unloaded			50	μA
Supply Current (Shutdown)	I_{SR} (OFF)	Unloaded		0.01	0.5	μA

¹ Does not consider errors caused by self-heating.

² Guaranteed but not tested.

UNL