DEVELOPMENT OF A PALM OIL CLARIFIER UNIT FOR SMALL SCALE PALM OIL PROCESSORS

ABSTRACT

In most palm oil processing countries in Africa, a huge quantity of the oil is processed informally by small-scale processors which contribute significantly to national production. Unfortunately processing losses by small-scale processors are very high, reaching 15% of total crude palm oil production. Such huge losses account for the fact that the sector contributes barely 50% of the total crude palm oil production despite occupying up to 70% of the cultivated area. Palm oil clarification as a unit operation generates more than 50% of the palm oil mill wastewater. It therefore contributes enormously to oil losses in palm oil processing. The objective of this research therefore was to design a more efficient palm oil clarifier suitable for use by small-scale processors in order to curb oil losses. A two-chamber prototype palm oil clarifier, integrated with a palm oil dryer has been developed. Performance evaluation with oil from a screw press puts the throughput, extraction rate and clarifier efficiency at 0.82, 16.33 and 74.24% respectively when the clarification temperature is 85°C at mole ratio 1:2. This equipment can be very useful to non-industrial palm oil producers who are unable to afford sophisticated equipment. Adequate clarifier design can significantly improve on the performance of non-industrial palm oil mills.

Key-words: clarifier efficiency, extraction rate, palm oil clarifier, performance evaluation, through put.

INTRODUCTION

The production of palm oil in Africa dates back to the pre-industrial revolution era and before the advent of colonization in the continent. During this period, the oil was traditionally produced by the use of rudimentary tools. Palm oil is utilized in a variety of goods, including packaged goods, fast food, and cosmetics (Kavuma & Barakagira, 2024). The most popular oil palm species in the world is *Elaeis guineensis*, which is native to the Gulf of Guinea (Nkongho *et al.*, 2014a; Rafflegeau *et al.*, 2018). This species is cultivated extensively across West and Central Africa particularly in countries like Nigeria, Ghana, Ivory Coast, and Cameroon who stand out as the major producers of palm oil in the region (Nchanji *et al.*, 2013; Ekka and Sharma, 2020). In Cameroon however, the government saw the need to develop the smallholder oil palm sector in the 1970s. This initiative provided funding to selected agro-industrial companies in the sector through a farmers' bank the National Fund for Agriculture and Rural Development (FONADER); to enable them technically supervise land owners interested in oil palm farming (Nkongho *et al.*, 2014a; Nkongho *et al.*, 2014c). Though the initial intention was to improve palm oil production by increasing the surface area under cultivation as well as increase the yield per hectare, the initiative ended up encouraging the proliferation of non-industrial palm oil milling in the country instead. This was because of several reasons including but not limited to poor treatment of the smallholder farmers by the agro-industrial companies who were supposed to receive their fresh fruit bunches (FFB) for processing, very high interest rates on the FONADER loans, and most especially the realization by the farmers that more profit could be generated from milling their FFB themselves (Hassan *et al.*, 2016; Nchanji *et al.*, 2013; Nkongho *et al.*, 2014a; Nkongho *et al.*, 2014b; Nkongho *et al.*, 2014c; Rafflegeau *et al.*, 2018). The

establishment of small scale palm oil mills was further encouraged by the emergence of a group of new oil palm farmers especially in non-traditional oil palm areas in the country such as the north western region comprising the Mbaw plane and Ako Sub-Division all in the Donga Mantung Division.

Thus in most oil processing communities in Africa such as Ghana, Nigeria, Cameroon etc, three categories of palm oil millers can be identified (Njeshu *et al.*, 2023; Rafflegeau *et al.*, 2018; Ekka and Sharma, 2020): the traditional millers who use methods which are basically manual with the aid of rudimentary tools, the small-scale (or non-industrial) millers who use a variety of low-efficiency machinery ranging from simple hand presses and other stand-alone machines, to a very varied combination of machines for the different unit operations in the processing chain; and lastly the industrial mills with technologically up-to-date machinery, established by agro-industrial complexes for the production of palm oil that normally meets international norms to supply downstream industries in the sector. A more comprehensive categorization of millers has been proposed that uses the mill through put as the criterion. Millers with through put less than 500kg of threshed fruit nuts per day are traditional, those with through puts ranging between 1 ton fresh fruit bunch per hour (FFB/hour) and 4 ton FFB/hour, are considered to be non-industrial or small scale millers while through put of more than 4 ton FFB/hour are industrial millers.

In palm oil production, losses are tracked by recording how much oil could be recovered at each of three different stages viz: at harvest (FFB production), in transit (FFB transportation) and in the mill (FFB processing) (Maire and Lee, 2019). With regards to losses in the mill, due to differences in the level of sophistication of the machinery involved, significant differences exist in the process flow for non-industrial and industrial palm oil processing; leading to a

corresponding difference in oil losses along the process line. Oil loss in sludge accounts for up to 90% of total oil losses in the mill (Rashidi, 2020; Yunus, 2019); and more than 70% of the sludge is generated during palm oil clarification.

Palm oil clarification involves the separation of the diluted crude palm oil (CPO) emanating from the press; into pure oil and sludge water. In the process, the impurities contained in the oil and oil loss in sludge water must be reduced to a minimum. The entire clarification process is subject to simple natural laws of sedimentation and decantation and with the aid of an efficient setup based on these laws; we can strive for an optimum clarifying effect.

In an industrial setting, palm oil clarification starts with static decantation in the settling tank which is then followed by dynamic decantation using centrifugal machines (like WESFALIA decanters); for final purification of the clarified oil. This is followed by the use of a sludge centrifuge for the recovery of residual oil in the sludge water leaving the clarification section of the mill. In non-industrial processing palm oil clarification is simplified and limited to static decantation in a settling tank. This is one way to reduce the very high cost of the sophisticated machinery involved in industrial processing which makes it unaffordable for small mill owners.

Within the palm oil belt in Africa, small scale farmers own more than 60% of the surface area occupied by palms, and more than 70% of the palm oil in the market is produced by small scale mills in these countries (Ordway *et al.*, 2017). Thus an improvement in the efficiency of the equipment used by small scale millers will have a very huge economic impact in the sector. Clarification as a unit operation in small scale palm oil processing has not been a subject of proper research despite constituting a major source of oil losses (Manaf and Chung, 2018). Local mills around the palm oil producing regions especially in Cameroon still boil press liquor in metallic drums for clarification. This leads to significant losses which negatively impacts the

income of the farmers. To improve on these losses, there is a need to improve on the clarification process for these small scale processors. Unfortunately, the established industrial clarification processes are sophisticated and expensive which make it difficult to be adapted for small scale oil clarification. The design of customized and affordable clarifiers for small-scale processors is therefore appealing as this will not only reduce the drudgery involved in oil clarification at that level but is also expected to greatly improve the oil yields and consequently the household incomes of the processors. In a previous work, our group carefully and rigorously established the optimum palm-oil clarification conditions and procedures for small-scale holder farmers at a laboratory level (Tah *et al.*, 2024). This work utilizes these conditions to design a clarifier for small-scale holder famers because, to the best of our knowledge, there is limited information on such in the literature. The aim of this work therefore is to develop and evaluate the performance of a palm oil clarifier unit for small scale oil palm farmers.

MATERIALS AND METHOD

Clarifier Design Considerations

Al-Zuhair (1998), Dick (1974), and WEF (2005) observed that clarifier design has so far been done more empirically than rationally. This contributes to inefficiencies in the functioning of the settling tanks observed as oil losses in clarifier sludge in palm oil mills (POMs). The main reason advanced for this is a lack of understanding of the characteristics of the fluid to be clarified and consequently the kind of pollutants the clarifier is expected to eliminate. In reality, POM clarifiers ought to be designed to remove all of the settleable total suspended solids (TSS) from the CPO (WEF, 2005). Since the concentration of settleable TSS is a characteristic of the CPO, good clarifier design must begin with a characterization of the CPO. A well designed and

correctly operated CPO clarifier therefore should be able to eliminate all settleable TSS under the sole influence of gravity so that only the non-settleable TSS concentration is found in the effluent CPO (WEF, 2005).

Design Parameters

Chung (2006) observed that in as much as the settling area of the clarifier is adequate, all settling will be type 1 settling and hindered settling will not occur. In type 1 settling, the particles settle individually without interactions and thus the size, shape and specific gravity of the particles will not change with time and the settling velocity remains constant. Any particle in the press liquor, whose density is different from the density of the CPO mixture, experiences an acceleration and once motion is initiated, the particle will experience a drag force, which opposes the net force that initiated the particle acceleration. Thus the particle acceleration decreases until a steady velocity is attained when the net force on the particle and the drag force are equal in magnitude. This is the terminal speed of the droplets in the CPO mixture. These speeds vary for different methods of CPO extraction and Chung (2006) quotes these speeds for the various extraction methods as 8.5, 7.5 and 0.5m/s for centrifugal, hydraulic and the screw press respectively and 0.2 m/s for the wet process. For a screw press extraction, the dynamic viscosity of the sludge was obtained as 0.036 decipoise and a maximum particle size of 77.56 μm .

For type 1 settling, clarifier design is based essentially on the use of the Camp-Hazen ideal continuous sedimentation tank model in which the residence time, t as in equation (1), derived from the vertical settling motion of the oil droplets is equated to the horizontal plug flow movement which comes as a result of the drag on the liquid at steady state; i.e.

$$t = \frac{H}{u_t} \text{ vertically } \dots\dots\dots(1)$$

and equation (2):

$$t = \frac{AH}{Q} \text{ horizontally } \dots\dots\dots(2)$$

From equations (1) and (2) we obtain an expression for the clarifier area, A as in equation (3):

$$A = \frac{Q}{u_t} \dots\dots\dots(3)$$

Where H is the clarifier height, Q is the volumetric flow rate of liquid through the tank and u_t is the terminal settling velocity of the particle.

For a 30 ton per hour POM having an extraction rate of 20% and dilution ratio of 1:1 of water to oil, with CPO content of 80.15% oil, 13.55% moisture and 6.3% solids (Chung, 2006); the mass flow rate to the clarifier is 13.5t/h; requiring a clarifier diameter of 5.9m. This is too large to achieve practically; but if we consider a mini-mill of 2t/h capacity at the same extraction rate and dilution ratio then;

Quantity of fluid to clarifier will be (0.2 x 80.15% of 2 tons) + (13.55% of 2 tons). Thus 0.9 ton of liquid will be received by the clarifier hourly. If the mill uses a screw press, the settling speed for particles will be 0.5m/s and thus required clarifier area is 0.9/0.5 m² or 1.82 m². The determinant factor of the clarifier area required is the free settling rate of solids in the suspension. The area in turn determines the efficiency of the clarifier. The diameter of the

clarifier can be obtained from $A = \frac{\pi D^2}{4}$

Thus for an area of 1.82m^2 , the diameter is obtained as 1.51m. The recommended settling time, T for a CPO clarifier ranges between 2 and 3 hours (Chung, 2006). After this time 99.3% of the palm oil would have been recovered. Thus if the density of the diluted CPO mixture is assumed to be 1000kgm^{-3} , then the volume of the clarifier is $V_c = QT = 0.9 \text{ t/h} \times 2 = 1.82\text{m}^3$. This gives a clarifier height ($H = V_c/A$) of 1 m.

From the above calculations, it can be concluded that a 2 t/h POM can be adequately served by a clarifier with the following specifications: clarifier area 1.82 m^2 , clarifier volume 1.82 m^3 , for a retention time of 2 hours, clarifier height of 1m and diameter 1.5m; for a flow rate of 1t/h.

For the purpose of this research, an appropriate scaling led to the construction of a prototype clarifier with a total surface area of 0.2 m^2 . The diameter of the prototype was obtained as 0.4 m, while its volume and height were 0.01m^3 and 0.8m respectively.

Design of Clarifier Tanks

The selection of materials for the clarifier was based on calculations with the strength, durability and availability of the material taken into consideration. Fabrication of the clarifier included operations like measurements, marking-out, cutting, shaping, folding, drilling, grinding and welding of the plates and the clarifier frame. Two clarifier tanks (primary and secondary) are used to enhance the clarification process.

The optimal shape for the clarifier tanks is cylindrical since this can support the most weight because its walls do not have any corners. This means the force of the liquid is evenly shared across the cylinder. Square, rectangular or triangular tanks carry the weight of their content on their corner spots. Cylindrical-shaped tanks have the most uniform stress distribution when compared to rectangular or square tanks. This is because liquid pressure acts equally in all

directions, so the pressure distribution at the walls will be equal. The cylinders are further made cone-bottomed in order to ease complete drainage by eliminating low spots where sediment can accumulate. Conical tanks are unique in that their contents discharge completely through the cone on the base of the tank due to their cone base and smooth internal walls. This has clear advantages for food production. Cylindrical tanks are better at resisting stress than rectangular tanks. Thus, require less material to build. Rectangular tanks are more difficult to clean, specifically in the corners.

The volume of the clarifier tanks was calculated from equation (4):

$$\begin{aligned}
 V_{TOT} &= V_{frustum} + V_{cylinder} \\
 &= \frac{1}{3} \pi h_{cone} \left[\left(\frac{d_{top}}{2} \right)^2 + \frac{d_{top}}{2} \times \frac{d_{bot}}{2} + \left(\frac{d_{bot}}{2} \right)^2 \right] + \pi h_{cylinder} \left(\frac{d_{top}}{2} \right)^2 \dots\dots\dots(4)
 \end{aligned}$$

Where V_{TOT} is the total volume of the clarifier tank, d_{top} and d_{bot} are the upper and lower diameters of the frustum respectively and h_{cone} and $h_{cylinder}$ are the respective heights of the conic and the cylindrical sections of each clarifier vessel as illustrated in figure 1.

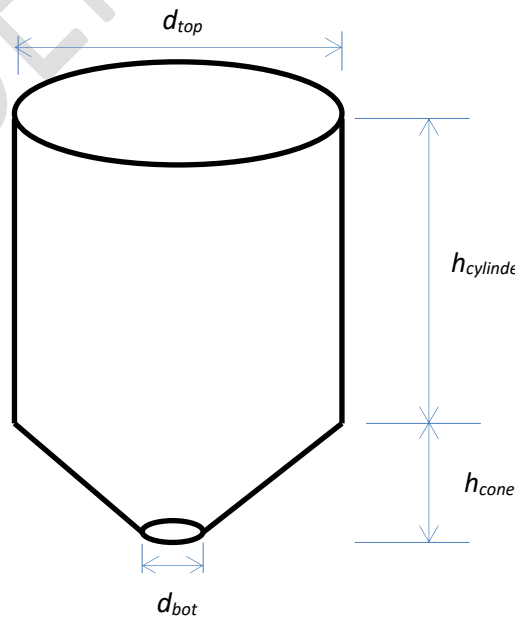

Figure 1: Clarifier tanks dimensions

The frame is the main support to which other parts of the clarifier are anchored. It was made using 45 x 45 x 4mm thick mild steel angle iron. Mild steel was chosen based on its moderate strength and good weldability.

A line drawing of the envisaged clarifier was then realized using AUTOCAD design software.

Operation of the Unit – The Clarification Process

The clarifier unit operates on the principle of the difference in the density (or specific gravity) of water and palm oil. Water was electrically heated and held in the hot water reservoir and the primary clarifier tank was 25% filled with water and heated to about 100°C. The press liquor to be clarified was then introduced into the primary clarifier through its hopper. The mixture was then heated for 10 – 15 minutes before letting hot water from the hot water reservoir into the primary clarifier tank. This forced the oil which by now floats on top of water, sludge, non-oily solids (NOS) and other debris in the primary clarifier to flow into the secondary clarifier tank through the orifice provided. The content of the secondary clarifier tank was again heated for 3 – 5 minutes by introducing hot water from the hot water reservoir. This led to an overflow of oil through the secondary tank orifice into the dehydrator tank where traces of moisture in the oil were eliminated by light heating. The clarified palm oil was then collected through the dehydrator outlet. The sludge that accumulates in the primary and secondary clarifier tanks was eliminated through their respective drain pipes. The temperatures of the various tanks were maintained at specific values and monitored on the control panel and the level gauges guided the operator during oil flow from one tank to the other.

Evaluation Procedure

The performance of the clarifier unit was evaluated at Tanda oil mill Bambui; an emerging township in northwestern Cameroon. The locality is the headquarters of Tubah sub-division in the North West Region of Cameroon. It lies on latitudes 6°3'0"N, 10°14'0"E. Press liquor emanating from a mechanical single screw palm oil press was used for the evaluation. The volume of the press liquor to be processed was measured and after clarification the volume of the clarified oil (oil recovered) was equally measured using a graduated plastic bucket and a 1000 ml graduated cylinder. The clarifier unit evaluation was carried out at various temperatures ranging between 80 and 90° C and at three different oil to water ratios. Statistical analysis was carried out using descriptive statistics.

Clarifier Unit Performance Evaluation

The performance of the unit was measured in terms of its throughput, oil extraction rate and clarification efficiency.

Throughput, C

It is a measure of the quantity of palm oil the unit can clarify per unit time (Godjo, 2016; Salawu *et al.*, 2015). It was calculated using equation (5).

$$C = \frac{\text{vol. of press liquor}}{\text{clarification time}} \times 100 \dots \dots \dots (5)$$

Oil Extraction Rate, OER

This is a measure of the quantity of oil extracted (in kg) compared to the total quantity of extractable oil in the press liquor. It was calculated using equation (6) (Godjo, 2016).

$$OER = \frac{\text{vol. of oil recovered}}{\text{vol. of press liquor}} \times 100 \dots \dots \dots (6)$$

Clarifier Efficiency, η_c

η_c gives an idea of the effectiveness of the clarifier (Salawu *et al.*, 2015). It is a measure of the quantity of palm oil contained in the press liquor that was extracted as clarified palm oil by the clarification unit. It was calculated using equation (7) (Godjo, 2016; Salawu *et al.*, 2015).

$$\eta_c = \frac{\text{vol. of oil recovered}}{\text{Theoretical vol. of oil in press liquor processed}} \times 100 \dots \dots \dots (7)$$

The theoretical volume of oil in press liquor was taken to be the percentage oil content of the fresh fruit bunches.

Economic Evaluation

The economic evaluation measures the value for money and attempts to determine whether this project provides an acceptable level of economic benefit to the local farmers. Here the evaluation concentrated on direct spending. This will provide small scale farmers with information about the opportunity cost of the decision to acquire the proposed clarifier or not.

Capital Cost Estimate

The capital cost for the incorporation of this model clarifier in an artisanal palm oil mill can be estimated using inside battery limits (ISBL) and outside battery limits (OSBL) costs (Vasalos *et al.*, 2016). ISBL investment concerns the primary equipment needed for the process and Vasalos *et al.*, (2016) proposes a simplified ISBL approach which has been used in this project and in line with this approach, estimates as per order of magnitude can be obtained by use of equation (8).

$$x_2 = x_1 \left(\frac{y_2}{y_1} \right)^n \dots \dots \dots (8)$$

Here x_2 is the estimated cost of the small scale processing unit to be established; x_1 is the cost of the prototype unit; y_2 is the desired capacity of the new unit; y_1 is the capacity of the prototype and n is the scale up exponent, which ranges between 0.6 and 0.8 depending on the equipment.

RESULTS AND DISCUSSION

The Designed Clarifier

The design of the clarifier unit is shown in *Figure 2* while a picture of the constructed equipment is shown in *Figure 3*. It consists of a 13.5 l hot water reservoir (1), a cylindrically shaped primary (2) and secondary (3) clarification tanks with conic bottoms, and an oil dehydrator (6) of volume 4 l; all made of 3mm thick food grade stainless steel plates. These tanks are mounted on a frame made from mild steel channel of dimensions 45 x 80 x 45 mm. All four tanks of the unit are provided with 400W heating coils and temperature sensors to maintain the temperature of their content at specific values; and both clarification tanks are provided with gauges (7) in order to monitor the level of fluid during clarification. The contents of the tanks can be drained through drainpipes provided at the bottom. The entire unit is controlled from an electric control panel (5).

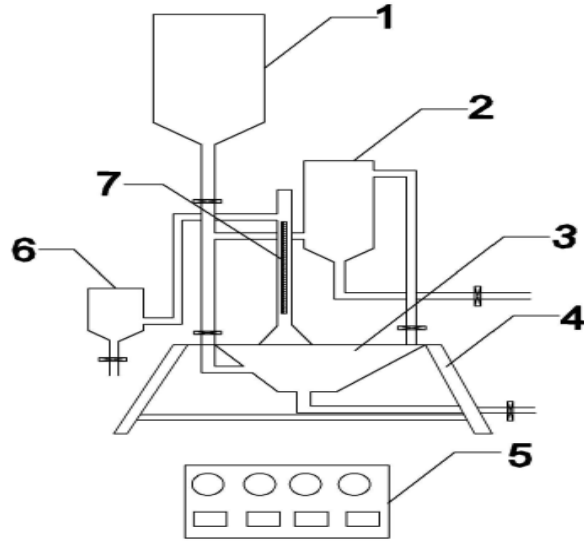

Figure 2: Line drawing of the clarifier unit that was developed

Legend: 1 – Hot water reservoir, 2 – Primary clarifier tank, 3 – Secondary clarifier tank, 4 – Frame, 5 – Control Panel, 6 – Dehydrator, 7 - Level gauge

Figure 3 shows the prototype that was constructed and later used for performance evaluation.

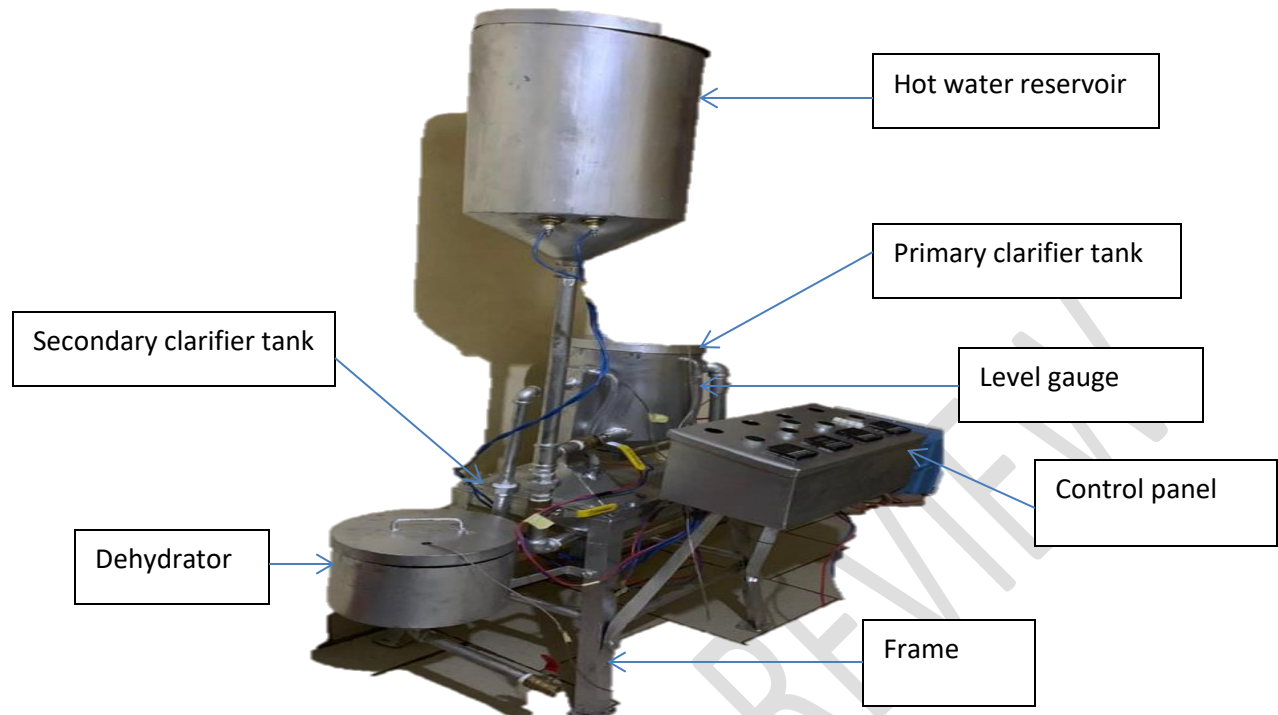

Figure 3: The developed prototype of the clarifier unit.

Performance Evaluation of the Clarifier

As earlier mentioned, throughput, oil extraction rate and clarifier efficiency were used to evaluate the performance of the clarifier as a function of temperature and oil-to-water dilution (mole) ratio. These parameter effects are described in sections 4.2.1-4.2.3.

Throughput

Figure 4 shows the effect of temperature on throughput at different mole ratios. In a general manner, throughput ranged from 0.73 to about 1L/min. Ahouansou *et al.*, (2018) reported throughput values of 0.43L/min for artisanal clarifiers which were lower compared to those reported in this work. The same author equally reports higher throughput values (3.90L/min) for semi-artisanal clarifiers. It can be observed from the figure that at all temperatures, the

throughput of the clarification process increased significantly with the mole ratio. An Increase in throughput with mole ratio can be attributed to a change in the viscosity of the press slurry to be clarified. An increase in water to oil ratio increases the quantity of oil in the mixture without a corresponding increase of the unwanted material. With a high viscosity less oil is dissolved in the sludge hence more oil is retained which is reflected in the increased through put.

No significant differences were observed in the throughputs as a function of temperature at all mole ratios.

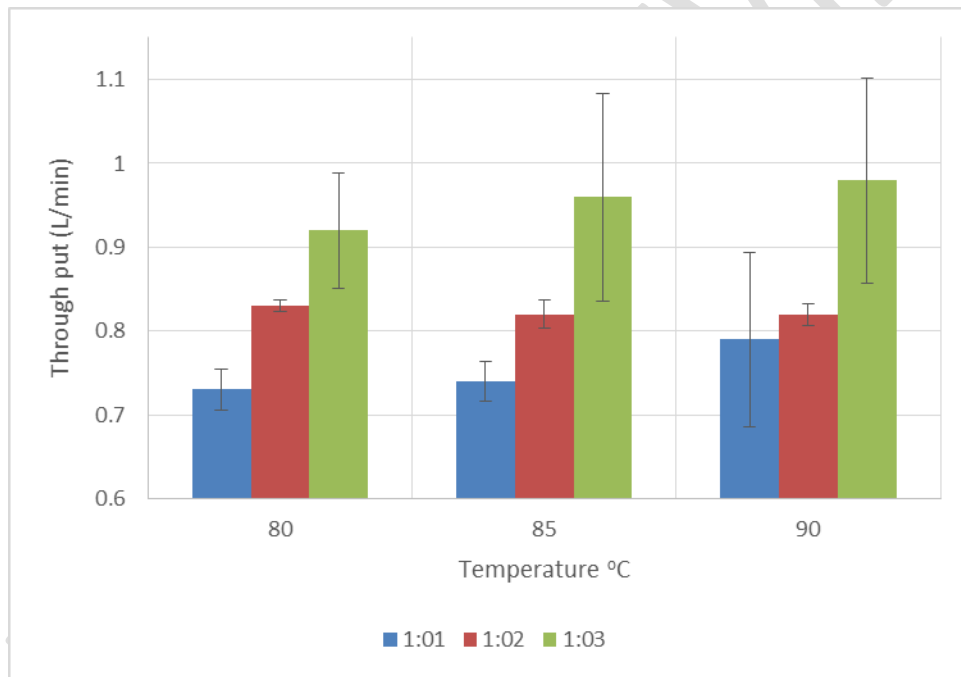

Figure 4: The effect of temperature on throughput at different mole ratios

Oil extraction rate (OER)

The effect of temperature on oil extraction rate at different mole ratios is captured in Figure 5. Generally OER ranged from about 13.3% for dilution ratio of 1:1 and a temperature of 80°C; to 16.3% for a 1:2 oil to water dilution ratio at 85°C. On the other hand, for a given mole ratio

we observed a decrease in extraction rate as clarification temperature increases from 85°C to 90°C. Between 80°C and 90°C, the best evolution for OER is obtained for the 1:2 mole ratio. As mole ratio increases to 1:3, the OER is seen to drop for the same clarification temperature. This is similar to the observations of Tah *et al.*, (2024) who reported consistently lower oil clarification yields at 90°C compared to yields at 80°C for different mole ratios. OER was seen to improve with dilution ratio increase for a given temperature. This is logical because as water quantity increases in the mixture the dissolution of impurities is enhanced and this implies a better oil/water/impurity separation and thus improvement in OER. The inverse relationship between extraction rate and temperature is due to the fact that oil is more soluble in water of a higher temperature. Thus at 90°C, more oil is dissolved in water and drained out with the sludge from the clarifier. We had earlier reported similar observation in a laboratory batch system (Tah *et al.*, 2024).

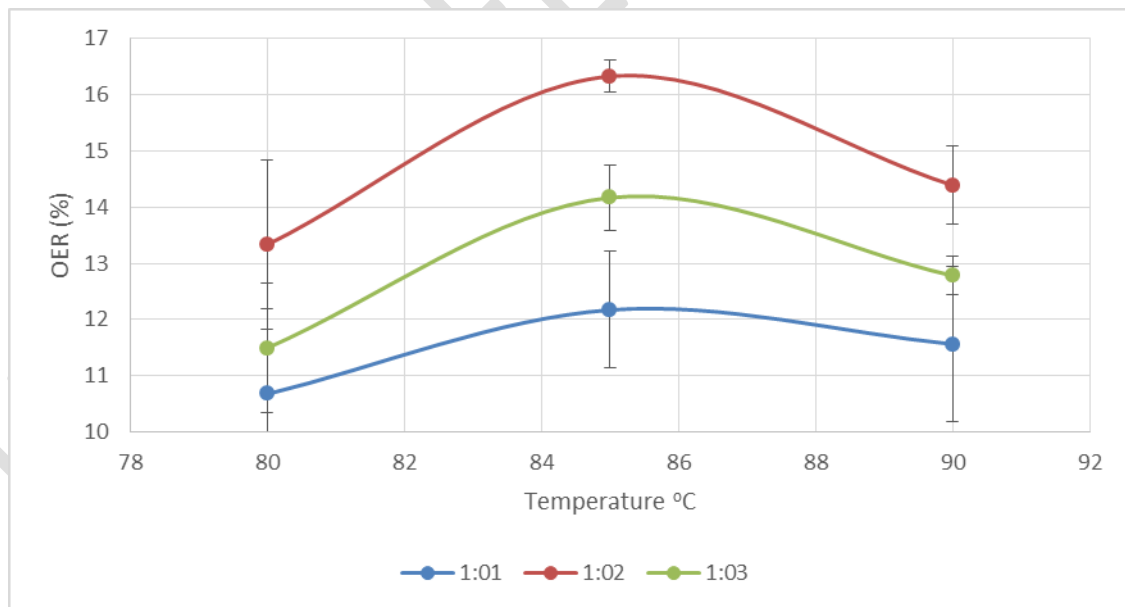

Figure 5: The effect of temperature on oil extraction rate at different mole ratios

Clarifier efficiency

The variation of clarification efficiency with temperature was observed to follow a similar pattern as the OER (see *Figure 6*). Clarifier efficiency values ranged from 48% to a peak value of 74.5% at 85°C when the dilution ratio was 1:2. Efficiencies at dilution ratio 1: 2 were observed to be higher than for dilution ratio 1:3. This is similar to the results obtained by Salawu *et al.*, (2015) for the extraction of jatropha curcas seeds. A decline in clarifier efficiency as dilution ratio increases can be explained by the fact that practically there will always be some oil losses.

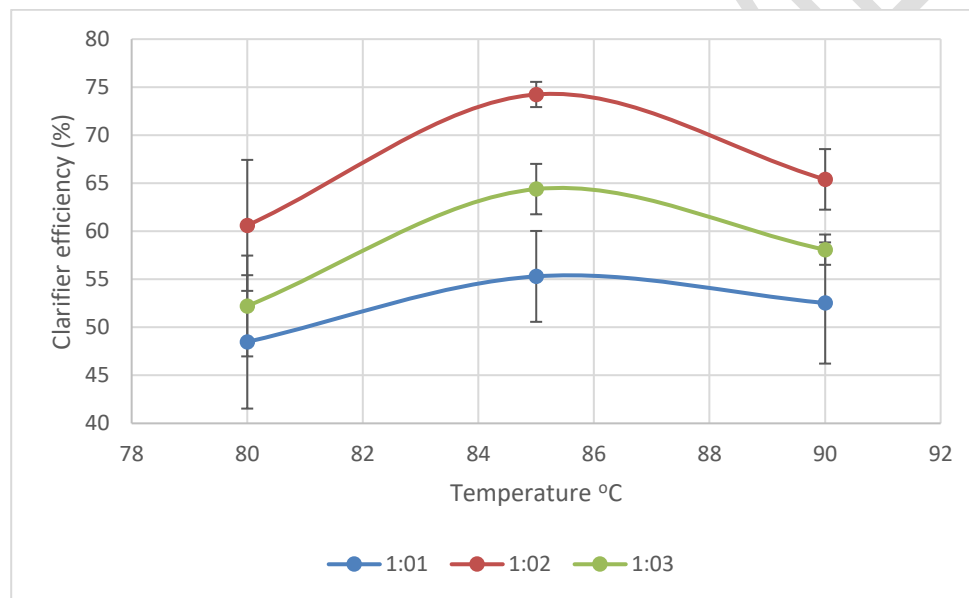

Figure 6: The variation of clarification efficiency with temperature

Cost Estimation of the Designed Clarifier

The project cost is estimated based on the equipment listed in *Table 1* and the accompanying prices are quotes from personal interviews of popular palm oil process equipment manufacturers in Douala, Cameroon. It is observed from *Table 1* that for existing POMs, with less than a

million FCFA the new clarifier unit can be acquired to replace metallic drums and thus attain better profit margins.

TABLE 1: EQUIPMENT LIST FOR A 500 KG/HR PALM FRUITS ARTISANAL MILL

Equipment	Unit	Capacity	Quotes from equipment manufacturers (FCFA)			Average cost (FCFA)
			(a)	(b)	(c)	
Sterilized fruit conveyor	kg/hr	500	700,000	550,000	600,000	616,667
Digester	m ³ /hr	2	1,500,000	1,200,000	1,400,000	1,366,667
Single screw press	kg/hr	500	2,200,000	2,500,000	1,900,000	2,200,000
Clarifier Unit	m ³ /hr	3	1,000,000	800,000	850,000	883,333
Oil transfer pump	l/hr	1000	650,000	550,000	550,000	583,333
Angle iron for platform	length	10	150,000	150,000	150,000	150,000
Checker plates for platform	Nos.	4	500,000	400,000	500,000	466,667
TOTAL						6,266,667

CONCLUSION

A cost-effective and efficient small-scale palm oil clarifier was successfully designed, developed and evaluated. This prototype is very suitable for small-scale processors because it is easy to operate and requires very minimal investment as it uses readily available materials.

The performance of this new equipment is satisfactory with an optimum clarifier efficiency of 74.24% at mole ratio 1:2 and clarification temperature of 85°C. Under these conditions an oil extraction rate of up to 16.33% was obtained. It is expected that upon incorporation into a small scale palm oil process line, it will go a long way to improve the oil extraction rate for small scale palm oil millers.

Disclaimer (Artificial intelligence)

Option 1:

Author(s) hereby declare that NO generative AI technologies such as Large Language Models (ChatGPT, COPILOT, etc.) and text-to-image generators have been used during the writing or editing of this manuscript.

Option 2:

Author(s) hereby declare that generative AI technologies such as Large Language Models, etc. have been used during the writing or editing of manuscripts. This explanation will include the name, version, model, and source of the generative AI technology and as well as all input prompts provided to the generative AI technology

Details of the AI usage are given below:

- 1.
- 2.
- 3.

REFERENCES

1. Ahouansou R.H., Agbobatinkpo P.B., Sossou C.H. and Sanya E.A. (2018). Analyse des performances techniques des clarificateurs et déshydrateurs d'huile de palme au Bénin. *Tropicultura*. 36(4); 773-785
2. Al-Zuhair S.A.S.(1998). The design of crude palm oil clarifier. Master of Science thesis. Universiti Putra Malaysia.
3. Chung A.Y.K (2006). Clarification tank simulation. Palm oil engineering bulletin no. 79. MPOB
4. Dick R.I. (1974): Folklore in design of final settling tanks. University of Delaware; Newark, Delaware 19711.
5. Ekka R and Sharma M. (2020). Case study on reducing food loss in palm oil in Cameroon. *Agribusiness Associates Inc.*

6. Godjo T. (2016). Development of an oil extraction machine for cashew nut shell. *IJET* – 2 2395-13036.
7. Hassan, M. A., Njeshu, G, Raji, A., Zhengwuvi, L and Salisu, J. (2016). Small-scale palm oil processing in west and central Africa: development and challenges. *JASES* 2 (5) 102 – 114.
8. Maire V., Lee A. (2019). OLAM Gabon operations: product loss in palm oil value chains: an FLW standard case study. Food loss + waste protocol. www.FLWProtocol.org.
9. Manaf F.Y.A and Chung A.Y.K (2018). Automatic crude oil dilution control with premium oil segregation using near infra-red (NIR) On-line system. *J. Oil Palm Res* 0012.
10. Nchanji Y. K., Tataw O, Nkongho R. N. and Levang P. (2013). Artisanal milling of palm oil in Cameroon. *Working Paper 128*. Bogor, Indonesia: CIFOR.
11. Njeshu, G.N., Ngwabie, N.M., Bup, D.N. and Tsamo, C. (2023). Techniques and technological aspects of palm oil (*Elaeis guineensis*) processing in Cameroon. *WJET*, 11, 756-769.
12. Nkongho R. N., Feintrenie L., and Levang P. (2014a). Strengths and weaknesses of the smallholder oil palm sector in Cameroon. OCL, 21(2) D208. *EDP Sciences*. DOI: 10.1051/ocl/2013043.
13. Nkongho RN, Feintrenie L and Levang P. (2014b). The non-industrial palm oil sector in Cameroon. *Working Paper 139*. Bogor, Indonesia: CIFOR.
14. Nkongho RN, Nchanji Y., Tataw O., and Levang P. (2014c). Less oil but more money! Artisanal palm oil milling in Cameroon. *AJAR* 9(20). 1586-1596.

15. Ordway E. M., Naylor R. L., Nkongho R. N., and Lambin E. F. (2017). Oil palm expansion in Cameroon: insights into sustainability opportunities and challenges in Africa. *Gloenvcha* 47; 190–200.
16. Rafflegeau S., Nanda D., Genot C (2018). Artisanal mills and local production of palm oil by smallholders. Achieving sustainable cultivation of oil palm Volume 2: Diseases, pests, quality and sustainability, Burleigh Dodds Science Publishing Limited, Burleigh Dodds *Series in Agricultural Science*, 978 1 78676 108 8. [ff10.19103/AS.2017.0018.36ff](https://doi.org/10.19103/AS.2017.0018.36ff). [ffhal-02791205](https://doi.org/10.19103/AS.2017.0018.36ff)
17. Rashidi A. E. (2020). How to increase the efficiency of palm oil. *Int Jour for Innov Res in Multidisciplinary Field* 6(9) 2455-0620.
18. Salawu A. T., Isiaka M., and Suleiman M. L. (2015). Development of an oil extraction machine for *Jatropha curcas* Seeds. *JSRR* 6(4): 313-328.
19. Tah E., Njeshu G.N., Bup D.N., Woumbo C., Mboukap A.N. and Womeni H. (2024). Batch system clarification of two varieties of palm oil: kinetics and thermodynamics. *J. Oil Palm Res.* DOI: <https://doi.org/10.21894/jopr.2024.0007>
20. Vasalos I. A., Lappas A. A., Kopalidou E. P. and Kalogiannis K. G. (2016). Biomass catalytic pyrolysis: process design and economic analysis. *WIREs Energy Environ*, 5:370–383. doi: 10.1002/wene.192
21. WEF (2005). *Clarifier Design: WEF manual of practice No. FD-8*. Second edition. McGraw-Hills, Alexandria, USA.
22. Yunus R. (2019). Long-term research grant scheme (LRGS) sharing the experience (2012 – 2017). *Universiti Putra Malaysia*.

23. Kavuma, A., & Barakagira, A. (2024). Effect of Effluents Produced from Palm oil Processing Industries on Fish Production around Bugala Island, Kalangala District, Uganda. *Asian Journal of Environment & Ecology*, 23(11), 1–14. <https://doi.org/10.9734/ajee/2024/v23i11617>

24.

UNDER PEER REVIEW