

## SIMULATION AND IMPLEMENTATION OF VEHICLE DRIVERS ALCOHOL AND TEMPERATURE MONITORING SYSTEM

### ABSTRACT

Drunk driving is one of the major cause of road accidents especially in Nigeria where there is no controls or checks to the level of alcohol content of drivers. In this study, a vehicle alcohol and temperature monitoring system was simulated and constructed using an Arduino Uno microcontroller ATmega328. The circuit was simulated in Proteus8.1 design suit comprising an alcohol sensor, contactless temperature sensor, motor/relay driver, ignition, 16x2 Liquid Crystal Display (LCD), and 5V DC power. The simulated circuit was constructed on a printed circuit board and tested for continuity and power 'ON'. An evaluation performance test was also carried out using 40 volunteers that have consumed varying amounts of alcohol content ranging from two to fifteen standard drink and their blood alcohol content (BAC) as well as body temperature were measured. The true positive, false positive, true negative and false negative were recorded. Results showed that the constructed device has sensitivity of 92% and specificity of 75% depicting that the system can correctly identify 92% presence of alcohol and 75% of alcohol absence with 90% accuracy. It however, failed to identify only 8% alcohol presence and 25% alcohol absence. The device if installed in a vehicle could be significantly useful in averting road accidents caused by drunk driving. Ensuring the public and commercial drivers have a clear understanding of the law and raising awareness of the impact drink drive has on road users is important to reducing its prevalence.

**Keywords:** Drunk driving; blood alcohol content; microcontroller; Proteus design suit; temperature monitoring; implementation.

### 1. Introduction

One of the serious societal health concerns is drunk driving, which leads to accident. Many have been disabled and lives wasted due to this reckless attitude of many drivers (Prathamesh et al. 2019). An accident is an unexpected action which occur in a particular situation or place (Sivakuma and Dhivya 2016). These days, road accident is a major challenge all over the world and they are mostly caused by drivers driving while being drunk. According to Prashant et al. (2014) with a few exceptions to mechanical, electrical faults and fatigue, most road mishaps are largely due to drunk driving and largely accounts for about one third of all road accidents. Report of World Health Organization (WHO) (2021) revealed that road accident is the leading killer of people aged between five to twenty-nine years across the world. It addition, drunk driving is a major factor for the rise of accidents leading to deaths on roads (Prathamesh et al. 2019). Statistics have shown that approximately 700, 000 road accident occur in the world per annum, with 10% of this occurring in India having overtaken China (Prashant et al. 2014). Globally, about 1.35 million people die each year as a result of road traffic crashes, and between 20 and 50 million more people suffer non-fatal injuries, with many incurring a disability as a result of their injury. Also, 93% of the world's fatalities on the roads occur in low- and middle-income countries, even though these countries have approximately 60% of the world's vehicles (WHO 2021;Adriazola-Steil et al. 2019). According to WHO (2021) road traffic crashes have cost most countries 3% of their gross domestic product.

High level of alcohol in the body can affects peoples' sense of judgments which could endanger their lives and that of other road users. In addition, since there is no any special device in our vehicles to determine the level of alcohol consumption of the driver, it becomes very difficult for security operatives and road marshals to handle such problems. In the case of Nigeria effective monitoring of road users is a major concern asroad accident is in the increase with an alarming rate and alcohol is reported to be a major contributor to road accident throughout the country (Ogazi and Edison 2012;Ventures Africa 2021). It is common to see drivers consuming alcohol at stopovers

during long distance journey in the country and today, alcohol-related traffic accidents represent a very real threat to the social and economic progress of Nigeria (Ventures Africa 2021;Enimola 2019). Ozor (2017) reported that the Federal Road Safety Commission (FRSC) had said 90% of road accidents in the country was as a result of alcoholic drinks, hard drugs among others factors. Nigerian Tribune (2022), added that these crashes are linked to speeding, route violation, mechanical defect, drunk driving and dangerous driving. Welcome and Pereverzev (2010) had earlier observed that approximately 50% of road traffic accidents on Nigerian roads are linked with alcohol use. According to Nigerian Tribune (2022) over 106,256 Nigerians were involved in road traffic crashes between January 2019 and December 2021. Out of this figure, 14,773 people died in the 31,116 crashes recorded within the period and about 91,483 people were said to have sustained various degrees of injury. Within this period, the year 2021 witnessed the highest number of cases.

Statistics reported by Sasu (2022) claimed that over 11,520 road traffic casualties were recorded in Nigeria in 2020 with 9,702 injured and 1,818 death cases, while in 2021, over 11,823 road traffic casualties were recorded with 10,171 injured and 1,652 death cases. The National Bureau of Statistics (NBS) reported a total of 2,927 males died in road traffic crashes within fourth quarter of 2020 and the second quarter of 2021 (Guardian Nigeria 2022). Some of the preventive measures put in place by Federal Government of Nigeria to control this situation are enhanced visibility; broadened, strengthened and sustained stakeholders' engagement and collaboration, improved personnel capacity in road safety management, effective patrol operations, and widened public enlightenment campaigns (Nigerian Tribune 2022). However, despite the high levels of alcohol consumption among the driving population in Nigeria, there has been little effort by the government to regulate and introduce alcohol policy to control drink driving in the country (Enimola 2019), no a standard drink definition (Odeigah et al. 2022), and no low-risk drinking guidelines (LRDG) (Morojele et al. 2021; WHO 2018). Also, drivers hardly obey the law on alcohol consumption and driving despite the Drive Alcohol-Free (DAF) campaign that has been running since November 2014 and the blood alcohol concentration (BAC) limit law of 0.05g/100mL, because enforcement of the law is weak and alcohol testing equipment is unavailable (Ogazi and Edison 2012; Enimola 2019).

In view of the above, this study simulates and construct a vehicle driver's alcohol and temperature sensing alert with engine locking system to mitigate these challenges. The device if installed in vehicles, will enable the engine of the vehicle not to start at all or to stop (if the engine was running) as the microcontroller sensed alcohol presence at or beyond 4.5mg/ml. In addition, some individuals that can consume a lot of Alcohol may have other infection or sickness that needs clinical attention but may not show remarkable effect on their body due to Alcohol suppression, rather, their temperature level may be elevated and if there is a device to monitor such changes, then the situation can be arrested. Therefore, this study will also include a temperature monitoring device alongside the Alcohol monitoring component so as to mitigate this effect.

## **2. Materials and method**

### **2.1 Materials**

The materials and their specification that were used for the implementation of a vehicle driver's alcohol and temperature monitoring system includes microcontroller ATmega328, MQ-3 alcohol gas sensor, contactless temperature sensor, SIM800L (Subscriber Identity Module) GSM (Global System for Mobile) module, buzzer, 16 x 2 LCD (Liquid Crystal Display), buck converter, 12V/2Amp adaptor, PCB (Printed Circuit Board), Bread board.

### **2.2 Methods**

The methods for implementation of the vehicle driver's alcohol and temperature monitoring system was carried out in three (3) parts to include software design method, hardware construction method and circuit analysis (testing) method. The process was carried out according to the block diagram shown in Figure 1. The stages in the implementation includes the alcohol sensor unit, contactless temperature sensor unit, ignition unit, LCD unit, SMS (Short Message Service) module, relay motor unit, buzzer unit, Arduino Uno unit and power supply unit.

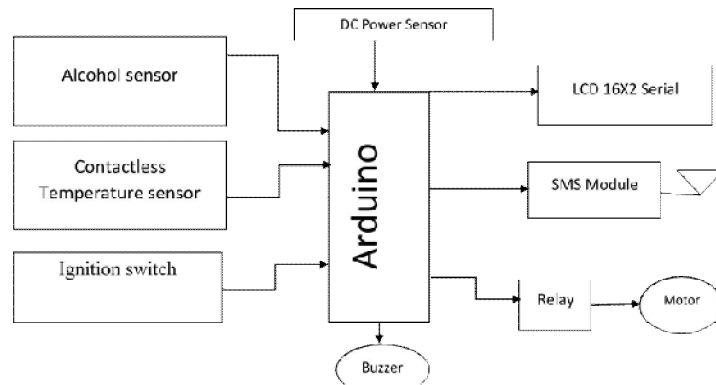

**Fig. 1** Block diagram of the proposed alcohol and temperature monitoring system

### Stage 1: The Alcohol Sensor/ Module Circuit

The alcohol sensor module makes use of an Alcohol Gas Sensor MQ-3. It can detect the presence of alcohol gas at the concentration of 0.5mg/L to 10 Mg/L using a low cost semiconductor sensor. The sensitive material used for this sensor is Tin (IV) Oxide (SnO<sub>2</sub>), whose conductivity is lower in clean air. Its conductivity increases as the concentration of alcohol gases increases. It has high sensitivity to alcohol and has a good resistance to disturbances due to smoke, vapor and gasoline. This module provides both digital and analog outputs. MQ-3 alcohol sensor module was chosen because it can be easily interfaced with Microcontrollers, Arduino Boards and Raspberry Pi etc. This alcohol sensor is suitable for detecting alcohol concentration on your breath, just like your common Breathalyzer. It has a high sensitivity and fast response time. The sensor provides an analog resistive output based on alcohol concentration. The alcohol sensor unit is shown in Figure 2a while Figure 2b shows the module.

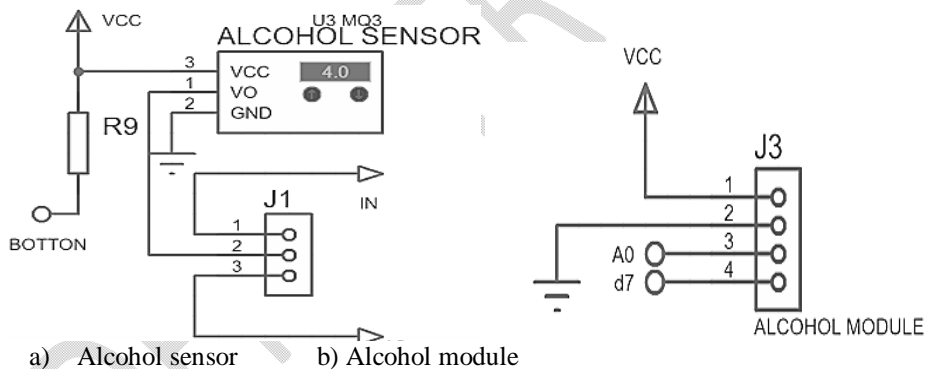

**Fig. 2** Alcohol Sensor and Module (Jha 2016)

### Stage 2: The Contactless Temperature Unit

Contactless Infrared (IR) Temperature Sensor measures the surface temperature of an object depending on the emitted IR waves of the target without touching it and also measures the average temperature over an area. It is a Contactless, high precision, high resolution and a fast response sensor. In this study the MLX90614 Contactless Infrared (IR) Temperature Sensor was used to measure the temperature of drunk drivers. The specifications of the sensor according to Waveshare (2023) shows that it works on power: 3.3V ~ 5V with measuring range (area): 40°C ~ 85°C and measuring range (object): -70°C ~ 380°C. It has resolution: 0.02°C, precision: ±0.5°C (0~50°C) and field of view (FOV): 35°. The dimension measures 28mm x 16mm with a mounting holes size: 2.0mm. Figure 3 shows the circuit diagram of the temperature sensor unit.



**Fig. 3** Contactless Infrared (IR) Temperature Sensor Unit (Waveshare 2023)

### Stage 3: The Ignition Switch Unit

An ignition switch, starter switch or start switch is a switch in the control system of a motor vehicle that activates the main electrical systems for the vehicle, including "accessories" (radio, power windows, etc.). In vehicles powered by internal combustion engines, the switch provides power to the starter solenoid and the ignition system components (including the engine control unit and ignition coil), and is frequently combined with the starter switch which activates the starter motor. Thus mechanical switches remain common in modern vehicles, further combination with an immobilizer can only activate the switch functions when a transponder signal in the key is detected. However, many new vehicles have been equipped with so-called "keyless" systems, which replace the key switch with a push button that also requires a transponder signal. The ignition locking system may be sometimes bypassed by disconnecting the wiring to the switch and manipulating it directly; this is known as hotwiring.

### Stage 4: The LCD Unit

An LCD (Liquid Crystal Display) screen is an electronic display module and has a wide range of applications. A 16x2 LCD display is very basic module and is very commonly used in various devices and circuits. It can display 16 characters per line and there are 2 such lines. Each character is displayed in 5x7 pixel matrix. The 16 x 2 intelligent alphanumeric dot matrix display is capable of displaying 224 different characters and symbols. This LCD has two registers, namely, Command and Data.

Command register stores various commands given to the LCD display while data register stores data to be displayed. The process of controlling the display involves putting the data that form the image of what you want to display into the data registers, then putting instructions in the instruction register. In Arduino project, Liquid Crystal Library simplifies this, hence, there is usually no need to know the low-level instructions. However, the contrast of the display can be adjusted by adjusting the potentiometer to be connected across VEE pin. Figure 4 shows the 16x2 LCD unit.

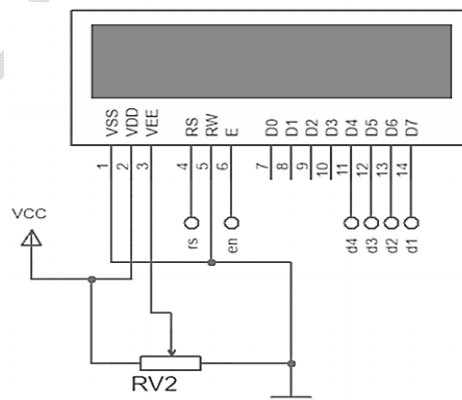

**Fig. 4** LCD1 LMO16L Unit

### Stage 5: The SMS Module

SIM800L GSM/GPRS module is a miniature GSM modem, which can be integrated into a great number of IoT (Internet of Things) projects. This module can accomplish almost anything a normal cell phone can accomplish;

SMS text messages, Make or receive phone calls, connecting to internet through GPRS (General Packet Radio Service), TCP/IP (Transmission Control Protocol/ Internet Protocol), and more. The module also supports quad-band GSM/GPRS network, meaning it works pretty much anywhere in the world. The heart of the module contains SIM800L GSM cellular chip. The operating voltage of the chip is from 3.4V to 4.4V, which makes it ideal for direct LiPo (Lithium Polymer) battery supply, this makes it a good choice for embedding into projects without a lot of space.

All the necessary data pins of SIM800L GSM chip are broken out to a 0.1" pitch headers which includes pins required for communication with a microcontroller over Universal Asynchronous Receiver/Transmitter (UART). The module supports baud rate from 1200bps to 115200bps with Auto-Baud detection. The module needs an external antenna to connect to a network. It usually come with a Helical Antenna and solders directly to NET pin on PCB (Printable Circuit Board). The board also has a UFL connector facility should the antenna needed to be kept away from the board. Figure 5 shows the circuit diagram of SIM 800L unit.

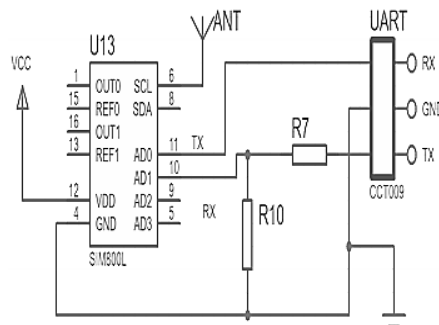

**Fig. 5** SIM 800L unit

### Stage 6: The Relay Output Driver and Buzzer Unit

Relays are switches that open and close circuits electromechanically or electronically. Relays are generally used to switch smaller currents in a control circuit and do not usually control power consuming devices except for small motors and Solenoids that draw low amps. A buzzer is an audio signaling device, which may be mechanical, electromechanical or piezoelectric. Typical uses of buzzers and beepers include alarm devices, timers, confirmation of user inputs such as a mouse click or key stroke. The circuit diagram of the relay/motor output driver is shown in Figure 6a, while a simple buzzer circuit unit is shown in Figure 6b.

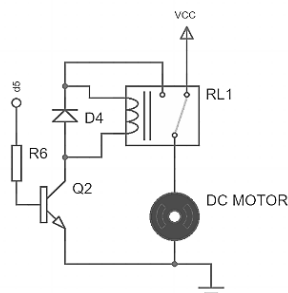

a) Relay output driver

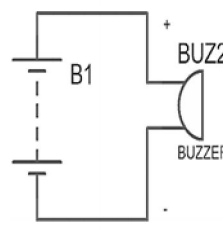

b) Buzzer

**Fig. 6** The relay output driver and buzzer unit

### Stage 7: The Arduino Uno Microcontroller Unit

The Arduino is an open source platform used for building electronics projects, it consists of a physical programmable circuit board (often referred to as a microcontroller) and a piece of software, or IDE (Integrated Development Environment) that runs on your computer, used to write and upload computer code to the physical board. The Arduino IDE uses a simplified version C++, making it easier to learn the program. Arduino Ide Tool:

Covers virtually everything; it is the finest choice for learners; with the use of an ATmega328 microcontroller with 14 input pins, Arduino Uno is one of the greatest common progress boards in automation and electronics. Steps for Using Arduino IDE include the Arduino microcontroller which comes in different types, the commonly used is the Arduino Uno (Ojha et al. 2016). In this work, the Arduino Uno ATmega328 was used. Figure 7 shows the circuit diagram of the microcontroller unit.

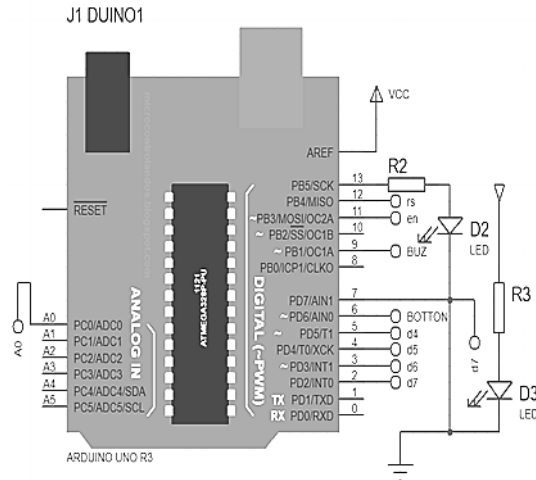

**Fig. 7** Microcontroller unit

### Stage 8: The DC Power Supply unit

Power supply describes the circuit after which a selected dc voltage to operate the additional circuits are obtained. The voltage from the main source is 220V AC, though some sections of the circuit will need 5V DC. Therefore, a step-down transformer is required to get 12V AC from 220V which can be rectified to 12V DC. The rectified voltage still contains some ripples. The ripples are removed to realize a smoothed signal using DC power filter circuits. The power supply is intended to convert high voltage AC mains to the required low voltage supply for electronic circuits and any other additional circuits. This is used to power the relay/motor unit with 12V but regulated to 5V to power the microcontroller (Eugene 2018). Figure 8 shows the circuit diagram of regulated power supply used in this study.

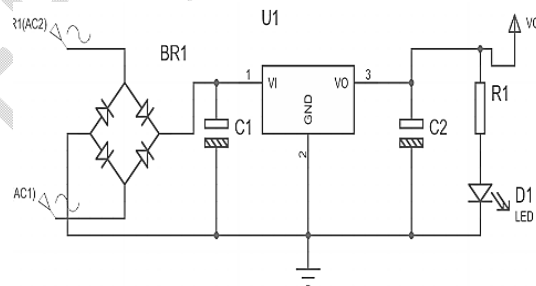

**Fig.8** Regulated power supply unit

### 2.2.1 Software Design Method

The software design for the system includes simulation, algorithm, flowchart, and choice of programming language.

#### 2.2.1.1 Simulation Method

The simulation of the vehicle driver's alcohol and temperature monitoring system was carried out in stages according to the block diagram presented in Figure 1. The circuit was simulated using Proteus ver8.0 software.

### 2.2.1.2 The Flow Chart

The flow chart for the vehicle alcohol and temperature monitoring system is as shown in Figure 9.

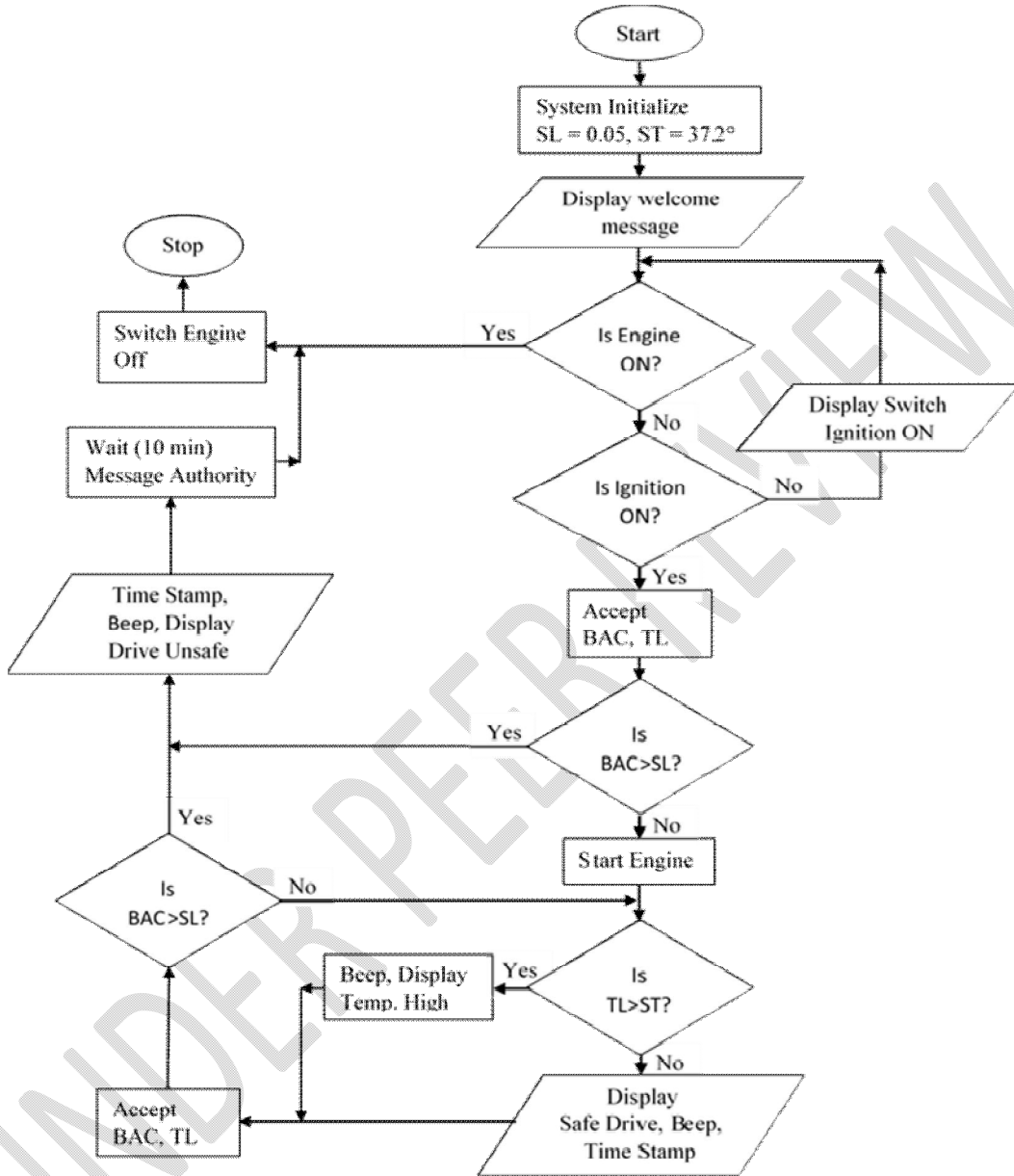

Fig. 9 Flowchart for the proposed alcohol and temperature monitoring system (BAL = Blood Alcohol Content, SL = Significant Level (0.05), TL = Temperature Level, ST = Significant Temperature (37.2°C))

### 2.2.1.3 The Algorithm

The algorithm that explains the flow chart for the vehicle alcohol and temperature monitoring system is presented as follows:

/\*\* Blood Alcohol Level (BAL); SL → Sig. level (0.05)

/\*\* Temperature Level (TL); ST → Sig. Temp (37.2°)

Set SL = 0.05, ST = 37.2°

```

    Print "welcome message".
20 initialize BAL, TL
    If Engine is 'ON' Go To Stop
    If ignition is 'OFF' Go To 20
        Read the sensors reading BAL, TL [Accept BAL, TL]
    If BAL > SL Go To Stop
        Start Engine
Loop If TL > ST Display Temp. is high
    Else
        Display Safe Drive, Beep, Timestamp ().
    Accept BAL, TL.
    If BAL > SL Go To Stop1.
    Else
        Go To Loop
Stop1
    Timestamp ()
    Beep
    Display Drive Unsafe, Stop.
    Wait (10 mins)
    Send Message to Authority.
Stop
    Turn Off Engine
End

```

#### 2.2.1.4 Choice of Programming Language

The choice of programming language must be available on a wide set of platforms, the implementation of the chosen language must be widely accepted and available, compilers producing highly optimized codes are required. This may be Java, C, Embedded C and C++ etc. (Agarwal 2015). In this work, the choice of programming language for the microcontroller is C language. This is widely used in programming language for embedded microcontrollers. C language is also used mainly to implement those portion of the code where very timing accuracy, code size efficiency are key requirements.

#### 2.2.2 Hardware Construction Method

The circuit construction was carried out in stages according to the block diagram shown in Figure 1. The components were first assembled on electronics breadboard to ensure proper terminal connections and then transferred on to a PCB and soldered using the soldering iron and MBO Imm wire lead solder, +183°C melting point. The microcontroller and the Arduino Uno exists as a component while the temperature sensor, the alcohol

sensor, the LCD, the relay/motor unit and every other component in the system were interfaced with the microcontroller and Arduino board. However, too much Lead was avoided to prevent clumsiness and bridging of the component to each another.

### 2.2.3 Circuit Testing Method

Components testing was carried out before fixing them on the Printed Circuit Board. Also Continuity test and Power ON test were carried out during construction to ensure proper functioning of the circuit and to ensure that no components in the circuit undergo heating when the device is in use and also to avoid loading and impedance mismatch of one stage and another. Finally, the constructed prototype was tested and the performance evaluation test was carried out for specificity, sensitivity and accuracy tests.

#### 2.2.3.1 Continuity Test

This test is performed just after the hardware soldering and configuration has been completed. The test is aimed at finding any electrical open paths in the circuit after the soldering. Many times, the electrical continuity in the circuit is lost due to improper soldering, wrong and rough handling of the PCB, improper usage of the soldering iron, component failures and presence of bugs in the circuit. The continuity test was carried out to make sure no cable or line jammed and all lines have free flow of electrons. It helps the researcher to check and see if current flows in the constructed electric circuit or the lines are continuous. This is usually achieved by placing a small wire in series with an LED (Light Emitting Diode) or noise-producing component such as a piezoelectric speaker across the chosen path. If electron flow is inhibited by broken conductors, damaged components, or excessive resistance, the circuit is "open". The test can be performed by using a multi meters which measure current and specialized continuity testers which are cheaper and more basic devices, or generally with a simple light bulb that lights up when current flows or even a piezo electric speaker. We used a multi meter to perform this test in this study.

#### 2.2.3.2 Power ON Test

This test is carried out to ascertain whether the voltage at the different terminals is according to the requirement or not. It was carried out without microcontroller to protect the microcontroller from damage by any excessive voltage and possible heat (Jha 2016). A multi meter was put in voltage mode, initially; the output of the power supply was checked to ascertain the present of 12V dc, and this voltage was applied to the voltage regulator which serves as its input. The input and output to the voltage regulator were checked to confirm voltages 12Vdc input and 5Vdc output. This 5Vdc output was used to operate the microcontroller via 40th pin, the voltage level at 40th pin and the other terminals were also checked, to ensure that they met specified requirement since same 5Vdc (VCC) was used for both the microcontroller and the sensors.

### 2.2.4 Blood Alcohol Content Calculation Method

The Blood Alcohol Content in this study was calculated following the Widmax formula as explained by Ziats (2021) as follows:

$$BAC = \left[ \frac{\text{Alcohol consumed in grams}}{(\text{Body weight in grams} \times r)} \right] \times 100 \quad (1)$$

Where "r" is the gender constant: r = 0.55 for females and 0.68 for males.

#### 2.2.4.1 Alcohol Consumed in Grams Calculation Method

Grams of alcohol consumed is equivalent to counting how many drinks have been consumed in a given period based on a standard drink size and alcohol content, rather than the number of glasses, bottles, cans, sachets, etc. consumed (Ziats 2021; Odeigah et al. 2022). This is because the volume and content of drinks vary widely and standard drink size varies from country to country and from drink to drink (Ziats 2021). Even though in Nigeria alcohol is a common feature in social ceremonies, with heavy episodic drinking (HED) as the preferred pattern of consumption, according to Odeigah et al. (2022), there is no standard drink definition in Nigeria. Therefore, we adapt the United States standard drink size. According to Ziats (2021), standard drink size of an 80-proof version of a distilled spirit

such as gin or whiskey is approximately 1.5 ounces which is about 40% alcohol volume. That of a beer with a 5% volume of alcohol is 12 ounces, while that of a wine with a 12% volume of alcohol is 5 ounces. A standard drink contains approximately 14 grams of alcohol. Therefore, the alcohol dose in grams, that is, the amount of alcohol consumed is calculated as:

$$\text{Grams of alcohol consumed} = \text{number of standard drinks consumed} \times 14 \quad (2)$$

Or

$$\text{Grams of alcohol consumed} = (\text{Volume of drinks}) \times (\text{AC of drinks}) \times 0.789 \quad (3)$$

If there is different alcohol content in a standard drink, the number of standard drinks consumed is multiplied by that alcohol content in grams.

#### 2.2.4.2 Body Weight in Grams Calculation Method

The body weight in pounds is converted to grams following the Metric Conversions (2020) as follows:

$$\text{Body weight in grams} = \text{Body weight in pounds} / 0.0022046 \quad (4)$$

Or

$$\text{Body weight in grams} = \text{Body weight in pounds} \times 454 \quad (5)$$

#### 2.2.4.3 The Raw Number Calculation Method

The body weight in grams is then obtained and multiplied by the gender constant. Then divide the alcohol consumed in grams by (body weight in grams x gender constant.) to obtain a raw number based on the alcohol content in the body.

$$\text{Raw number} = \frac{\text{Alcohol consumed in grams}}{\text{Body weight in grams} \times \text{gender constant}} \quad (6)$$

#### 2.2.4.4 Accounting for Elapsed Time and Body Metabolism

However, if a person have been drinking over a period of time, there is need to account for the elapsed time and the amount of alcohol that the body has already metabolized by the time you calculate the BAC. To do this, we multiply the raw number by 100 to get the BAC as a percentage and then use the formula explained by Ziats (2021) as follows:

$$\text{Approximate BAC} = \text{BAC as a percentage} - (\text{elapsed time in hours} \times 0.015) \quad (7)$$

#### 2.2.5 Performance Evaluation Test

This test was carried out to evaluate the prototype circuit functionality to access how successful is the device performance. The response of the system should be in line with the design. Evaluation test was achieved using the 'Gold Standard' relation and the following measurements were carried out:

**True Positive (TP):** Number of times alcohol level was high and correctly detected by the system.

**False Negative (FN):** Number of times alcohol level was high and wrongly undetected by the system.

**True Negative (TN):** Number of times alcohol level was low and correctly undetected by the system.

**False Positive (FP):** Number of times alcohol level was low and wrongly detected by the system.

The values obtained from the outcome of the test was used to calculate the specificity, sensitivity and accuracy of the device.

**Specificity ( $S_p$ ):** This is the ability of the system to correctly identify low or no alcohol around the unit and can be calculated as follows:

$$S_p = \frac{TN}{TN+FP} \times 100 \quad (8)$$

**Sensitivity ( $S_e$ ):** This is the ability of the system to correctly detect alcohol between 40cm – 90cm away from the unit and can be calculated as follows:

$$S_e = \frac{TP}{TP+FN} \times 100 \quad (9)$$

**Accuracy ( $A_{cc}$ ):** This is the degree to which the result of our measurement, calculation, or specifications conforms to the correct or standard value and is calculated as follows:

$$A_{cc} = \frac{TP+TN}{TP+FN+TN+FP} \times 100 \quad (10)$$

The temperature test will be carried out by taking the temperature of few individuals and compare with the device response. This is because the temperature increase in this study do not contribute to the engine shutdown as it is not due to alcohol intake. Alcohol only widens the blood vessels, making more blood to flow to the skin to make you blush, feel warm and toasty. The heat from that extra blood passes out of the body, causing the temperature to drop (Swiner 2021). Increase in temperature is considered to be caused by an infection or illness or due to other factors that the driver most take note for clinical action, such as fever, Covid-19, cough, seasonal flue, sore throat, cold and catarrh, etc.

### 3. Results

#### 3.1 Simulation Results

The simulation was carried out in stages according to the block diagram in Figure 1 and the results are presented in Figures 10 to 15. Figure 10 presents the general simulated circuit of the alcohol and temperature monitoring system, while Figures 11 to 15 presents the behavior of the circuit at sensing alcohol and temperature levels which includes the boot success, temperature high, safe to drive, alcohol high, and message sent.

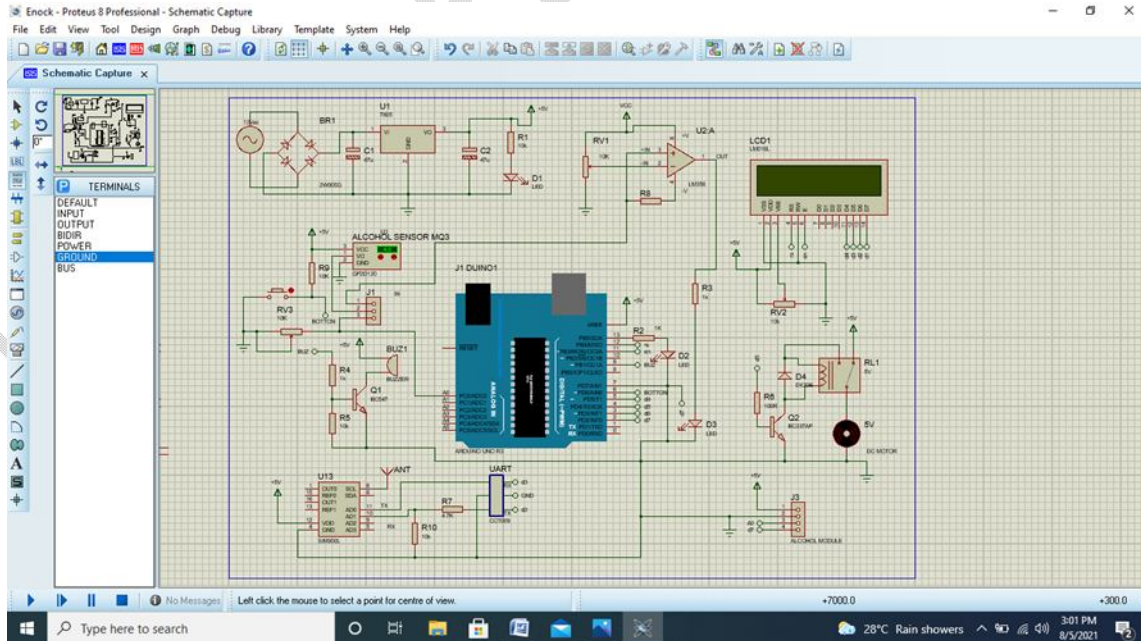

Fig. 10 Simulated general circuit

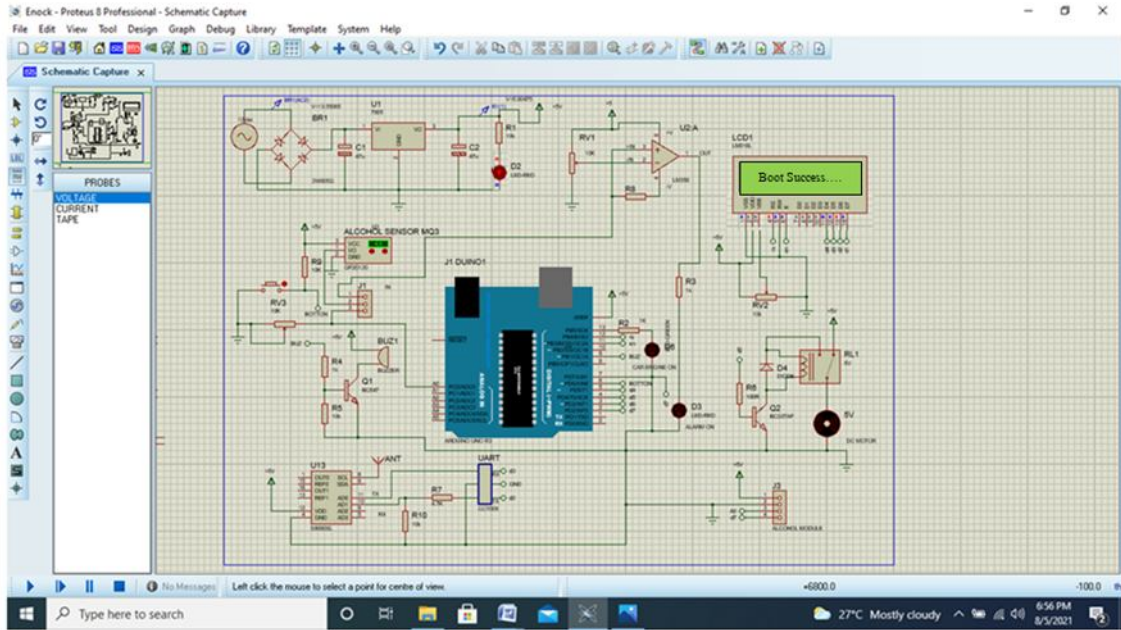

Fig. 11 Simulated result with system initializing (boot success)

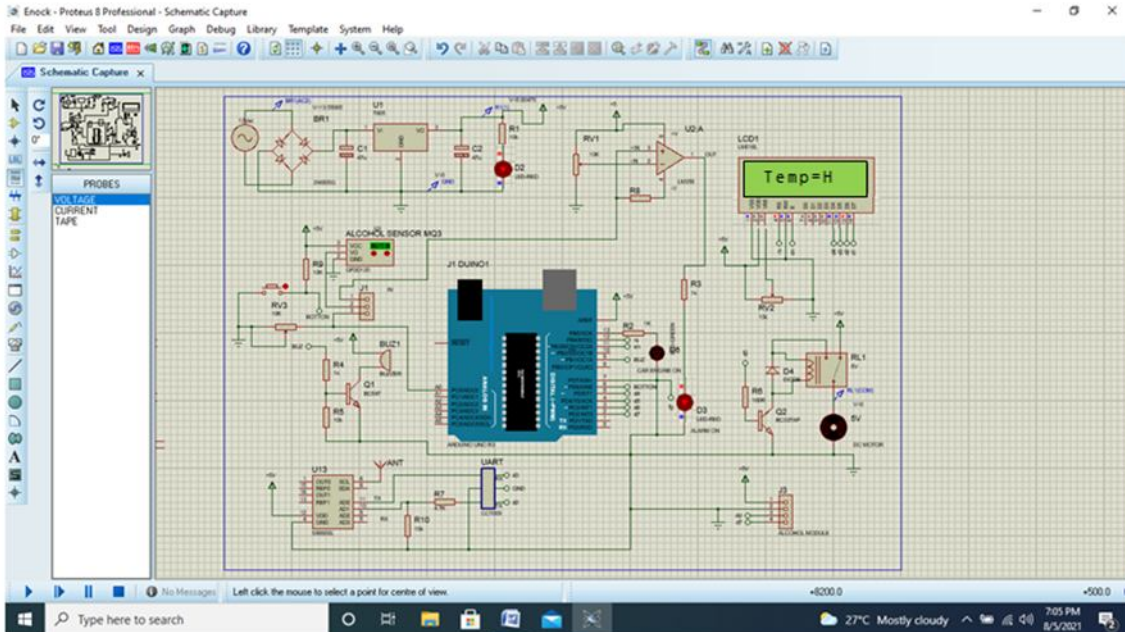

Fig. 12 Simulated result indicating temperature high

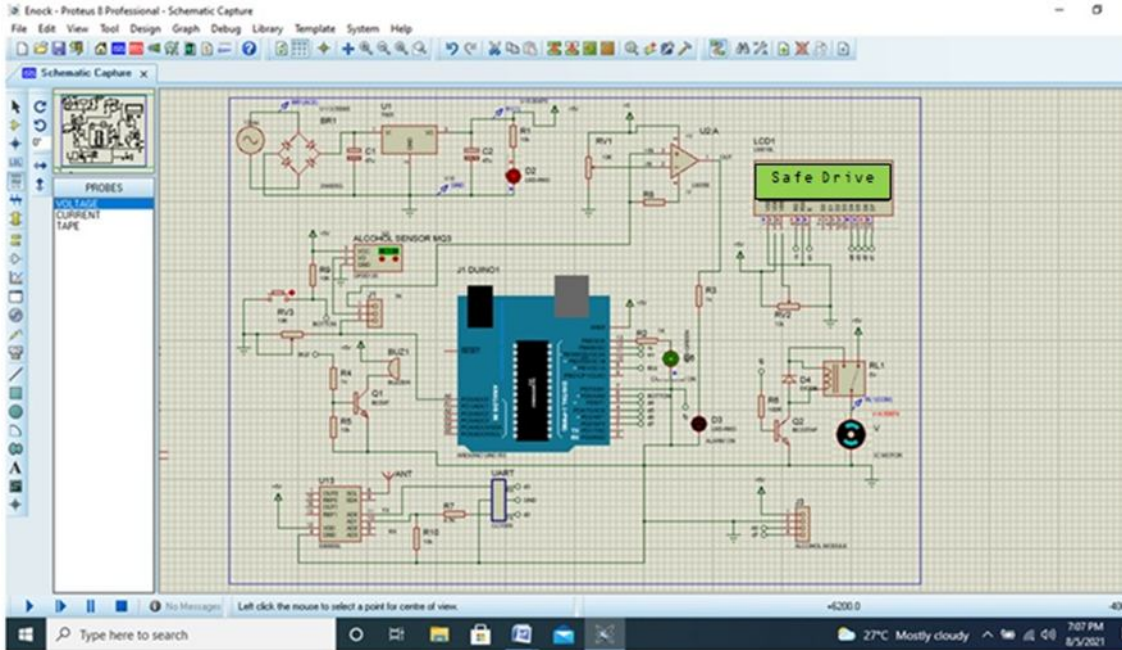

Fig. 13 Simulated result indication safe drive (low alcohol level)

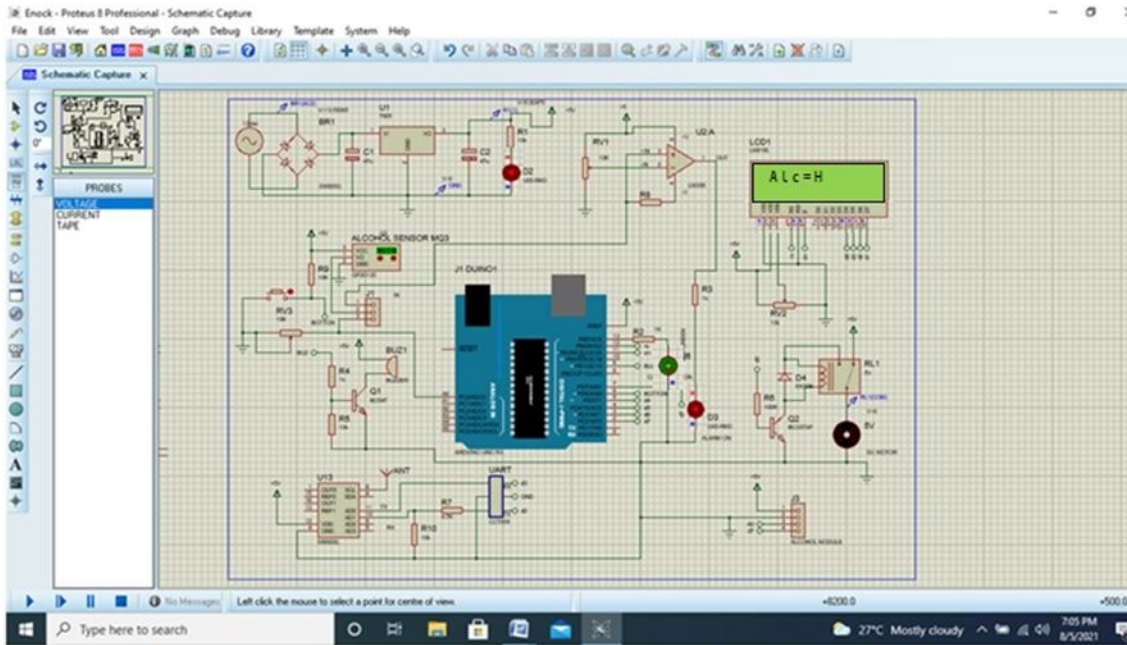
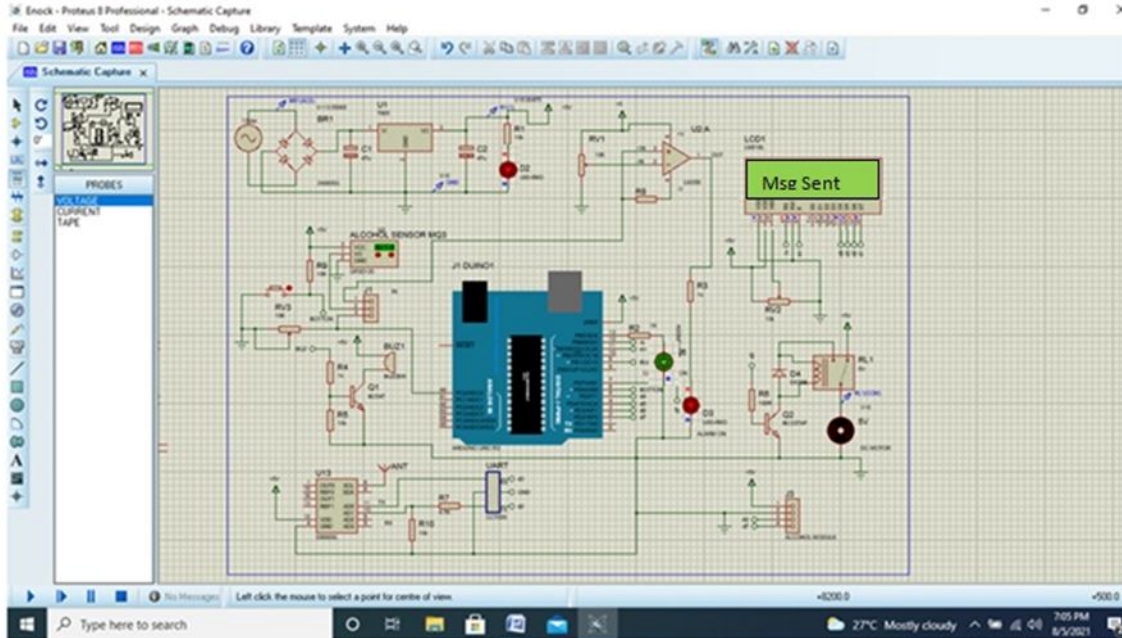

Fig. 14 Simulated result indicating high alcohol level



**Fig. 15** Simulated result indicating message sent

Figure 11 shows the simulation result when the system has been powered ON and the initializing sequence has been completed indicating boot success. Figure 12 indicating the temperature high (above 37.2°C), making the red LED glows there by continues alarm and motor supply reading 0V. In Figure 13, the alcohol level was normal, the green LED is 'ON', the motor 'ON', Red LED 'OFF' and Alarm 'OFF'. While in Figure 14 which indicates the alcohol level high, results to the Green LED 'ON', Red LED 'ON', Alarm 'ON' and the motor 'OFF'. Then SMS message is also sent to the authority, friend or spouse in about 10 seconds as shown in Figure 15. Message will indicate the alcohol body level content.

### 3.2 Hardware Construction

#### 3.2.1 Circuit Construction

The construction was carried out first on a bread board to ensure that the circuit is working as required, then transferred to the PC board for permanent soldering. The microcontroller and the Arduino Uno exists as a component while the temperature sensor, the alcohol sensor, the LCD, the relay unit and every other component in the system were interfaced with the microcontroller and Arduino board. The shunt and limiting resistors were also connected to limit and control the flow of current to the input terminals of each component. The constructed circuit showing the top view of the device is shown in Figure 16.

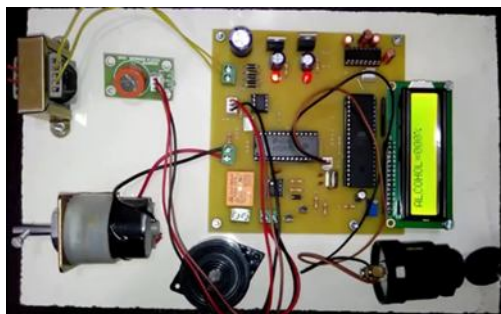

**Fig. 16** Constructed vehicle driver's alcohol and temperature monitoring system

### 3.2.2 Casing and Packaging

A casing measuring 10cm x 10cm x 3cm was finally provided to the system for mechanical protection. It is provided with 2no. of 1cm diameter holes for both the alcohol sensor and push bottom switch, 4no. of 0.25cm diameter holes within 0.5cm diameter grooves at the edges of its top side for screw locks, 1no. of 0.7cm diameter hole for the power input. Others are 1no. of 7cm x 3.5cm hole for the LCD and 1no. of 1.5cm x 2cm for temperature sensor, 2.5cm x 1.2cm thermometer, 1cm diameter power switch and 1cm diameter hole for the nub. Finally, provision of 1cm diameter has been provide at the 4 sides for the system for ventilation. The complete isometric diagram of the casing showing its three views (Front, Side and Top) and the various dimensions is shown in Figure 17, while the complete packaged device with full casing showing its top and side view is shown in Figure 18.

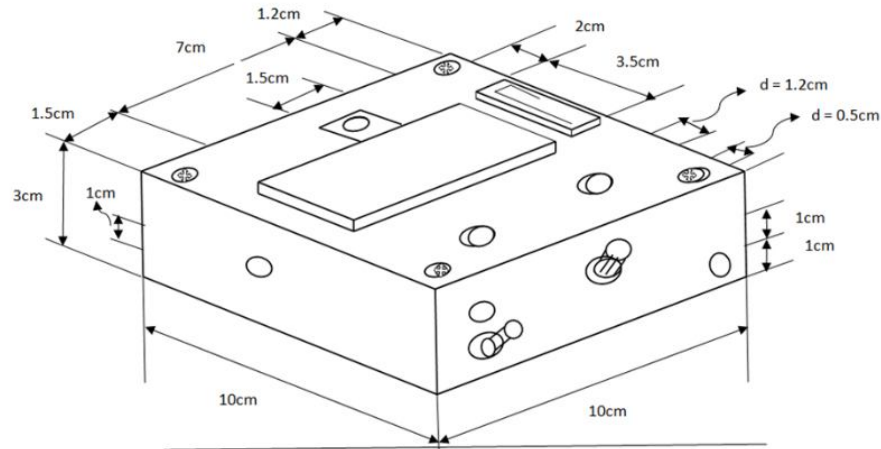

Fig. 17 The isometric diagram of the casing



a) Top view



b) Side view

Fig. 18 Complete packaged device with full casing

### 3.3 Analysis of Testing

#### 3.3.1 Continuity Test

In this study, the multi meter was used to perform this test. The multi meter was set at the continuity mode and the two ends of the probe was placed at the ends of a particular wire that is being checked for continuity, if there is a negligible resistance between the ends of the wire or path or the multi meter buzzer sounds then, the ends or path is continuous.

#### 3.3.2 Power ON Test

In this test, we take a multi meter and put it in voltage mode and the output of the transformer was checked for 12V AC. This voltage was then applied to the power supply circuit (without the microcontroller to avoid damage to the controller in case the voltage is above 12V). The power input to the voltage regulator was also checked and ascertained to be 12V input and 5V output. This 5V output is fed to the microcontroller at the 40th pin. That is to say the voltage at the 40th pin is 5V. The voltages at the other terminals were also checked and ascertained to be as per required as specified in the circuit.

### 3.3.3 Measurement of Blood Alcoholic Content

The device was tested with forty (40) volunteered persons selected at random from bear parlors and event centers for Four (4) weeks. An average of Ten (10) persons were tested per week for low/high Body Alcohol Content of those that have consumed varying percentage of alcohol ranging from Two (2) standard drink to fifteen (15) standard drinks. This was carried out by allowing them to sit at the driver side of the test vehicle, while the device was placed on the dashboard at the driver's side and using their normal breath the corresponding device response was noted. The device response was recorded between 40cm (just above the steering) and 90cm from the dashboard depending on the height of the driver and their seat adjustment. The number of standard drinks, weight and drinking time in hours were also recorded and used to calculate their Blood Alcoholic Content using equations (1) to (7). The calculated and measured Blood Alcoholic Content were compared and presented in Table 1.

Table 1: Calculated Blood Alcohol Content versus device response

Sex	Alcohol Consumed	Alcoholic Content (%)	Alcohol Content (g)	Weight (lbs)	Weight (g)	Gender Cons. r	Row Value x 100 (%)	Drinking Time (hr)	BAC	Device Response
M	10 of 12oz	5	140	203	92162	0.68	0.223	4.0	0.16	High
M	4 of 1.5oz	40	56	120	54480	0.68	0.151	5.0	0.08	High
M	12 of 1.5oz	40	168	132	59928	0.68	0.412	4.0	0.35	High
F	2 of 5oz	12	28	176	79904	0.55	0.064	1.5	0.04	High
F	3 of 5oz	12	42	110	49940	0.55	0.153	1.0	0.14	High
M	15 of 1.5oz	40	210	128	58112	0.68	0.531	5.0	0.46	High
F	7 of 12oz	5	98	132	59928	0.55	0.297	3.0	0.25	High
M	3 of 5oz	12	42	172	78088	0.68	0.079	2.5	0.04	Low
F	1 of 1.5oz	40	14	176	79904	0.55	0.032	1.0	0.02	Low
M	3 of 12oz	5	42	128	58112	0.68	0.106	3.0	0.06	High
M	9 of 12oz	5	126	141	64014	0.68	0.289	4.0	0.23	High
F	3 of 5oz	12	42	137	62198	0.55	0.123	2.0	0.09	High
M	3 of 1.5oz	40	42	159	72186	0.68	0.086	1.5	0.06	low
M	8 of 12oz	5	112	143	64922	0.68	0.254	3.5	0.20	High
F	5 of 5oz	12	70	198	89892	0.55	0.142	2.5	0.10	High
M	8 of 12oz	5	112	163	74002	0.68	0.223	3.0	0.18	High
F	4 of 1.5oz	40	56	172	78088	0.55	0.130	1.0	0.12	High
M	7 of 12oz	5	98	172	78088	0.68	0.185	1.5	0.16	High
M	7 of 12oz	5	98	165	74910	0.68	0.192	1.5	0.17	High
F	6 of 12oz	5	84	198	89892	0.55	0.170	2.0	0.14	High
M	6 of 1.5oz	40	84	210	95340	0.68	0.130	4.0	0.07	low
M	5 of 1.5oz	40	70	167	75818	0.68	0.136	1.0	0.12	High
M	5 of 12oz	5	70	132	59928	0.68	0.172	3.0	0.13	High
F	3 of 1.5oz	40	42	200	90800	0.55	0.084	2.0	0.05	High
M	6 of 5oz	12	84	137	62198	0.68	0.199	2.0	0.17	High
M	7 of 12oz	5	98	210	95340	0.68	0.151	3.0	0.11	High
F	10 of 12oz	5	140	163	74002	0.55	0.344	3.0	0.30	High
M	8 of 12oz	5	112	167	75818	0.68	0.217	4.0	0.16	High
F	8 of 12oz	5	112	154	69916	0.55	0.291	4.0	0.23	High
M	6 of 5oz	12	84	210	95340	0.68	0.130	4.0	0.07	low
M	9 of 12oz	5	126	162	73548	0.68	0.252	4.5	0.18	High
M	8 of 12oz	5	112	200	90800	0.68	0.181	3.5	0.13	High
F	9 of 12oz	5	126	137	62198	0.55	0.368	4.0	0.31	High
M	3 of 1.5oz	40	42	141	64014	0.68	0.096	2.0	0.07	High

M	4 of 5oz	12	56	128	58112	0.68	0.142	2.0	0.11	High
M	13 of 12oz	5	182	159	72186	0.68	0.371	5.0	0.30	High
M	10 of 12oz	5	140	210	95340	0.68	0.216	5.0	0.14	High
F	9 of 12oz	5	126	141	64014	0.55	0.358	3.0	0.31	High
M	12 of 12oz	5	168	162	73548	0.68	0.336	5.0	0.26	High
M	5 of 5oz	12	70	139	63106	0.68	0.163	3.0	0.12	High

Table 1 is the result of comparison between the calculated and measured BAC of the individuals. It is observed that the device response is quite comparable to the calculated values except for few cases which did not agree with the calculated values. This could be because of differences in body metabolism, weight and elapse drinking time. Those with high body metabolism, especially men with heavy weight as observed in the table, their body can metabolize the alcohol over the drinking period and their measured BAC may indicate a low even when the calculated value is high. Same with those that have low body metabolism especially in female. Even if they have heavy weight, their body cannot metabolize the alcohol over the drinking period and their measured BAC may indicate a high even when the calculated value is low. The body temperature of selected few individuals were taken and the result agreed with the device response as shown in Table 2.

Table 2: Body temperature and device response

S/N	Temperature (°C)	Device Response
1	36.2	normal
2	36.5	normal
3	36.1	normal
4	37.4	High
5	37.5	High
6	36.8	normal
7	36.3	normal
8	37.8	High
9	37.1	normal
10	38.0	High

### 3.3.3 Performance Evaluation Test

The performance evaluation was carried out to ascertain the functionality of the constructed device based on the Blood Alcoholic Content test. The true positive, false negative, false positive and true negative values were recorded and presented in Table 3. The result was used to calculate sensitivity, specificity and accuracy of the device using equations (8) to (10).

Table 3: Performance evaluation result

S/N	Sensor Test	No. of Trials	True Positive (TP)	False Negative (FN)	True Negative (TN)	False Positive (FP)
1	Alcohol Test	40	33	3	3	1

Table 3 is the analysis result for the test carried out on the constructed device. The output test results revealed some vital information that was useful in the analysis for the alcohol test. A total of 40 trials was carried out, out of which the number of true positive was about 33, false negative was 3, true negative was about 1, and false positive was 3.

The specificity ( $S_p$ ) of the constructed device was calculated using Equation 8 as:

$$S_p = \frac{3}{3+1} \times 100 = 75.0\%$$

The Sensitivity ( $S_e$ ) of the constructed device was calculated using Equation 9 as:

$$S_e = \frac{33}{33+3} \times 100 = 91.7\%$$

The Accuracy ( $A_{cc}$ ) of the constructed device was calculated using Equation 10 as:

$$A_{cc} = \frac{33+3}{33+3+3+1} \times 100 = 90.0\%$$

The parameters evaluated, gives the device performance in terms of differentiating alcohol detection and other gases and fragrances.

#### 4. Discussion

The constructed vehicle alcohol and temperature monitoring system when subjected to various tests revealed vital information that established its functionality. The continuity test showed that the circuit was continuous (i.e. no short circuit, broken conductors nor damaged components or excessive resistance along the path of connections). While the power 'ON' test revealed that, the voltage at different terminals was according to the requirement and specification of the simulated circuit. This is similar to that of Prashant et al.(2014)who worked on road accident avoiding system using drunken sensing technique and Dada et al.(2017) who designed a prototype alcohol detection and engine locking system by using an Arduino Uno Microcontroller interfaced with an alcohol sensor.

Findings from the performance analysis on the device revealed that the sensitivity is  $\approx 92\%$  while specificity is  $\approx 75\%$ . This implies that the system will rightly detect 92% of alcohol around the unit but will fail to detect only 8% of same. The device will also correctly identify 75% of alcohol absence around it but will fail to identify 25% of same. The accuracy of the device has been calculated to be 90%. That is, the constructed device conforms to the correct value specification of the simulated circuit. This implies that, the objective of using the device for accurate Alcohol Content monitoring of an on board driver of a vehicle and reduction in the number of road accident due to drunk driving is possible and we are 90% sure. Both results of the alcohol levels (low/high) and the body temperature reading are displayed on the LCD. This shows an optimal performance of the device. However, of all the previous work reviewed, like Dada et al. (2017), Aparna et al. (2020), Ayaz et al. (2020), Shukla et al. (2020), Francis et al. (2019), Prathamesh et al. (2019), Keerthena et al. (2018), etc. none of the similar works were able to calculate specificity, sensitivity and accuracy which forms the novelty and contribution of this study to the literature, but the result on construction and testing of the device were in line with previous work carried out such as Dada et al. (2017)who designed a prototype alcohol detection and engine locking system by using an Arduino Uno Microcontroller interfaced with an alcohol sensor, Aparna et al. (2020) who implemented a prototype version Alcohol detection system in order to control drunk and driving, Ayaz et al. (2020)who developed a system which will lock the engine when the driver is drunk using a microcontroller and alcohol sensor, and Keerthena et al. (2018) who proposed drunk driving detection using car ignition locking. Another contribution in this study is that, this device has a body temperature detecting feature in addition to the alcohol level sensing ability which have not been included in other study.

#### 5. Conclusions

The vehicle alcohol and temperature monitoring system which was aimed at avoiding accidents caused by drunk driving and ascertaining body temperature of an 'On' board driver was constructed according to the specifications from simulated results and tested. The sensors send data to the microcontroller which will then be displayed on the Liquid Crystal Display (LCD). This Study showed that if, the (supposed) driver of a vehicle is drunk, and this device is fitted on the Steering wheel or any point close to where the breath of the driver can be picked by the alcohol Sensor, the engine of the vehicle will not start and if he boarded drunk (alcohol level high) while the engine was already running, the device will give a beep sound and an alarm and shutdown the vehicle (that is the DC motor will stop running) in a given time then, a message will be sent to an authorized registered number. The body temperature monitoring feature in addition to the alcohol sensing and engine locking mechanism in this study, made this work

novel and different from other previous works done in this area. The device if installed in vehicles will significantly reduce the rate of road accidents associated to drunk driving as such help in preserving the lives of road users and assisting the law enforcement agencies in dealing with such problems.

## Reference

Adriazola-Steil C, Banerjee SR, Sharpin AB (2019) Report: 1.35 Million People Killed Every Year in Traffic Crashes. And Counting. In: The City Fix. <https://thecityfix.com/blog/report-1-35-million-people-killed-every-year-in-traffic-crashes-and-counting-claudia-adriazola-steil-subha-ranjan-banerjee-anna-bray-sharpin/>. Accessed 16 Jan 2022.

Agarwal U (2015) Software Engineering, 2nd edn. S.K. Kataria & Sons, New Delhi.

Aparna K, Dhanya TB, Anoob U, Deepa VR, Gireeshan M (2020) Alcohol Sensing Alert with Engine Locking System. *I J Psy Rehab* 24(6):4193-4196.

Yaz A, Amit M, Bramhanandam P, Priya S (2020) Alcohol Sensing Alert with Engine Locking. *I J DisasRecov Bus Cont* 11(3):156 – 163.

Dada EG, Hamit IH, Adebipe AL, Ajibuwa EO (2017) Alcohol Detection of Drunk Drivers with Automatic Engine Locking System. *J Eng Appl Sci* 6(1):060-104.

Enimola O (2019) Drink Driving Situation in Nigeria. In: Independent. Available via DIALOG. <https://independent.ng/drink-driving-situation-in-nigeria/>. Accessed 15 April 2022.

Eugene H (2018) College Physics, 2nd edn. Mc Graw- Hill Education, New York.

Francis GA, Wilson M, Selkar WR (2019) Health Monitoring with Alcohol Detection and Ignition Control System using IOT. *I J Innov Tech Expl Eng* 8(6):203 – 206.

Guardian Nigeria (2022) Nigeria lost 2,927 males to road accidents in nine months. <https://guardian.ng/news/nigeria-lost-2927-males-to-road-accidents-in-nine-months/>. Accessed 15 April 2022.

Jha DK (eds) (2016) Computational Physics. Discovery publishing House PVT Ltd., New Delhi.

Keerthena K, Ramya G, Bharathi N, Scholar UG (2018) Drunk Driving Detection Using Car Ignition Locking. *I J Eng Res Tech* 119(16):2997 – 3007.

Metric Conversions (2020) Pounds to grams. <https://www.metric-conversions.org/weight/pounds-to-grams.htm>. Accessed 28 March 2023.

Morojele NK, Dumbili EW, Obot IS, Parry CDH (2021) Alcohol consumption, harms and policy developments in sub-Saharan Africa: The case for stronger national and regional responses. *Drug and Alc. Rev.* 40:402–419. doi:10.1111/dar.13247.

Nigerian Tribune (2022) Road crashes: The loss of 14,773 Nigerians in three years. <https://tribuneonlineng.com/road-crashes-the-loss-of-14773-nigerians-in-three-years/>. Accessed 15 April 2022.

Odeigah OW, Patton R, Dumbili EW (2022) Nigeria: A Country in Need of a Standard Drink Measure and Low-Risk Drinking Guidelines. *J Stu. Alc, Drugs* 83(3):450–451.

Ogazi C, Edison E (2012) The drink driving situation in Nigeria. *Traff Inj Prev* 13(2):115-9. doi:10.1080/15389588.2011.645097.

Ojha M, Sheetal M, Shranddha K, Diksha T (2016) Microcont Automatic Plant Watering System. *I Acad Sci Eng Tech* 5(3):25-43.

Ozor C (2017) 90 per cent of road accidents caused by alcohol, hard drugs – FRSC. In: Vanguard Nigeria. Available via DIALOG. <https://www.vanguardngr.com/2017/11/90-per-cent-road-accidents-caused-alcohol-hard-drugs-frsc/>. Accessed 15 April 2022.

Prashanth KP, Padiyar K, Naveen KPH, Kumar KS (2014) Road Accident Avoiding System using Drunken Sensing Technique. I J Eng Res Tech 3(10):818-823.

Prathamesh D, Rushiraj C, Abhishek S, Sonali S, Bhandari GM (2019) Driver Safety with Smart Alcohol Detection and Control System. I J Res Tech Innov 4(1):2456-3315.

Sasu DD (2022) Number of road traffic casualties in Nigeria 2020-2021. In: Statista. Available via DIALOG. <https://www.statista.com/statistics/1296025/total-number-of-road-casualties-in-nigeria/>. Accessed 15 April 2022.

Shukla P, Utkarsh S, Sridha S, Rakash RSR (2020) Automatic Engine Locking System through Alcohol Detection. I J Eng Tech Res 9(5):57 – 60.

Sivakuma A, Dhivya P (2016) Smart Helmet System Using Alcohol Detection for Vehicle Protection. I J Adv Sci Eng Res 1(1):570 – 576.

Swiner CN (2021) How Alcohol Affects Your Body. In: WebMD. Available via DIALOG. [https://www.webmd.com/mental-health/addiction/ss/slideshow-alcohol-body-effects#:~:text=A%20Change%20in%20Body%20Temperature&text=Alcohol%20widens%20your%20blood%20ve ssels,causing%20your%20temperature%20to%20drop](https://www.webmd.com/mental-health/addiction/ss/slideshow-alcohol-body-effects#:~:text=A%20Change%20in%20Body%20Temperature&text=Alcohol%20widens%20your%20blood%20ve ssels,causing%20your%20temperature%20to%20drop.). Accessed 08 April 2023.

Ventures Africa (2021) Pernod Ricard Nigeria champions ‘don’t drink and drive’ campaign in the country. <https://venturesafrica.com/pernod-ricard-nigeria-champions-drunk-driving-campaign-in-nigeria/>. Accessed 15 April 2022.

Waveshare (2023) Contact-less Infrared Temperature Sensor - MLX90614. In: Grobotronics. <https://grobotronics.com/contact-less-infrared-temperature-sensor.html?sl=en>. Accessed 08 April 2023.

Welcome MO, Pereverzev VA (2010) Limit of blood alcohol concentration: A major problem to solve in Nigeria. Eur Psych 25(Suppl 1):544.

World Health Organization (2018) Global status report on alcohol and health 2018. <https://apps.who.int/iris/bitstream/handle/10665/274603/9789241565639-eng.pdf> Google Scholar. Accessed 24 March 2023.

World Health Organization (2021) Road traffic injuries. <https://www.who.int/news-room/fact-sheets/detail/road-traffic-injuries>. Accessed 12 Jan 2022.

Ziats M (August 24, 2021). How to Calculate Blood Alcohol Content (Widmark Formula). In: WikiHow. [https://www.wikihow.com/Calculate-Blood-Alcohol-Content-\(Widmark-Formula\)](https://www.wikihow.com/Calculate-Blood-Alcohol-Content-(Widmark-Formula)). Accessed 28 March 2023.