

Design and Implementation of a battery temperature display system built on the MC9S12XS128 platform

ABSTRACT

With the rapid development of society, people's awareness of environmental protection is becoming stronger and stronger. Due to the greater demand for energy, new energy has become the object of attention. Now electric energy is widely used in all aspects of people's production and life. As a kind of device to store electric energy, battery has been paid more and more attention. How to extend the battery life and ensure the normal and stable operation of the battery has become the focus of research. This design carries on the analysis to the battery, uses the MC9S12XS128 single chip microcomputer. The hardware design and software design of the single-chip microcomputer complete the collection and display of the battery temperature parameters, so as to grasp the performance parameters of the battery, After debugging the display system, the results show that the battery temperature display system can display the temperature status in real time, meeting the working requirements. The system can intuitively understand and master the working status of the battery. So that the battery can work safely and stably.

Key words: battery; single chip microcomputer; hardware design; software design

1 Introduction

As an energy storage device for storing electrical energy, batteries have become a research hotspot. The battery display system can comprehensively grasp the working status of the battery, timely charge and discharge the battery, and perform maintenance to improve the service life of the battery. The design of a battery temperature display system based on a microcontroller can enable us to accurately grasp the temperature parameters of the battery, thereby knowing the working status of the battery. Battery display system has a broad application prospect in the field of new energy powered by electric energy.

2 Overall System Design

2.1 Working principle of microcontroller

A microcontroller is a type of integrated circuit chip, commonly known as a single-chip microcontroller. Microcontrollers are mainly composed of CPU, ROM, RAM, etc.^[1]. Its basic structure is shown in Figure 1. Diversified data acquisition and control systems enable microcontrollers to complete various complex operations, whether it is controlling operation symbols or issuing operation instructions to the system, all of which can be completed through microcontrollers. It can be seen that microcontrollers can be fully applied in intelligent electronic devices with their powerful data processing technology and computing functions. Simply put, a microcontroller is a chip that forms a system. Through the application of integrated circuit technology, data computation and processing capabilities are integrated into the chip, which can process data at a high speed; It is not a chip, but a computer system that has some logical function and is integrated into the chip. This design product has a small volume, light weight, low price, and is suitable for learning, application, and development. MCU is commonly used in intelligent devices, real-time industrial control, communication devices, navigation systems, household appliances, and other fields.

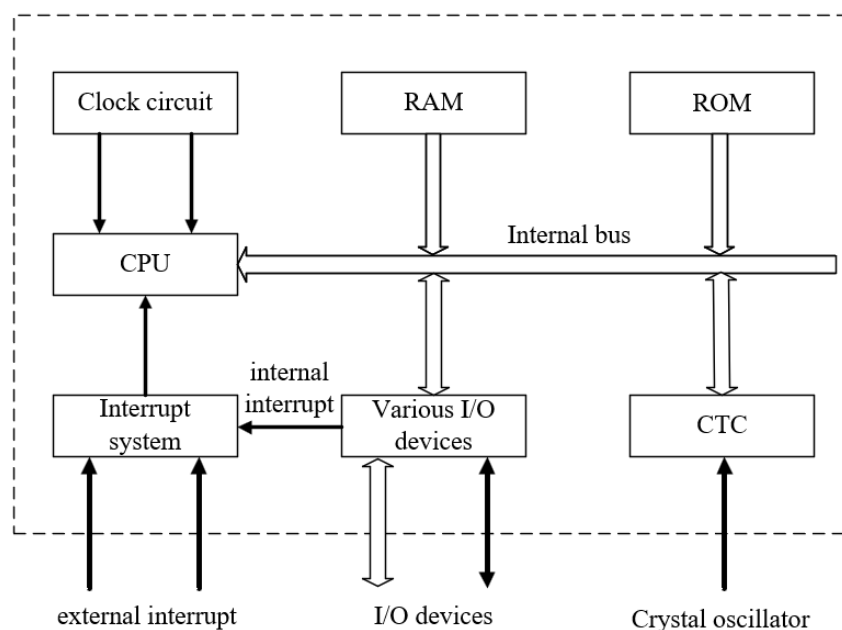

Figure 1 Basic structure of microcontroller

2.3 Sensor signal acquisition

Signal acquisition is the process of converting physical phenomena into data that can be recognized by computers^[2]. A measurement process begins with the use of sensors to convert physical signals into electrical signals. Sensors generally consist of four parts: sensors, converters, converter circuits, and auxiliary power supplies^[3]. As shown in Figure 2

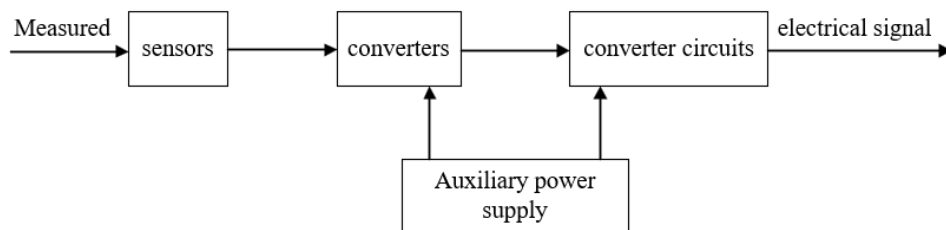

Figure 2 Sensor composition

2.4 Design scheme

This display system design includes three parts: (1) hardware design, (2) software design, (3) system debugging. The main content of hardware design includes minimal system design, acquisition module design, and display module design. The main content of software design includes main program design, collection program design, and display processing program design. System debugging mainly involves displaying and debugging battery temperature parameters.

3 Hardware design

3.1 Performance Overview of MC9S12XS128

MC9S12XS128 is a 16 bit microchip consisting of a 16 bit processor (CPU12X), 128KB flash memory, 8KB flash memory, and 8KB data flash memory. The main functional modules are internal memory, internal storage module, 2CG serial communication system, SPI serial interface, MSCAN module and 8 input/output counter modules, periodic timing module PIT, 16 channel conversion module ADC, 8-channel pulse PWM, and input/output digital I/O ports^[3]. The 64 pin MC9S12XS128,

MC9S12XS128MAL, MC9S12XS128MAA, and MC9S12XS128MAL have 8 pins and 112 pins. The MC9S12XS series has rich input/output terminal resources, including terminal M, terminal P, terminal H, terminal J, and terminal D. The terminal integrates 11 functional modules such as terminals, and the port feeding is mainly multi-channel terminals, usually with multiple functions., And all ports have universal I/O port functionality.

3.2 Minimum System Design

3.2.1 Power circuit

The power circuit is essential for any circuit that can provide stable operating voltage for the microcomputer. The external power supply voltage of MC9S12XS128 microcomputer is 5V, and the 5V DC power supply can directly supply power to the MCU^[4]. In this design, the LM2940 chip is used to construct the power circuit. In Figure 3, the positive terminal of the battery is the power source. The power is provided to the power chip through F11, which is a fuse for the 1A circuit. LM2940 is a power conversion chip that can convert 5V power supply voltage to 5V. MAGID12 serves as a power indicator. The capacitors in the circuit achieve voltage stability and filtering functions. VCC is a 5V power output. If R2 and R3 separate the power supply voltage and input it to ports a and D of the MCU, the battery voltage can be monitored. The power supply voltage determines the values of R2 and R3, which ensure that ADB does not exceed 5V.

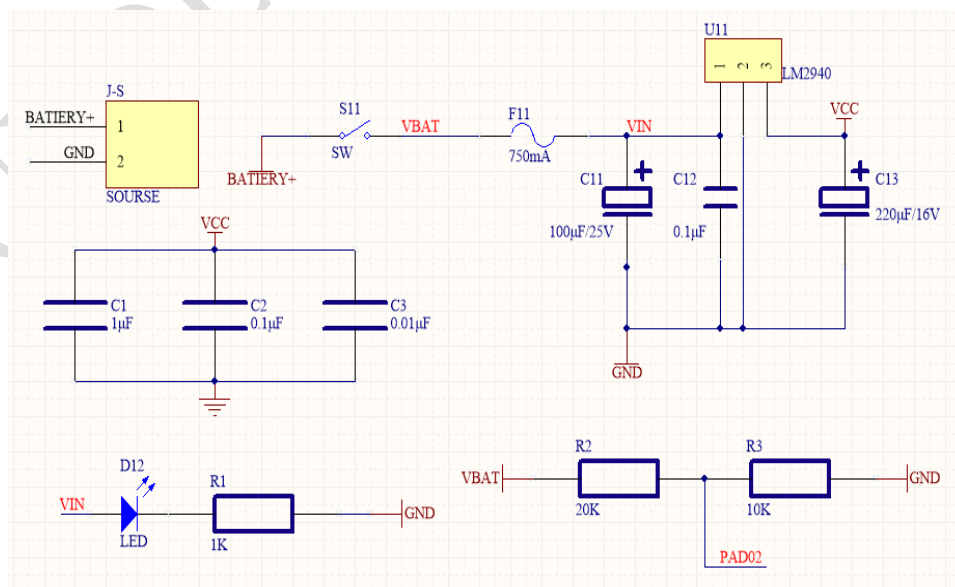

Figure 3 Power Supply Circuit Based on LM2940

3.2.2 Clock circuit

Like the power circuit, the clock circuit is also an essential circuit in the operation of microcontrollers. This design is a clock circuit connected in Pierce form, which also uses a crystal oscillator to generate clock pulses. In Figure 4, C1 and C2 are the filtering capacitors of the crystal oscillator, and Rb is the resistance of the crystal oscillator. The third clock connection mode uses an external oscillator as the clock input, where the clock is input from an external inline and the external inline is temporarily paused.

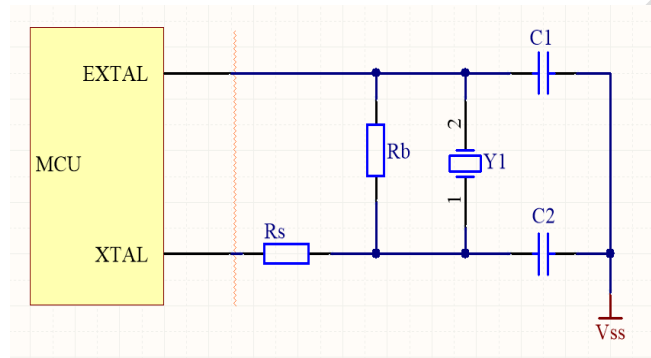

Figure 4 Clock Circuit

3.2.3 Reset circuit and BDM circuit

The reset circuit and BDM circuit of MC9S12XS128 are shown in Figure 5. The reset circuit uses MAX809 as the reset chip. When the input voltage of pin 3 of the chip is lower than 5V, the output voltage of pin 2 of the chip is higher. Restore the position of the microcomputer by changing it to a low position; The manual recovery of BDM circuit in K1 microcomputer is the debugging interface circuit of microcomputer; The BDM connection consists of 6-pin, 1-pin and single-chip BKGD connection, 2-pin and single-chip. It is composed of splicing, 4-pin and single-chip recovery, 6-pin and single-chip connection, and 3-pin and 5-pin. When the BDM port is reversed in this way, the downloaded BKGD can be connected to the VCC of the target board and the download program can be burned. Therefore, in order to prevent consumption caused by port plugins, people have designed BKGD ports with 3-pin BDM ports.

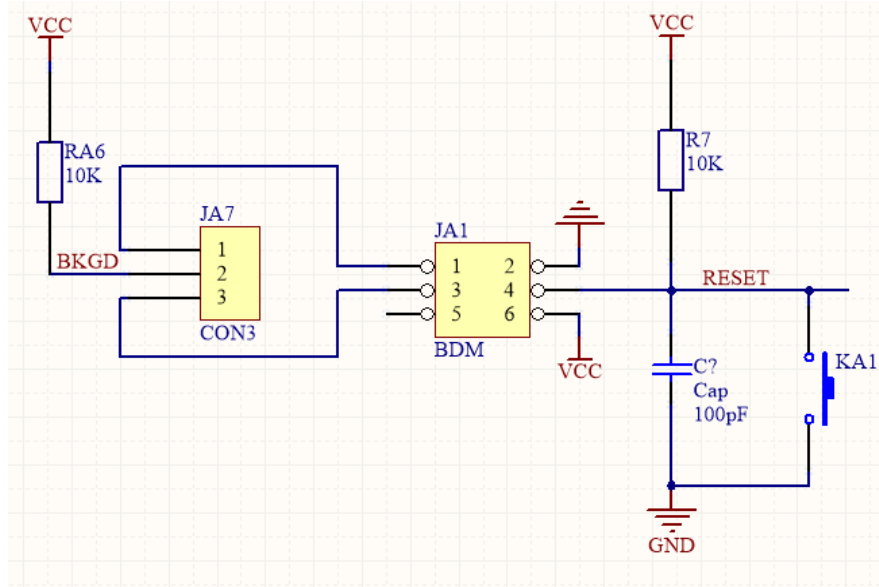

Figure 5 Reset circuit and BDM circuit

3.3 Collection module design

DS18B20 is a commonly used digital temperature sensor, which has a small output digital signal volume, low hardware cost, prevents a large amount of vibration, and has high-precision characteristics [5]. The digital temperature sensor 18b20 is convenient and widely used for connection. There are LTM8877 and LTM8874.

The main feature of DS18B20 is its adaptability to a wider voltage range of 3.0-5.5 V, which can supply power to the data lines in the power model. DS18B20 adopts a single common interface method and requires terminal wires. DS18B20 supports many networks, but can also be connected to circuits for multi temperature measurement, and does not require any peripheral devices, including all sensor components and switch circuits. It is integrated in the form of a transistor in an integrated circuit, with a temperature range of -55 degrees to +125 degrees and an accuracy of -10 degrees to +85 degrees, which is ± 0.5 degrees. The programmable resolution is 9-12 bits, corresponding to high-precision temperature measurements of 0.5 degrees, 0.25 degrees, 0.125 degrees, and 0.0625 degrees. At a 9-bit resolution, the highest temperature can reach 93.75 ms; At a 12 bit resolution, the maximum temperature can reach 750 ms. The measurement results are directly generated into digital temperature signals and sent to the CPU. Serial transmission through a single wire bus system can be transmitted together with CRC verification codes, thus

having excellent interference prevention and error correction functions. When the polarity is reversed, the chip will not break due to heat and cannot function properly.

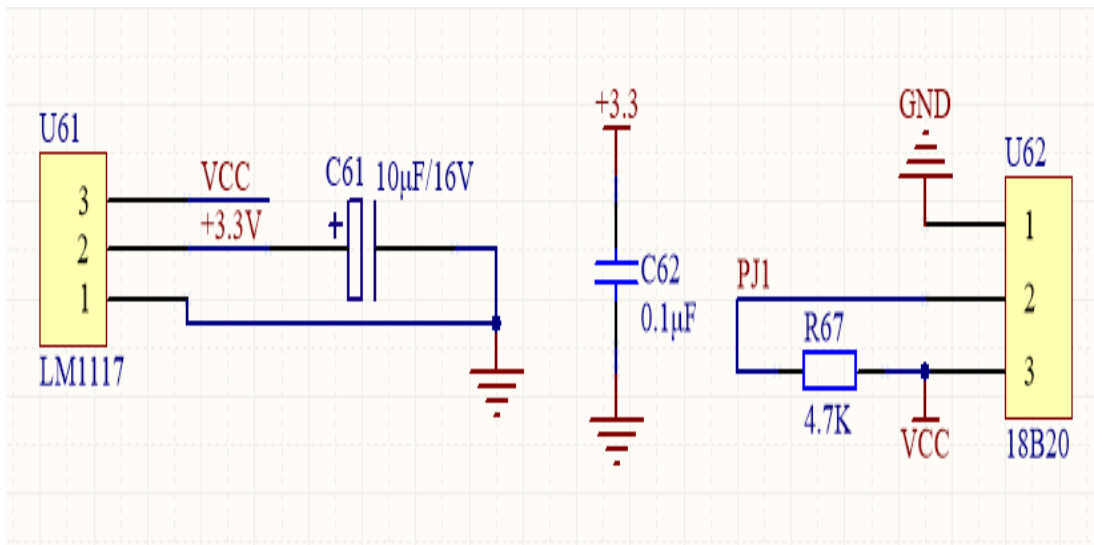

Figure 6 DS18B20 Circuit Schematic

3.5 Display module design

This design adopts digital tube as the display equipment, as shown in Figure 7. Each LED of digital tube consists of eight LEDs, and the eight LEDs are called 8-layer digital tube. It consists of an 8-digit digital tube with a decimal point marked by the letters A, B, D, and F G. Different numbers can be displayed by illuminating different segments. For example, if "2" is displayed, the segments A, B, G, E and D need to be lit. There are 4 groups of LEDs on a 4-segment common cathode digital tube module. These 4 groups share the same anode and each group uses the same cathode. The circuit of 4-bit 8-segment common-nitron digital tube is shown in Fig. 8.

Since the four groups of light emitting tubes use a common anode, the numbers displayed on the 4-bit digital tube at a certain time are the same. According to the limit of connecting floating point of the 4-bit digital tube, all digital tubes are connected with 470R resistor, and the anode is connected to 8 pieces of PP0 ~ PP7 [13]. The four cathode tubes of the digital tube switch four transistors. The base of the transistor is connected to the PK3 to PK0 columns of the microcomputer when passing through the resistor. Based on this circuit, a particular scanner has a P entry for the first level code output and a K

entry for the first wire extension. Scan the second code output K entry in such a way that the second code K entry causes three different numbers.

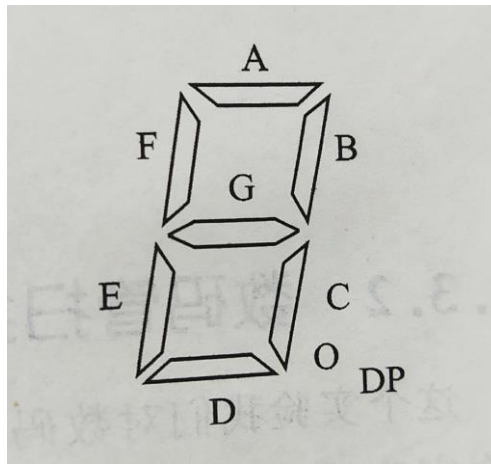

Figure 7 8-segment digital tube

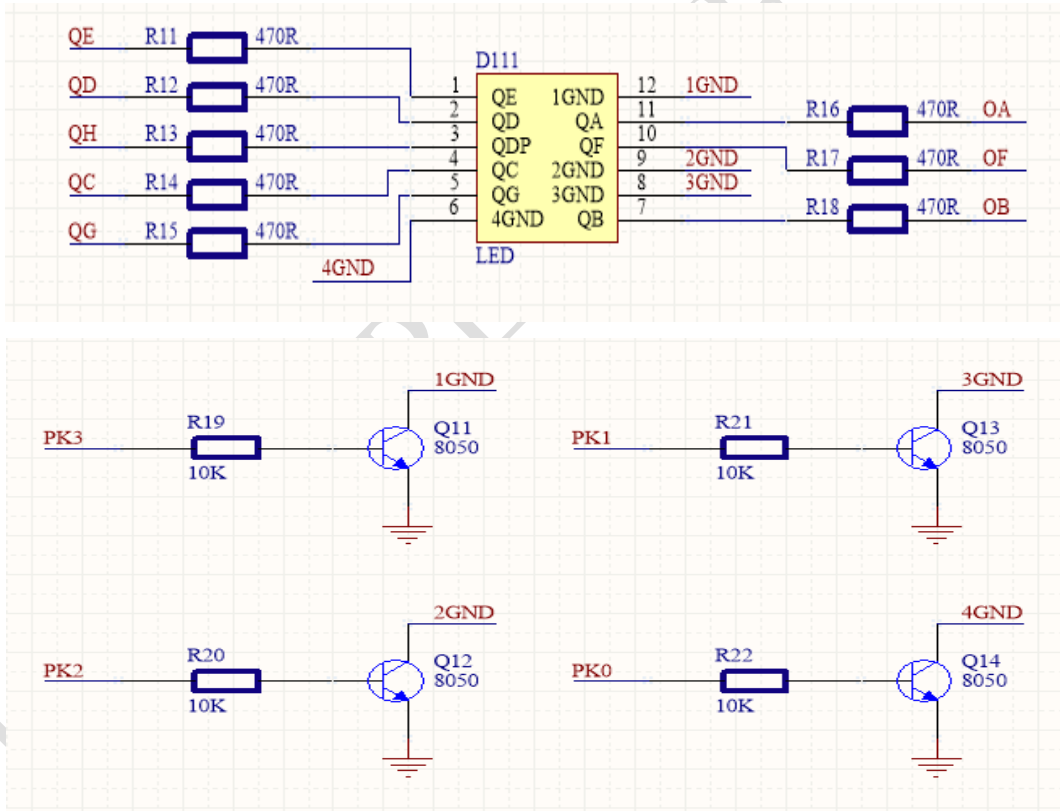

Figure 8 Circuit diagram of four-bit eight-section common cathode digital tube

4 Software design

4.1 Main Program Design

The basic process of the main program is shown in Figure 9. Firstly, the temperature

parameters of the battery are collected through the DS18B20 temperature sensor and converted into digital signals by processing the data from the microcontroller. Finally, use a digital display to show the temperature value. The main purpose of the initial program is to define each variable for each function and install the corresponding registers of the AD module in the microcomputer^[6].

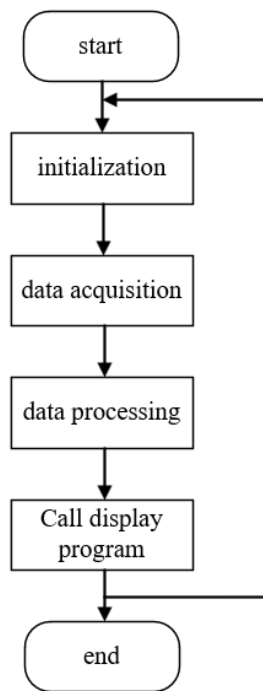

Figure 9 Main procedure flow

4.2 Acquisition program design

As shown in Figure 10, the acquisition principle of 18B20 is explained, the vibration frequency of the low-temperature coefficient vibrator is not affected by the temperature, and the pulse signal generating a fixed frequency is sent to the counter 1. The vibration frequency of the high temperature crystal vibrator clearly shows the signal obtained according to the temperature. This is entered into the input box of counter 2, i.e. the default value of indicator 1 and the temperature register are set to minus 55, and counter 1 removes the low temperature coefficient crystal vibrator. If the default value of counter 1 is reduced to 0, the default value of temperature register 1 is set. By increasing 1 and filling the default value of counter 1, the counter starts to re-calculate the pressure generated by the cryocounter crystal oscillator, which then becomes counters 2, 0 and its return register

value is the measured temperature. Its output is used to correct the preset value of the 1 counter.

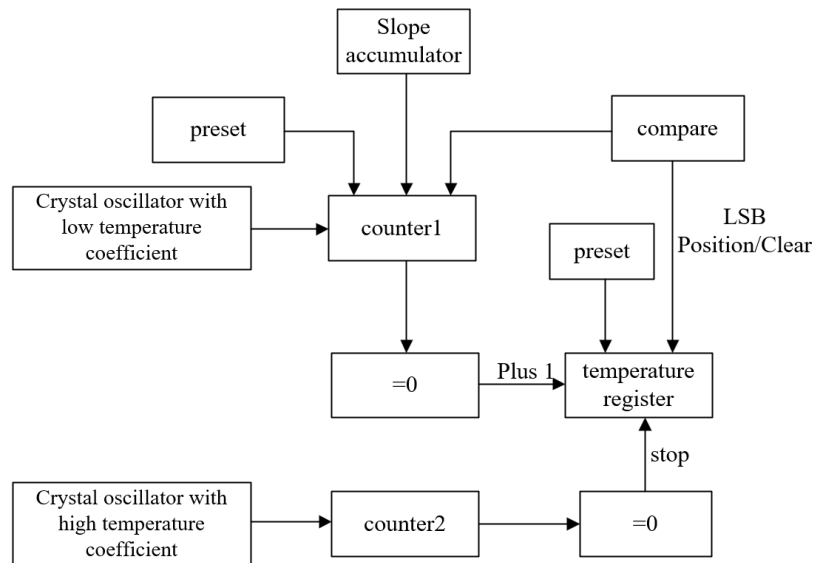

Figure 10 Collection principle of DS18B20

4.4 Display processing programming

In order for the four LEDs to display different numbers, the LEDs must be controlled by scanning. That is to say, when one of the LEDs lights on one and the other one lights on the next time, the four LEDs are opened at the same time due to visual damage to human eyes [7].

```
#pragma CODE_SEG __NEAR_SEG NON_BANKED
interrupt void scan(void)
{
  If (TFLG1_C0F == 1)
  {
    TFLG1_C0F = 1;
    TC0 = TCNT + 1250; // Set the output comparison time to 5ms
  }
  switch(single)
  {
  case 1:
    CONT1 = 1;
  }
}
```

```
CONT2 = 0;
CONT3 = 0;
CONT4 = 0;
if(data1==20)
    DATA=0x40;
else if(data1==0)
    DATA=0;
else
    DATA=shuma[data1];
break;
case 2:
CONT1 = 0;
CONT2 = 1;
CONT3 = 0;
CONT4 = 0;
DATA=shuma[data2];
break;
case 3:
CONT1 = 0;
CONT2 = 0;
CONT3 = 1;
CONT4 = 0;
DATA=shuma[data3];
break;
case 4:
CONT1 = 0;
CONT2 = 0;
CONT3 = 0;
CONT4 = 1;
```

```

DATA=shuma[data4];

break;

default:

break;

}

single +=1;

if(single == 5) single = 1;

}

#pragma CODE_SEG DEFAULT

```

5 System commissioning

5.1 Introduction to CodeWarrior

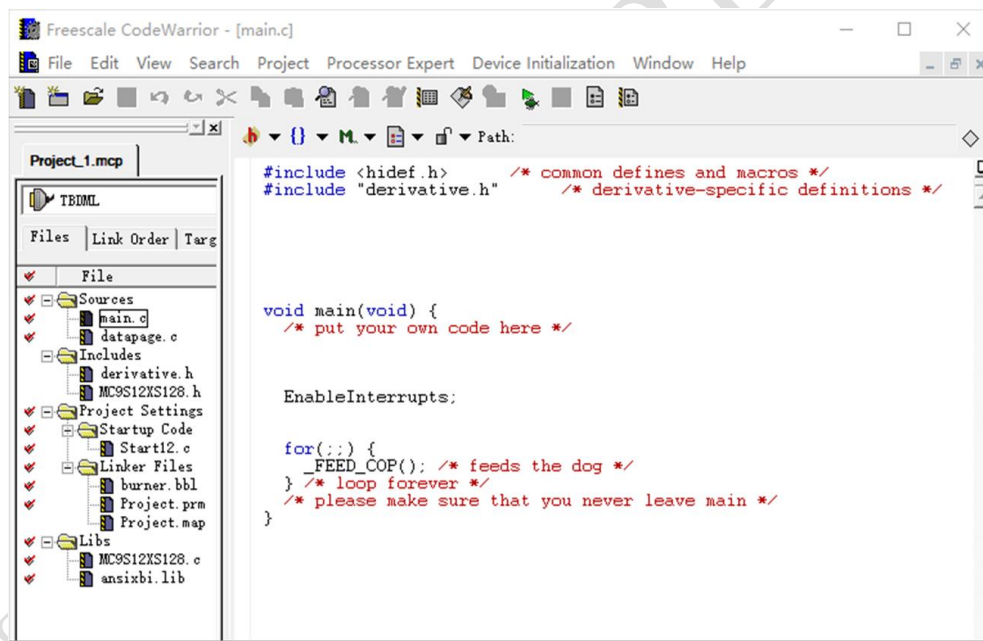



Figure 11 CodeWarrior work interface

CodeWarrior Development Studio is a complete integrated development environment. CodeWarrior Development Studio combines advanced debugging technology with simple sound development environment, and brings Chand Curve+source code level to a new level. Improved testability and aggregate application development Development Studio provide a high degree of visualization and automation. It provides a variety of assistance. To create applications easily and quickly [8]. Figure 11 shows the CodeWarrior work

interface

5.2 Battery temperature parameter display debugging

1. Connect the BDM downloader to the microcontroller and turn on the microcontroller power.
2. Open the file "Demo Code/Temperature Sensor/18B20. mcp" as shown in Figure 12.
3. Click  (Debug) button to download the source code to the microcontroller and enter the debugging window shown in Figure 13.
4. Click  (Start) button in the debugging window to start the program execution.
5. The current temperature parameters will be displayed on the digital display as shown in Figure 14.

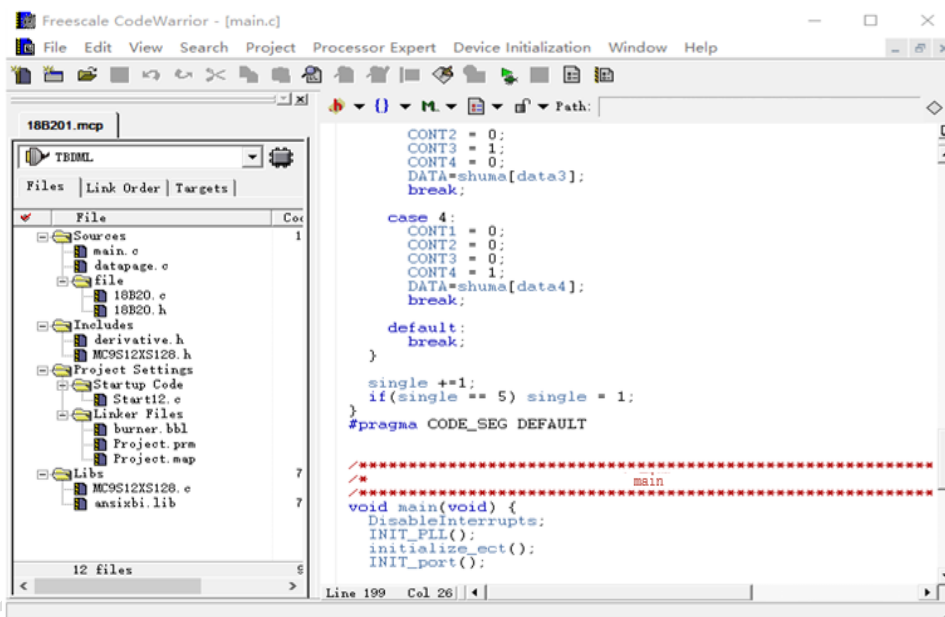

Figure 12 Software Program Interface

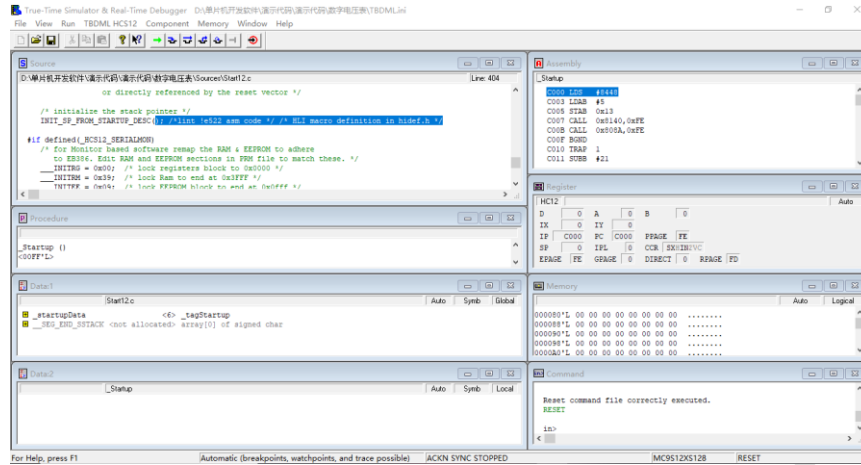

Figure 13 Software Program Debugging Interface

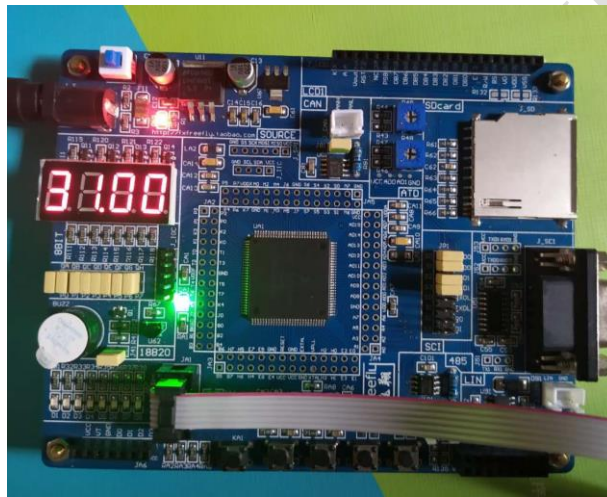

Figure 14 Temperature Results Display

6 Conclusion

This display system design selects battery temperature as the display parameter, which can real-time understand the temperature status of the battery. By designing the hardware and software of the temperature display system and testing it, the results show that the display system can display temperature changes in real time as the battery temperature changes.

Disclaimer (Artificial intelligence)

Option 1:

Author(s) hereby declare that NO generative AI technologies such as Large Language Models (ChatGPT, COPILOT, etc) and text-to-image generators have been used during

writing or editing of manuscripts.

Option 2:

Author(s) hereby declare that generative AI technologies such as Large Language Models, etc have been used during writing or editing of manuscripts. This explanation will include the name, version, model, and source of the generative AI technology and as well as all input prompts provided to the generative AI technology

Details of the AI usage are given below:

- 1.
- 2.
- 3.

References

[1] Susan, Gao Ruxin, Tan Xingguo Principles and Application of Single Chip Microcomputer [M]. Chengdu: University of Electronic Science and Technology Press, November 12, 2016

[2] Feng zhi Dai, Yuan Li, Guo dong You. Development of an Intelligent Assistant Robot based on Embedded RTOS[J]. Journal of Robotics, Networking and Artificial Life (JRNAL),2015,2(3).

[3] Feng Chong, Duan Xiaomin Feisikal MC9S12 (X) Development compulsory course [M]. Beijing: Beijing University of Aeronautics and Astronautics Press, 2014: 49-50

[4] Qiu Lichang, Zhang Lin Fundamentals of Electrical and Electronic Technology [M]. Guangzhou: South China University of Technology Press, March 5, 2006

[5] Zhang Jian Analysis on Battery Temperature Management System Controlled by MCU [J]. Heilongjiang Science, 2016, 7 (22): 34-36

[6] Li Qi, Liu Yu, Han Qifeng Software Development and Implementation of Embedded Unit Tester Based on MC9S12XS128 [J]. Electronic Design Engineering, 2015, 23 (01): 159-161

[7] By Tan Haoqiang C Voice Programming (5th Edition) [M]. Beijing: Tsinghua University Press, 2017:167-168

[8]Anonymous, Freescale Semiconductor; Freescale's CodeWarrior 10 Tool Suite, Based on the Eclipse Platform, Eases Embedded Software Development[J]. Computer Weekly News, 2010.

UNDER PEER REVIEW