

## Review Article

# Rebar Modeling of Variable Section Specially Shaped Columns Based on BIM——Taking L-shaped columns as an example

---

### ABSTRACT

Building Information Modeling (BIM), as a kind of digital means applied in the process of building design, construction and management, has been widely used in all aspects of construction engineering. However, BIM in the field of reinforcing steel engineering, due to the wide variety of complex shapes of reinforcing steel in the flat construction drawings, reinforcing steel modeling is inefficient and prone to errors. Therefore, with the help of the program to create a BIM model of rebar can reduce the occurrence of the above problems. In this paper, we mainly use Revit secondary development technology, with the help of C# programming language, to develop a generalized BIM model auto-generation program for reinforcement bars for different variable cross-section shaped columns. The program identifies the key nodes of the shaped column model, calculates the coordinate points of the reinforcement and completes the creation of the BIM model of the reinforcement by combining the structural requirements of the reinforcement in the building structure code and standard drawing. In addition, the program also carries out targeted algorithmic processing for the arrangement of the reinforcement in the complex variable cross-section areas of the upper and lower columns. The traditional standard column model plug-in is usually difficult to cope with complex components such as variable cross-section shaped columns rebar modeling, and this program through improved algorithms to provide a number of complex structures to efficiently create the idea of rebar, especially for the rebar in the variable cross-section at the processing of the finer, to ensure that the geometric accuracy of the rebar model.

*Keywords: BIM; Secondary development; Specially shaped column; Reinforcement BIM.*

### 1. INTRODUCTION

In recent years, with the rapid development of technology, BIM has gradually emerged as a powerful force in the modern construction industry, and many scholars are increasingly concerned about BIM. Through three-dimensional digital technology [1-3], BIM enables the integration and management of information throughout the entire lifecycle of a construction project, including design, construction, and operation phases. The combination of BIM and plan construction drawings has gradually become a trend [4,5], but due to the two-dimensional drawings contain very limited rebar information, especially for complex shaped structures, the details of its rebar can not be intuitively displayed. Therefore, applying BIM technology to 2D drawings can make rebar displayed in 3D state, which makes its presentation more intuitive and concise.

At present, BIM technology in the field of civil engineering has shown a rapid development trend, and its wide range of applications is leading a new wave of ideological change in the construction industry, and many scholars have carried out a large number of in depth and systematic research on BIM technology in their respective fields. Yang[6] propose a 3D parametric BIM modeling approach aimed at addressing the challenges of designing and constructing complex engineering structures. This method leverages parametric design to dynamically control the geometry and positioning of components within the model, enhancing precision and flexibility while minimizing design errors and construction conflicts. Kwon[7] explore a BIM-based approach for quantity take-off that simplifies the calculation of processed rebar lengths. The study examines how BIM technology can improve the accuracy and efficiency of rebar estimation, reducing material waste and optimizing construction processes. Zou[8] solved the problem of disconnection between design, fabrication and construction by using Revit and ANSYS, geometrical model conversion and accurate analysis to realize the detailed design of shaped steel structures. Madiniyeti[9] investigate the application of BIM technology for automated modeling in sluice gate projects. The research focuses on how BIM can streamline the modeling process, improve accuracy, and enhance the efficiency of designing and managing sluice gate structures. Cui[10] created a library of reusable planar modules by integrating BIM technology for more efficient use in the design and construction of prefabricated houses. Vaz[11] studied and analyzed that the integration of Revit and DesignBuilder performs best in dealing with complex geometries in complex geometries in building models, which effectively improves the efficiency of data transfer and workflow through simplified and detailed modeling. Li[12] investigated the role of BIM in building carbon flow monitoring, management and optimization to improve the accuracy and real-time performance of obtaining building carbon emission data. Zou[13] explore the integration of Design for Manufacture and Assembly (DfMA) principles with BIM and FEM technologies. The study introduces a method for converting BIM models to FEM models to enhance the detailed design of special-shaped steel structures, improving design accuracy and facilitating efficient construction. Xiao[14] proposed an automated BIM-based process that can extract relevant information from BIM and generate MEP logic chains based on predefined identification rules. Deng[15] conducted a systematic and dynamic study on the popularization process of BIM in the construction industry by constructing a System Dynamics (SD) model, which reveals the interactions and driving mechanisms between the key factors affecting the application of BIM. Khant[16] present an algorithm for generating bar bending schedules using BIM technology. The proposed method aims to improve the accuracy of bar bending schedules, which are crucial for steel reinforcement in construction, by leveraging BIM data to automate and refine the scheduling process. Sampaio[17] details the initial steps for the implementation of BIM in cultural heritage buildings, analyzing the historical evolution and identification of the building, performing data collection as well as building a hierarchical model. In addition, there are many scholars around BIM technology and 3D concrete printing[18], BIM technology and reinforced concrete repair[19], BIM technology and energy saving and emission reduction[20], BIM technology and digital twins[21] and other issues to carry out in-depth analysis.

At the same time, although there are also many scholars developing the application of BIM technology in reinforcing steel engineering or similar areas of research[22-24], but few scholars around the frame structure of variable section specially shaped columns rebar modeling to carry out in-depth discussions. So this paper is based on Revit platform, using C# programming language, Visual Studio as the development environment, using Revit secondary development technology combined with WPF forms, to develop the automatic generation program for 3D parametric modeling of rebar in variable section specially shaped columns.

## **2.METHODS**

Revit is a BIM software developed by Autodesk, which stands out in building design, construction and management by virtue of its advantages of full life cycle management, powerful collaborative work functions, parametric modeling, rich design tools and efficient document management, and its seamless integration with other Autodesk products makes it the first choice of many building professionals. Therefore, in this paper, Revit software is selected as the development object to study the reinforcement of variable section shaped columns for frame structures.

Commonly used tools for Revit secondary development include Visual Studio(VS), Revit SDK, Add-in Manager, and Revit LookUp. VS is an integrated development environment where developers write and debug code. VS provides developers with a rich programming environment that supports a variety of programming languages such as C#, VB. Revit SDK is a set of tools and resources provided by Autodesk for the development of Revit-related customized applications, plug-ins, and tools, among which it contains the Revit API development help documentation, which provides a lot of content related to the code that can help developers better understand and utilize the Revit API for secondary development. Add-In Manager is a tool for managing plug-ins in Revit, included in the Revit SDK, which allows developers to load, unload, and manage various types of plug-ins. Revit Lookup is a tool for viewing and analyzing elements and attributes in a Revit model. It provides a visual interface that allows developers to intuitively navigate and inspect various parts of a Revit model, and can help developers and users better understand and debug Revit models by viewing element details, parameter values, and associations. The Revit secondary development process is shown in Figure 1.

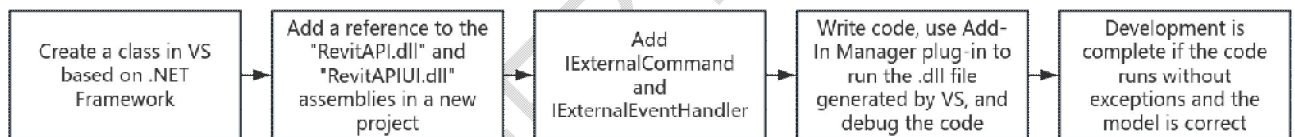

**Figure 1.** Revit secondary development process

The Revit API is an application program interface for Revit, designed to help developers programmatically interact with and extend the functionality of Revit software. It provides a powerful way for developers to extend the functionality of Revit to programmatically interact with BIM and manipulate data. By consulting the Revit API, it is known that Revit provides six static methods for generating rebar, as shown in Figure 2.

```

... public static Rebar CreateFreeForm(Document doc, RebarBarT
... public static Rebar CreateFreeForm(Document doc, RebarBarT
... public static Rebar CreateFreeForm(Document doc, Guid serv
... public static Rebar CreateFromCurves(Document doc, RebarSt
... public static Rebar CreateFromCurvesAndShape(Document doc,
... public static Rebar CreateFromRebarShape(Document doc, Reb
  
```

**Figure 2.** Rebar creation methods provided by the Revit API

At the same time, in order to improve the usability and user experience of the program, WPF (Windows Presentation Foundation) technology is used to develop a more intuitive and interactive interface. In the process of program realization, according to the relevant specifications, key parameters such as the thickness of the protective layer of concrete, the diameter type of rebar, and the height of the encrypted zone of stirrup are clearly set, and the above parameters are accurately controlled in the code. With ComboBox, all necessary parameter options are included in the form of an enumeration, thus effectively avoiding the risk of program errors due to user entered content. The WPF interaction interface is shown in Figure 3.

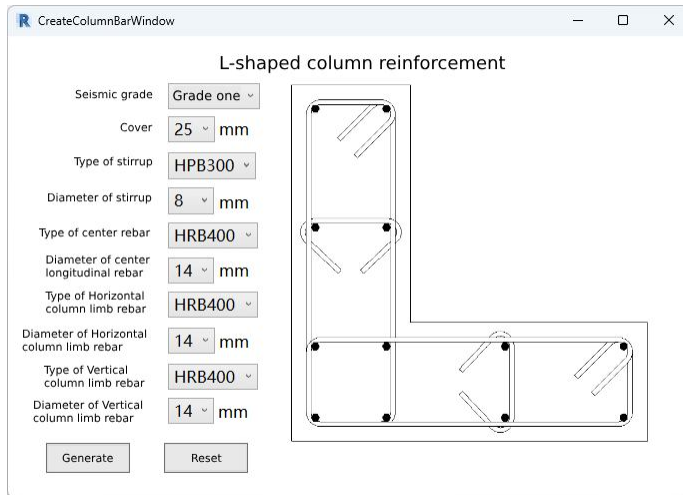

**Figure 3.** WPF interaction interface

### **3. Calculation and Generation of Rebar Models of Variable Section Specially Shaped Column**

#### **3.1 Calculation and Generation of the Longitudinal Rebar**

Article 2.1.1 of JGJ 149-2017 states that specially shaped column is a column with a cross-section geometry of L-shape, T-shape, cross-shape, Z-shape, and the ratio of limb height to limb thickness for each limb of the cross-section is not greater than four[25]. Due to the complexity of specially shaped column section, this paper will discuss in detail for the case of column variable section along the shaped column limb direction, aiming to provide ideas and references for other cases. For a more precise description, the longitudinal bars were created by subdividing them into center longitudinal rebar, column limb longitudinal rebar, and constructional rebar.

##### **3.1.1 Calculation and Generation of the Center Longitudinal Rebar**

The center of the shaped column does not involve a variable section situation, so the rebar can be set according to the standard rebar. The general idea is based on the local coordinate system of the column, calculate the coordinates of the starting point and the end point of the longitudinal rebar model, and use the `Line.CreateBound()` method to create a rebar curve according to the coordinates of the starting point and the end point, and then use the `Rebar.CreateFormCurves()` method to create a solid model based on the rebar curve.

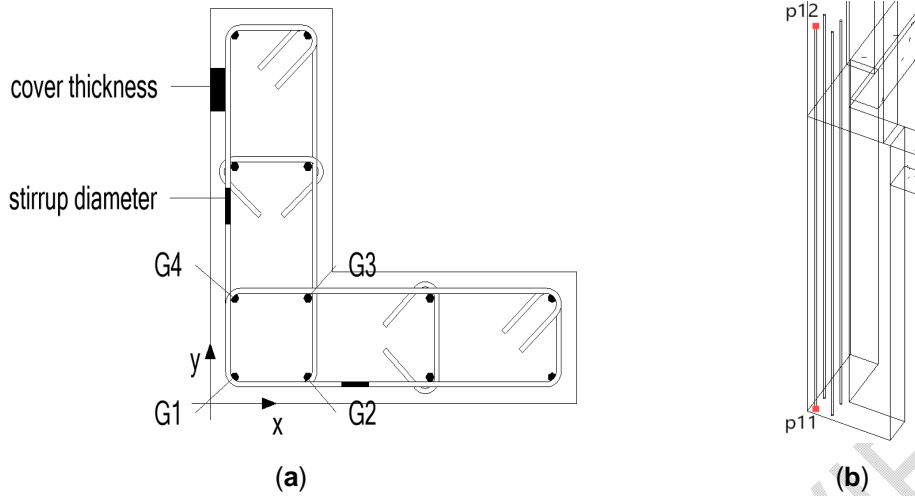

**Figure 4.** (a) Schematic diagram of center longitudinal rebar; (b) Locating points for longitudinal rebar G1

Take an L-shaped column as an example, as shown in Figure 4. Taking the longitudinal bar G1 as an example, so that the diameter of the stirrup used is  $d_s$ , the diameter of the longitudinal rebar is  $d_l$ , the thickness of the protective layer of concrete in the column is  $c$ , the height of the beam intersecting the column is  $h$ , and the height of the column is  $H$ , the length of the horizontal column limb is  $b_1$  and the thickness is  $h_1$ ; the length of the vertical column limb is  $b_2$  and the thickness is  $h_2$ , then the coordinate  $x_1$  of the starting point  $p_{11}$  of the center longitudinal rebar G1 is :

$$x_1 = c + d_s + d_l/2 \tag{1}$$

The coordinate  $y_1$  of  $p_{11}$  is:

$$y_1 = c + d_s + d_l/2 \tag{2}$$

The coordinate  $z_1$  of  $p_{11}$  is:

$$z_1 = c + d_s \tag{3}$$

As can be seen from the figure 4,  $p_{12}$  is the end point of the longitudinal rebar G1 extending into the upper column, which differs from  $p_{11}$  only in height. According to the standard design drawings of rebar connection structures can be seen, into the upper column rebar length for  $H_n/6, h_c, 500\text{mm}$  in the maximum value plus  $l_{lE}$ , where  $l_{lE}$  is the lap length, by the longitudinal tensile rebar seismic lap length table of the seismic grade and concrete strength class to determine.  $H_n$  is the clear height of the column,  $h_c$  is the dimension of the long side of the column section. Assume that the maximum value in  $H_n/6, h_c, 500\text{mm}$  is Max and the coordinate  $z_2$  of  $p_{12}$  is:

$$z_2 = H + \text{Max} + l_{lE} \tag{4}$$

At this point, the coordinate points of longitudinal rebar G1 has been calculated, and the rest of the center longitudinal rebar is calculated in a similar way. Let the distance  $d_c$  from the rebar to the edge of the concrete be:

$$d_c = c + d_s + d_l/2 \tag{5}$$

The coordinate points of the longitudinal rebar at the center of the L-shaped column are shown in Table 1:

**Table 1.** Coordinates of longitudinal rebar positioning points in the center of L-shaped column.

Number	Point	X	Y	Z
G1	p <sub>11</sub>	d <sub>c</sub>	d <sub>c</sub>	c + d <sub>s</sub>
	p <sub>12</sub>	d <sub>c</sub>	d <sub>c</sub>	H + Max + l <sub>lE</sub>
G2	p <sub>21</sub>	h <sub>2</sub> - d <sub>c</sub>	d <sub>c</sub>	c + d <sub>s</sub>
	p <sub>22</sub>	h <sub>2</sub> - d <sub>c</sub>	d <sub>c</sub>	H + Max + l <sub>lE</sub>
G3	p <sub>31</sub>	h <sub>2</sub> - d <sub>c</sub>	h <sub>1</sub> - d <sub>c</sub>	c + d <sub>s</sub>
	p <sub>32</sub>	h <sub>2</sub> - d <sub>c</sub>	h <sub>1</sub> - d <sub>c</sub>	H + Max + l <sub>lE</sub>
G4	p <sub>41</sub>	d <sub>c</sub>	h <sub>1</sub> - d <sub>c</sub>	c + d <sub>s</sub>
	p <sub>42</sub>	d <sub>c</sub>	h <sub>1</sub> - d <sub>c</sub>	H + Max + l <sub>lE</sub>

### 3.1.2 Calculation and Generation of Column Limb Longitudinal and Structural Rebar

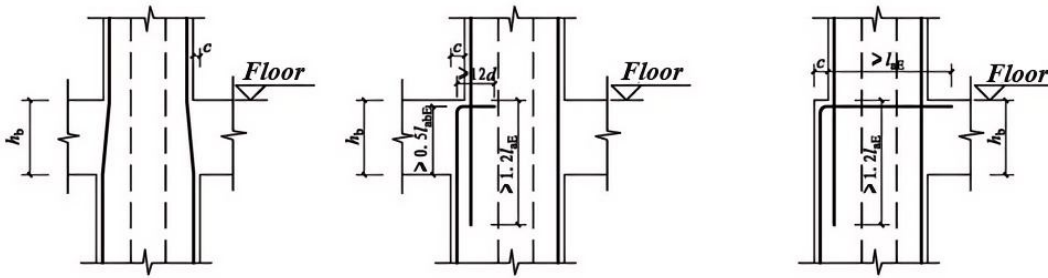

**Figure 5.** Longitudinal rebar at variable section of column

Variable section situations need to be considered at the column limb, according to the provisions of drawing set 20G331-1 for the construction of longitudinal rebar at variable section locations of columns[26], as shown in Figure 5. The column limb longitudinal rebar bends and extends to the upper column at the location where the beam intersects the specially shaped column.

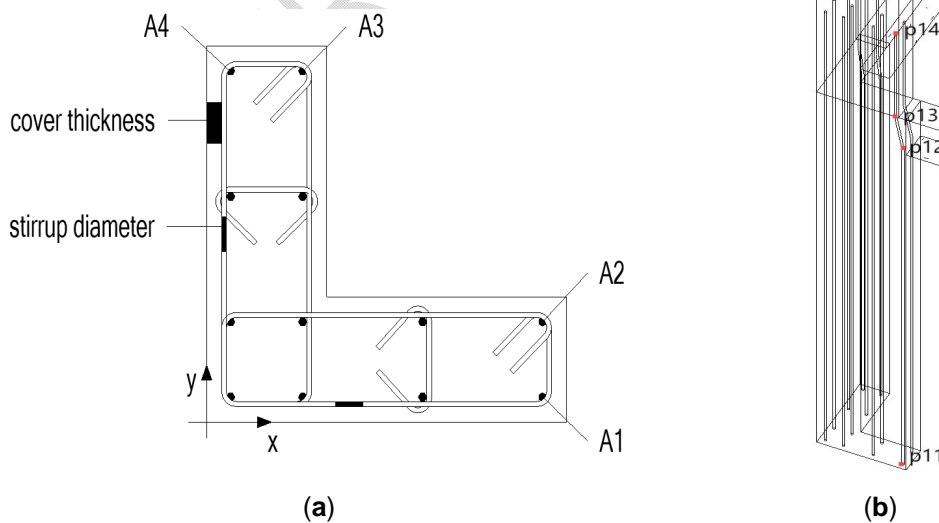

**Figure 6.**(a)Schematic diagram of column limb longitudinal rebar; (b)Locating points for longitudinal rebar A1

Four points are required for the creation of column limb longitudinal rebar, and the column limb longitudinal rebar coordinates are calculated as shown in Figure 6. Take column limb longitudinal rebar A1 as an example, the coordinate  $x_1$  of the starting point  $p_{11}$  of the longitudinal rebar A1 is:

$$x_1 = b_1 - d_c \quad (6)$$

The coordinate  $y_1$  of  $p_{11}$  is:

$$y_1 = d_c \quad (7)$$

The coordinate  $z_1$  of  $p_{11}$  is:

$$z_1 = c + d_s \quad (8)$$

As can be seen from Figure 6, the  $p_{12}$  at  $p_{11}$  in the horizontal projection of the two points coincide, so only the vertical coordinates are different, the vertical coordinates of  $p_{12}$  is the net height of the column:

$$z_2 = H_n \quad (9)$$

$p_{13}$  is at the location of the column variable cross-section, it compared to  $p_{12}$  horizontal coordinates change the upper and lower column horizontal cross-section size difference  $\Delta_{b1}$ , vertical coordinates shifted upward by  $\Delta_h$ , vertical coordinates remain unchanged, then the horizontal coordinates  $x_3$  of  $p_{13}$  is:

$$x_3 = b_1 - d_c - \Delta_{b1} \quad (10)$$

The coordinate  $z_3$  of  $p_{13}$  is:

$$z_3 = H_n + \Delta_h \quad (11)$$

$p_{14}$  is the end point of the rebar that extends into the upper column, only the vertical coordinate changes compared to  $p_{13}$ , and is calculated similarly to the end point of the longitudinal rebar at the center, so the coordinate  $z_4$  of  $p_{14}$  is:

$$z_4 = H + \text{Max} + l_{JE} \quad (12)$$

So far, the coordinate points of column limb longitudinal rebar A1 have been calculated, and the other longitudinal rebar positioning points are calculated in a similar way as above. Set the vertical column limb cross-section size difference between the upper and lower columns as  $\Delta_{b2}$ . All the longitudinal rebar coordinate points of column limbs are shown in Table 2:

**Table 2.** L-shaped column limb longitudinal rebar positioning point coordinates.

Number	Point	X	Y	Z
A1	$p_{11}$	$b_1 - d_c$	$d_c$	$c + d_s$
	$p_{12}$	$b_1 - d_c$	$d_c$	$H_n$
	$p_{13}$	$b_1 - d_c - \Delta_{b1}$	$d_c$	$H_n + \Delta_h$
	$p_{14}$	$b_1 - d_c - \Delta_{b1}$	$d_c$	$H + \text{Max} + l_{JE}$
A2	$p_{21}$	$b_1 - d_c$	$h_1 - d_c$	$c + d_s$
	$p_{22}$	$b_1 - d_c$	$h_1 - d_c$	$H_n$
	$p_{23}$	$b_1 - d_c - \Delta_{b1}$	$h_1 - d_c$	$H_n + \Delta_h$
	$p_{24}$	$b_1 - d_c - \Delta_{b1}$	$h_1 - d_c$	$H + \text{Max} + l_{JE}$
A3	$p_{31}$	$h_2 - d_c$	$b_2 - d_c$	$c + d_s$
	$p_{32}$	$h_2 - d_c$	$b_2 - d_c$	$H_n$
	$p_{33}$	$h_2 - d_c$	$b_2 - d_c - \Delta_{b2}$	$H_n + \Delta_h$
	$p_{34}$	$h_2 - d_c$	$b_2 - d_c - \Delta_{b2}$	$H + \text{Max} + l_{JE}$

A4	$p_{41}$	$d_c$	$b_2 - d_c$	$c + d_s$
	$p_{42}$	$d_c$	$b_2 - d_c$	$H_n$
	$p_{43}$	$d_c$	$b_2 - d_c - \Delta_{b2}$	$H_n + \Delta_h$
	$p_{44}$	$d_c$	$b_2 - d_c - \Delta_{b2}$	$H + \text{Max} + l_{jE}$

The third article in 6.2.3 of JGJ 149-2017 points out that the spacing of longitudinal rebar: the first, second and third level of seismic grade should not be greater than 200mm; the fourth level of seismic should not be greater than 250mm; non-seismic design should not be greater than 300mm. When the spacing of longitudinal force rebar cannot meet the above requirements, longitudinal structural rebar, whose diameter should not be less than 12mm, and tension reinforcement should be provided. The spacing of rebar should be the same as the spacing of hoop bars<sup>25</sup>. The method of calculating the coordinate points of the structural rebar is similar to that of the center longitudinal rebar, and attention should be paid to the spacing required by the specification. The coordinates of the above calculations will be used `Line.CreateBound()` method connected to a straight line, and then `Rebar.CreateFromCurves()` method for the creation of rebar. For other types of specially shaped column, the creation of longitudinal bars can be referred to L-shaped columns and will not be repeated. The generated longitudinal rebar shown in Figure 7.

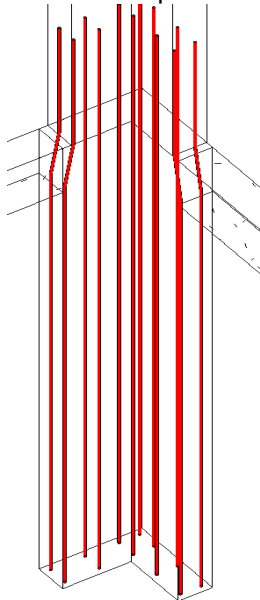

**Figure 7.** 3D view of longitudinal rebar of L-column

### 3.2 Calculation and Generation of the Stirrup

In Revit, a closed rectangular stirrup is created by connecting four coordinate points in sequence to form a closed curve, as shown in Figure 8. In the case of a closed rectangular stirrup in the encrypted zone at the top of an L-shaped column, four control points are required. In this case, the longitudinal rebar of the lower column are bent into the upper column, and each stirrup needs to be close to the bent longitudinal rebar in order to comply with the actual project.

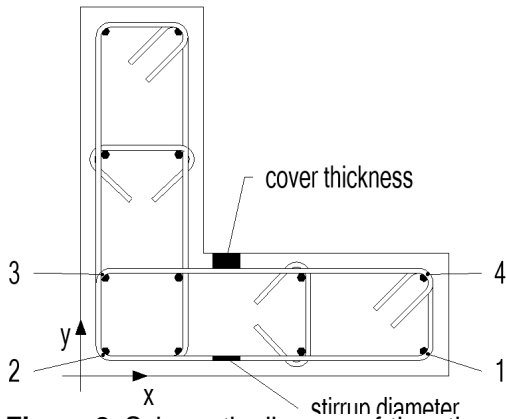
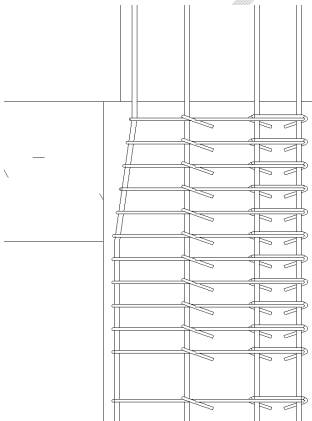

**Figure 8.** Schematic diagram of the stirrup coordinate calculation

For this kind of special stirrup generation, the general idea is to calculate the coordinate point of the uppermost single stirrup in the variable cross-section area, the corresponding coordinate point is calculated according to the thickness of the protective layer  $c$ , the diameter  $d_l$  of the longitudinal rebar and the diameter  $d_s$  of the stirrup, the rest of the stirrup in the encrypted zone in the first stirrup coordinate point is calculated, the code uses a for loop, and each time it loops in the Z coordinate changes in the encrypted zone of the stirrup maximum spacing, and the maximum spacing of the stirrup, all the stirrup can be created. The coordinate points of the uppermost single stirrup are shown in Table 3:

**Table 3.** Coordinates of locating points of the stirrup at the top of L-shaped column

Point	X	Y	Z
1	$b_1 - d_c - d_s/2 - \Delta_{b1}$	$d_c$	$H_n + \Delta_h$
2	$d_c$	$d_c$	$H_n + \Delta_h$
3	$d_c$	$h_1 - d_c - d_s/2$	$H_n + \Delta_h$
4	$b_1 - d_c - d_s/2 - \Delta_{b1}$	$h_1 - d_c - d_s/2$	$H_n + \Delta_h$



**Figure 9.** Side view of the stirrup in the variable section area of the column

As shown in Figure 9, the variation of the Z-coordinate of the horizontal column limb stirrup is affected by the maximum spacing allowed in the encrypted zone of the stirrup, whereas its X-coordinate varies accordingly with the Z-coordinate in a linear pattern, and the Y-

coordinate remains unchanged. From the maximum spacing  $S_1$  in the encrypted area of the stirrup, the difference  $\Delta_{b1}$  in cross-section dimension of the horizontal column limb of the upper and lower column, and the vertical distance  $\Delta_h$  of the variable-section rebar, it is possible to calculate the distance  $\Delta_x$  by which the X-coordinate of the stirrup is offset for each cycle of creation:

$$\Delta_x = \Delta_{b1} / (\Delta_h / S_1) \quad (13)$$

Every time stirrup is created using a for loop, the X-coordinate of the horizontal column limb stirrup will change  $\Delta_x$  to achieve the effect that the stirrup is close to the longitudinal rebar. At the same time, the X-coordinate of the stirrup cannot be shifted indefinitely, and it is necessary to limit the maximum value not to exceed the position of the longitudinal rebar with which it intersects.

The vertical column limb stirrup is created in the same way as the horizontal column limb stirrup, the only difference is that the vertical column limb stirrup is a linear variation of the Y-coordinate (X-coordinate for the horizontal column limb) with the Z-coordinate. During the creation process, refer to the method of calculating  $\Delta_x$  for the X-coordinate of the horizontal column limb stirrup, and then calculate  $\Delta_y$  for the Y-coordinate of the vertical column limb stirrup. In view of the horizontal column limb stirrup creation method has been described in detail, the vertical column limb stirrup creation process will not be repeated here. Of course, there are also non-encrypted zone stirrup in the column, and the height of the non-encrypted zone of the column can be calculated according to articles 6.2.10 and 6.2.12 of JGJ 149-2017.

For other types of specially shaped column, whether they are T-column, cross-column or Z-column, the creation of internal rebar can be referred to the calculation method similar to that of L-column, and will not be repeated. The rebar model (partial) of each specially shaped column is shown in Figure 10.

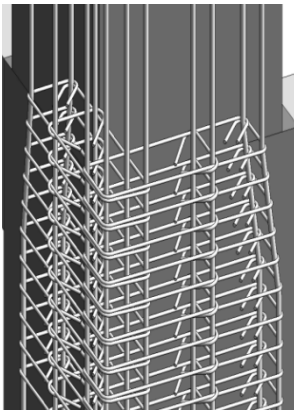

**Figure 10.** L-column stirrup 3D (partial)

## 5. Conclusions

(1) Using C# language combined with Revit API for secondary development, to standard drawing sets and specifications as a benchmark, complete the creation of rebar, and at the same time, for the stirrup creation process, for the stirrup can not be very good with the longitudinal rebar fit the problem, optimize the corresponding algorithms, to ensure that the process of creating rebar can be accurate and fast. On this basis, the rebar creation method provided by Revit API is fully utilized to analyze the differences of various types of specially shaped columns, and the automated rebar creation procedure for variable-section shaped

columns of frame structures is developed, which realizes the automation and precision of rebar creation.

(2) The XAML language is used to write the user interaction interface for the rebar reinforcement of columns, forming an intuitive WPF form, which enables the user to interact with the system more conveniently, improves the operability of the program, and realizes the automatic export of rebar quantities to improve the user's work efficiency. This study provides a reference for subsequent forward design studies.

## REFERENCES

1. Faraji, A.; Homayoon Arya, S.; Ghasemi, E.; Soleimani, H.; Rahnamayiezekavat, P. A Constructability Assessment Model Based on BIM in Urban Renewal Projects in Limited Lands. *Buildings* 2023, 13, 2599.
2. Belcher, E.J.; Abraham, Y.S. Lifecycle Applications of Building Information Modeling for Transportation Infrastructure Projects. *Buildings* 2023, 13, 2300.
3. Khattra, S.K.; Rai, H.S.; Singh, J. Towards Automated Structural Stability Design of Buildings—A BIM-Based Solution. *Buildings* 2022, 12, 451.
4. Zheng, C.; Yi, C.; Lu, M. Integrated optimization of rebar detailing design and installation planning for waste reduction and productivity improvement. *Autom. Constr.* 2019, 101, 32–47.
5. Li, S.; Shi, Y.; Hu, J.; Li, S.; Li, H.; Chen, A.; Xie, W. Application of BIM to Rebar Modeling of a Variable Section Column. *Buildings* 2023, 13, 1234.
6. Yang, L.; Gao, X.; Chen, S.; Li, Q.; Bai, S. A 3D Parameterized BIM-Modeling Method for Complex Engineering Structures in Building Construction Projects. *Buildings* 2024, 14, 1752.
7. Kwon, W.; Kim, H.; Ahn, H.; Park, U.-Y.; Kim, C.K.; Cho, H. Analysis of BIM-Based Quantity Take-Off in Simplification of the Length of Processed Rebar. *Appl. Sci.* 2023, 13, 2468.
8. Zou, Y.; Hu, F.; Yang, H.; Cai, J.; Pan, H.; Zhang, Q. Detailed Design of Special-Shaped Steel Structures Based on DfMA: The BIM-FEM Model Conversion Method. *Buildings* 2024, 14, 1320.
9. Madiniyeti, J.; Zhou, Q.; Qi, H.; Chao, Y.; Zhang, Y. Research on Automated Modeling Technology of Sluice Gate Project Based on BIM Technology. *Sensors* 2024, 24, 5114.
10. Cui, Y.; Li, S.; Liu, C.; Sun, N. Creation and Diversified Applications of Plane Module Libraries for Prefabricated Houses Based on BIM. *Sustainability* 2020, 12, 453.
11. Vaz, C.F.; Guilherme, L.L.d.F.; Maciel, A.C.F.; De Araujo, A.L.; Da Costa, B.B.F.; Haddad, A.N. Building Information Modeling/Building Energy Simulation Integration Based on Quantitative and Interpretative Interoperability Analysis. *Infrastructures* 2024, 9, 84.
12. Li, C.Z.; Deng, Y.; Ya, Y.; Tam, V.W.Y.; Lu, C. Applications of Information Technology in Building Carbon Flow. *Sustainability* 2023, 15, 16522.
13. Zou, Y.; Hu, F.; Yang, H.; Cai, J.; Pan, H.; Zhang, Q. Detailed Design of Special-Shaped Steel Structures Based on DfMA: The BIM-FEM Model Conversion Method. *Buildings* 2024, 14, 1320.
14. Xiao, Y.-Q.; Li, S.-W.; Hu, Z.-Z. Automatically Generating a MEP Logic Chain from Building Information Models with Identification Rules. *Appl. Sci.* 2019, 9, 2204.

15. Deng, J.; Li, X.; Rao, J. Research on Influencing Factors and Driving Path of BIM Application in Construction Projects Based on the SD Model in China. *Buildings* 2023, 13, 2794.
16. Khant, L.P.; Widjaja, D.D.; Kwon, K.; Kim, S. A BIM-Based Bar Bending Schedule Generation Algorithm with Enhanced Accuracy. *Buildings* 2024, 14, 1207.
17. Sampaio, A.Z.; Tomé, J.; Gomes, A.M. Heritage Building Information Modelling Implementation First Steps Applied in a Castle Building: Historic Evolution Identity, Data Collection and Stratigraphic Modelling. *Heritage* 2023, 6, 6472-6493.
18. Forcael, E.; Pérez, J.; Vásquez, Á.; García-Alvarado, R.; Orozco, F.; Sepúlveda, J. Development of Communication Protocols between BIM Elements and 3D Concrete Printing. *Appl. Sci.* 2021, 11, 7226.
19. Morgenstern, H.; Raupach, M. A Novel Approach for Maintenance and Repair of Reinforced Concrete Using Building Information Modeling with Integrated Machine-Readable Diagnosis Data. *Constr. Mater.* 2022, 2, 314-327.
20. Zhao, L.; Zhang, W.; Wang, W. BIM-Based Multi-Objective Optimization of Low-Carbon and Energy-Saving Buildings. *Sustainability* 2022, 14, 13064.
21. Sepasgozar, S.M.E.; Hui, F.K.P.; Shirowzhan, S.; Foroozanfar, M.; Yang, L.; Aye, L. Lean Practices Using Building Information Modeling (BIM) and Digital Twinning for Sustainable Construction. *Sustainability* 2021, 13, 161.
22. Wang, D.; Hu, Y. Research on the Intelligent Construction of the Rebar Project Based on BIM. *Appl. Sci.* 2022, 12, 5596.
23. Hu, J.; Bao, Q.; Zhou, T.; Li, K.; Shang, L.; Zhang, J.; Fu, X. Automatic Generation Construction Shop Design Model of the MEP Hanger Based on BIM. *Buildings* 2023, 13, 867.
24. Chen, B.; Jiang, S.; Qi, L.; Su, Y.; Mao, Y.; Wang, M.; Cha, H.S. Design and Implementation of Quantity Calculation Method Based on BIM Data. *Sustainability* 2022, 14, 7797.
25. JGJ 149-2017; Technical specification for concrete structures with specially shaped columns. China Architecture & Building Press: Beijing, China, 2017.
26. 20G331-1; Structural Construction of Concrete Shaped Columns. China Planning Press: Beijing, China, 2020.