

Impact of Chalcone on Agriculture and its Application

Abstract

Chalcones, a distinctive class of natural compounds, have garnered significant interest for their multifaceted roles in agriculture. As flavonoids, chalcones possess an open-chain structure that confers diverse biological activities, including herbicidal, fungicidal, bactericidal, and antiviral properties. With increasing concerns over synthetic pesticides' ecological and health impacts, particularly the rise in resistance among pests and weeds, there is a pressing need for sustainable alternatives. This review delves into the chemical nature, identification methods, and various applications of chalcones in agriculture. Along with the European Green Deal 2030, which aims to halve the use of chemical pesticides, chalcones are spotlighted as promising candidates for achieving these goals. Advanced analytical techniques such as chromatography and MALDI, known for their precision and reliability, are explored for their efficacy in identifying and characterizing chalcones, offering a hopeful glimpse into a more sustainable future for agriculture.

Graphical Abstract

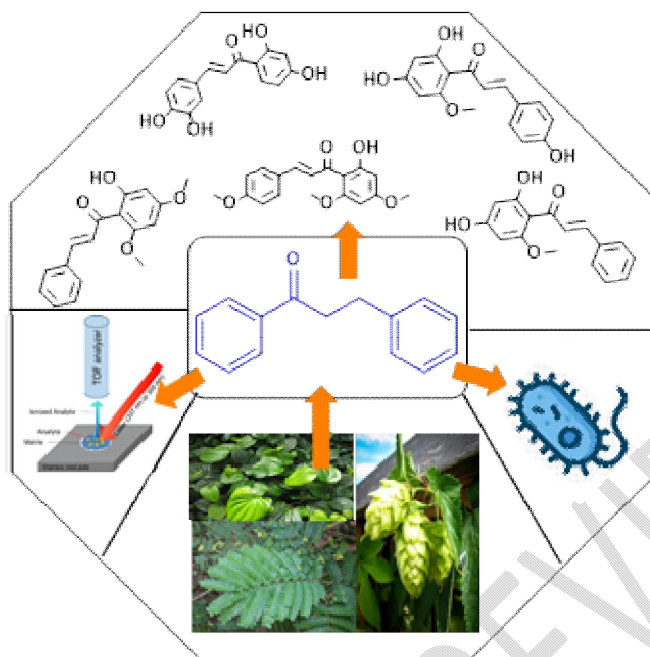

Keywords: Chalcones; Preparation Techniques; Biological Activity, Insecticidal; Herbicidal; Analysis Techniques

Introduction

Chalcones stand out from the fundamental flavonoid skeleton due to their unique structure. This distinctive design classifies them as open-chain flavonoids, as they lack the C ring found in the basic flavonoid skeleton. These compounds are significant secondary metabolites in all plant kingdoms and play a vital role in plant development and pathogen defense. A diverse family of phenolic chemicals, flavonoids are categorized into 12 groups based on the presence of methyl or hydroxyl groups on the benzene ring and their heterocyclic ring's oxidation level. Some of these subgroups include isoflavones, aurones, chalcones, dihydro-flavonols, flavanones, flavones, flavanols, leucoanthocyanidins, phlobaphenes, proanthocyanidins, and stilbenes.^{1,22,2.}

"Chalcone" is derived from the Greek word "chalcos," meaning bronze. Noteworthy chalcones include phloridzin, butein, phloretin, and chalconaringenin. These compounds are commonly found in strawberries, berries, wheat products, tomatoes, pears, apples, citrus fruits, and hops.^{9,14,54} Chalcones and their derivatives have garnered significant interest due to their extensive range of nutritional and biological activities,^{36,47} which include not just a few but a wide array of

intriguing properties such as anti-inflammatory, antitumoral, antibacterial, antifungal, antimalarial, antitubercular, and anti-pigmentation properties, often demonstrating exceptional effectiveness.^{9,14,54} Additionally, chalcones are valuable in weed control.^{14,10} Remarkably, a single compound like isobavachalcone can have multiple biological activities, including chemopreventive, anticancer, antibacterial, and antifungal properties.^{1,27} The structure of various chalcones is shown in **Figure 1**.

Historically, chalcones have been used in ancient medicine, and their naturally occurring forms are now being explored for modern applications.¹The Fork strategy of the European Union's Farm aims to reduce synthetic pesticide usage by 2030, and the demand for biopesticides is rising. Biopesticides are favored not only for their diverse modes of action but also for their improved environmental sustainability. This review provides an updated and comprehensive overview of chalcones' characteristics, properties, detection methods, and agricultural applications.

Characteristics

Chemically speaking, chalcone molecules are α , β -unsaturated ketones of two aromatic rings (rings A and B) connected by a three-carbon alkenone unit.^{23,54} The enzyme chalcone synthase (CHS, EC2.3.1.74) catalyzes the conversion of one p-coumaroyl-CoA molecule and three malonyl-CoA molecules into chalcones. In higher plants, this process synthesizes chalcones and orchestrates them. CHS is essential and significantly affects how plants grow and react to stressors, including UV rays, physical harm, herbivory, and microbial invasions.^{23,54} CHS not only promotes but also initiates the synthesis of secondary metabolites, such as phenolic compounds, in response to various stressors.

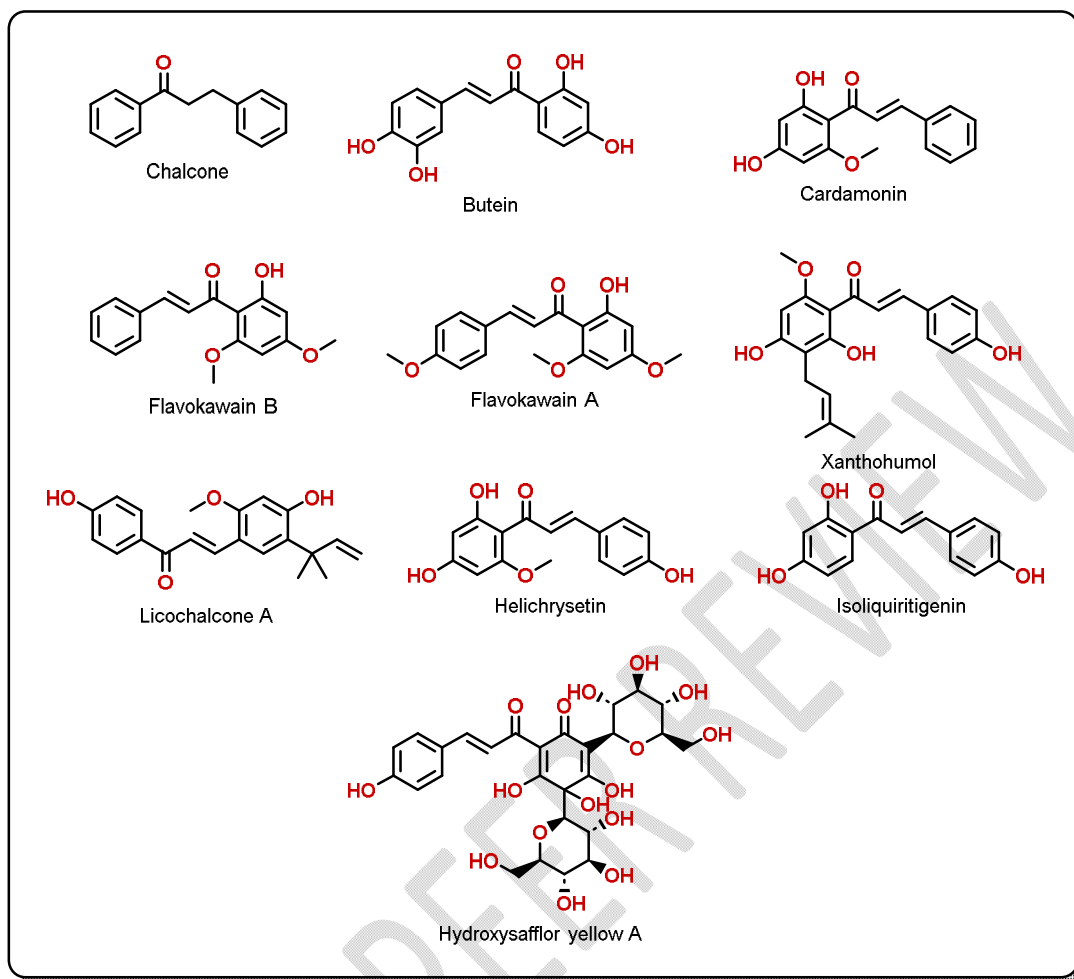

Figure 1: Chalcone and chalcone derived compounds

Although chalcones are found naturally and have a simple structural framework, several unique chalcone derivatives have been produced throughout time; bioactive chalcone derivatives have been improved for lesser toxicity by advances in synthetic chemistry,^{54,55} opening up new applications in agriculture, food production, the chemical industry, and medicine.^{39, 51} Extensive research has been conducted on synthetic chalcones since the early 1800s. For example, Kostanecki and Tambor were among the first to synthesize chalcones using alcoholic alkalis and *o*-acetoxychalcone dibromides.^{30, 54} The Claisen–Schmidt condensation with hydrochloric acid, the phosphonate carbanions synthesis, the microwave-assisted and solvent-free synthesis with biocatalysts, and the aldol condensation with hetero-aryl methyl ketones and 4-(benzyloxy) benzaldehyde are examples of standard synthetic techniques.^{27, 32, 4}

During extraction, native chalcone glycosides can convert into flavanone glycosides, which limits their presence in food.⁴⁷ For example, licorice root and some traditional medicines based on licorice have mixtures of retro chalcones, isomeric flavanones, and chalcones such as liquiritigenin and isoliquiritigenin.⁵⁰

Dihydrochalcones (DHCs), commonly found in apples and apple products, are predominantly represented by phloridzin.⁶ The concentration of DHCs is higher in the fruit peel, meaning peeled apples have fewer DHCs. Conversely, commercially produced apple juices and ciders often have 5–10 times higher DHC content because they use the whole fruit and undergo thermal treatment that deactivates the enzymes responsible for DHC degradation.⁴⁵

Preparation Techniques

Freeze-drying is one of the best techniques for sample preparation for chromatographic analysis, including UPLC-MS/MS. In this procedure, freeze-dried samples are ground for 1.5 minutes at 30 Hz using a mixer mill equipped with a zirconia bead. The resultant lyophilized powder is then dissolved in 1.2 mL of a 70% methanol solution to yield 100 mg. After six rounds of vortexing this combination for 30 seconds every 30 minutes, it is refrigerated at 4°C for the whole night. Following ten minutes of centrifugation at 12,000 rpm, the extracts are filtered, and then UPLC-MS/MS analysis is performed.⁵⁶ The crude product can be further purified using column chromatography. This method eliminates the target chemicals using a 3:1 volume ratio of petroleum ether to ethyl acetate (EtOAc).⁸

Solid-phase extraction-high-performance liquid chromatography (SPE-HPLC) is used in the pharmaceutical sector to analyze chalcones in different species and clones of *Salix*.²⁵ One gram of bark was dried and ground, then extracted for forty-five minutes at sixty degrees Celsius using three and a half milliliters of methanol. Next, at lower pressure, the mixed methanolic extracts were concentrated. For SPE, an aliquot containing 80 µL of the concentrated extract was dried off and then redissolved in 80 µL of 20% methanol.

Two new chalcone glycosides were among the bioactive chemicals the methanol recovered from the mint. The aerial components of the plant were air-dried, powdered (1000 g), and then extracted four times at 40°C using methanol.¹⁹ Following the solvent's vacuum evaporation, the

crude extract was diluted in water and separated into successive liquids using n-butanol, petroleum ether, chloroform, and ethyl acetate. A rotary evaporator evaporated each solvent layer at a lower pressure.⁹

Fructus psoralen powder was extracted using a methanol solution acidified with hydrochloric acid. The application of ultrasonication aided the extraction process. Following extraction, the mixture was centrifuged for 20 minutes at 3000 g, and the supernatant was saved for further examination.^{8,52}

Two-Dimensional High-Performance Liquid Chromatography (2D-HPLC)

Pobłocka-Olech emphasized how quickly and effectively a two-dimensional high-performance liquid chromatography (2D-HPLC) system can be used for willow bark comparison analysis(**Figure 2**). This technique used 52 reference materials in the chromatographic separation; they included salicin and catechin, as well as 29 phenolic acids and 21 flavonoids (of which there were nine flavonols, four flavones, four flavanones, two biflavones, and two chalcones). An online system was used in the separation process using a heart-cut method.^{38,41}

In the first dimension (I), a Supelcosil LC-18 column with gradient elution was used to progressively raise the methanol concentration in a methanol/water combination at a flow rate of 0.4 mL/min. In the second dimension (II), using isocratic elution with combinations of acetonitrile and water as eluents, a monolithic silica gel-packed Chromolith Performance RP18e column was utilized.^{4, 5, 6.}

Under these idealized circumstances, methanol extracts from the barks of *Salix purpurea*, *S. daphnoides* clone, and *S. sachalinensis* 'Sekka' were examined. The 2D-HPLC technology allows plant extracts to be analyzed without the need for previous purification, making finding secondary metabolites in various plant matrices possible.

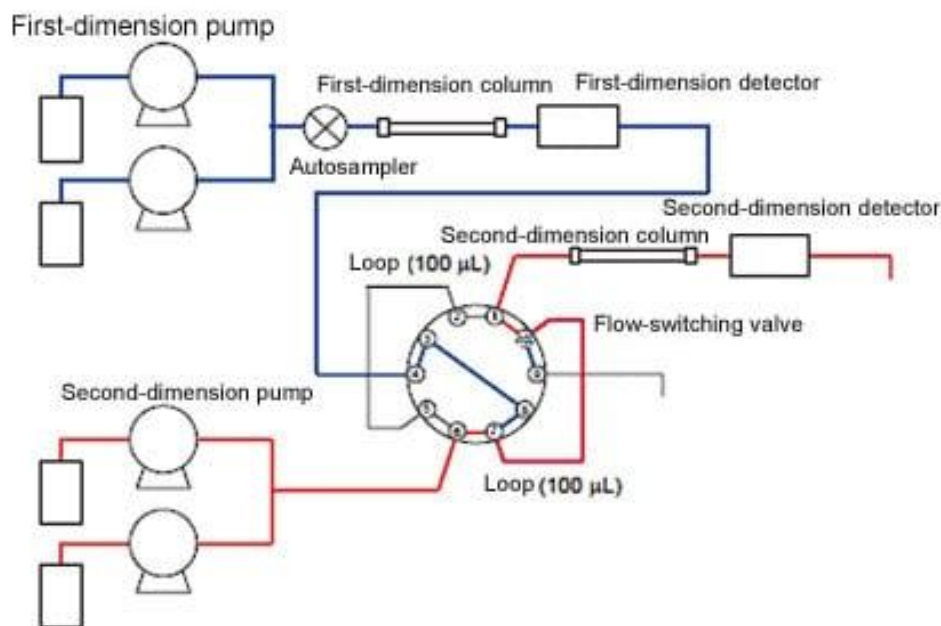

Figure 2: Two-Dimensional High-Performance Liquid Chromatography (2D-HPLC)
(Source:Shimadzu)

Infrared Spectroscopy (FTIR) and Nuclear Magnetic Resonance(NMR)

Their molecular structure reveals the unique characteristics of Chalcones' infrared (IR) spectra. The aromatic C-H bonds' symmetric and asymmetric stretching vibrations are seen in the 3120–3080 cm^{-1} and 3060–3040 cm^{-1} , each distinguished by two low-intensity bands. Furthermore, at 3030–3010 cm^{-1} , the C-H stretching band of the =C-H group is visible. The in-plane deformation of the =C-H bond manifests as a wide weak band at 1460–1430 cm^{-1} , whereas vibrations linked to the aromatic rings are assigned to bands at 1610–1570 cm^{-1} . In the enones (=C-C=O), the carbonyl stretching vibrations range from 1650 to 1685 cm^{-1} .^{9, 13, 20} Spectroscopic methods like proton nuclear magnetic resonance (^1H NMR) and Fourier transform infrared spectroscopy (FTIR) can be used to investigate the different chalcone derivatives(**Figure 3**).^{9, 13, 20}

The FTIR spectra of these derivatives, according to Hassan et al., exhibit unique peaks that are related to the C=O stretching of carbonyl chalcone at 1708 and 1712 cm^{-1} and the C=C stretching of alkenes at 1612 and 1622 cm^{-1} . Protons of the aromatic ring are found between 7.5 and 6.6 ppm, protons of the amine group between 10.7 and 10.6 ppm, and protons linked to HC-S at five ppm, according to the ^1H NMR study of derivative C. The protons of the amine group

are located at 10.5 ppm in derivative D, whereas those of the aromatic ring are found between 7.7 and 6.8 ppm, HC-S protons are at 4.8 ppm, and methyl group protons are at 2.2 ppm.^{9, 13, 20}

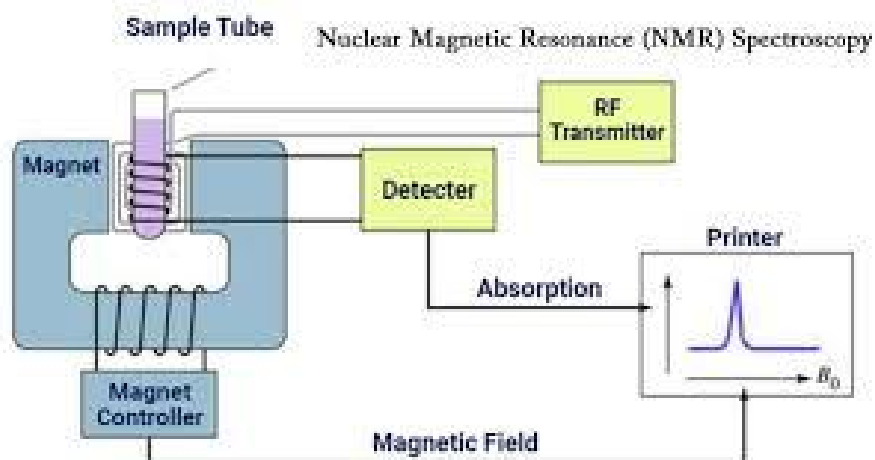

Figure 3: Nuclear Magnetic Resonance (Source: Wikipedia)

Liquid Chromatography (LC)

When examined with absorbance detectors, chalcones have two prominent absorption bands: Band I, usually observed between 340 and 390 nm, and Band II, between 220 and 270 nm. A combination of flavonoids, including naringenin, its glycosides (both (+) and (-)-5-O-glycosides), naringenin 7-O-glycoside, isosalipurposide, and its p-coumaric ester, were subjected to both qualitative and quantitative HPLC analysis.³⁸ Gradient elution was used in this research on a Discovery C18 column. Water and acetonitrile comprised the mobile phase, and orthophosphoric acid was added to balance the pH. A diode array detector (DAD) and a UV-vis detector set at 280 nm were used to expedite identification. This method was most effective with solid-phase extraction (SPE) procedures.¹³ A particular derivative of trans-chalcone, which is substituted with hydroxyl groups at the 4, 4', and 6 positions and a β -D-glucopyranosyloxy group at the 2' position, acts as both a plant metabolite and an antioxidant.²⁰

The separation of chalcones from willow tree bark using a Discovery C18 column (5 μ m, 150 \times 2.1 mm).²⁵ They used a 15-minute gradient elution with a 0.4 mL/min flow rate. Detection was performed using UV-vis DAD at 280 nm, and chalcones and flavanones were quantified through external standardization, employing isoliquiritigenin and its derivative, the 6''-O-p-coumaroyl ester, as reference standards.¹⁹

Additionally, Chen et al. conducted HPLC–UV analyses using a DL-C18 column (5.0 μm , 250 mm, and 4.6 mm) with a 0.5 mL/min flow rate. Using gradient elution, the mobile phase included acetonitrile (A) and 0.01 M formic acid (B). Detection was set at 246 nm, offering detailed insights into chalcones' chromatographic properties and related compounds.⁸

Liquid Chromatography Coupled with Mass Spectrometry (LC-MS)

Paeonia delavayi var. *lutea* extracts were examined by Zou et al. utilizing a Shimadzu UPLC-ESI-MS/MS system. An Agilent SB-C18 (1.8 μm , 2.1 \times 100 mm) UPLC column was utilized, and the mobile phase comprised acetonitrile and clean water combined with 0.1% formic acid.⁵⁶ The samples were put through a gradient program using an injection volume of 4 μL , and an ESI-triple quadrupole-linear ion trap (QTRAP)-MS was used to collect the effluent. Similar to this, Ma et al. created an internal standard (IS) of neobavaisoflavone to measure isobavachalcone (IBC) in rat plasma using selective high-performance liquid chromatography-mass spectrometry (LC-MS/MS). Isocratic elution separated the analytes on a Kinetex C18 column using acetonitrile (60:40, v/v) as the mobile phase.^{29,18,37} An electrospray ionization (ESI) source was employed, worked in the negative ion mode, and quantification was achieved through multiple reactions monitoring (MRM). This method showed good linearity within the concentration range of 3.79–484.5 ng/mL for IBC in rat plasma. Furthermore, Chen et al. detected significant constituents, including bakuchiol, bavachin, bavachinin, and isobavachalcone in *Fructus psoraleae* using HPLC coupled with UV, MS, and electrochemical detectors (ECD)(**Figure 4**). The MS analysis was conducted in negative ion mode using selected ion monitoring (SIM), offering high selectivity and sensitivity for deciding the constituents within a mass range of 50–1000 m/z.^{8,9,40.}

MALDI Technique

Krittanaï et al. reported that liquid chromatography coupled with UV detection lacks sensitivity in finding licochalcone A (LicoA), a compound commonly found in the root of Chinese licorice (*Glycyrrhiza inflata*Batalin). Consequently, they developed an enzyme-linked immunosorbent assay (ELISA) using a specific antibody to measure LicoA quantitatively. This assay showed high specificity to LicoA with minimal cross-reactivity to structurally similar substances. Upon method optimization, the detection limit was determined to be 4.32 ng/mL, with a quantification

range of 6.84–107.21 ng/mL. The newly developed assay successfully measured LicoA concentration in raw licorice and commercially available products(**Figure 5**).^{9,26}

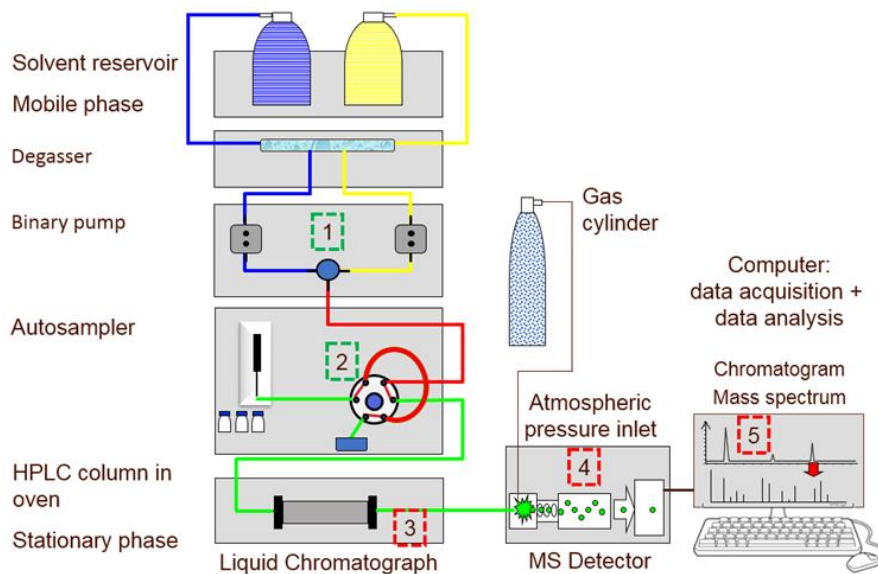

Figure 4: LC-MS (Source: Technology Networks)

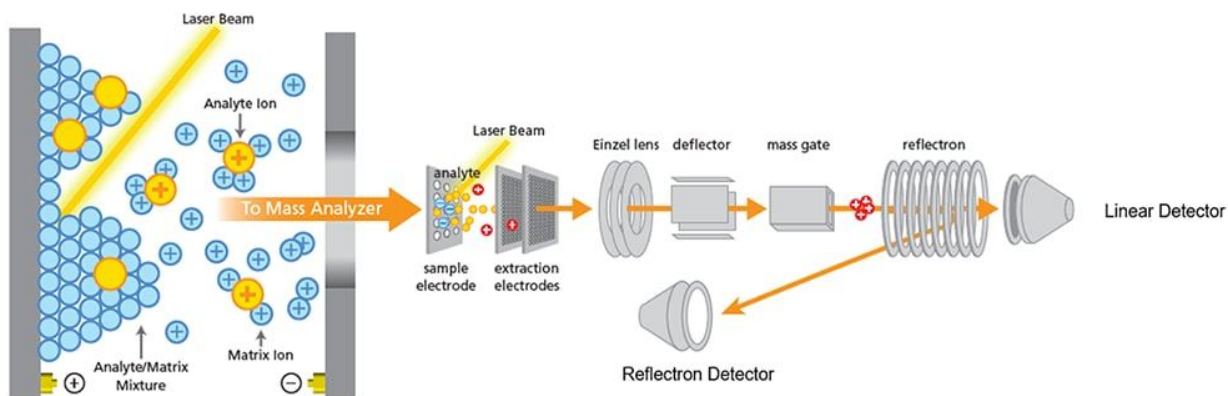

Figure 5: MALDI Technique (Source: Shimadzu)

Chalcones Biological Activities and Their Applications in Agriculture

Chalcones are multifunctional compounds widely recognized in agriculture for their pivotal role in weed and pest control. As eco-friendly pesticides, they show diverse biological effects, effectively targeting various organisms.¹⁶ The biological efficacy of chalcones hinges mainly on their structural attributes, including the arrangement of substituents such as hydroxyl groups and

the α , β double bond.^{9,1} Modifying chalcone structures by incorporating specific functional groups can enhance their desired activities, making them valuable intermediates in synthesizing therapeutically beneficial compounds.⁴⁸ Chalcones offer immense potential for agricultural applications with a spectrum of activities spanning phytotoxic, bactericidal, antifungal, antiviral, antihelmintic, insecticidal, and antifeedant properties.

Nematicides

Chalcones and their derivatives show promising nematocidal activity against plant-parasitic nematodes, including economically significant species like *Meloidogyne* spp.^{7,42,31,32} Studies have found chalcone analogs with superior nematocidal activity to commercial nematicides, offering potential alternatives for nematode control in agriculture.^{7,42} Mechanistic investigations suggest that chalcones inhibit crucial nematode enzymes, contributing to their nematocidal activity.^{7,42} Additionally, the polarity and planarity of chalcones influence their effectiveness against nematodes, highlighting the importance of structural characteristics in their nematocidal activity.^{7,42,2}

Fungicides

Chalcones are renowned for their antifungal properties against human and plant pathogens. They inhibit crucial fungal enzymes in cell wall synthesis, making them effective against various pathogens. For example, chalcones derived from *Zuccagnia punctata* have shown potent activity against soybean pathogens like *Phomopsis longicolla* and *Colletotrichum truncatum*.⁴⁶ Similarly, plant-origin chalcones have proved inhibitory effects on fungi such as *Alternaria* sp., *Fusarium* spp., and *Botrytis* sp., which cause significant agricultural losses.^{3,34} Synthetic chalcone derivatives have been developed with enhanced antifungal properties, offering promising alternatives to conventional fungicides.⁵⁴ These derivatives disrupt fungal cell membranes and inhibit fungal growth through diverse mechanisms, highlighting their potential as future fungicides.

Antiviral Agents

Chalcones and their derivatives have appeared as promising antiviral agents against various viruses, including plant viruses like the tobacco mosaic virus (TMV) and cucumber mosaic virus (CMV). Structural modifications of chalcones have led to compounds with potent antiviral

activity against TMV and CMV.^{53,17} Mechanistic studies have revealed their ability to inhibit viral replication by targeting essential viral proteins like coat proteins.⁵³ Recent research has also focused on enhancing the antiviral activity of chalcones through structural modifications, offering new avenues for combating viral infections in crops.

Insecticides

Both natural and synthetic chalcones exhibit potent insecticidal activity against a wide range of insect pests. Compounds like xanthohumol and isoxanthohumol derived from hop plants have shown significant insecticidal activity.⁴⁴ Synthetic chalcones have been synthesized and evaluated for their pesticidal properties, with structural modifications influencing their efficacy against insect pests. Mechanistic studies have elucidated the mode of action of chalcones, suggesting their potential in developing novel insecticides for pest management in agriculture.
21,12,28

In conclusion, chalcones represent a versatile class of compounds with immense potential in agriculture. Their diverse biological activities and structural modifiability make them valuable assets in developing eco-friendly pesticides, herbicides, fungicides, nematicides, and insecticides. Continued research into chalcone derivatives and their mechanisms of action holds promise for addressing agricultural challenges and ensuring sustainable crop production.

Herbicides

Chalcones are increasingly recognized for their phytotoxic properties, paving the way for developing novel herbicides. Research shows that many chalcones exhibit potent herbicidal effects while keeping low crop toxicity.^{15,16} Their activity varies based on the substituents on their structural rings A and B, the concentrations applied, and the specific plant species targeted. Derivatives holding functional groups such as phenoxyacetic acid, 4-(N, N-dimethylamino) phenyl, N-methylpyrrole, and especially thiophenyl have shown significant inhibitory effects.^{9,5,10,1} For instance, flavokawains, derivatives of xantoxylene, effectively inhibited the growth of Chinese amaranth and barnyard grass.¹⁰ Further studies have highlighted the inhibitory effects of chalcones on key plant enzymes such as coenzyme A ligase (4CL) and phosphoenolpyruvate carboxylase (PEPC), which are crucial for plant growth and metabolism.
^{33,49} Additionally, chalcones like trans-chalcone have been shown to induce programmed cell

death (PCD) in plant seedlings, suggesting their potential as plant growth regulators.³⁸ Selectivity studies have revealed differential effects of chalcones on the growth of crops and weeds, further emphasizing their potential in weed management.^{15,16} Furthermore, dihydrochalcones like phloretin have shown significant growth-retarding effects on Arabidopsis seedlings, highlighting the broad applicability of chalcones in plant growth regulation and weed control.^{43,35}

Conclusions

In summary, naturally occurring or synthetically derived chalcones are diverse and intricate compounds with many biological activities. Despite their long history, their full potential is still largely untapped and insufficiently understood, making them a focal point of ongoing scientific research. This review provides an in-depth examination of various chalcones' herbicidal, fungicidal, antiviral, insecticidal, and plant-growth regulatory properties while introducing novel detection methods based on the latest studies. Given plants limited natural production of chalcones and relatively short half-life, sourcing these compounds from nature is challenging. These hurdles have driven significant efforts toward their synthetic production and further development. Comprehensive studies are needed to clarify these reactive chalcones' mechanisms of action, confirm their effectiveness in practical agricultural applications, and evaluate their safety for the environment and human health. Addressing these areas is crucial to entirely using the potential of chalcones and ensuring their safe and effective use.

Ethics Declaration

Data availability statement

The data supporting this study's findings are available in Google Scholar at <https://scholar.google.com/>.

Because this work is a review, the data supporting the findings of this study are available online on various websites. All references (Doi) are reported in the references section. The dataset that supports the findings of this review is included in the article.

Availability of data and materials

The data was collected from various websites and search engines, such as Science Direct, Taylor and Francis, Google Scholar, etc.

References

1. Aljamali NM.; Hamzah Daylee, S.; Jaber Kadhium, A. Review on Chemical-Biological Fields of Chalcone Compounds. *Forever. J. Eng. Technol.* 2020, 2, 33–44.
2. Attar, S.; O'Brien, Z.; Alhaddad, H.; Golden, M.L.; Calderón-Urrea, A. Ferrocenyl chalcones versus organic chalcones: A comparative study of their nematocidal activity. *Bioorg. Med. Chem.* 2011, 19, 2055–2073.
3. Badaracco, P.; Sortino, M.; Pioli, R.N. Study plant-origin in compounds with potential antifungal action against pathogens of cultivated plants. *Chil. J. Agric. Anim. Sci.* 2020, 36, 244–252.
4. Balan-Porcăras, M.; Roman, G. Novel chalcone analogs derived from 4-(benzyloxy)benzaldehyde. *Ovidius Univ. Ann. Chem.* 2023, 34, 112–120.
5. Batovska, D.I.; Todorova, I.T. Trends in utilization of the pharmacological potential of chalcones. *Curr. Clin. Pharmacol.* 2010, 5, 1–29.
6. Burda, S.; Oleszek, W.; Lee, C.Y. Phenolic compounds and their apple changes during maturation and cold storage. *J. Agric. Food Chem.* 1998, 38, 945–948.
7. Cao, X.; Qiu, D.; Zhang, R.; Li, Z.; Xu, X. Synthesis, nematicidal evaluation, and SAR study of benzofuran derivatives containing 2-carbonyl thiophene. *Chin. Chem. Lett.* 2023, 34, 107800.
8. Chen, Q.; Li, Y.; Chen, Z. Separation, identification, and quantification of active constituents in *Fructus Psoraleae* by high-performance liquid chromatography with UV, ion trap mass spectrometry, and electrochemical detection. *J. Pharm. Anal.* 2012, 2, 143–151.
9. Chen, S.; Zhang, M.; Feng, S.; Gong, C.; Zhou, Y.; Xing, L.; He, B.; Wub, Y.; Xue, W. Design, synthesis and biological activity of chalcone derivatives containing pyridazine. *Arab. J. Chem.* 2023, 16, 104852.

10. Chotsaeng, N.; Laosinwattana, C.; Charoenying, P. Herbicidal Activity of Flavokawains and Related trans-Chalcones against *Amaranthus tricolor* L. and *Echinochloa crus-galli* (L.) Beauv. *ACS Omega* 2019, 4, 20748–20755.
11. Dao, T.T.; Linthorst, H.J.; Verpoorte, R. Chalcone synthase and its functions in plant resistance. *Phytochem. Rev.* 2011, 10, 397–412.
12. Devi, A.P.; Alsulimani, A.; Hidalgo, J.R.; Neske, A.; Sayyed, R.Z.; Hassan, M.; Elshazly, H. Bis- and mono-substituted Chalcones exert anti-feedant and toxic effects on fall armyworm *Spodoptera frugiperda*. *Saudi J. Biol. Sci.* 2021, 28, 5754–5759.
13. Dhaliwal, J.S.; Moshawih, S.; Goh, K.W.; Loy, M.J.; Hossain, M.S.; Hermansyah, A.; Kotra, V.; Kifli, N.; Goh, H.P.; Dhaliwal, S.K.S.; et al. Pharmacotherapeutics Applications and Chemistry of Chalcone Derivatives. *Molecules* 2022, 27, 7062.
14. Díaz-Tielas, C.; Graña, E.; Reigosa, M.J.; Sánchez-Moreiras, A.M. Biological Activities and Novel Applications of Chalcones. *Planta Daninha* 2016, 34, 607–616.
15. Díaz-Tielas, C.; Graña, E.; Sotelo, T.; Reigosa, M.J.; Sánchez-Moreiras, A.M. The natural compound trans-chalcone induces programmed cell death in *Arabidopsis thaliana* roots. *Plant Cell Environ.* 2012, 35, 1500–1517.
16. Díaz-Tielas, C.; Sotelo, T.; Graña, E.; Reigosa, M.J.; Sánchez-Moreiras, A.M. Phytotoxic potential of trans-chalcone on crop plants and model species. *J. Plant Growth Regul.* 2014, 33, 181–194.
17. Dong, L.R.; Hu, D.Y.; Wu, Z.X.; Chen, J.X.; Song, B.A. Study of the synthesis, antiviral bioactivity and interaction mechanisms of novel chalcone derivatives that contain the 1, 1-dichloropropene moiety. *Chin. Chem. Lett.* 2017, 28, 1566–1570.
18. Gupta, D.; Jain, D.K. Chalcone derivatives as potential antifungal agents: Synthesis, and antifungal activity. *J. Adv. Pharm. Technol. Res.* 2015, 6, 114–117.
19. Guvenalp, Z.; Ozbek, H.; Karadayi, M.; Gulluce, M.; Kuruuzum-Uz, A.; Salih, B.; Demirezer, O. Two antigenotoxic chalcone glycosides from *Mentha longifolia* subsp. *Longifolia*. *Pharm. Biol.* 2015, 53, 888–896.
20. Hassan, S.M.; Hassan, S.A.; Abbas, A.K.; Najem, M.R.; Jber, N.R. Synthesis of heterocyclic and study activities in agriculture as anti-dubas on date palm trees via cholinesterase inhibitors. *GSC Adv. Res. Rev.* 2023, 16, 94–101.

21. Hidalgo, J.R.; Santillán, M.; Parellada, E.A.; Khyaliya, P.; Neske, A.; Ameta, K.L. Synthetic bis-and mono-chalcones with insecticide effects on Spodoptera frugiperda (Lepidoptera: Noctuidae). *Int. J. Pest. Manag.* 2020, 66, 116–121.
22. Jash, S.K. Chemistry and Role of Flavonoids in Agriculture: A Recent Update. In *Flavonoid Metabolism-Recent Advances and Applications in Crop Breeding*; book chapter; IntechOpen: London, UK, 2022.
23. Jasim, H.A.; Nahar, L.; Jasim, M.A.; Moore, S.A.; Ritchie, K.J.; Sarker, S.D. Chalcones: Synthetic Chemistry Follows Where Nature Leads. *Biomolecules* 2021, 11, 1203.
24. Jiwrajka, M.; Phillips, A.; Butler, M.; Rossi, M.; Pocock, J.M. The plant-derived chalcone 2, 2', 5'-trihydroxychalcone provides neuroprotection against toll-like receptor 4 triggered inflammation in microglia. *Oxidative Med. Cell. Longev.* 2016, 2016, 6301712.
25. Krauze-Baranowska, M.; Poblócka-Olech, M.; Glód, D.; Wiwart, M.; Zieliński, J.; Migas, P. HPLC of Flavanones and Chalcones in different species and clones of *Salix*. *Acta Pol. Pharm.—Drug Res.* 2013, 70, 27–34.
26. Krittanai, S.; Pichetpongton, P.; Sakamoto, S.; Putalun, W. Monoclonal antibody-based immunoassay for the specific quantification of licochalcone A: An active chalcone in licorice. *Food Agric. Immunol.* 2022, 33, 220–234.
27. Kuete, V.; Sandjo, L.P. Isobavachalcone: An Overview. *Chin. J. Integr. Med.* 2012, 18, 543–547.
28. Kumar, R.; Sharma, P.; Shard, A.; Tewary, D.K.; Nadda, G.; Sinha, A.K. Chalcones as promising pesticidal agents against diamondback moth (*Plutellaxylostella*): Microwave assisted synthesis and structure-activity relationship. *Med. Chem. Res.* 2012, 21, 922–931.
29. Ma, T.; Nie, L.J.; Li, H.M.; Huo, Q.; Zhang, Y.X.; Wu, C.Z. Determination of isobavachalcone in rat plasma by LC-MS/MS and its application to a pharmacokinetic study. *J. Pharm. Biomed. Anal.* 2015, 107, 50–55.
30. Mahapatra, D.K.; Bharti, S.K.; Asati, V. Chalcone scaffolds as anti-infective agents: Structural and molecular target perspectives. *Eur. J. Med. Chem.* 2015, 101, 496–524.
31. Malhotra, B.; Onyilagha, J.C.; Bohm, B.A.; Towers GH, N.; James, D.; Harborne, J.B.; French, C.J. Inhibition of tomato ringspot virus by flavonoids. *Phytochemistry* 1996, 43, 1271–1276.

32. Morsy, N.M.; Hassan, A.S. Synthesis, reactions, and applications of chalcones: A review. *Eur. J. Chem.* 2022, 13, 241–252.
33. Nguyen, G.T.T.; Erlenkamp, G.; Jäck, O.; Küberl, A.; Bott, M.; Fiorani, F.; Gohlke, H.; Groth, G. Chalcone-based selective inhibitors of a C4 plant key enzyme as novel potential herbicides. *Sci. Rep.* 2016, 6, 27333.
34. Oleszek, M.; Pecio, Ł.; Kozachok, S.; Lachowska-Filipiuk, Z.; Oszust, K.; Frać, M. Phytochemicals of apple pomace as prospect bio-fungicide agents against mycotoxigenic fungal species—In vitro experiments. *Toxins* 2019, 11, 361.
35. Onyilagha, J.C.; Malhotra, B.; Elder, M.; French, C.J.; Towers, G.N. Comparative studies of inhibitory activities of chalcones on tomato ringspot virus (ToRSV). *Can. J. Plant Pathol.* 1997, 19, 133–137.
36. Panche, A.N.; Diwan, A.D.; Chandra, S.R. Flavonoids: An overview. *J. Nutr. Sci.* 2016, 5, e47.
37. Perera, H.; Meepagala, K.M.; Fronczek, F.R.; Cook, D.D.; Wedge, D.E.; Duke, S.O. Bioassay-Guided Isolation and Structure Elucidation of Fungicidal and Herbicidal Compounds from *Ambrosia salsola* (Asteraceae). *Molecules* 2019, 24, 835.
38. Pobłocka-Olech, L. Zastosowanie Metod Chromatograficznych w Badaniach Składu Chemicznego Kory Niektórych Gatunków i Klonów Wierzby. Ph.D. Dissertation, Medical University of Gdańsk, Gdańsk, Poland, 2006.
39. Roychoudhury, A. (Ed.) *Biology and Biotechnology of Environmental Stress Tolerance in Plants: Volume 1: Secondary Metabolites in Environmental Stress*; CRC Press: Boca Raton, FL, USA, 2023.
40. Rozmer, Z.; Perjési, P. Naturally occurring chalcones and their biological activities. *Phytochem. Rev.* 2014, 15, 87–120.
41. Shakil, N.A.; Saxena, D.B. Isolation and structure of cordifolin, a novel insecticidal oxygenated chalcone, from the stem of *Tinospora cordifolia* Miers. *Nat. Prod. Commun.* 2006, 1, 553–556.
42. Silva, F.J.; Campos, V.P.; Oliveira, D.F.; Gomes, V.A.; Barros, A.F.; Din, Z.U.; Rodrigues-Filho, E. Chalcone analogues: Synthesis, activity against *Meloidogyne incognita*, and in silico interaction with cytochrome P450. *J. Phytopathol.* 2019, 167, 197–208.

43. Smailagić, D.; Banjac, N.; Ninković, S.; Savić, J.; Cosić, T.; Peñćić, A.; Calić, D.; Bogdanović, M.; Trajković, M.; Stanišić, M. New insights into the activity of apple dihydrochalcone phloretin: Disturbance of auxin homeostasis as physiological basis of phloretin phytotoxic action. *Front. Plant Sci.* 2022, 13, 875528.
44. Stompor, M.; Dancewicz, K.; Gabrys, B.; Anioł, M. Insect antifeedant potential of xanthohumol, isoxanthohumol, and their derivatives. *J. Agric. Food Chem.* 2015, 63, 6749–6756.
45. Suañez, B.; Picinelli, A.; Moreno, J.; Mangas, J.J. Changes in phenolic composition of apple juices by HPLC with direct injection. *J. Sci. Food Agric.* 1998, 78, 461–465.
46. Svetaz, L.; Tapia, A.; López, S.N.; Furlán, R.L.; Petenatti, E.; Pioli, R.; Schmeda-Hirschmann, G.; Zacchino, S.A. Antifungal chalcones and new caffeic acid esters from *Zuccagnia punctata* acting against soybean infecting fungi. *J. Agric. Food Chem.* 2004, 52, 3297–3300.
47. Tomás-Barberán, F.A.; Clifford, M.N. Flavanones, chalcones and dihydrochalcones—Nature, occurrence and dietary burden. *J. Sci. Food Agric.* 2000, 80, 1073–1080.
48. Yerragunta, V.; Suman, D.; Anusha, V.; Patil, P.; Samhitha, T. A review on chalcones and its importance. *PharmaTutor* 2013, 1, 54–55.
49. Yun, M.S.; Chen, W.; Deng, F.; Yogo, Y. Selective growth suppression of five annual plant species by chalcone and naringenin correlates with the total amount of 4-coumarate: Coenzyme A ligase. *Weed Biol. Manag.* 2009, 9, 27–37.
50. Zeng, L.; Zhang, R.Y.; Meng, T.; Lou, Z.C. Determination of nine flavonoids and coumarins in licorice root by high-performance liquid chromatography. *J. Chromatogr.* 1990, 513, 247–254.
51. Zhang, W.; Mao, P.; Yuan Ch Zhang, Y.; Zhang, T.; Liu, Y.; Tian, J.; Xue, W. Design, synthesis and antiviral activities of chalcone derivatives containing pyrimidine. *J. Saudi Chem. Soc.* 2023, 27, 101590.
52. Zhou, B.; Xing, C. Diverse molecular targets for chalcones with varied bioactivities. *Med. Chem.* 2015, 5, 388–404.
53. Zhou, D.; Xie, D.; He, F.; Song, B.; Hu, D. Antiviral properties and interaction of novel chalcone derivatives containing a purine and benzenesulfonamide moiety. *Bioorg. Med. Chem. Lett.* 2018, 28, 2091–2097.

54. Zhou, Q.; Tang, X.; Chen, S.; Zhan, W.; Hu, D.; Zhou, R.; Sun, N.; YongJun, W.; Xue, W. Design, synthesis, and antifungal activity of novel chalcone derivatives containing a piperazine fragment. *J. Agric. Food Chem.* 2022, 70, 1029–1036.
55. Zhuang, C.; Zhang, W.; Sheng, C.; Zhang, W.; Xing, C.; Miao, Z. Chalcone: A privileged structure in medicinal chemistry. *Chem. Rev.* 2017, 117, 7762–7810.
56. Zou, H.; Han, L.; Yuan, M.; Zhang, M.; Zhou, L.; Wang, Y. Sequence Analysis and Functional Verification of the Effects of Three Key Structural Genes, PdTHC2'GT, PdCHS, and PdCHI, on the Isosalipurposide Synthesis Pathway in *Paeonia delavayi* var. *lutea*. *Int. J. Mol. Sci.* 2022, 23, 5696.

UNDER PEER REVIEW