Independent Domination Topology of the Friendship Graph and Its Line Graph

Abstract

The independent domination topology of a graph is the topology generated by the family of all independent dominating sets of a graph (11). In this paper, we explored the independent domination topology induced by the friendship graph and its corresponding line graph. Moreover, we established properties of the independent domination topology of the graphs and its cardinality. The results of this study provides a framework for understanding spatial properties of graphs on different surfaces, enabling practical applications demonstrated by real-world examples.

Keywords: Friendship Graph; Line Graph; Independent Domination Topology

2010 Mathematics Subject Classification: 53C25; 83C05; 57N16

1 Preliminaries

The field of graph theory expands the concept of topology defined on a set by introducing graph topologies, which involve considering a collection of subgraphs of a graph G that satisfy three conditions similar to the axioms of point-set topology, where it is closed under arbitrary union and finite intersection, and both G and the empty graph are in the topology. Aniyán and Naduvath (2) discussed the basic concepts of graph topology and introduced the idea of the closed graph and the closure of graph topology in a graph topological space. This shows that topology and graph theory are connected because a graph G can be seen as a topological space if paired with an appropriately defined topology. Examining graph topology merges techniques and results in graph theory and topology to explore the topological characteristics of graphs and utilize graph theory ideas to analyze topological spaces (11). Hala' (7) also studied the properties of graph topology. Some studies transform graphs into topology like (1), and graphs are constructed from a discrete topology as seen in (8) and (9). This paper investigates domination topology within the context of independent domination in the friendship graph and its corresponding line graph.

A graph $G = (V, E)$ is a finite nonempty set V of elements called *vertices*, together with a set E of two-element subsets of V called *edges*. We denote V or E by $V(G)$ or $E(G)$, respectively, to show they come from G . For some vertices x and y of G , an $x - y$ walk in G is a finite alternating sequence of vertices and edges that begins with the vertex x and ends with the vertex y . An $x - y$ walk is *closed* if $x = y$. A closed walk with no repeated vertices except for the first and last is called a *cycle* (5). The *join* $G = G_1 + G_2$ of graphs G_1 and G_2 with disjoint point sets V_1 and V_2 and edge sets X_1 and X_2 is the graph union $G_1 \cup G_2$ together with all the edges joining V_1 and V_2 (12). Two vertices that are joined by an edge are *adjacent to each other*. If two vertices are not joined by an edge, it is said that they are *nonadjacent* or *independent*. An edge between vertices u and v is said to be *incident* with v (or with u) and v is said to *dominate* u (also, u dominates v) (5). A set S of vertices in a graph G is an *independent dominating set* of G (I_G) if S is both an independent set and a dominating set of G (3).

A topology τ on a nonempty set X is a class of subsets of X that is closed under arbitrary union and finite intersection, and X and \emptyset belong to τ . The member of τ is called an *open set* and the pair (X, τ) is called a *topological space*. The topology containing all the subsets of X is called the *discrete topology* on X . Given any family $\Sigma = \{A_\alpha | \alpha \in \mathbf{A}\}$ of subsets of X , there always exists a unique, smallest topology $\tau(\Sigma) \supset \Sigma$. The family $\tau(\Sigma)$ can be described as follows: It consists of \emptyset , X , all finite intersections of A_α , and all arbitrary unions of these finite intersections. Σ is called *subbasis* for $\tau(\Sigma)$, and $\tau(\Sigma)$ is said to be generated by Σ (10).

2 Independent Domination Topology Induced by the Friendship Graph

This section discussed the construction of independent domination topology generated from the independent dominating sets of the friendship graph.

Definition 2.1. (11) Let G be a graph. The *independent domination topology* of G , denoted by $\tau_I(G)$ is the topology generated by the family I_G of all independent dominating sets (IDS) of G .

Example 2.1. Consider the graph in Figure 1 as shown below.

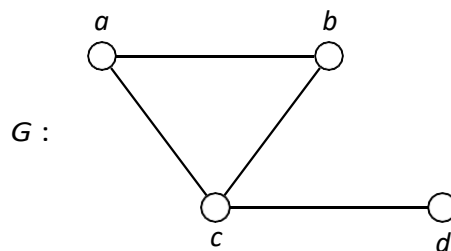

Figure 1: A Graph G

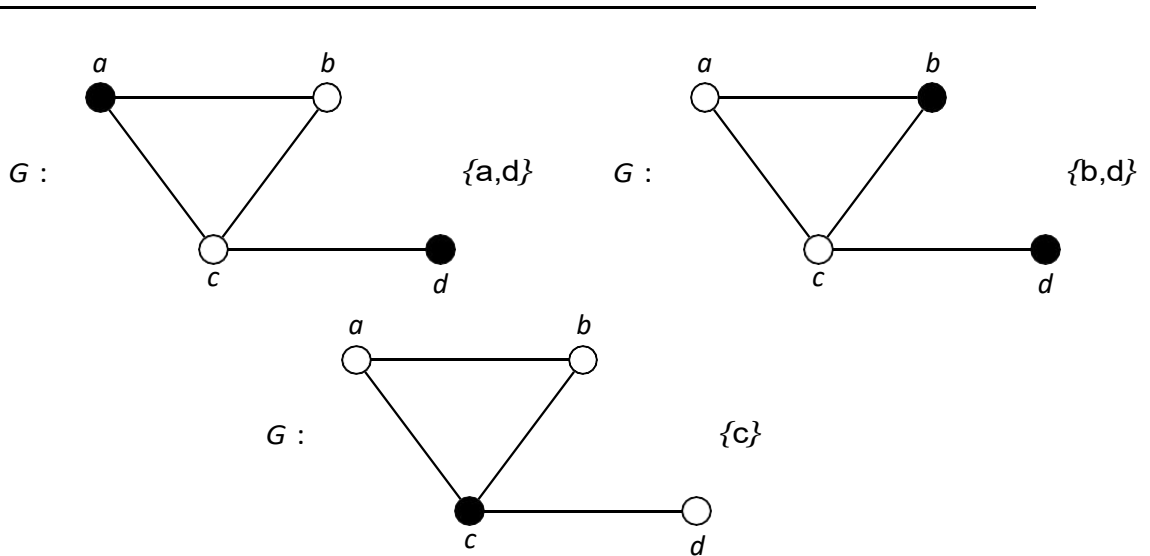

Figure 2: Independent Dominating Sets of Graph G

The set $I_G = \{\{c\}, \{a, d\}, \{b, d\}\}$ is the set of all independent dominating sets of graph G . By Definition 2.1, the topology generated by the family I_G is,

$$\tau_I(G) = \{\emptyset, V(G), \{c\}, \{a, d\}, \{b, d\}, \{d\}, \{c, a, d\}, \{c, b, d\}, \{c, d\}, \{a, b, d\}\}$$

which, therefore, is the independent dominating topology of G .

Definition 2.2. (4) A graph Fr_n with $2n + 1$ vertices and $3n$ edges is called a **friendship graph**. Friendship graphs are constructed by taking the join graph of n copies of cycle C_3 with a common vertex, where $n > 1$.

In view of Definition 2.2, we label the common vertex as v_0 , the i^{th} copy of C_3 as C_3^i , and the vertices of the i^{th} copy of C_3 as v_{ij} where $i = 1, \dots, n$ and $j = 1, 2$. Also, we let $[n] = \{1, 2, 3, \dots\}$ for $n \in \mathbb{N}$.

Example 2.2.

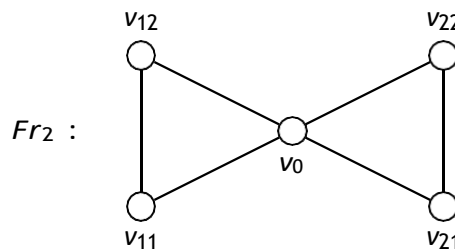

Figure 3: The Friendship Graph Fr_n where $n = 2$

Theorem 2.3. For the friendship graph Fr_n where $n \geq 2$,

$$I_{Fr_n} = \{\{v_0\}\} \cup \{\{u_1, u_2, \dots, u_n\} : u_i \in V(C_3^i) \setminus \{v_0\}\}.$$

Proof. Observe that $\{v_0\}$ is an IDS since it is a singleton and v_{ij} is adjacent to v_0 for all $i \in [n]$ and $j \in [2]$.

Let $S = \{u_1, u_2, \dots, u_n\} \subseteq V(Fr_n)$ where $u_i \in V(C_3^i) \setminus \{v_0\}$ for each $i \in [n]$. Note that for each i , the choices for u_i is either v_{i1} or v_{i2} , and u_{i_1} is not adjacent to u_{i_2} for $i_1 \neq i_2$, by definition of Fr_n . Thus, S is an independent set. Now, let $v_{ij} \in V(C_3^i)$ such that $v_{ij} \neq u_i$. Then v_{ij} is adjacent to u_i . Also, v_0 is adjacent to u_i for all $i \in [n]$. Hence, S is a dominating set. Consequently, S is an IDS.

Conversely, suppose that $S \subseteq V(Fr_n)$ such that $S \notin I_{Fr_n}$.

Case 1: $v_0 \in S$

If $v_0 \in S$ and $S \notin I_{Fr_n}$, then there exists $i \in [n], j \in [2]$ such that $v_{ij} \in S$. But v_{ij} is adjacent to v_0 , by definition of Fr_n . Thus, S is not an IDS.

Case 2: $v_0 \notin S$

If $v_0 \notin S$ and $S \notin I_{Fr_n}$, then either of the following holds:

- (i) There exists $k \in [n]$ such that $v_{k1}, v_{k2} \notin S$;
- (ii) There exists $k \in [n]$ such that $v_{k1}, v_{k2} \in S$.

In (i), S is not a dominating set since v_0 is the only vertex adjacent to both v_{k1} and v_{k2} . Also, in (ii), S is not an independent set since v_{k1} and v_{k2} are adjacent. In both cases, S is not an IDS.

Thus,

$$I_{Fr_n} = \{\{v_0\}\} \cup \{\{u_1, u_2, \dots, u_n\} : u_i \in V(C_3^i) \setminus \{v_0\}\}.$$

□

Corollary 2.4. For $n \geq 2$, $|I_{Fr_n}| = 2^n + 1$.

Proof. There are 2^n sets of the form $u_i \in V(C_3^i) \setminus \{v_0\}$ seen in Theorem 2.3. Hence, with $\{v_0\}$,

$$|I_{Fr_n}| = 2^n + 1.$$

□

Example 2.5. Consider the friendship graph Fr_3 below.

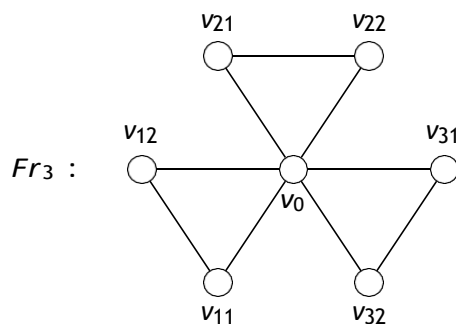

Figure 4: The Friendship Graph Fr_n where $n = 3$

The IDS of Fr_3 is $I_{Fr_3} = \{\{v_0\}, \{v_{11}, v_{21}, v_{31}\}, \{v_{11}, v_{21}, v_{32}\}, \{v_{11}, v_{22}, v_{31}\}, \{v_{11}, v_{22}, v_{32}\}, \{v_{12}, v_{21}, v_{31}\}, \{v_{12}, v_{21}, v_{32}\}, \{v_{12}, v_{22}, v_{31}\}, \{v_{12}, v_{22}, v_{32}\}\}$. As we can see,

$$\begin{aligned} |I_{Fr_3}| &= 2^n + 1 \\ &= 2^3 + 1 \\ &= 9. \end{aligned}$$

Theorem 2.6. Let $n \geq 2$. Then $\tau_I(Fr_n)$ is the discrete topology on $V(Fr_n)$.

Proof. It is sufficient to show that $\{v_0\} \in \tau_I(Fr_n)$ and for all $v_{ij} \in V(Fr_n)$, $\{v_{ij}\} \in \tau_I(Fr_n)$. By Theorem 2.2,

$$I_{Fr_n} = \{\{v_0\}\} \cup \{\{u_1, u_2, \dots, u_n\} : u_i \in V(C_3^i) \neq \{v_0\}\}.$$

Let $x \in V(Fr_n)$. If $x = v_0$, then $\{v_0\} \in \tau_I(Fr_n)$ by definition of $\tau_I(Fr_n)$. If $x \neq v_0$, then there exists $i^* \in [n]$ and $j^* \in [2]$ such that $x = v_{i^*j^*}$. Now, let

$$O_1 = \{u_1, u_2, \dots, u_{i^*}, \dots, u_n\}$$

and

$$O_2 = \{u_1, u_2, \dots, u_{i^*}, \dots, u_n\}$$

such that $u_i \neq u'_i$ for all $i \neq i^*$ and $u_{i^*} = v_{i^*j^*}$. Then $O_1, O_2 \in I_{Fr_n}$. Thus, $O_1 \cap O_2 = \{u_{i^*}\} = \{v_{i^*j^*}\} = \{x\} \in \tau_I(Fr_n)$. \square

3 Independent Domination Topology Induced by the Line Graph of the Friendship Graph

This section illustrates the line graph of Fr_n and discusses the construction of independent domination topology generated from the independent dominating sets of the line graph.

Definition 3.1. (6) The **line graph** of G , denoted $L(G)$, is the graph where the **vertices** are the **edges** of G , with two points adjacent whenever the corresponding lines of G are.

Remark 3.1. Let G be the friendship graph Fr_n . We label the edges not incident with v_0 as a_1, a_2, \dots, a_n . Furthermore, we label the edges incident with v_0 and a_i as b_{ij} for $i \in [n]$ and $j \in [2]$. By the definition of a line graph, we convert the edges of G to **vertices**, and the vertices are adjacent if and only if the corresponding edges of G have a vertex in common. Since every b_{ij} is incident with v_0 , the collection $\{b_{ij} : i \in [n], j \in [2]\}$ induces a complete graph where for each $i \in [n]$, a_i is adjacent to b_{i1} and b_{i2} .

Example 3.1.

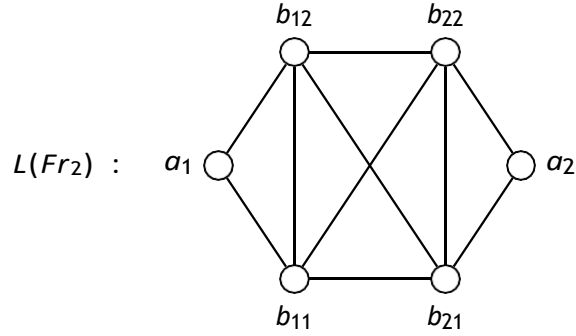

Figure 5: Line Graph of Fr_2

The following theorem considers the labelling discussed in Remark 3.1.

Theorem 3.2. Let $n \geq 2$ and $L(Fr_n)$ be the line graph of the friendship graph Fr_n . Then $S \subseteq V(L(Fr_n))$ is an independent dominating set if and only if S takes one of the following forms:

- (i) $\{a_1, a_2, \dots, a_n\}$
- (ii) $\{b_{kj}\} \cup \{a_i : i \neq k\}$ for each $k \in [n]$ and $j \in [2]$.

Proof. Let $S = \{a_1, a_2, \dots, a_n\}$. Then S is an IDS since it is independent by the definition of $L(Fr_n)$ and a_i is adjacent to b_i for every $i \in [n]$. Next, let $S = \{b_{kj}\} \cup \{a_i : i \neq k\}$. Since b_{kj} is a singleton, it is an independent set. On the other hand, $\{a_i : i \neq k\}$ is also an independent set by the definition of $L(Fr_n)$. Moreover, b_{kj} is only adjacent to a_i for each $i = k$. Thus, S is also an independent set. Now, let $x \in V(L(Fr_n)) \setminus S$. If $x = a_i$ for some $i = k$, then x is adjacent to $b_{kj} \in S$ by the definition of $L(Fr_n)$. Also, if $x = b_{ij}$ for $i \neq k$, then b_{ij} is adjacent to $a_i, i \neq k$ by the definition of $L(Fr_n)$. Hence, S is a dominating set. Consequently, S is an IDS.

Conversely, suppose that $S \subseteq V(L(Fr_n))$ such that S cannot be expressed as in (i) or (ii). If there exists $k \in [n]$ such that $a_k \notin S$, then b_{k1} and b_{k2} are not dominated by S . Also, if there exist $k \in [n]$ and $l \in [2]$ such that $b_{kl} \cup \{a_1, a_2, \dots, a_n\} \subseteq S$, then b_{kl} is adjacent to a_k . Thus, S is not an independent set. Furthermore, suppose that $b_{kj}, a_k \in S$. Then b_{kj} and a_k are adjacent. Also, if there exist $k_1, k_2 \in [n]$ such that $b_{k_1}, b_{k_2} \in S$, then they are also adjacent. Hence, S is not an independent set. So, in all cases, S is not an IDS. \square

Corollary 3.3. For $n \geq 2$, $|I_{L(Fr_n)}| = 2n + 1$.

Proof. Since every a_i is adjacent to exactly two vertices of the form b_{ij} where $i \in [n], j \in [2]$, there are $2n$ sets of the form $\{b_{kj}\} \cup \{a_i : i \neq k\}$ for each $k \in [n]$ as seen in Theorem 3.2. Hence, with $\{a_1, a_2, \dots, a_n\}$,

$$|I_{L(Fr_n)}| = 2n + 1.$$

\square

Remark 3.2. The independent domination topology of the line graph of a friendship graph $L(Fr_n)$ is not the discrete topology on $V(L(Fr_n))$. To see this, for every $i, j, \{b_{ij}\}$ cannot be $\tau_I(L(Fr_n))$ -open, since for all $k \neq i, a_k \in S_1 \cap S_2$ where S_1 and S_2 are any two IDS containing $\{b_{ij}\}$.

Theorem 3.4. For each $r \in [n], \{a_r\} \in \tau_I(L(Fr_n))$.

Proof. Let $r \in [n]$. Consider the sets $S_k = \{b_{k1}\} \cup \{a_i : i \neq k\}$ for all $k \neq r$. Then $a_r \in S_k$ for all $k \neq r$. Thus, $a_r \in \bigcap_{k \neq r} S_k$. Next, since for $k, k^* \neq r$, b_k is distinct from b_{k^*} , it follows that $\bigcap_{k \neq r} S_k$ does not contain b_k for all $k \neq r$. Now, consider a_i , $i \neq k$. It follows that $a_k \notin S_k = \{b_{k1}\} \cup \{a_i : i \neq k\}$ for all $k \neq r$. This means that $a_k \notin \bigcap_{k \neq r} S_k$. Since k is arbitrary, $\bigcap_{k \neq r} S_k = \{a_r\}$. \square

Corollary 3.5. For every subset $A \subseteq \{a_1, a_2, \dots, a_n\}$, A is $\tau_I(L(Fr_n))$ -open.

Proof. Observe that $\{a_r\} \in \tau_I(L(Fr_n))$ for each $r \in [n]$ by Theorem 3.4. By construction of the generated topology $\tau_I(L(Fr_n))$ and since $A = \bigcup_{a_r \in A} \{a_r\}$, A is $\tau_I(L(Fr_n))$ -open. \square

4 CONCLUSIONS

The independent domination topology of the friendship graph as well as its line graph have been presented in this paper. Both cardinalities of the topologies of the graphs were found. We have also determined whether the topologies were the discrete topology. Further study could focus on expanding the concept of the independent domination topology to independent domination topological graphs.

References

- [1] Alsinai, A., Dhananjayamurthy, Abdhusein, M., Idan, M., & Cancan, M. (2023). Topological Space Generated By Edges Neighborhoods of Discrete Topological Graphs. *European Chemical Bulletin*. 12. 4270-4276. 10.31838/ecb/2023.12.si6.380.
- [2] Aniyani, A., & Naduvath, S. (2023). A Study on Graph Topology. *Communications in Combinatorics and Optimization*, 8(2), 397-409. doi: 10.22049/cco.2022.27399.1253.
- [3] Chartrand, G., Lesniak, L., & Zhang, P. (2015). *Graphs & Digraphs*. (6th Edition). CRC Press.
- [4] Dharmakkan, A., Arputhamary, I., Revathi, R., & Alagar, Raja. (2022). Location Dominating Sets in Friendship Graphs. *AIP Conference Proceedings*. 2516. 210058. 10.1063/5.0109158.
- [5] Gould, R. (2013). *Graph Theory*. Courier Corporation.
- [6] Harary, F. (2018). *Graph Theory* (on Demand Printing of 02787). CRC Press.
- [7] Holá, L'ubica. (2012). The Graph Topology. *arXiv: GeneralTopology*.
- [8] Jabor, A. & Omran, A. (2019). Domination in Discrete Topology Graph. *AIP Conference Proceedings*. 2183. 030006. 10.1063/1.5136110.
- [9] Jwair, Z. N., & Abdhusein, M. A. (2023). Constructing New Topological Graph with Several Properties. *Iraqi Journal of Science*, 64(6), 2991-2999.

- [10] Macaso, J. B. & Balingit, C. (2024). The Block Topological Space and Block Topological Graph Induced by Undirected Graphs. *European Journal of Pure and Applied Mathematics*. 17. 663-675. 10.29020/nybg.ejpam.v17i2.5135.
- [11] Manla, J. (2024) Independent Domination Topological Graphs of Some Graph Families. Central Mindanao University.
- [12] Weisstein, E. W. (n.d). Graph Join. [A Wolfram Web Resource.](#)