

Original Research Article

Design and Optimization of Microstrip Antenna for 5G Wireless Applications using Genetic Algorithm

ABSTRACT

The need for small-sized communication devices has compelled designers to create antennas with compact dimensions. These antennas have to meet certain specifications, including being inexpensive, lightweight, easy to install, and built with a robust mechanical structure. In this report, two microstrip antennas operating at 28 GHz—one unoptimized and the other optimized—are designed, simulated, analyzed, and compared. The design of the unoptimized antenna was done in Ansoft HFSS, while Genetic Algorithm (GA) optimization was done in MATLAB. Results obtained make it clear how return loss, impedance bandwidth, gain, directivity, and VSWR relate to one another. The main parameters that determine the performance characteristics of the antenna are the patch width (W_p), the width (W_f) of the microstrip line, and the relative permittivity (ϵ_r) of the dielectric material under the patch. These conclusions were confirmed based on design calculations and simulated results. Findings revealed that the optimized antenna worked better at 28 GHz than the unoptimized antenna, obtaining a larger impedance bandwidth (more than 63%), a 34% higher antenna gain (7.94 dBi against 5.25 dBi), and a 35% smaller footprint. The success indicators provided in the findings have helped to achieve the objectives of the study. Furthermore, a comparison study was carried out between the recommended antennas and a few previously published research.

Keywords: Genetic Algorithm, microstrip antenna, optimization, bandwidth, communication

1. INTRODUCTION

Mobile device applications are increasingly being used in the contemporary business world leading to a sharp rise in internet traffic volume and computation needs, thereby necessitating a consequent surge in the number of mobile devices such as smartphones and laptops [1], [2]. Innovative mobile applications like interactive gaming, augmented reality, and high-definition video streaming are becoming increasingly mainstream [3]. According to [4], these applications often require low/ultra-low latency, high network bandwidth and intensive computing resources. As [5] noted, traditional mobile network architecture cannot meet such strict demands due mainly to long propagation delays. To satisfy these demands, mobile or multi-access edge computing (MEC) systems have been proposed for the fifth-generation (5G) mobile networks [6]. Ref [7] highlighted that a core requirement for adopting MEC platform is flexibility, which in turn requires that mobile wireless devices be portable, compact, lightweight and multi-application capable.

Wireless gadgets are widely used in myriad industries, including the military, telecommunications, aviation, and medical services. The increased utilization of these devices has prompted manufacturers to concentrate on enhancing wireless gadgets [8]. As a result, advancements in microwave circuit technology have been significant in recent years. The immense electronics and numerical information processing improvements made this growth possible [9]. Fundamentally, electromagnetic waves connect wireless devices to other infrastructures, simplified by antennas [10].

Antenna is one of the essential elements of wireless telecommunication systems in that they transform the electrical signal into electromagnetic signals and radiate these into space and vice versa [11]. In the recent past, [12] stated that antennas are noted to take up the most space in the communication system chain, especially at the low-frequency band; thus, increasing the antenna's total size in conformance to specific application needs makes the implementation of wireless devices difficult in small form factor [13]. Ref [14] noted in his submission that many antenna types exist with varying characteristics. However, microstrip antenna (MSA) have been reported to possess distinct features desirable to communication engineers and antenna designers [15]–[17].

In its most basic form, a microstrip patch antenna consists of a radiating patch on one side of a dielectric substrate and a ground plane on the other side [18]. The patch is generally made of a conducting material such as copper or gold and can take any possible shape, but regular shapes are generally used to simplify analysis and performance prediction [19]. The radiating patch and the feed lines are usually photo-etched on the dielectric substrate. Microstrip patches radiate due to the fringing fields between the patch edge and ground plane. Despite the desirable characteristics of MSAs, such as lightweight, conformance to mounting host, and flexibility, they possess some inherent limitations like narrow bandwidth, low power handling capability and limited antenna gain [20]–[22].

To overcome the limitation of MSAs, several methods have been proposed by many authors, such as the use of defected ground structure (DGS) by [1], the use of metamaterial by [23], the use of multiple patches by [24] and the use of artificial intelligence by [25]. Among the smart methods suggested for antenna optimization are genetic algorithm (GA) and particle swarm optimization (PSO). However, over time, designing an ideal antenna has grown more difficult and demanding due to inherent trade-offs between the selection of characteristics, including bandwidth, directivity, gain, and radiation pattern. Optimization techniques are evolving as fast as realization methods in engineering and technology.

Given the growing demand for enhanced wireless connectivity and the unique challenges posed by 5G networks, innovative microstrip patch antenna design approaches are urgently needed. This study offers an optimization approach based on GA, aiming to reduce the antenna footprint, improve overall performance and contribute significantly to the development of 5G technology.

The outline of this paper is organized as follows. Section 2 presents the review of related literature. The antenna design is presented in Section 3, and the GA-based optimization method is presented in Section 4. The simulation results and discussion are given in Section 5, and the conclusions are given in Section 6 with references used in the study appended thereafter.

2. REVIEW OF RELATED LITERATURE

Several authors have presented ideas on different approaches to optimizing and analyzing microstrip antenna for better performance. Some of these past works related to study are x-rayed in the following subsections.

Ref [26] presented the design and optimization of a microstrip antenna for millimeter wave (mmWave) 5G application at 28 GHz. The antenna was designed on an RT/Duroid 5880 substrate with a dielectric constant value of 2.2 and a loss tangent of 0.009. Results reported from simulation on Ansys HFSS show a bandwidth of 0.770 GHz, a minimum return loss of -45.23 dB, antenna gain of 6.72 dB and a VSWR of 1.01 were achieved. No external algorithm was employed in their optimization attempt.

Performance comparison of microstrip antenna designed at sub-6GHz on five different substrates (RT/Duroid 5880, FR4 glass epoxy, Taconic TLC-32, Rogers RO4003C and Bakelite) was presented by [27]. The authors reported that the FR4 antenna showed the highest bandwidth and return loss of 318.5 MHz and -31.32 dB, respectively. In comparison, the RT Duroid antenna had the highest radiation efficiency of 81% with ideal gain and directivity of 5.934 dB and 7.783 dBi, respectively. The Bakelite antenna was reported to produce the best compact dimension of 10.90×14.68 mm and a perfect match with a VSWR of 1.0. The RO4003 and TLC antennas continued to operate on average according to the authors. No optimization was reported on the antennas presented.

Ref [28] presented the design and analysis of a rectangular microstrip antenna for mmWave 5G application at 39 GHz resonance frequency. The authors employed an FR-4 glass epoxy substrate with a dielectric constant value of 4.4 and a thickness of 2 mm for their design. They reported a bandwidth of 3.5 GHz, gain of 4.23 dB, return loss of -31.87 dB, perfect feedline matching as indicated by a VSWR of 1, and radiation efficiency of 79%. The authors reported a compact design, but with a substrate thickness of 2 mm at 39 GHz, the antenna is far from being of compact geometry. No antenna optimization was reported as well.

Ref [29] proposed a performance improvement method for their designed miniaturized microstrip patch antennas loaded with a thin film of high relative permittivity material (ferroelectric material). Their proposed method involved using thin film to decrease the antenna's resonance frequency while keeping the antenna's patch dimensions constant. The authors optimized the patch dimensions in relation to frequency by adopting genetic algorithm. The resonance frequency of their microstrip patch antenna was reported to have changed from 5.8 GHz to 4.0 GHz, and the area of their proposed antenna was minimized by 42% compared to a conventional antenna alone without thin film. The authors considered only sub-6 GHz 5G antenna design and optimization.

The paper by [30] presented the antenna research community's approach to optimizing microstrip antennas using genetic algorithms (GAs). The author's literature review presented the GA optimization process, the antenna parameters optimized by GA, and the optimization goals. The evolution of GA in the context of MSAs and its importance were also examined. Several case studies supporting the application of GA optimization to broadband, multiband, high-directivity, and micro antenna design were presented, providing insight into future advancements in the field. The author only presented a review with no design case study.

In the work presented by [31], the binary coded genetic algorithm (BGA) was used to apply uniform linear arrays to a rectangular patch microstrip antenna. The microstrip array's radiation patterns before and after GA were compared, and the fitness function of GA was defined as the maximum reduction in the antenna's peak side lobe level, along with the

maximum reduction in side lobe level and the least achievable null-to-null beam width. Radiation patterns were presented for 20, 50, and 100 elements. Using MATLAB software, all of the simulated findings were produced. The authors' focus was primarily on radiation pattern augmentation.

Ref [32] proposed a microstrip antenna design for X-band application at 11 GHz frequency. The commercially available substrate material RT/duroid with height of 1.574 mm having a dielectric constant of 2.2 was used. The initial antenna designed had a patch length of 8.08 mm and a patch height of 10.77 mm. GA was applied to optimize the antenna designed to achieve high gain and directivity. The square shaped antenna with an edge size of 8.08 mm was obtained from GA-based optimization. Only antenna design and optimization for X-band application was considered in their report.

An optimized rectangular microstrip patch antenna designed on an FR-4 substrate of 4.4 relative permittivity for vehicular communication was presented by [33]. ANSYS High Frequency Structure Simulator (HFSS) based on the Finite Element Method (FEM) was used to analyze the performance of the microstrip patch antenna. Results presented showed that the antenna resonated at 5.9 GHz with a minimum return loss of -14.07 dB and VSWR of 1.13. The antenna was optimized using GA and PSO. PSO was implemented with the help of MATLAB, while GA was performed using the ANSYS optometric tool. After optimization, the return loss and VSWR obtained from GA were -34 dB and 1.0, respectively, whereas that of PSO were -20 dB and 1.65, respectively. Comparing the optimization outcomes of GA and PSO, the authors concluded that the results obtained from GA were superior to those of PSO. Only antenna design and optimization at 5.9 GHz was reported.

3. MATERIAL AND METHODS

The transmission line model equations from [14] were used to create a single-band microstrip antenna that resonates at 3.5 GHz. The rectangular patch structure functions as a resonator, therefore, its length and width are commonly chosen so that, for effective and enhanced radiation, $L_p < W_p < 2L_p$. The following is a list of the precise design equations for the rectangular microstrip patch.

i) The width (W_p) of the microstrip patch antenna computed from (1).

$$W_p = \frac{c}{2f_r \sqrt{\frac{\epsilon_r + 1}{2}}} \quad (1)$$

ii) The effective dielectric constant ($\epsilon_{r_{eff}}$) is obtained from (2).

$$\epsilon_{r_{eff}} = \frac{\epsilon_r + 1}{2} + \frac{\epsilon_r - 1}{2} \left[1 + 12 \left(\frac{h}{W_p} \right) \right]^{-1/2} \quad (2)$$

iii) The effective length L_{eff} of the patch can be derived from (3).

$$L_{eff} = \frac{c}{2f_r \sqrt{\epsilon_{r_{eff}}}} \quad (3)$$

iv) Calculation of the ground plane dimensions (L_g and W_g): The use of infinite ground planes is a key premise of the transmission line model. For practical considerations, a limited ground plane is necessary, nevertheless. The size of the ground plane for both finite and infinite ground planes is greater than the patch dimensions by around six times the substrate thickness all round [5]. Consequently, the ground plane dimensions for this design are determined as follows:

$$L_g = L_p + 6h \quad (4)$$

$$W_g = W_p + 6h \quad (5)$$

vii) Determination of the patch thickness (t): The metallic patch is selected to be very thin such that $t \ll \lambda_0$. Dielectric constant (ϵ_r) of 2.2 was used for the antenna design.

The edge feed technique was used for the feedline to the patch, and the design equations were adopted from [20], [22]. The schematic diagram and table containing computed dimensions of the 28 GHz single band patch antenna are shown in Fig. 1 and Table 1, respectively, while the designed 28GHz antenna in Ansoft HFSS is shown in Fig. 2.

Table 1: Design dimensions of 3.5 GHz single band edge fed RMSA

Design Parameter	Values
Patch dimensions:	
Length (L_p)	3.41 mm
Width (W_p)	4.24 mm
Dielectric constant (ϵ_r)	2.2
Substrate height (h)	0.34 mm
Patch thickness (t)	0.035 mm
Ground plane dimensions:	
Length of ground plane (L_g)	5.45 mm
Width of ground plane (W_g)	6.28 mm
Feed line dimensions:	
Width of quarter wave feed section (W_Q)	0.40 mm
Width of 50 Ω transmission line (W_0)	1.06 mm
Length of 50 Ω transmission line (L_0)	7.00 mm
Length of quarter wave feed line (L_Q)	1.85 mm
Input edge impedance of the patch (R_{in})	151.42 Ω
Characteristic impedance of the feed line (Z_0)	50 Ω
Characteristic impedance of quarter wave transformer (Z_1)	87.01 Ω

The geometry of the designed 28 GHz RMSA is depicted in Fig. 1.

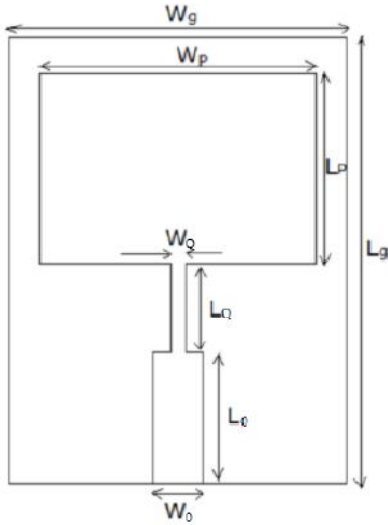

Fig. 1: Geometry of the designed antenna

The designed 28 GHz edge-fed RMSA in Ansys HFSS is shown in Fig. 2.

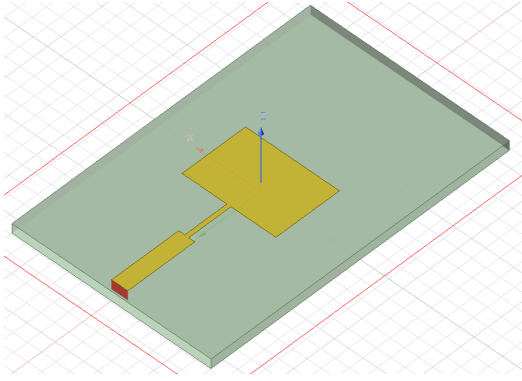

Fig. 2: 28 GHz QWT-feed Single Band MSA designed in Ansys HFSS

3.1 Microstrip Antenna Optimization Using Genetic Algorithm

The procedure used in optimising the MSA in Fig. 2 is outlined in the flowchart given in Fig. 3. The patch area is divided into $p \times k$ cells, where p is the number of rows and k is the number of columns. The conducting or non-conducting property of each cell is defined using binary encoding. If a cell is conducting, the corresponding gene is assigned 1; if a cell is non-conducting, it is assigned 0.

To apply GA, as illustrated in Fig. 3, the radiating element (patch) region is divided into $0.424 \times 0.341 \text{ mm}$ square cells, with each cell having either a conducting or non-conducting feature, the binary coding is always utilised because each cell can only have two values, hence 'on' (1)/'off' (0) states of the switches are represented by the presence or absence of a conductor, respectively. Consequently, the resulting structure comprises 40 fragment cells corresponding to a matrix of 10×10 over which a GA optimisation is run to achieve a reasonable arrangement, allowing frequency reconfiguration ability as illustrated in Fig. 4.

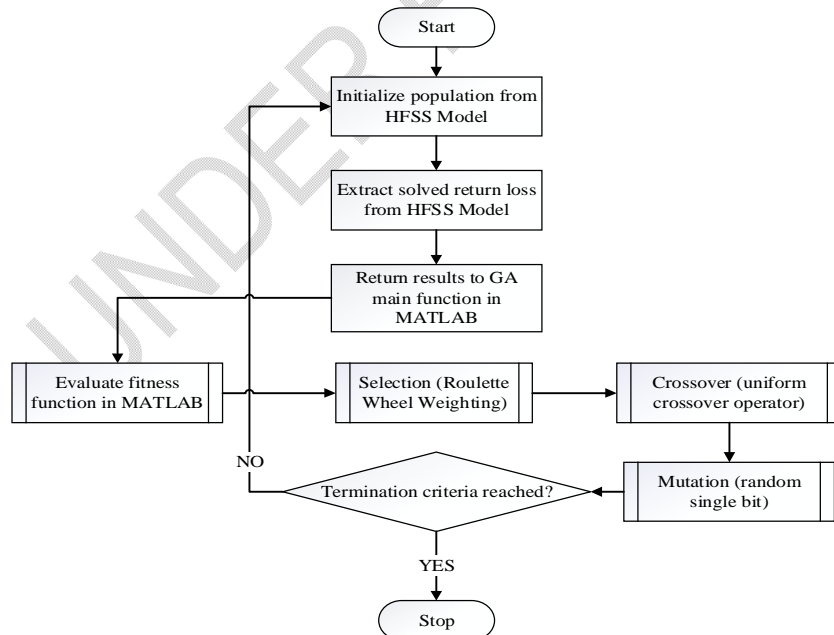

Fig. 3: GA general optimisation approach

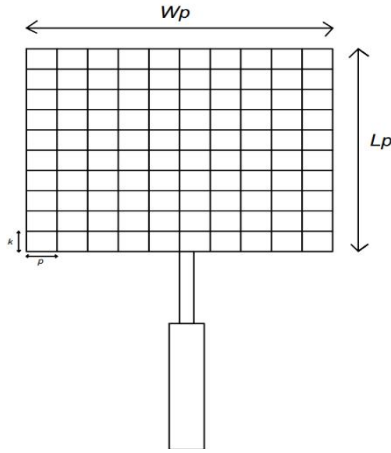

Fig. 4: Geometrical parameters on a subdivided patch surface

First, the visual basic script (VBS) environment is used to create the GA code. By changing the values of “1” for conducting pixels (cells having conductors) and “0” for non-conducting ones, it shapes the radiating element. Next, the following constraint function for the targeted bands is computed using the S_{11} parameter [34], [35]:

$$Cost = [-(12 \times BW) + S_{11(Res)}] \quad \text{Equation 3.3}$$

$$BW = \begin{cases} 5 \text{ GHz}; & \text{for } BW_{cal} \geq 5 \text{ GHz} \\ BW_{cal}; & \text{for } BW_{cal} < 5 \text{ GHz} \end{cases} \quad \text{Equation 3.4}$$

$$BW_{cal} = f_H - f_L \quad \text{Equation 3.5}$$

$$S_{11(min)} = \text{Min}[S_{11}(f_1), S_{11}(f_2), S_{11}(f_3), \dots, S_{11}(f_n)] \quad \text{Equation 3.6}$$

$$S_{11(Res)} = \begin{cases} -60 \text{ dB}; & \text{for } S_{11(min)} \leq -60 \text{ dB} \\ S_{11(min)}; & \text{for } S_{11(min)} > -60 \text{ dB} \end{cases} \quad \text{Equation 3.7}$$

where BW represents the bandwidth of the microstrip antenna determined from Equation 3.5 and S_{11} is the antenna s-parameter.

The binary string 1101011010 was used for the initial population. All the variables in their binary form are grouped into a string called a chromosome. The rest of the optimization steps are contained in the MATLAB script included in Appendix II. Table 2 gives the GA optimization setup.

Table 2: GA optimisation parameters

S/N	Parameters	Specifications
1	Number of variables	50
2	No. of Cells	100
3	Population type	Double vector
4	Selection	Roulette
5	Scaling	Rank
6	Initial penalty	10
7	Reproduction elite count	2
8	No. of generation	100
9	Crossover	Single-point
10	Crossover probability	0.7
11	Mutation	Uniform (0.01)
12	Mutation rate	0.2

4. RESULTS AND DISCUSSION

This section presents the optimized antenna geometry and its fundamental parameters, such as return loss, gain, directivity, radiation pattern, and VSWR, for detailed analysis. These parameters have been described in detail by

4.1 Geometry of Optimised Antenna

The schematic diagram showing the binary arrangement of the conductor matrix and 3D model of the GA-optimised mmWave antenna using a combination of MATLAB and Ansys HFSS are given in Figs. 5 and 6. From Fig. 5, it is imperative to note that '1' represents the presence of a conductor while '0' means no conductor, as illustrated in Fig 6.

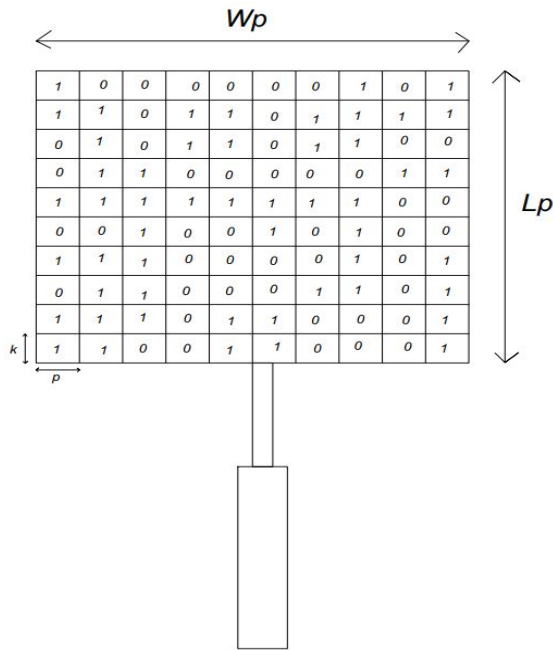

Fig. 5: Binary representation of GA-optimised antenna

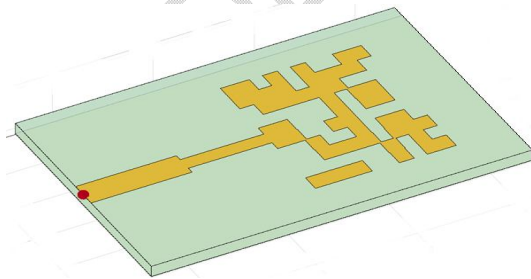

Fig. 6: 3D model of GA-optimised antenna

4.2 Return Loss Plot of Optimised Antenna

The return loss plot of the single band QWT-fed patch is presented in Fig. 7, with a minimum return loss value of -49.21 dB at 27.33 GHz. At the centre frequency of 28 GHz, the

unoptimized antenna achieved a return loss value of -31.17 dB. In contrast, the return loss of the GA-optimised antenna is presented in Fig. 8, showing a minimum return loss value of -15.83 dB.

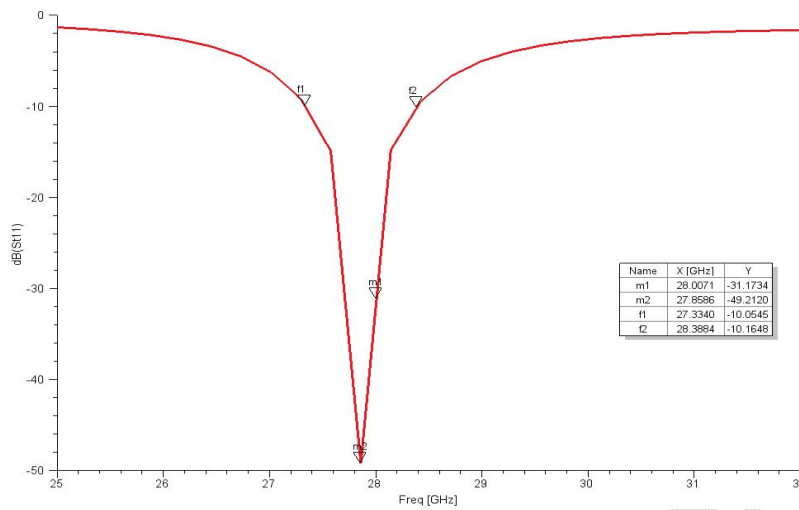

Fig. 7: Return loss plot of unoptimized QWT-fed mmWave patch antenna at 28 GHz

An impedance bandwidth of 1 GHz was achieved by the unoptimized antenna at 28 GHz, as observed in Fig. 7. Similarly, 2.404 GHz impedance bandwidth was achieved by the optimized antenna at 28 GHz, as shown in Fig. 8.

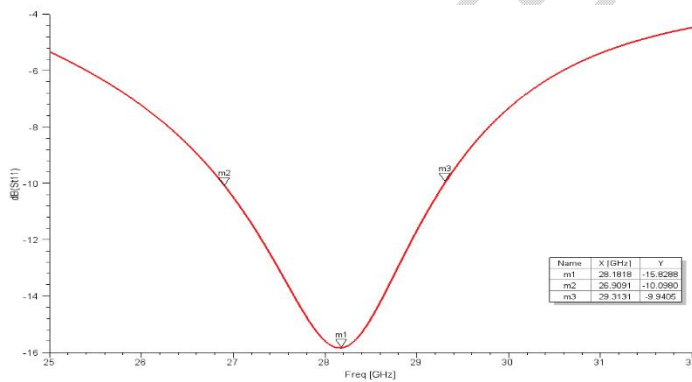

Fig. 8: Return loss plot of optimized QWT-fed mmWave patch antenna at 28

Using equations [5] to compute the fractional impedance bandwidth:

$$\text{Unoptimized 28 GHz antenna bandwidth} = \frac{28.3884 - 27.334}{28} \times 100 = 3.77\%$$

$$\text{Optimized 28 GHz antenna bandwidth} = \frac{29.3131 - 26.9091}{28} \times 100 = 8.59\%$$

The computed fractional bandwidth indicates that the optimised antenna achieved a superior bandwidth (over 63%) compared to the unoptimized antenna.

4.3 Antenna Gain

Antenna gain, in a transmitting antenna, indicates how successfully the antenna translates input power into radio waves travelling in a specific direction, while the gain of a receiving

antenna indicates how successfully it transforms incoming radio waves from a given direction into electrical power. Figs. 9 and 10 show the antenna gain of both the unoptimized and GA-optimized antennas. The antennas achieved gain values of 5.25 dBi and 7.94 dBi, respectively.

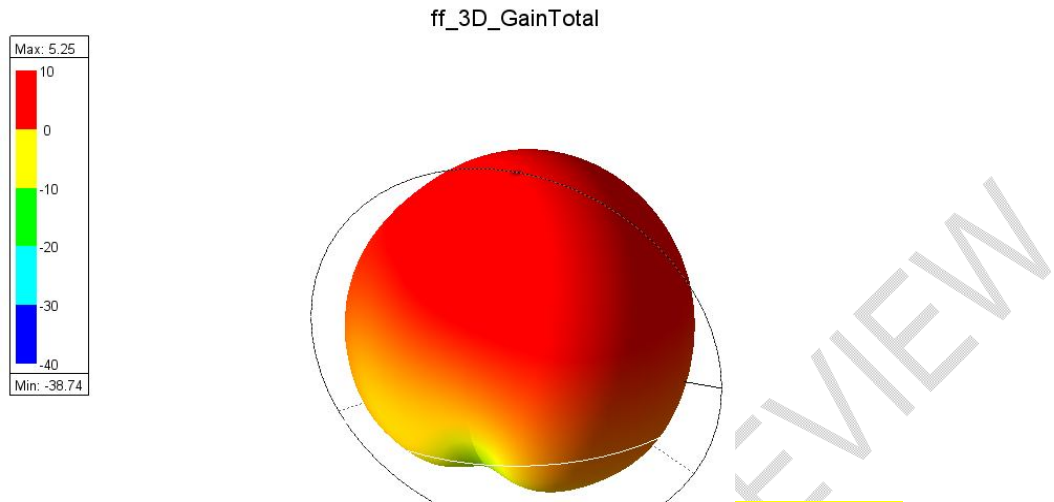

Fig. 9: Gain of unoptimized QWT-fed mmWave patch antenna at 28 GHz

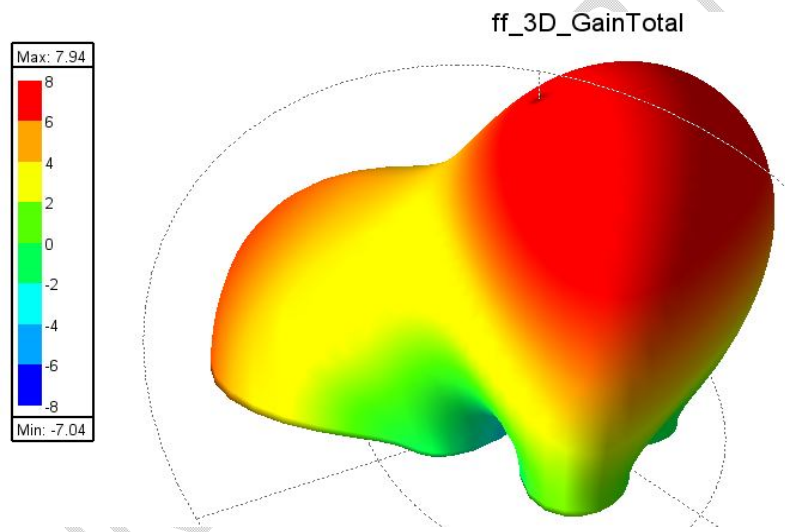

Fig. 10: Gain of GA-optimized QWT-fed mmWave patch antenna at 28 GHz

4.4 Directivity and Radiation Pattern of Designed Antennas

Directivity measures the concentration of an antenna's radiation pattern in a particular direction. The E-plane ($\varphi = 0^\circ$) and H-plane ($\varphi = 90^\circ$) directivity of the two antennas designed in Chapter Three is presented in Figs. 11 and 12. From Fig. 11, the main lobe magnitude of the unoptimized mmWave microstrip antenna is seen to be 5 dB, while that of the GA-optimized antenna is observed to be 3.6 dB, as seen in Fig. 12.

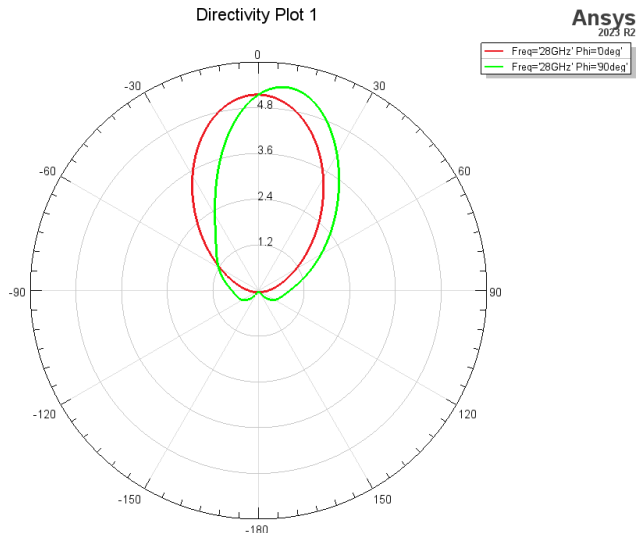

Fig. 11: E- and H-plane of the unoptimizedmmWave antenna

The radiation pattern of the unoptimized antenna is observed to be highly directed along main lobe direction of 0^0 while the optimized antenna's radiation pattern shows a broadside radiation pattern, mainly in the H-plane.

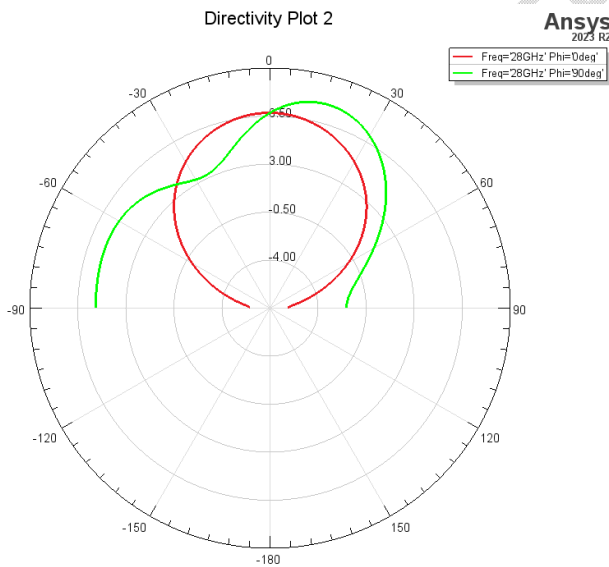

Fig. 12: E- and H-plane of the GA-optimized mmWave antenna

4.5 Voltage Standing Wave Ratio (VSWR)

Figs. 13 and 14 show the VSWRs of the two antennas studied in this report.

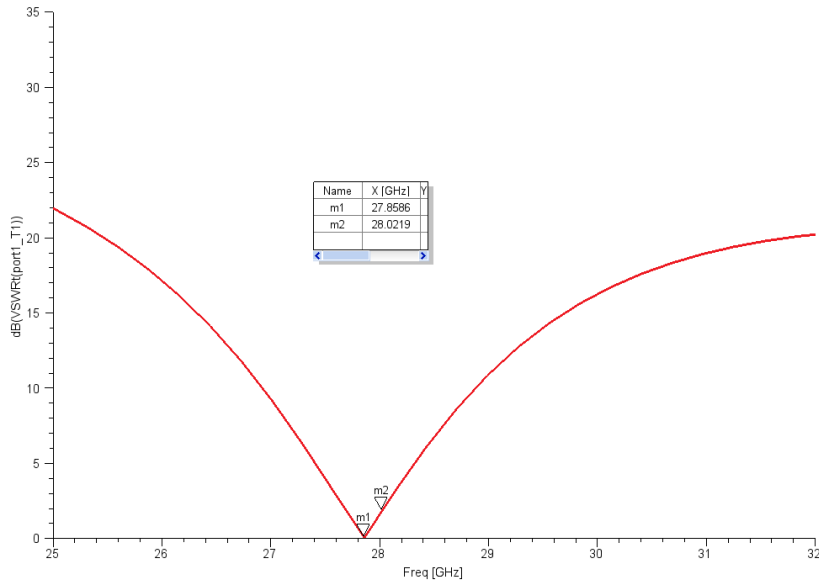

Fig. 13: VSWR of unoptimized mm-wave antenna at 28 GHz

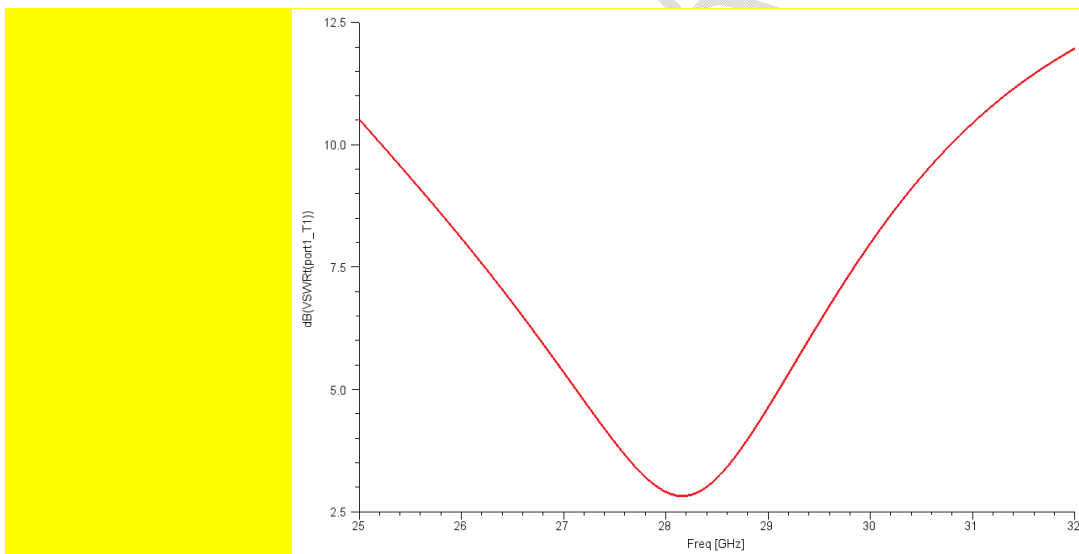

Fig. 14: VSWR of GA-optimized mm-wave antenna at 28 GHz

Figures 4.7 and 4.8 show that the unoptimized antenna achieved a VSWR of 1.734 at 28 GHz, while the GA-optimized antenna achieved a VSWR value of 2.6 at 28 GHz. Since the optimized antenna resonated beyond the reference return loss value of -10 dB, the plausible reason for the VSWR value being above 2 is that the HFSS platform adjusted the reference return loss value to -25 dB for result evaluation.

This study explored the concept of GA optimization strategy as a viable choice for mmWave antenna design at 28 GHz. A microstrip antenna was first designed at a centre frequency of 28 GHz; its parameters were studied and recorded. Furthermore, the antenna was optimised using GA, and the outcome was analysed based on antenna parameters. Results showed

that the optimised antenna achieved a higher impedance bandwidth (over 63%), 34% higher antenna gain (7.94 dBi against 5.25 dBi), and a 35% lesser footprint than the unoptimized antenna at 28 GHz. Comparing the proposed antenna to those of [35]–[39], the one proposed in this study achieved higher bandwidth and gain but underperformed in VSWR. Table 3 presents a summary of the performance metrics for the proposed GA-optimized antenna compared to some existing works.

Table 3: Performance comparison of proposed antenna with some past works

Author	Bandwidth (GHz)	Frequency (GHz)	Gain (dBi)
[26]	0.770	28	6.72
[36]	0.575	10	4.09
[37]	Nil	28	4.06
[38]	0.318	Sub-6 GHz	5.934
[39]	3.5	39	4.23
Proposed GA-optimized antenna	2.404	28	7.94

5. CONCLUSION

This paper investigated the idea of GA-based optimization to enhance the performance of a 28 GHz mmWave antenna design. First, a microstrip antenna with a 28 GHz center frequency was designed; its properties were noted and examined. In addition, GA was used to optimize the antenna with the aid of Ansys HFSS linked with MATLAB, and the results were examined in light of some antenna's fundamental parameters. Results obtained showed that the optimized antenna outperformed the unoptimized antenna at 28 GHz, achieving a greater impedance bandwidth (over 63%), a 34% higher antenna gain (7.94 dBi against 5.25 dBi), and a 35% lesser footprint.

Disclaimer (Artificial intelligence)

Option 1:

Author(s) hereby declare that NO generative AI technologies such as Large Language Models (ChatGPT, COPILOT, etc) and text-to-image generators have been used during writing or editing of manuscripts.

Option 2:

Author(s) hereby declare that generative AI technologies such as Large Language Models, etc have been used during writing or editing of manuscripts. This explanation will include the name, version, model, and source of the generative AI technology and as well as all input prompts provided to the generative AI technology

Details of the AI usage are given below:

- 1.
- 2.
- 3.

References

- [1] Abouhssous K, Wakrim I, Zugari A. and Zakriti, A.A Three-Band Patch Antenna Using a Defected Ground Structure Optimized by A Genetic Algorithm for The Modern Wireless Mobile Applications. *Jordanian J. Comput. Inf. Technol.* 2023;9(1): 11–20.
- [2] Kartz O. and Ward V. The Increased Use of Mobile Devices Expands the Threat Landscape | Akamai. *Akamai*, 2023. Accessed Dec. 25, 2023.

- Available: <https://www.akamai.com/blog/security/increased-use-mobile-devices-expands-threat-landscape>.
- [3] TRAX Analytics. Unmasking the Current Trends Revolutionizing Entertainment - Homepage. *Traxinsights*, 2023. Accessed Dec. 25, 2023.
Available: <https://traxinsights.com/2023/11/27/current-trends-in-entertainment/>.
- [4] Tardi C. What Is Moore's Law and Is It Still True? 2022.
- [5] Weni. Why mobile devices are dominating the market? 2017. Accessed Dec. 25, 2023.
Available: <https://weni.ai/en/blog/why-mobile-devices-are-dominating-the-market/>.
- [6] Duffy, C. 5G explained: What it is, who has 5G, and how much faster is it really? *CNN Business*, 2020. Accessed Oct. 12, 2023.
Available: <https://edition.cnn.com/interactive/2020/03/business/what-is-5g/#:~:text=5G is next generation wireless,new kinds of tech products>.
- [7] Sauter M. *From GSM to LTE-Advanced Pro and 5G*, Third. NJ, USA: John Wiley & Sons, Ltd, 2017.
- [8] Colaco, J. and Lohani RB. Metamaterial based multiband microstrip patch antenna for 5G wireless technology-enabled IoT devices and its applications. *J. Phys. Conf. Ser.* 2021; (2070(1)).
- [9] Viswanathan, T. *Telecommunication Switching Systems and Networks*. Prentice-Hall, New Delhi; 2006, 507.
- [10] Fang DG. *Antenna Theory and Microstrip Antennas*. New York: CRC Press, 2017.
- [11] Pozar DM. *Microwave Engineering*, 4th Edition," *John Wiley & Sons, Inc*; 2012, 1–756.
- [12] Saeidi T, Ismail I, Noghianian S, Alhawari ARH, Abbasi QH, Imran MA, Zeain MY, Ali SM. High Gain Triple-Band Metamaterial-Based Antipodal Vivaldi MIMO Antenna for 5G Communications. *Micromachines*. 2021; 12(3), 250.
- [13] Electronics Notes. What is Radio Propagation: RF Propagation. *Electronic-Notes*, 2021. Accessed Mar. 27, 2022.
Available: <https://www.electronics-notes.com/articles/antennas-propagation/propagation-overview/basics.php>.
- [14] Balanis CA. *Antenna Theory: Analysis and Design*, 4th ed. New Jersey: John Wiley & Sons, 2016.
- [15] Garg, R. *Microstrip Antenna Design Handbook*. Norwood, USA: Artech House, 2001.
- [16] Khraisat YSH. Design of 4 elements rectangular microstrip patch antenna with high gain for 2.4 GHz applications. *Mod. Appl. Sci.* 2012; 6(1):68–74.
- [17] Nag VR and Singh G. Design and Analysis of Dual Band Microstrip Patch Antenna with Microstrip feed line and slot for Multiband Application in Wireless Communication. *IRACST -International J. Comput. Sci. Inf. Technol. Secur.* 2012; 2(6):1266–1270.
- [18] Singh KK and Gupta SC. Review and Analysis of Microstrip Patch Array Antenna with different configurations. *Int. J. Sci. Eng. Res.* 2013; 4(2):1–6.
- [19] Kumar G and Ray KP. *Broadband microstrip antennas*. Artech House, 2003.
- [20] Saturday JC. Udofia KM. and Obot AB. Compact Rectangular Slot Patch Antenna for Dual Frequency Operation Using Inset Feed Technique. *Int. J. Inf. Commun. Sci.* 2017; 1(3):47–53.
- [21] Aduke AA, Obot AB and Udofia KM. Compact Dual-Band Triangular Microstrip Antenna with Broadband Characteristics for WLAN Applications," 2018; 7(79):132–136.
- [22] Obot AB, Igwue GA and Udofia KM. Design and Simulation of Rectangular Microstrip Antenna Arrays for Improved Gain Performance. *Int. J. Networks Commun.*, 2019; 9(2):73–81.
- [23] Lambert UM, Michael UK and Obot AB. Ultra-wideband Metamaterial-based Rectangular Microstrip Antenna for Sub-6 GHz 5G and other Microwave Applications. *J. Eng. Res. Reports*, 2023; 25(7):1–10.

- [24] Messaoudene I, DenidniTA and BenghaliaA. Low-profile U-shaped DRA for ultra-wideband applications.*Int. J. Microw. Wirel. Technol.*, 2016; 9(3):621–627.
- [25] JainP, MaheshwariV and ThakreVV. Micro Strip Patch Antenna Optimization Using Genetic Algorithm.*Int. J. Eng. Appl. Sci. Technol.*2016; 2(2):30–33.
- [26] EzzulddinSK, HasanSO and AmeenMM. Optimization of rectangular microstrip antenna patch parameters to operate with high radiation performances for 5G applications.*AIP Conf. Proc.*2022; 2386(2):273–286
- [27] BalaS,YunusaZ. and BabaleSA. Design and Analysis of Rectangular Microstrip Patch Antenna Using Different Dielectric Materials for Sub-6 GHz 5G Applications. *Nje*, 2021; 28(2):48-57.
- [28] KyamaR, SanapureddySD, GyadapakaJ and KhasimKNV. Design and Analysis of Microstrip Rectangular Patch Antenna for 5G Applications.*E3S Web Conf.*2023; 391, 1–9.
- [29] Boudjerda M,Reddaf A, Kacha A, Hamdi-Cherif K, Alharbi T, Alzaidi MS, Alsharef M and Ghoneim S. Design and Optimization of Miniaturized Microstrip Patch Antennas Using a Genetic Algorithm.*Electron.*, 2022; 11(14):1–14.
- [30] JayasingheJW. Application of Genetic Algorithm for Binary Optimization of Microstrip Antennas: A Review.*AIMS Electron. Electr. Eng.*2021; 5(4):315–333.
- [31] Kumari KK and SrideviPV. Sidelobe Level Optimization of Rectangular Microstrip Patch Antenna Array using Binary Coded Genetic Algorithm.*Int. J. Innov. Technol. Explor. Eng.*2020; 9(4):2053–2056.
- [32] MishraRG, MishraR, KuchhalP and KumariN. Optimization and analysis of high gain wideband microstrip patch antenna using genetic algorithm.*Int. J. Eng. Technol.*2018; 7(1):176–179.
- [33] PalniladeviP, Kalai. AK and Janani, PP. Design of an Optimized Micro-Strip Patch Antenna using Meta-Heuristic Algorithms. 2019; 3075(12):3490–3494.
- [34] LamsalliM. El-HamichiA, BoussouisM, TouhamiNA and ElhamadiTE. Genetic algorithm optimization for microstrip patch antenna miniaturization.*Prog. Electromagn. Res. Lett.*2016; 60, 113–120.
- [35] MishraRG,MishraR, KuchhalP and KumariNP.Analysis of the microstrip patch antenna designed using Genetic Algorithm based optimization for wide-band applications.*Int. J. Pure Appl. Math.*2018; 118 (11):841–849.
- [36] MagajiYR, SulaimanYY,BabangidaMM,MustaphaMG and MuhammadSA. Improved Design of Compact Microstrip Patch Antenna for Future 5G Applications.*Int. J. Adv. Acad. Res. | Sci.*, 2018; 4(7):2488–9849.
- [37] Kothari N and S. Sharma S. A 28-GHz U-slot Microstrip Patch Antenna for 5G Applications.*Int. J. Eng. Dev. Res.* 2018; 6 (1), 363.
- [38] Bala, S., Yunusa, Z., and Babale, S. A. Design and Analysis of Rectangular Microstrip Patch Antenna Using Different Dielectric Materials for Sub-6 GHz 5G Applications. *Nigerian Journal of Engineering*. 2021; 28(2), 48 – 57.
- [39] Kyama, R., Sanapureddy, S. D., Gyadapaka, J., and Khasim, K. N. V. Design and Analysis of Microstrip Rectangular Patch Antenna for 5G Applications. *Excellence in Environmental Engineering and Science (E3S) Web of Conferences*. 2023; 391, 1–9.