

Flexural Strength and Deformations Capacity of Structural Beams Reinforced with Steel Bars Milled from Recycled Metals in Ghana.

Abstract

Steel is extensively used as a reinforcing material for concrete structures in Ghana. To meet this high demand, some local steel manufacturing companies use recycled scrap metals to manufacture steel bars to augment the quantity that is imported. However, the physical and mechanical qualities of these reinforcing bars have recently been criticized by practitioners in the construction industry. This research assessed the strength and deformation behavior of milled steel reinforcing bars locally manufactured in Ghana. Reinforcing steel bars from three local milling companies, randomly categorized herein as STSL, B5PL, and FBML were selected to evaluate their strength and deformation characteristics in structural concrete beams. Similar tests were also conducted on imported standard bars categorized herein as AM. The results indicated that beams reinforced with AM bars under monotonic loading resisted the highest experimental failure loads (approximately 65 KN on average) as compared with beams reinforced with locally manufactured bars. This was attributed to the high tensile properties of AM reinforcing bars (497 N/mm² strength and 763 N/mm² maximum). The cracking loads of the AM-reinforced beams also averaged 10.5 KN and ranked high together with the FBML and B5PL-reinforced beams. The B5PL-reinforced beams failure load ranked next with an average of 56 KN, followed by FBML with 47 KN and the lowest value of 38.5 KN was in STSL beams. The average cracking load was similar for AM, FBML, and B5PL-reinforced beams with a value of approximately 10.5 KN, but the STSL-reinforced beams had the lowest cracking load averaging 5.5 KN. The impressive performance of B5PL-reinforced beams among the three locally manufactured reinforcements could be attributed to their higher yield strength, higher rib height, and comparatively smaller rib spacing. This also showed in the strong resistance of B5PL to deflection as compared to the other two locally manufactured reinforcements. Under cyclic loading, AM reinforcements again recorded the highest cracking load (7.5 KN average) and average failure load (93 KN) owing to its high tensile strength. Regarding the three locally manufactured reinforcing bars, the B5PL-reinforced beam again recorded the highest experimental failure load (55 KN average), followed by FBML-reinforced beams (54 KN on average) with beams

reinforced with STSL again recording the least (41 KN).

Keywords: *Reinforcing steel bar, scrap metals, compressive strength, tensile strength, cracking load, failure load, deflection.*

UNDER PEER REVIEW

1.0 INTRODUCTION

The high tensile strength capacity and ductility of steel make it a preferable material as a reinforcing member in concrete. According to Ojha et al. [1], the tensile strength of plain concrete is about one-tenth ($1/10^{\text{th}}$) of its compressive strength. Additionally, the modulus of elasticity of steel is about 200 KN/mm^2 while the modulus of elasticity for concrete is about 30 N/mm^2 . Therefore, a composite construction that can withstand compressive and tensile loads is produced by reinforcing the plain concrete. According to Nawy [2] the elastic modulus, ductility, and yield or rupture strength of the reinforcing steel must be much higher than those of the concrete in order to increase the capacity of the reinforced concrete section to a significant level. The strength of reinforcing steel has a very significant influence on the performance of beams, columns, slabs, and other structural members reinforced with these bars. At the design stage of construction projects, the structural engineer selects the most appropriate section of reinforcing steel required to withstand the loads considering the characteristic strength of the steel to be used. According to BS 4449: 2005 [3], the characteristic strength (f_y) of steel reinforcement is the value of the yield stress below which not more than 5% of the test material should fall. Hence, the physical characteristics of structural materials should satisfy the requirements of the underlying fundamental assumptions of the structural Codes of Practice upon which designs are based. In the case of beams, this is exhibited by the ability of the member to resist deflection under service and failure loads.

To produce good reinforcements for structural members, the BS 4449:2005+A2:2009 [3], ASTM A615 [4], and the GS 788-2:2018 [5] serve as useful guide for producers, fabricators, and buyers of ribbed reinforcing steel (bars, coils, and de-coiled products). These codes offer designations based on the steel grade, the product form, and the dimensions. They also define all typical technical specifications for reinforcing steels, such as chemical analysis, mechanical qualities, rib shape, and dimension tolerances. In terms of chemical composition, specifically the carbon equivalent value, the weldability standards for all classes of steel are given. The values of individual elements and the carbon equivalent shall not exceed the limits specified by BS4449:2005+A2:2009 [3] and GS 788-2:2018 [5]. Any bar that is outside the maximum stated limits in these codes during product analysis is regarded as not complying with the British and Ghana standards.

The Ghanaian construction industry relies extensively on steel as a reinforcing member for most of its civil and structural engineering works. The high demand for reinforcing steel for construction has prompted some local steel milling companies to produce reinforcement from scrap metals and obsolete vehicle parts to augment the tonnage that is imported. These bars usually have surface ribs to improve bond resistance, much like conventional high-yield deformed bars (Kankam [6]; Buabin et al.[7]; Assiamah et al.[8]; Assiamah et al.[9]). However, the quality standards of these reinforcements have been criticized by the general public, practitioners in the construction industry, and various professional bodies across the country. Even though the Ghana Standard Authority (GSA) has detailed specifications that manufacturers are expected to follow, the capacity of this institution to ensure

adherence to these standards has been indoubt (Kankam and Adom-Asamoah [10]).

This research assessed the strength and deformation behaviour of structural beams reinforced with locallymanufactured mild steel reinforcement bars in Ghana. Reinforcement bars of 12mm nominal diameter from three local milling companies randomly classified as STSL, B5PL, and FBML were used in structural beams for the experiment. Similar tests were also conducted on reinforcing bars imported from a foreign country classified herein as AM. The resultsobtained from beams reinforced with these imported bars were compared with results from beams reinforced with the three local milling companies.

2.0 LITERATURE FROM RELATED RESEARCH

Kankam and Adom-Asamoah [10] researched the strength and ductility characteristics of reinforcing steel bars milled from scrap metals. Twelve (12) reinforced concrete beams were cast with concrete of mix ratio 1:2:4 by weight and cured for 28 days after which they were subjected to testing. Even though the concrete beams were designed as under-reinforced, expecting the steel which was classified as mild to yield first before the concrete started to crush with an anticipated large and plastic regime in the load-deflection curve, failure of the beams was largely brittle with very little increased deflection before the collapse. The experimental failure loads were high and averaged approximately 160% over the predicted values which were based on yield strengths of steel of either 340N/mm², 370N/mm², or 490N/mm² with a partial factor of safety of 1.15. Under monotonic loading, the maximum deflections exceeded the predicted values on average by approximately 50%. However, in the case of the beams that were subjected to cyclic loading, the actual deflections at collapse were less and averaged approximately 76% of the predicted values. This is likely due to the brittle nature of the steel bars, which is adversely affected by fatigue even under this limited cyclic loading. This may result in structural members that are brittle and unsafe during earthquake occurrence and other dynamic loadings. Although the majority of the individual samples had strengths greater than the characteristic strength, giving manufacturers false confidence in their quality control level, the fact that the percentage elongation of all the test samples did not meet the code minimum requirement of 22% for mild steel places the behavior of the locally milled steel bars in a domain between mild and high-yieldsteel.

Quarm Junior et al. [11] also examined the structural behavior of concrete beams reinforced with local steel bars available in Ghana. The primary reinforcing steel bars used in the concrete beams were 12 mm mild and 12 mm high tensile steel bars manufactured by Ferro Fabric Limited (FFL), United Steel Company (USC), Sentuo Steel Limited (STS), and Fabrimetal (FAB). Both theoretical and experimental methods were used to analyze the data that were gathered. While they were seen to be marginally lower in the beams reinforced with mild steel bars, the experimental cracking and failure loads in the beams reinforced with high-yield steel bars were, on average, slightly greater than the theoretical loads. In terms of cracking, the authors observed that the FFL ribbed mild steel reinforced

beam had the most cracks at failure when compared to the bars from the other companies, indicating a very high bonding between the steel and the concrete. Of the steels used for reinforcement, beams reinforced with FAB high-yield steel exhibited the highest failure load.

Adom-Asamoah and Kankam [12] investigated the flexural behaviour of one-way concrete slabs reinforced with steel bars milled from scrap metals. Twelve (12) one-way, simply-supported concrete slabs reinforced with steel bars milled from scrap metal were tested in the laboratory. The slabs were subjected to concentrated line loads at the third points. It was predicted that either flexural yielding of the steel tension bar or flexural crushing of the concrete would be the failure in two separate ways. The failure modes that were noted, however, were either shear bond failures, diagonal shear, tension failure, concrete crushing, or a combination of these. A short-term factor of safety of roughly 1.3 against cracking and 0.94 against collapse was obtained from the experimental results on average for one-way slabs with span-to-effective depth ratios varying between 14 and 24.37, and shear span-to-effective depth ratios varying between 4.6 and 8.12. Based on the findings of the experiments, it was suggested that an average steel strength of roughly 370 N/mm^2 for steel bars milled in Ghana be utilized in reinforced concrete design rather than the typical value of 250 N/mm^2 required by BS8110 for mild steel.

Furthermore, Kankam and Adom-Asamoah [13] assessed the shear strength of concrete beams reinforced with steel bars milled from scrap metals. Concrete beams reinforced with locally manufactured mild steel bars to withstand flexural tensile and shear loads were evaluated using a two-point loading technique to create a central constant moment section and outside shear spans. Before the collapse, the tested beams showed negligible deflection and extremely little ductility. The experimental failure loads for the beams averaged 123% of the theoretical failure load, which was typically determined by the shear or yielding of the tension steel. Shear failure was mostly caused by diagonal tension fractures, followed by either crushing or splitting of the concrete over the longitudinal tensile bars near the supports. The failure of the beams was brittle, with an average strain energy absorption of 357.9 Nm after they cracked. At failure, the maximum crack width in the beams ranged from 1.12mm to 5.0 mm, with the largest sizes forming in the diagonal shear cracks.

3.0 MATERIALS AND METHODS

3.1 Materials

The materials used for the test were ordinary Portland cement of 32.5R grade, fine aggregate (pit sand), and coarse aggregate (10mm maximum size). The fine and coarse aggregates were obtained locally in the Ashanti Region. These constituent materials were mixed in a ratio of 1:1.5:3, giving a strength class of C25. concrete produced from these constituent materials Samples of 12mm nominal size reinforcing steel from all three milling companies namely; STSL, B5PL, and FBML as well as the imported high-tensile bars (AM), were also prepared for the test.

3.2 Control Specimens

Control specimens were prepared and tested to determine the workability of the fresh concrete as well as the strength of the hardened concrete. These tests included the slump test, compressive strength test, and split tensile strength test. The results of these tests are shown in Table 1. Figure 1 illustrates tests on fresh and hardened concrete control concrete specimens.

Table 1: Results of Tests on the Concrete.

Test	Slump	28 th day Compressive Strength	28 th day Split Tensile Strength
Result Obtained	12mm	22.13 N/mm ²	2.16 N/mm ²



(a) Slump Test on the Fresh Concrete.



(b) Compressive Strength of Cubes.



(c) Splitt Tensile Strength Test on Cylinder

Fig. 1: Testing of Concrete Control Specimens.

3.30 Preparation and Testing of Reinforced Concrete Beams

A total of twenty-four beams of dimensions 2000mm x 120 mm x 200 mm with reinforcing steel bars from the three local milling companies as well as imported foreign brands were prepared for the test. Six (6) beams each were prepared (as shown in Table 2) with bars from the three local milling companies as well as the imported bars. For each beam, two 12 mm diameter bars were used in the tension zone (bottom) with a clear concrete cover of 18 mm while two 8 mm diameter bars were used in the compression zone (top), also with a clear concrete cover of 18 mm. The stirrups had a diameter of 8 mm and were spaced at 160mm centers. Tables 3 and 4 present the mechanical and physical properties of the reinforcing bars from the three local milling companies (namely; STSL, B5PL, and FMBL) as well as the imported reinforcement described herein as AM.

Concrete was poured into the wooden formworks in layers and adequately compacted using a poker vibrator to ensure that there was no entrapped air within the concrete. The concrete beam specimens were then left to dry for 24 hours after which they were removed from the formworks and cured under hessian sacks for 28 days. They were then cleaned of any dirt, painted with white emulsion paint, and left to dry. Figure 2 shows some samples of the reinforced concrete beam specimens being prepared for the experiment. The testing apparatus, which included a rigid steel frame, a 200 KN capacity hydraulic jack actuator and load cell, permanent markers, a transparent measuring rule, a magnifying glass, and thread was used. A two-point symmetrical loading (with each load being 200mm from the midpoint) was chosen with the beam mounted on the rigid steel frame. The loading of the beam was done using the hydraulic jack actuator at 2 KN intervals. Inspections were conducted intermittently to monitor cracks on the beam with a magnifying glass as the beams were being subjected to incremental loads. A digital dial gauge mounted beneath the beam at the center was used to measure the deflection of the beam as they were loaded. Records were kept of the initial crack load, deflection, total number of cracks, crack spacing, maximum crack width, crack length, and final failure load. Figure 3 shows the testing of some selected beam specimens.

Table 2: Quantities of Test Beams

	STSL		B5PL		FBML		AM	
	Bar Size	Number of beams	Bar Size	Quantity of Specimen	Bar Size	Quantity of Specimen	Bar Size	Quantity of Specimen
	12mm	6	12mm	6	12mm	6	12mm	6
Total		6		6		6		6



Fig.2: Preparation of Reinforced Concrete Beam Specimens.

Table 3: Mechanical Properties of Reinforcing Steel Bars.

BarID	BarType	Nominal Bar size (mm)	Yield Strength (f_y) N/mm ²	Yield Strain (E_y)	Max Strength(f_{max}) N/mm ²	Ultimate Strength (f_{ult}) N/mm ²	Total Elongation (%)
STSL R12	Mild Steel	12	378.59	0.0024	501.57	468.87	26.02
B5PL R12	Mild Steel	12	458.23	0.0026	555.19	484.24	18.45
FBML R12	Mild Steel	12	414.66	0.0033	537.39	457.41	18.76
AM T12	High-Tensile	12	496.99	0.0035	762.73	679.25	10.04
FBML R8 *	Mild Steel	8	362.34	0.0021	482.49	423.61	14.78

* Stirrups and Compression Reinforcement.

Table 4: Physical Properties of Reinforcing Steel Bars.

S/N	Source of Bar	Bar ID	Bar Type	Nominal Bar size (mm)	Average Bar Diameter (mm)	Deviation from Nominal Diameter (%)	Rib Height (mm)	Rib Spacing (mm)
1.	STSL	STSL R12	Mild Steel	12	10.76	10.33	0.419	9.531
2.	B5PL	B5PL R12	Mild Steel	12	11.03	8.08	1.138	8.857
3.	FBML	FBML R12	Mild Steel	12	10.80	10	0.743	8.967
4.	AM (imported bars)	AM T12	High-Tensile	12	11.97	0.25	1.039	7.320
5.	FMBL	FBML R8	Mild Steel	8	6.17	22.88	0.342	3.16
Mean					10.146		0.736	7.567
Standard Deviation					2.035		0.319	2.322

* Stirrups and Compression Reinforcement

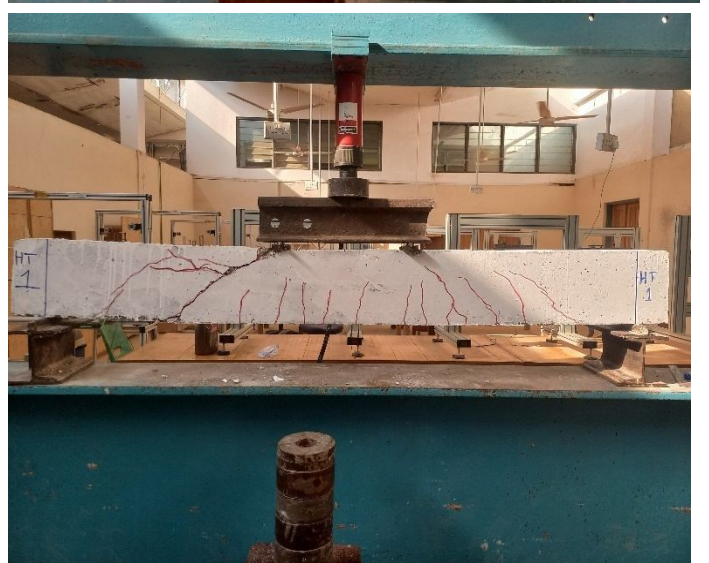
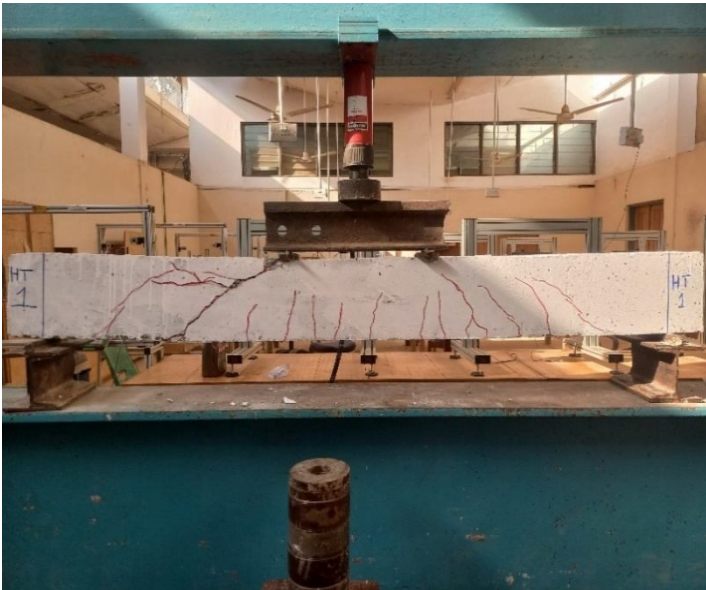

Fig 3: Beam Specimens during and after testing.

3.4 Theoretical Analysis

3.4.1 Tensile Strength of Concrete.

The tensile strength of plain concrete was obtained using the results from the split cylinder test. The split cylinder strength is given by equation 1:

$$f_t = \frac{2P_{max}}{\pi DL} \quad \text{Equation 1.}$$

where:

- f_t = Split cylinder strength (N/mm²).
- P_{max} = Maximum crushing load (N).
- D = Diameter of cylinder (150 mm).
- L = Length of cylinder (300 mm).

The average split cylinder strength was 2.16 N/mm² as shown in Table 1.

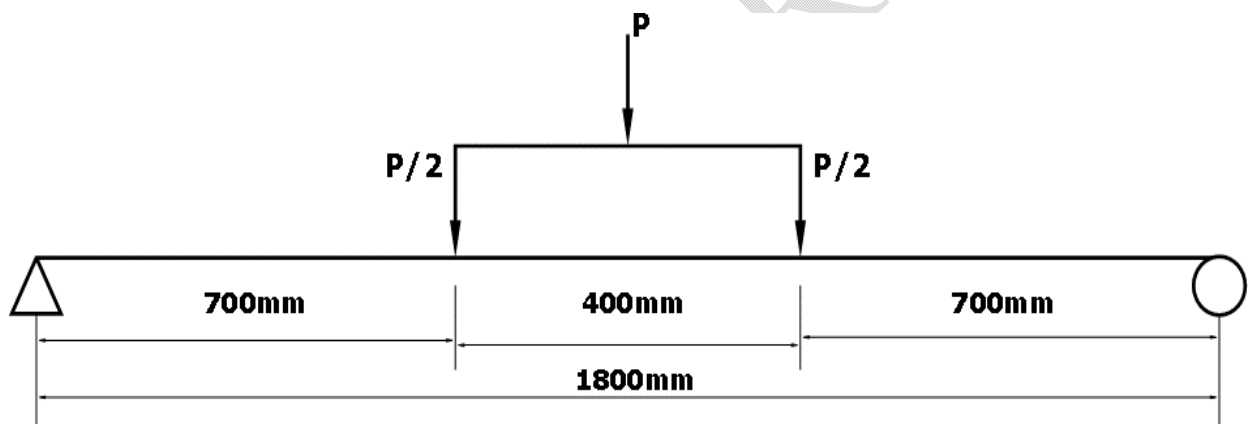

Fig.4: Diagrammatic representation of loaded beam specimen

3.4.2 Cracking Load

3.4.2.1 Cracking moment of reinforced concrete beam

The cracking moment for a reinforced concrete beam loaded at two points as shown in Figure 4 is given by equation 2:

$$M_{cr} = P_{cr} \times \frac{L}{2} \quad \text{Equation 2.}$$

Where:

- M_{cr} = Cracking moment of beam.
- P_{cr} = Theoretical cracking load.
- L = Distance from the support to the load point (700 mm).

3.4.2.2 Theoretical Cracking Load for Beams

The theoretical cracking load of the simply supported beam is therefore obtained from equation 3 with same terms as in equation 3:

$$P_{cr} = 2M_{cr}/L \quad \text{Equation 3.}$$

Under vertically low applied loads, the reinforced concrete beam is assumed to exhibit elastic behavior and therefore obey the Euler-Bernoulli's relationship as expressed in equation 4 as follows:

$$M_{cr}/I = f_t/y \quad \text{Equation 4.}$$

where:

- M_{cr} = Cracking moment and is given by equation 2.
- f_t = Split cylinder tensile strength (N/mm^2).
- y = Distance to extreme tension face ($= D/2$).
- I = $bD^3/12$ = second moment of area of concrete beam (mm^4).
- D = Overall depth of the beam (200 mm).
- b = Width of the Beam (120 mm).

Table 3 presents the theoretical cracking loads for all the beams for the experiment.

3.4.3 Analysis of Theoretical Failure Load

3.4.3.1 Theoretical Failure Load on Assumption that the Steel Bars Yield First

The moment of resistance of the reinforced concrete beam on the assumption that the tension reinforcement fails first is given by equation 5:

$$M_{ult} = M_{rs} = 0.87f_y A_s \cdot 0.775d \quad \text{Equation 5.}$$

where:

- f_y = Yield strength of tensile steel reinforcement
- d = Effective depth of the beam.
- A_s = Area of steel reinforcement in the tension zone.
- M_{rs} = Moment of resistance of the reinforcement intension.

The ultimate load of a beam simply supported and loaded as shown in figure 4 is given by equation 6.

$$P_{ult} = 2M_{rs}/L \quad \text{Equation 6.}$$

where:

- P_{ult} = Ultimate load.
- M_{rs} = Moment of resistance of the reinforcement intension
- L = Distance of support from the nearest point load as in Figure 4 = 700 mm.

3.4.3.2 Theoretical Failure Load on Assumption that Concrete Crushes First

The moment of resistance of the reinforced concrete beam, supported and loaded (as shown in Figure 4), and on the assumption that the concrete crushes first in compression is given by:

$$M_{ult} = M_{rc} = 0.156f_{cu}bd^2 + 0.5f_yA_s(d-d') \quad \text{Equation 7.}$$

where:

f_{cu} = compressive strength of concrete.

- d = Effectivedepth.
- d' = Depth of compression steel bars.
- B = Width of thebeam.
- f_y = Compressive strength of mild steel bars.
- A_s = Area of steel reinforcement incompression.
- M_{rc} = Moment of resistance based on failure in compressionfirst.

The ultimate failure load based on concrete crushing first is expressed as:

$$P_{ult} = 2M_{ult}/L \quad \text{Equation 8.}$$

where:

- P_{ult} = Ultimate failure load.
- M_{ult} = Ultimate Moment.
- L = Distance of support from the nearest point load (700 mm).

3.4.3.3 Theoretical Failure Load on the Assumption that Shear Failure Occurs First

Shear failure load (V_r) including resistance of steel bars as stirrups in the beam is as follows:

$$V_r = 0.87 \frac{A_{sv}f_{yv}.d + v_c.b.d}{S_v} \quad \text{Equation 9.}$$

where:

- V_r = Shear failureload.
- f_{yv} = Yield strength of the links.
- v_c = Design concrete shearstress.
- A_{sv} = Area of 2 legs of the links at the section of the Neutral axis.
- b = Width of thebeam.
- D = Effective depth of thebeam.

4.0 THEORETICAL AND EXPERIMENTAL RESULTS

4.1 Load-Deflection Curves

The load-deflection curves for all twenty-four beams from the various milling companies are presented in Figures 5 and 6. Out of the twenty-four beams, sixteen beams (four from each company) were subjected to monotonic loading while the remaining eight were tested under cyclic loading.

4.1.1 Monotonic Loading

Each of the sixteen beams was subjected to a monotonic loading with load increments of 2 KN and deflection measurements were taken at each load increment. The cracking load was recorded as the beam was loaded incrementally until it failed, at which point the failure load was recorded. The load-deflection curves in Figure 5 show initial straight and steep lines indicating the elastic behaviour of the beams before the development of flexural cracks. Once flexural cracks developed, the slope of the curves changed and remained fairly linear until the beams failed, mostly due to the steel yielding first, followed by crushing of the concrete after extensive deflection with cracks extending deeply into the compression zone of the concrete.

4.2 Cracking Load

The theoretical and experimental cracking loads for the beams under monotonic and cyclic loading are presented in Tables 5 and 6 respectively. The ratio of experimental cracking loads (P'_{cr}) to theoretical cracking loads (P_{cr}) averaged as 1.11 for STSL beams, and the same value 2.12 for B5PL beams, FBML beams, and AM beams under monotonic loading. For cyclic loading, the corresponding values were 1.01 for STSL, 1.22 for B5PL, 0.91 for FBML, and 1.52 for AM beams. It was observed that except for the STSL-reinforced beams, the beams reinforced with the other locally milled bars and the standard imported bar exhibited similar cracking loads with an average of 10.5KN. It could therefore be interpreted that the beams reinforced with AM, B5PL, and FBML bars could sustain similar higher loads before cracks could start to develop than STSL bars.

4.3 Failure Loads

Table 5 presents the theoretical and experimental failure loads of the beams subjected to monotonic loading. The theoretical failure loads for beams reinforced with STS bars under monotonic and cyclic loading based on steel yielding, concrete crushing, and shear failure were 29.03 KN, 45.03 KN, and 36.46 KN respectively. The beams reinforced with B5PL mild steel bars recorded 35.14 KN, 46.83 KN, and 36.46 KN for theoretical failure load based on steel yielding, concrete crushing, and shear failure respectively under monotonic and cyclic loading. Additionally, the beams reinforced with FBML mild steel bars also recorded a theoretical failure load of 31.80 KN, 45.83 KN, and 36.46 KN based on steel yielding, concrete crushing, and shear failure respectively under monotonic and cyclic loading. Lastly, the beams reinforced with AM had values for theoretical failure load based on either

steel yielding, concrete crushing, or shear failure to be 38.11 KN, 47.66 KN, and 36.46 KN respectively. With regard to the beams reinforced with locally manufactured bars (under monotonic loading), B5PL recorded the highest average experimental failure load of 56 KN. FBML recorded an average experimental failure load of 47 KN, while STSL recorded the lowest average of 38.5 KN. On the other hand, the beams reinforced with the standard high-yield bars (AM) recorded an average experimental failure load of 64.6 KN under monotonic loading. Regarding the beams under cyclic loading (Table 7), the beams reinforced with AM recorded the highest average experimental failure load of 73 KN, followed by B5PL which recorded an average of 55 KN. FBML recorded an average experimental failure load of 54 KN while STSL maintained the lowest average experimental failure load of 41 KN. The increased experimental failure load for beams reinforced with AM could be attributed to the high tensile strength properties of such reinforcing bars. Under monotonic loading, the ratio of experimental failure loads (P'_{ult}) to the theoretical failure loads (P_{ult}) averaged 1.33 for STSL beams, 1.59 for B5PL beams, 1.47 for FBML beams, and 1.77 for AM beams. It could be seen that the margin of safety ranges from 33 to 59 percent for the local bars, and 77 percent for the imported. On the other hand, under cyclic loading, the experimental failure loads averaged the theoretical as 1.42 for STSL, 1.57 for B5PL, 1.7 for FBML, and 2.0 for AM-reinforced beams.

4.4 Cracking Mode

Tables 6 and 8 present the maximum deflection at failure, the number of cracks, the maximum crack width, and the crack patterns for the various beams under monotonic and cyclic loading respectively. With all the beams subjected to monotonic loading, AM recorded the least average deflection of 17.59 mm even though they were subjected to high experimental average cracking loading of 10.5 KN with an average maximum crack width of 4 mm at failure. The average crack spacing was 82.25 mm with an average number of 13.75 cracks. Among the beams reinforced with the three locally manufactured reinforcing steel bars, B5PL recorded the least deflection of 18.93 mm (on average) having been subjected to an average experimental cracking load of 10.5 KN. Additionally, these beams had the least maximum crack width of 1.0 mm and an average crack spacing of 67.5 mm. An average of 11.25 cracks were recorded by these beams. Beams reinforced with FBML recorded an average maximum deflection of 21.66 mm, having been subjected to a cracking load of 10.5 KN. These bars had a maximum crack width of 3 mm and an average crack spacing of 69.75 mm. An average of 19.5 cracks were recorded by these beams. The beams reinforced with STSL bars recorded the highest deflection of 22.29 mm under the least average cracking load of 4.5 KN. These beams had an average maximum crack width of 2 mm and an average crack spacing of 136.5 mm. On average, 15.5 cracks were also recorded on these beams.

Regarding the beams subjected to cyclic loading, AM again recorded the least maximum deflection of 16.73 mm with an average maximum crack width of 7.5 mm and an average cracking load of 7.5 KN. An average crack spacing of 70mm was recorded with 21 cracks at failure (on average). Apart from the beams reinforced with imported bars (AM), beams reinforced with B5PL recorded the least maximum deflection of 18.57 mm under an average cracking load of 7 KN. Unlike those beams reinforced with

B5PL under monotonic loading, these beams recorded an average crack width of 2 mm with an average crack spacing of 57 mm. On average, 18.5 cracks developed in these beams. Following B5PL-reinforced beams were beams reinforced with STSL. These beams on average, had a maximum deflection of 21.67 mm and a maximum crack width of 3mm. The beams reinforced with FBML recorded the highest maximum deflection of 24.02 mm on average and a maximum crack width of 3 mm. The average crack spacing for these beams was 70 mm with an average number of 20 cracks.

It could be observed that the beams reinforced with AM for (both monotonic and cyclic loading) had better resistance to deflection even though they were subjected to relatively much greater loads. This could be attributed to the high rigidity and bonding properties under high tensile capacity of the bars. Among the mild steel bars from the three local milling companies (under monotonic and cyclic loading), B5PL had the best resistance to deflection even under a greater load as compared to FBML and STSL. Additionally, beams reinforced with B5PL had the smallest crack width and exhibited good cracking, signaling a good bond between the bars and the surrounding concrete. The authors predicted this observation, as earlier research by Biney et al. [14] showed much better surface geometry, chemical composition, and mechanical properties among the same locally manufactured reinforcements studied. FBML showed greater performance in terms of maximum deflection under monotonic loading while STSL-reinforced beams performed better under cyclic loading.

4.5 Failure Mode

The mode of failure for beams subjected to monotonic and cyclic loading is influenced by several factors such as the bond between the reinforcing bar and the concrete, the strength of the concrete, type, and size of the reinforcing bar in the compression and tension zones, size and spacing between stirrups, etc. Tables 6 and 8, and Figure 3 show the types of cracks that were developed on the beams at failure (under monotonic and cyclic loading). With all the beams, the first crack was found to appear within the middle third span where the maximum strain occurred.

Table 4 shows the physical properties of the reinforcements used for this experiment as obtained from earlier research conducted by the same authors. The actual bar size for beams reinforced with STSL was 10.76mm. The rib height of this reinforcing bar was 0.419 mm with a rib spacing of 9.531mm. The yield strength was 378.59 N/mm² with an ultimate strength of 468.87 N/mm². STSL/1, STSL/2, STSL/3, and STSL/4 had an average of seven pure flexural cracks within the constant moment area, three flexural shear cracks outside the constant moment area, and five diagonal shear cracks. The beams reinforced with B5PL bars also had an actual bar size of 11.03mm. The rib height and rib spacing for these bars were 1.138mm and 8.857mm respectively. These bars had a yield strength of 458.23 N/mm² with an ultimate strength of 484.24 N/mm². On average, B5PL/1, B5PL/2, B5PL/3, and B5PL/4 had six pure flexural cracks within the constant moment area, one flexural shear crack outside the constant moment area, and five diagonal shear cracks. Regarding the FBML-reinforced beams, the reinforcing bars had an actual diameter of 10.80mm. The rib height and rib spacing were 0.743mm and 8.967mm respectively. An average of seven pure flexural cracks within the constant moment area, five flexural shear cracks outside the constant moment area, and eight diagonal cracks were recorded for the

beams designated as FBML/1, FBML/2, FBML/3, and FBML/4. Furthermore, the beams reinforced with AM had an average of six pure flexural cracks within the constant moment area, two flexural shear cracks outside the constant moment area, and six diagonal shear cracks. The actual diameter for these reinforcing bars was 11.97mm. Additionally, the rib height and rib spacing for these reinforcements were 1.039mm and 7.320 mm respectively. It is important to note that one of these beams experienced a sudden shear failure in the course of the testing.

In the case of beams subjected to cyclic loading, the STSL-reinforced beams had on average, nine pure flexural cracks within the constant moment area, five flexural shear cracks, and five diagonal shear cracks in the shear span zone. The beams reinforced with B5PL reinforcing bars had an average of seven pure flexural cracks, four flexural shear cracks, and nine diagonal shear cracks. FBML-reinforced beams recorded an average of eight pure flexural shear cracks, three flexural shear cracks, and nine diagonal shear cracks. Lastly, the beams reinforced with AM bars recorded an average of seven pure flexural shear cracks, eight flexural shear cracks, and six diagonal shear cracks with concrete crushing at the compression zone.

Table 5: Cracking and Failure Loads of Beams under Monotonic Loading

Beam ID	Theoretical Cracking Load, P_{CR} (KN)	Experimental Cracking Load, P'_{CR} (KN)	Theoretical Failure Load, P_{ult} Based on			Experimental Failure Load P'_{ULT} (KN)	$\frac{P'_{CR}}{P_{CR}}$	$\frac{P'_{ULT}}{P_{ULT}}$
			Steel Yielding (KN)	Concrete Crushing (KN)	Shear Failure (KN)			
STSL/1	4.94	5	29.03 *	45.03	36.46	38	1.01	1.31
STSL/2	4.94	4.5	29.03 *	45.03	36.46	42	0.91	1.45
STSL/3	4.94	4.5	29.03 *	45.03	36.46	36	0.91	1.24
STSL/4	4.94	8	29.03 *	45.03	36.46	38	1.62	1.31
		Average 5.5				38.5	1.11	1.33
B5PL/1	4.94	10	35.14 *	46.83	36.46	58	2.02	1.65
B5PL/2	4.94	10	35.14 *	46.83	36.46	60	2.02	1.71
B5PL/3	4.94	12	35.14 *	46.83	36.46	52	2.43	1.45
B5PL/4	4.94	10	35.14 *	46.83	36.46	54	2.02	1.54
		Average 10.5				56	2.12	1.59
FBML/1	4.94	12	31.80 *	45.83	36.46	46	2.43	1.45
FBML/2	4.94	10	31.80 *	45.83	36.46	40	2.02	1.23
FBML/3	4.94	12	31.80 *	45.83	36.46	52	2.43	1.64
FBML/4	4.94	8	31.80 *	45.83	36.46	50	1.62	1.57
		Average 10.5				47	2.12	1.47
AM/1	4.94	12	38.11	47.66	36.46 *	66	2.43	1.81
AM/2	4.94	10	38.11	47.66	36.46 *	66	2.02	1.81
AM/3	4.94	10	38.11	47.66	36.46 *	66	2.02	1.81
AM/4	4.94	10	38.11	47.66	36.46 *	60	2.02	1.65
		Average 10.5				64.6	2.12	1.77

Note: * Governing failure load

Table 6:Cracking Mode of Beams Under Monotonic Loading

Beam ID	Maximum Deflection at Failure (mm)	Maximum Crack Width at Failure (mm)	Average Crack Spacing (mm)	Number of Cracks at Failure	Types of Cracks at Failure
STSL/1	23.81	2	95	11	7 Pure flexural cracks + 2 flexural-shear cracks + 2 diagonal shear cracks. Crushing of concrete at the compression zone within the loaded region.
STSL/2	22.70	2	110	12	5 Pure flexural cracks + 3 flexural-shear + 4 diagonal shear cracks
STSL/3	20.60	2	163	18	7 Pure flexural cracks + 3 flexural-shear + 5 diagonal shear cracks
STSL/4	22.03	2	178	21	9 Pure flexural cracks + 4 flexural-shear + 8 diagonal shear cracks
Average	22.29	2	136.5	15.5	
B5PL/1	23.17	1	75	13	7 Pure flexural cracks + 7 diagonal shear cracks
B5PL/2	17.48	1	65	5	5 Pure flexural cracks
B5PL/3	18.54	1	70	14	6 Pure flexural cracks + 1 flexural-shear + 5 diagonal shear cracks
B5PL/4	16.51	1	60	13	5 Pure flexural cracks + 8 diagonal shear cracks
Average	18.93	1	67.5	11.25	
FBML/1	21.65	3	65	22	8 Pure flexural cracks + 4 flexural-shear + 10 diagonal shear cracks Crushing of concrete at the compression zone within the loaded region.
FBML/2	20.28	3	84	16	6 Pure flexural cracks + 3 flexural-shear + 7 diagonal shear cracks
FBML/3	23.60	3	65	22	6 Pure flexural cracks + 5 flexural-shear + 11 diagonal shear cracks Crushing of concrete at the compression zone
FBML/4	21.10	3	65	18	8 Pure flexural cracks + 7 flexural-shear + 3 diagonal shear cracks Crushing of concrete at the compression zone
Average	21.66	3	69.75	19.5	
AM/1	15.99	5	95	6	1 Pure flexural crack + 1 flexural-shear + 4 diagonal shear cracks Sudden shear failure.
AM/2	12.84	5	85	13	6 Pure flexural cracks + 1 flexural-shear + 6 diagonal shear cracks
AM/3	18.47	3	74	17	8 Pure flexural cracks + 2 flexural-shear + 7 diagonal shear cracks
AM/4	23.05	3	75	19	9 Pure flexural cracks + 3 flexural-shear + 7 diagonal shear cracks
Average	17.59	4	82.25	13.75	

Table 7: Cracking and Failure Loads of Beams Under Cyclic Loading.

Beam ID	Theoretical Cracking Load, P_{CR} (KN)	Experimental Cracking Load, P'_{CR} (KN)	Theoretical Failure Load, P_{ult} Based on			Experimental Failure Load P'_{ULT} (KN)	$\frac{P'_{CR}}{P_{CR}}$	$\frac{P'_{ULT}}{P_{ULT}}$
			Steel Yielding (KN)	Concrete Crushing (KN)	Shear Failure (KN)			
STSL/5	4.94	5	29.03 *	45.03	36.46	44	1.01	1.52
STSL/6	4.94	5	29.03 *	45.03	36.46	38	1.01	1.31
		Average 5				41	1.01	1.42
B5PL/5	4.94	8	35.14 *	46.83	36.46	56	1.62	1.59
B5PL/6	4.94	4	35.14 *	46.83	36.46	54	0.81	1.54
		Average 6				55	1.22	1.57
FBML/5	4.94	5	31.80 *	45.83	36.46	54	1.01	1.70
FBML/6	4.94	4	31.80 *	45.83	36.46	54	0.81	1.70
		Average 4.5				54	0.91	1.70
AM/5	4.94	5	38.11	47.66	36.46 *	74	1.01	2.03
AM/6	4.94	10	38.11	47.66	36.46 *	72	2.02	1.97
		Average 7.5				73	1.52	2.0

Note: * Governing failure load

Table 8: Cracking Mode of Beams Under Cyclic Loading

Beam ID	Maximum Deflection at Failure (mm)	Maximum Crack Width at Failure (mm)	Average Crack Spacing (mm)	Number of Cracks at Failure	Types of Cracks at Failure
STSL/6	20.16	3	65	20	9 Pure flexural cracks + 7 flexural-shear cracks + 4 diagonal shear cracks.
STSL/6	23.17	3	70	18	10 Pure flexural cracks + 2 flexural-shear + 6 diagonal shear cracks
Average	21.67	3	67.5	19	
B5PL/5	19.66	2	54	19	8 Pure flexural cracks + 4 flexural-shear + 7 diagonal shear cracks.
B5PL/6	17.48	2	60	18	7 Pure flexural cracks + 11 diagonal cracks.
Average	18.57	2	57	18.5	
FBML/5	21.76	3	68	23	9 Pure flexural cracks + 3 flexural-shear + 11 diagonal shear cracks
FBML/6	26.28	3	72	17	6 Pure flexural cracks + 4 flexural-shear + 7 diagonal shear cracks
Average	24.02	3	70	20	
AM/5	17.52	5	64	24	8 Pure flexural crack + 9 flexural-shear + 7 diagonal shear cracks Crushing of concrete at the compression zone.
AM/6	15.94	10	76	18	7 Pure flexural cracks + 6 flexural-shear + 5 diagonal shear cracks
Average	16.73	7.5	70	21	

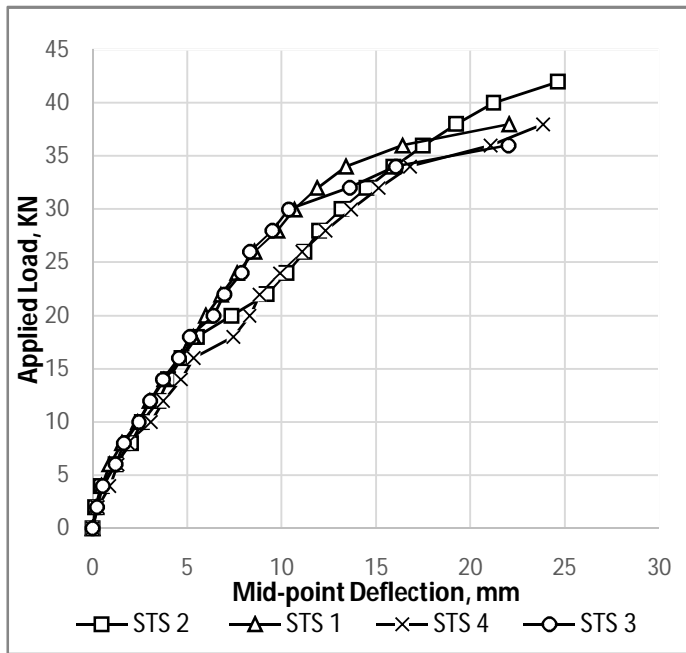

(a) Deflection of Beams Reinforced with STS Bars.

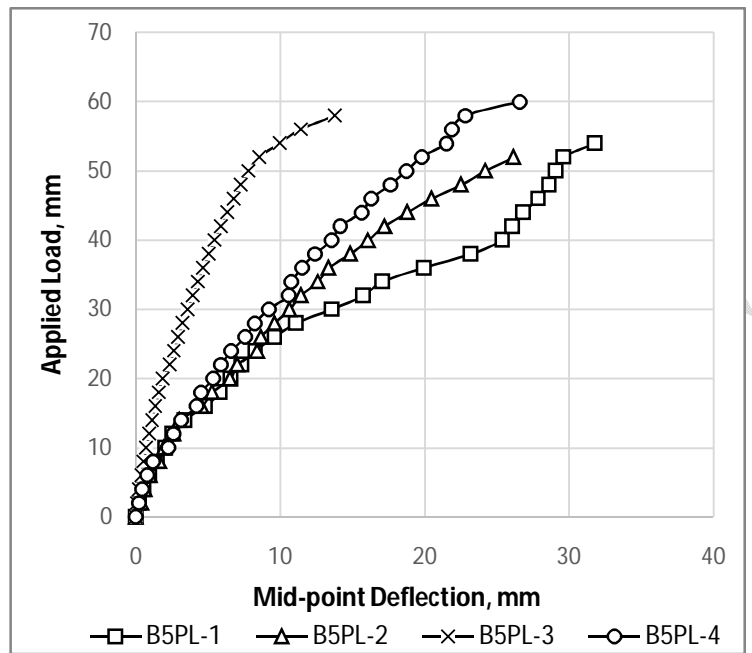

(b) Deflection of Beams Reinforced with B5PL Bars.

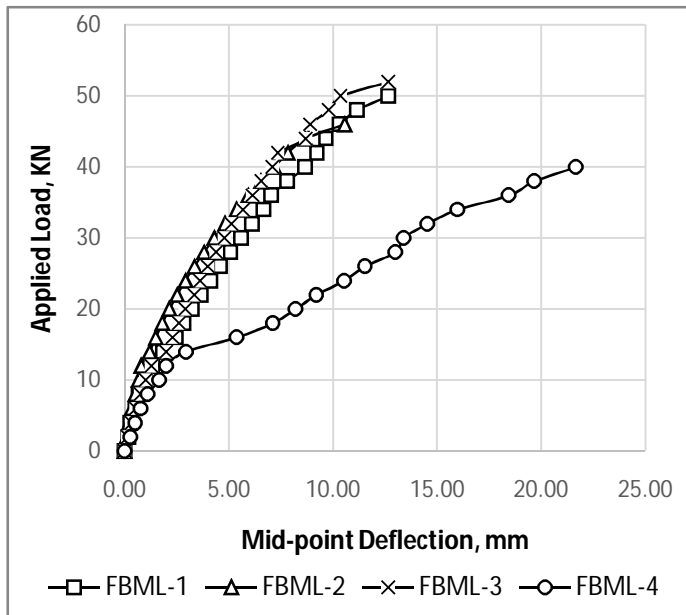

(c) Deflection of Beams Reinforced with FBML bars.

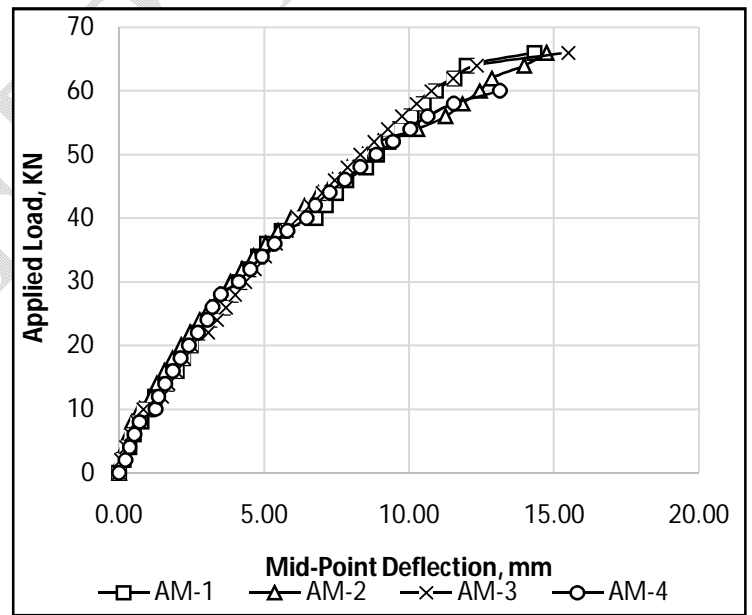

(d) Deflection of Beams Reinforced with AM bars.

Figure 5: Load-deflection Curves for Beams Under Monotonic Loading.

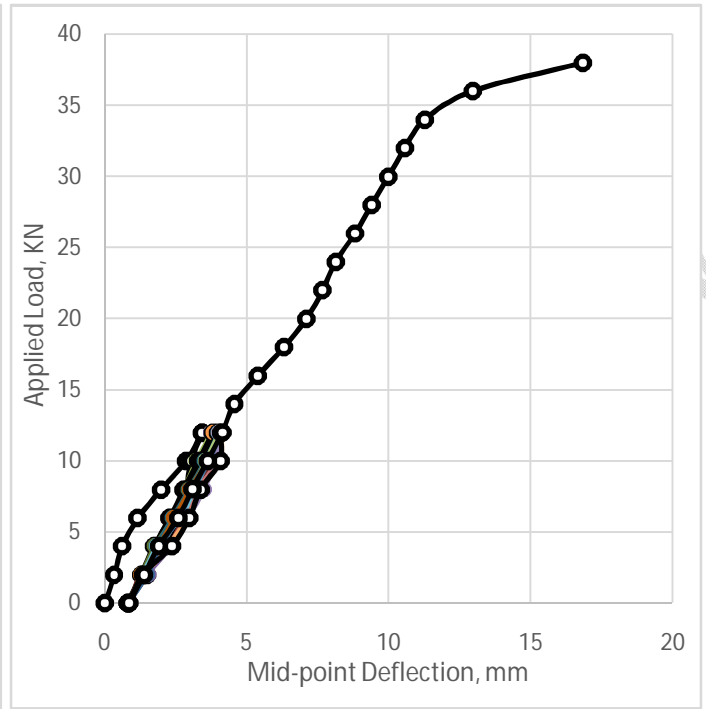
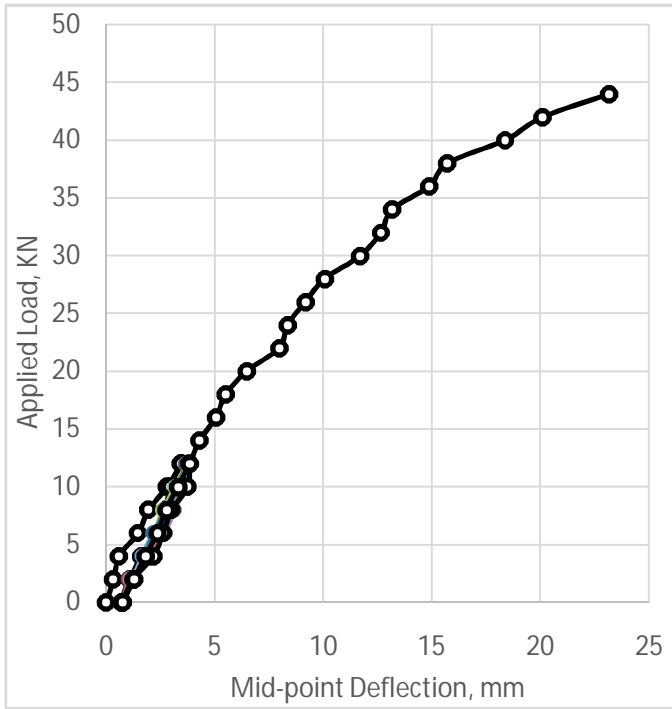

(a) Deflection of beams reinforced with STSL bars under cyclic loading.

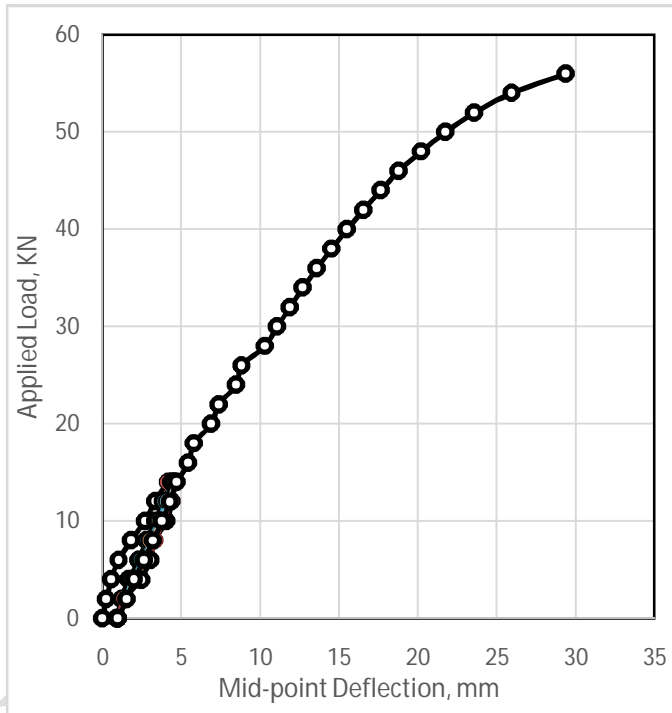

(b) Deflection of beams reinforced with B5PL bars under cyclic loading.

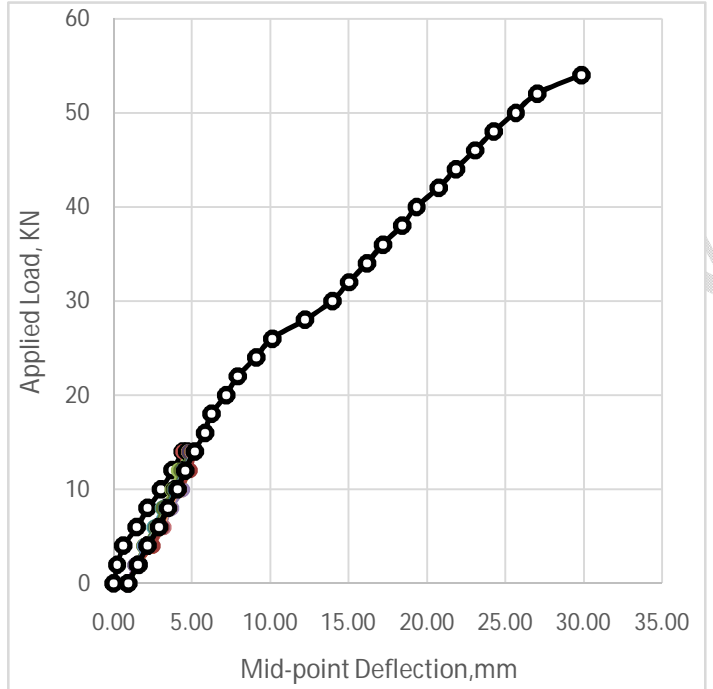
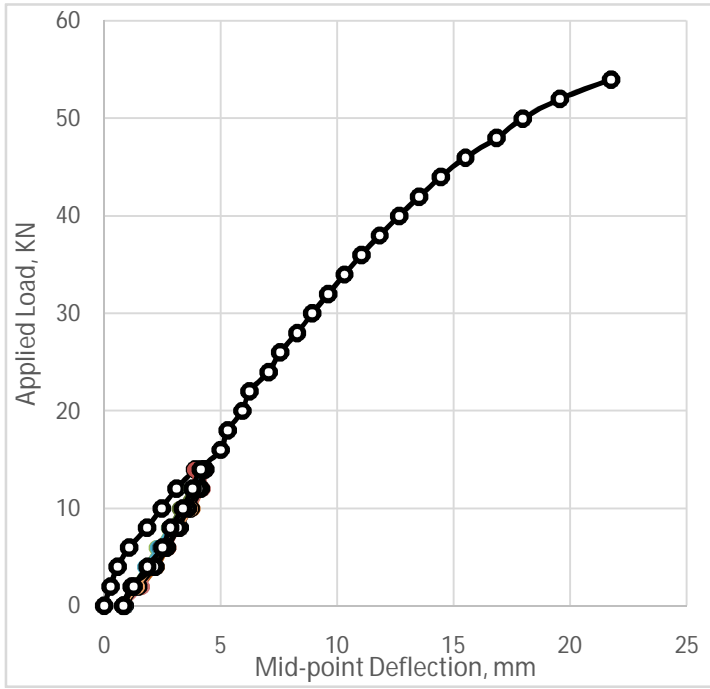

(c) Deflection of Beams Reinforced with FBML Bars under Cyclic Loading.

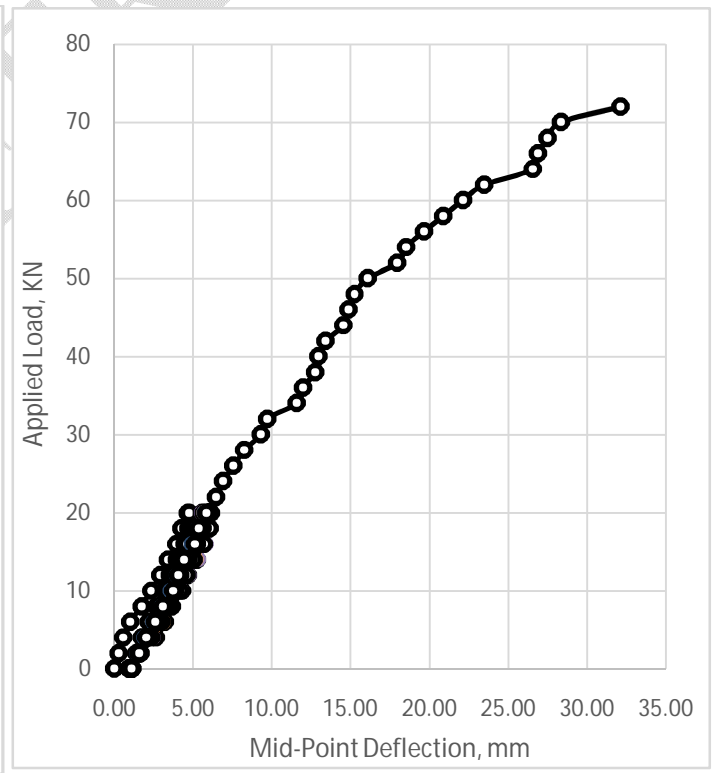
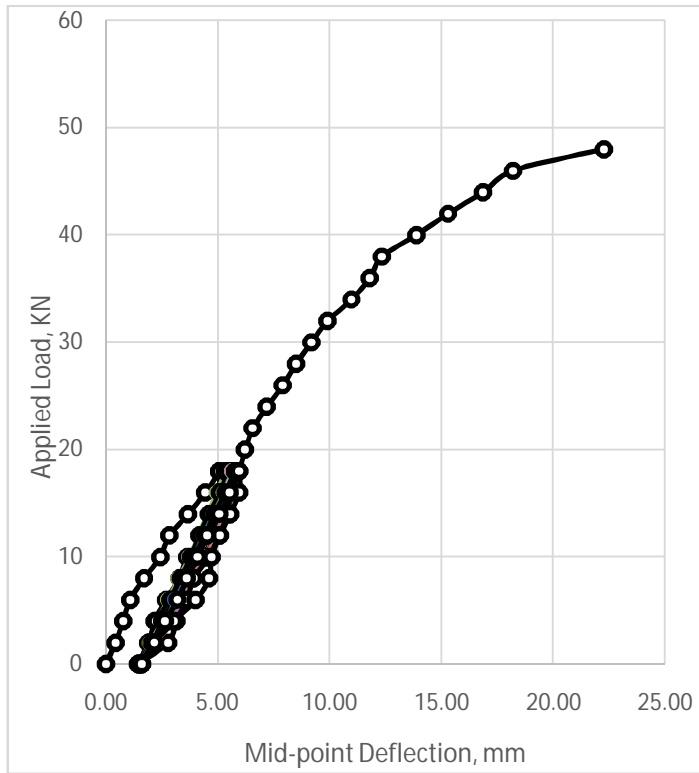

(d) Deflection of Beams Reinforced with AM bars Under Cyclic Loading.

Figure 6: Load–Deflection Curves for Beams Under Cyclic Loading.

5.0 CONCLUSION

The capacity of structural beams to perform satisfactorily under ultimate and serviceability conditions is enhanced by the physical and mechanical characteristics of their reinforcing bars. Additionally, the size and surface geometry of these reinforcing members affect the bond between the reinforcement and its surrounding concrete. This research assessed the strength and deformation behavior of structural beams reinforced with locally manufactured mild reinforcing steel bars (classified herein as STSL, B5PL, FBML) in Ghana. Similar tests were also conducted on imported standard high-yield reinforcing bars classified as AM. The study found that:

1. The beams reinforced with imported AM and two local bars (B5PL and FBML) under monotonic loading resisted a similar average experimental cracking load of 10.5 KN as compared with beams reinforced with local STSL reinforcing bars. The STSL-reinforced beams recorded the least average experimental cracking load of 4.5 KN. The high experimental cracking load for beams reinforced with AM could be attributed to the greater bond properties due to better surface rib configuration that allowed effective transfer of stresses between the reinforcing steel bar and its surrounding concrete and enabled the beam to resist deflection under a much higher load.
2. Beams reinforced with AM under monotonic loading failed under a much higher load of 64.6 KN, higher than beams reinforced with locally manufactured bars. Among the three locally manufactured bars, B5PL recorded the highest experimental failure load of 56 KN with FBML recording the next highest experimental failure load of 47 KN. STSL recorded the least experimental failure load of 38.5 KN. The impressive performance of B5PL-reinforced beams among the three locally manufactured reinforcements could be attributed to its high yield strength of 484.24 N/mm^2 , higher rib height of 1.138mm, and much smaller rib spacing of 8.857mm as compared to the other two locally manufactured bars. It could therefore be concluded that B5PL had a better bond performance in terms of resistance to deflection as compared with the other two locally manufactured reinforcements under monotonic loading.
3. Among the beams subjected to cyclic loading, AM again recorded the highest experimental failure load of 73 KN probably owing to its high tensile strength. Regarding the three locally manufactured bars, B5PL-reinforced beams again recorded the highest average experimental failure load of 55 KN, closely followed by FBML which recorded an average experimental failure load of 54 KN. STSL-reinforced beams however recorded the least experimental failure load of 41 KN. Therefore, B5PL among the three locally manufactured reinforcements again, had the best performance in terms of resistance to deflection under cyclic loading.

Disclaimer (Artificial intelligence)

Option 1:

Author(s) hereby declare that NO generative AI technologies such as Large Language Models (ChatGPT, COPILOT, etc) and text-to-image generators have been used during writing or editing of manuscripts.

REFERENCES

1. Ojha PN, Singh B, Singh P. Empirical equations for prediction of split tensile and flexural strength of high strength concrete including the effect of steel fiber. *Res. Eng. Struct. Mater.*, 2023; 9(1): 95-112.
2. Nawy, E.G. Reinforced Concrete: A Fundamental Approach., 6th Edn., Prentice Hall, New York, 2008, ISBN-13: 9780132417037.
3. BS 4449:2005+A2. Steel for the reinforcement of concrete – Weldable reinforcing steel bar-Bar, coil, and de-coiled product-Specification British Standard Institution; 2009.
4. ASTM A615: 1972, Standard Specification for Deformed and Plain Carbon-Steel Bars for Concrete Reinforcement.
5. GS 788-2:2018. Building and Construction Materials-Steel for the reinforcement of Concrete-Ribbed bars, Ghana Standard Authority; 2018.
6. Kankam C.K (2004), "Bond strength of reinforcing steel bars milled from scrap metals", *Materials and Design*, 2004; 25:231 - 238.
7. Buabin TK, Kankam CK, Meisuh B.K . (2017). Bond strength of reinforcing steel bars locally milled from scrap metals in concrete prepared with palm kernel shell as coarse aggregate. *International Journal of Engineering and Technical Research*, Vol 7, Issue 11, 2017; pp. 26-31.
8. Assiamah, Kankan CK, Banini EK, Appiah AK. Physical geometrical characteristics of reinforcing steel bars in the construction industry of Ghana. *Journal of Material Source*,

Research and Reviews, 2023, 11(1): 40-53.

9. Assiamah, Kankam CK, Banini EK, E S, Adinkrah-Appiah K. Bayesian analysis of physiochemical and mechanical characteristics of rebars in Ghana's construction industry. *Journal of Building Engineering*. Elsevier, 73(2023)106835.
10. Kankam CK, Adom Asamoah M. Strength and ductility characteristics of reinforcing steel bars milled from scrap metals. *Journal of Materials and Design*, Elsevier Science Limited. 2002;23: 537-545.
11. Quarm Junior J.K, Kankam C.K, Obuor P.T, Akortia VK, Banini E.K., Biney E., Adzakey P., and Dzivenu C.K. Strength and Deformational Characteristics of Concrete Beams Reinforced with Steel Bars Locally Produced from Recycled Metal Scrap in Ghana. *Journal of Engineering Research and Reports*. 2023. Vol. 24, Issue 12, Page 57-74.
12. Adom-Asamoah M. and Kankam C.K. Flexural behaviour of one-way concrete slabs reinforced with steel bars milled from scrap metals. *Materials & Design*. 2009. Vol 30, Issue 5, May 2009, Pages 1737-1742.
13. Kankam C.K and Adom-Asamoah M. Shear strength of concrete beams reinforced with steel bars milled from scrap metals. *Materials & Design*. 2006. Vol 27, Issue 10, 2006, Pages 928-934.
14. Biney, E., Kankam, C.K., Akortia, V.K., Adzakey, P., Junior, J.K.Q., & Tongyem, E. (2024). Examining the Geometrical Properties, chemical Composition, and Mechanical Properties of Local Reinforcing Bars in Ghana. *Journal of Engineering Research and Reports*, 2696), 223-240.

UNDER PEER REVIEW