

**MODEL OF TEACHERS' PERFORMANCE IN PUBLIC SCHOOLS OF PANABO CITY,
DAVAO DEL NORTE, PHILIPPINES: Teacher's Performance Triad- Exploring the Nexus of
Job Design, Commitment, and Satisfaction**

ABSTRACT

In the realm of educational management, teachers' performance is a crucial component in fulfilling the school's objectives, as it directly influences the quality of education provided to students. Performing teachers contribute significantly to achieving the institution's goals by ensuring students receive a high-quality education and reach their full potential. This study aimed to develop a best-fit model of job design characteristics, organizational commitment, and job satisfaction in line with teachers' performance at the Schools Division of Panabo City. It examined the variables that best predict teachers' performance and determined the best fit structural model. It utilized descriptive, correlational, and causal-comparative research design. This study is significant to Human Resource Management considering that findings were good inputs on developing a framework in improving teacher's performance. This framework would also be appropriate tool in identifying intervention programs like training, seminar-workshops and other related activities in line with human resource development program. It involved 490 elementary school teachers and utilized 4 sets of modified questionnaires on job design characteristics, organizational commitment, job satisfaction, and teacher performance, which were subjected to validity and reliability. The findings indicated a positive relationship between job design characteristics, and job satisfaction and are predictors of teacher performance with the equation $TP = 5.810 + 0.155 (JDC-M) + 0.168 (JS-TS)$. Moreover, the result concluded that the best fit structural model on teacher's performance is greatly anchored on these variables: job satisfaction and job design characteristics. It is recommended to have a policy framework in identifying the appropriate intervention programs in job satisfaction and job design characteristics to improve teacher's performance of Panabo City Division. Additionally, this recommends that the HRMO, Regional, Division and school Administrators as the implementing unit must have the capacity to identify appropriate tasks and offer technical assistance to the teachers of the school that falls under the jurisdiction of the department to organize informative workshops and seminars aimed at boosting the teachers' motivation and effectively addressing their concerns, particularly regarding promotions and benefits. Further, it needs to have a depth exploration of identifying factors on job satisfaction and job design characteristics for the improvement of the performance of teachers.

Keywords: *Job design characteristics, organizational commitment, job satisfaction, teacher's performance*

Introduction

An overview of scope and relevance of the research

Teachers are placed at the center stage of education, carrying crucial roles in achieving educational goals, which directly determine the quality of education. The fulfillment of their tasks and responsibilities is associated with various factors that influence their performance. Teachers' performance plays a vital role in the realization of goals of education and has an influence on the overall success of the school system (Darwami and Retnowati, 2019). It is linked with the outcomes in attaining the objectives of the educational institution (Andriani et al. 2018).

Recently, various studies have been conducted that affect teachers' performance. These studies include work environment, work motivation, and organizational culture (Sudibjo and Nasution, 2020); managerial skills and work motivation of principals (Roemintoyo et al., 2021); work motivation, work discipline and teachers' interpersonal communication (Hasbi Sjamsir, 2021) as well as teachers psychological capabilities like hope, optimism, and self-efficacy (Hudain et al., 2023). In the Philippines context, Sarabia and Collantes (2020) revealed that factors like gender, job position, seminar participation, and work demand level serve as predictors of performance among selected public school teachers. Additionally, Baluyos et al., (2019) indicated that teachers have a high level of job satisfaction and performed well however teacher satisfaction with school head supervision and job security has a negative impact on their work performance.

Teacher performance is pivotal for educational organizations, impacting their ability to achieve educational sector success. The Philippine Department of Education uses the Philippine Professional Standards for Teachers (PPST) to assess and manage teacher performance across seven key result areas (KRAs), including subject knowledge, inclusive learning environments, curriculum planning, assessments, community engagement, and ongoing professional development (Department Education, 2017). These factors collectively contribute to effective teaching and student success, with ongoing professional development being crucial in adapting to the changing educational landscape. As emphasized by Anggraeni & Nur (2021) assessing teacher's performance would lead to effective management, leadership, competitiveness, and professional growth and development.

While certain predictive factors have been identified, researches concerning job design characteristics and organizational commitment's influences on teacher satisfaction and performance has not been established in the Philippine context. Although Marzuqi (2021) found out that there are relationship between job design factors and factors of job satisfaction and organizational commitment among male and female teachers, it did not delve into relating it to their performance.

The purpose of this study was to explore how job design features, organizational commitment, and job satisfaction relate to the performance of elementary school teachers in Panabo Division. It also aimed to predict the key variables that greatly influenced teacher performance and developed a model that was tailored to the current educational system. This is significant as it provides valuable inputs for designing effective professional development activities in the DepEd's Human Resource Development Plan

Review of Related Literature

Job design characteristics

Job design characteristics are important components that shape the employee's role, aligning tasks and responsibilities with their individual abilities (Ali & Zia-ur-Rehman, 2014). Hackman and Oldham Model highlighted that teacher performance is significantly influenced by job design factors such as skill variety, task identity, task significance, autonomy, and feedback (Kiyani et al., 2018). Skill variety enhances empowerment among faculty and non-teaching personnel (Chidi et al., 2020), while task identity fosters employee's self-motivation and engagement (Azzam, 2018). Task significance influences job performance and reduces absenteeism, and autonomy empowers employees, boosting motivation and effectiveness (Allan, 2017; Kawasaki, 2019; Lennert Da Silva & Mølsted, 2020) while enhanced autonomy is linked with increased responsibility for personnel to plan and shape their own job roles, potentially causing stress if they lack adequate support (Dettmers & Bredehöft, 2020). In addition, feedback is crucial for motivating and enhancing employee productivity (Caingcoy et al., 2021; Hussein, 2020; Boerboom et al., 2015).

Organizational commitment

Teacher's organizational commitment is shown on the dedication and loyalty to their educational institution. This commitment is demonstrated through teachers' sincere concern for their students' well-being, aligning with ethical principles, values (Malik et al., 2017) and work goals (Jaiswa and Agarwa, 2019). This commitment can vary among teachers depending upon the efforts to lessen teachers' emotional exhaustion could significantly enhance teachers' commitment to their organization (Wullur & Werang, 2020). The three-component model (TCM) of Mayer and Allen identifies affective commitment, normative commitment, and continuance commitment as key indicators of organizational commitment (Khan & Rainayee, 2022). These components reflect an employee's emotional connection, sense of moral duty, and perceived costs associated with leaving the organization, respectively (Alrowwad et al., 2020). Teacher's affective commitment is characterized by strong emotional attachments as they actively engage with their educational institutions (Batugal, 2019) and has been found to predict increased dedication, job satisfaction, and sustained performance among teachers (Ingay, 2018). Normative commitment stems from a sense of moral obligation to the organization, and teachers with this commitment often stay due to internalized norms and benefits received (Poliquit et al., 2018) while continuance commitment, on the other hand, has found to be predictors of teachers are less likely to stay due to perceived costs such as retirement benefits (Tadesse, 2019) and strong sense of security and satisfaction among non-teaching personnel (Payod et al. 2021).

Job satisfaction

Job satisfaction is given emphasis by education institution to improve teachers' performance. It denotes to how employees perceive and respond to their jobs and the overall work environment, by considering factors such as engagement, respect, appreciation, fair compensation, motivation, and overall life satisfaction (Hussain et al., 2018). Wang and Dapat (2023) identified work engagement as a predictor of teachers' job satisfaction, which can be influenced by the principal's leadership style and organizational culture (Hidayat et al., 2020). On

the other hand, recognition from research achievement (Tacbalan et al., 2023) and how teachers are connected to each other and how often they seek academic advice from colleagues which can improve job satisfaction (Edinger and Edinger, 2018). Motivation can be associated with compensation (Guoba et al., 2022; Lie et al., 2021; Gius, 2013); and work security (Situma, 2015); which will affect job satisfaction and performance. Life satisfaction, which includes the overall well-being and happiness, is closely linked to job satisfaction. Teachers who are satisfied with their jobs tend to experience increased life satisfaction, which, in turn, contributes to a better quality of life (Dağlı and Baysal, 2017; Kadtong et al., 2017). In essence, Ballarta and Roberto, (2020) indicates that teachers who enjoyed a high level of job satisfaction were capable of efficiently justifying their responsibilities and excelling in their job performance.

Performance

Teachers' performance is evident as a result of attitude adjustment, increased motivation, and the presence of a positive organizational culture (Baluyos et al., 2019). This emphasis on teacher performance aligns with the Department of Education in the Philippines' focus on quality education through the development of the Philippine Professional Standards for Teachers (PPST). The PPST serves as the framework for assessing and managing teachers' performance, aiding in their professional development and the effective implementation of programs like the K to 12 Program. In fact, teacher evaluation, selection, and advancement are all anchored in these standards (Department Education, 2017).

The PPST identifies key result areas (KSAs) encompassing content knowledge and pedagogy, learning environment, diversity of learners, curriculum and planning, assessment and reporting, community linkages, and professional development, as well as personal growth and professional development. These areas underscore the importance of competence in various aspects of teaching.

This alignment between teacher performance and educational effectiveness is consistent with the findings of Ozgenel (2019) who identified the positive impact of teachers on school effectiveness. Moreover, Morales and Ventura (2022) underscored the significance of specific teacher attributes, such as advanced knowledge, skills, attitudes, and a comprehensive understanding of educational standards, as key factors influencing students performance.

Methods

This study investigated the relationship of job design characteristics, organizational commitment, and job satisfaction on teacher performance in public elementary schools in Panabo City. To gather data, four sets of validated questionnaires were employed, focusing on job design, organizational commitment, job satisfaction, and teacher performance indicators. The ten-point Likert scale questionnaires showed strong reliability, validated by Cronbach's Alpha coefficient analysis, yielding reliability coefficients of 0.945, 0.902, 0.921, and 0.951 for the respective questionnaires. It involved 490 proficient teachers from Panabo City's public elementary schools, who were from four district schools within the Panabo City Division. The data analysis in this study included the use of mean, Pearson Product Moment Correlation, Multiple Regression, and Structural Equation Modeling techniques.

Results, discussion and conclusion

This study focused on examining various aspects of job design, organizational commitment, job satisfaction, and teacher performance specifically among public elementary school teachers in the Panabo City Division. It sought to determine the significant relationship among these variables to teacher performance. Furthermore, this study aims to determine which of these variables have the most impact on teachers' performance and ultimately develop a model for predicting the performance of these educators.

Table 1

Level of Job Design Characteristics of Public Elementary School Teachers of Panabo City Division (N=490)

Job Design Characteristics	Mean Score	SD
Skill Variety	8.44	1.76
Task Identity	8.41	1.76
Task Significance	8.51	1.75
Autonomy	8.40	1.80
Feedback	8.59	1.82
Overall	8.47	1.78

Table 1 shows the job design characteristics perceived by elementary public-school teachers in Panabo City Division, including skill variety, task identity, task significance, autonomy, and feedback. Notably, feedback received the highest mean score of 8.59 with SD 1.82, signifying a very high level, followed closely by task significance at 8.51 and skill variety at 8.44. Task identity and autonomy also scored high, with 8.41 and 8.40, respectively. The lowest score was in autonomy pertaining to perceived constraints in decision making which will affect teachers' motivation and productivity. The high overall score of 8.47 with 1.78 SD indicates that teachers understand their job well and that their job design supports better job performance and productivity. They confer with the ideas of Ali and Zia-ur-Rehman,(2014) and Hussein (2020) that emphasizing job design helps clarify roles, reduce uncertainty, and motivate employees to complete tasks efficiently. In summary, effective job design characteristics play a crucial role in human resource management, fostering job satisfaction, boosting productivity and work performance.

Moreover, the teachers highlighted the importance of feedback in motivating and enhancing employee performance, as supported by Boerboom et al., (2015); Caingcoy et al.,(2021); Hussein, 2020). Conversely, when substantial job autonomy is provided without adequate organizational support, it can yield both favorable and unfavorable outcomes. This is

because increased autonomy places a greater burden on individuals to independently plan and decide their job roles, potentially causing stress if they lack the necessary support (Dettmers and Bredehöft, 2020).

Table 2

Level of Organizational Commitment of Public Elementary School Teachers of Panabo City Division

Organizational Commitment	Mean Score	SD
<i>Affective Commitment</i>	8.53	1.98
<i>Normative Commitment</i>	7.04	2.53
<i>Continuance Commitment</i>	6.67	2.80
Overall	7.41	2.44

Table 2 shows that variable Affective Commitment with a mean score of 8.53 described as very high, while Normative commitment with a mean score of 7.04 described as high, and Continuance Commitment with a mean score of 6.67 described as high and was the lowest among the three variables under organizational commitment. As an overall result of the teacher's organizational commitment with a mean of 7.41 with 2.44 SD indicates it is described as high in the level of their organizational commitment.

This suggests that teachers' robust commitment to their organization is illustrated by the emotional connection they have with their school. Batugal (2019) stressed the beneficial influence of strong emotional attachments, noting that they lead to active engagement with educational institutions. Research by Ingay (2018) has shown that these emotional bonds predict increased dedication, job satisfaction, and consistent performance among teachers. This finding is consistent with Payod et al. (2021) results that an employee's emotional connection to the institution is reinforced through strong sense of security and satisfaction and the more attachment to the institution.

Table 3*Level of Job satisfaction of Public Elementary School Teachers of Panabo City Division*

Job Satisfaction	Mean Score	SD
<i>Engagement</i>	8.73	1.94
<i>Respect, Praise & Appreciation</i>	8.25	1.93
<i>Fair Compensation</i>	8.27	2.07
<i>Motivation</i>	8.20	1.99
<i>Life Satisfaction</i>	8.25	2.07
Overall	8.34	2.00

Table 3 reveals that the job satisfaction level among teachers was very high, with an average score of 8.31 and a standard deviation of 2.0. This suggests that how school leaders organize the work environment significantly impacts both job satisfaction and a sense of job security. When teachers are actively engaged in their work and provided with opportunities for career growth, supportive relationships with management, and adequate resources, it leads to higher job satisfaction. Recognition, appreciation for their efforts, respect for their opinions, and involvement in decision-making processes further enhance their job contentment. This aligns with the concept that job satisfaction encompasses factors like engagement, respect, appreciation, fair compensation, motivation, and overall life satisfaction (Hussain et al.,2018).

Moreover, motivation is closely related to compensation, as indicated by Guoba et al., (2022), Lie et al., (2021) and Gius (2013). Teachers who are contented with their jobs tend to experience greater life satisfaction, contributing to an improved overall quality of life, as what Dağlı and Baysal (2017) and Kadtong et al.(2017) findings. Essentially, a well-organized work environment, recognition, and opportunities for career advancement all play vital roles in fostering high job satisfaction and, in turn, enhancing teachers' quality of life.

Table 4

Level of Teacher's Performance of Public Elementary School Teachers of Panabo City Division

Indicators	n	Mean	Standard Deviation
Content, Knowledge & Pedagogy		8.64	1.60
Learning Environment		8.68	1.55
Diversity of Learning		8.58	1.64
Curriculum & Planning		8.40	1.72
Assessment & Reporting		8.61	1.70
Community Linkages Professional Engagement		8.38	1.96
Personal Growth & Professional Development		8.71	2.05
Job Performance		8.58	1.74

In terms of Teachers' Performance, Table 4 shows that all indicators got the very high average weighted means. These included Personal Growth & Professional Development at 8.83, Learning Environment at 8.79, Content, Knowledge & Pedagogy at 8.73, Assessment & Reporting at 8.71, Diversity of Learning with an average mean of 8.67, Curriculum & Planning at 8.54, and the lowest average mean was for Community Linkages & Professional Engagement, which scored 8.50. In summary, the elementary public teachers in Panabo City Division provided an overall job performance rating of 8.58, indicating a very high level of performance, with a standard deviation of 1.74.

This shows that the teachers perform the different duties and responsibilities pertaining to their job. This implies that the high investment in training for pedagogy, learning environment, personal growth made a high teacher's performance. Moreover, better assessment and reporting in diverse learning that foster community participation in the job of the teachers increases better performance.

The findings is in consonance with the findings of Ozgenel (2019) in Istanbul, which indicated that the performance of teachers has a positive impact on school effectiveness. Furthermore, Morales and Ventura (2022) found out that certain attributes of teachers, such as advanced knowledge, skills, attitudes, and a thorough understanding of educational standards, play a crucial role in determining high performance in schools.

Table 5 *Relationship Between Job Design Characteristics and Teacher's Performance of Public Elementary School Teachers of Panabo City Division*

Job Design Characteristics	R	p-value Sig (2-tailed)	Decision (Ho)
<i>Skill Variety</i>	0.130	0.004	Reject
<i>Task Identity</i>	0.113	0.012	Reject
<i>Task Significance</i>	0.139	0.002	Reject
<i>Autonomy</i>	0.123	0.008	Reject
<i>Feedback</i>	0.124	0.006	Reject
Overall	0.135	0.003	Reject

*Correlation is significant at the 0.05 (2-tailed)

Table 5 investigated the relationship between job characteristics and the performance of elementary school teachers in Panabo City Division. By analyzing factors such as skill variety, task identity, task significance, autonomy, and feedback, the study found a significant and strong correlation (p-value = 0.003) between these job characteristics and teacher performance. Essentially, the way in which teachers approach their responsibilities and utilize their skills greatly impacts their overall performance. Additionally, aspects such as the importance of their role, recognition, perceived competence, and autonomy also have a positive influence on their performance. Therefore, it is crucial to have a well-structured job design system in place in order to significantly enhance teacher performance.

This findings support the ideas proposed by Kiyani et al. (2018), showing that teacher performance is greatly impacted by job design elements like skill variety, task identity, task significance, autonomy, and feedback, as outlined in the Hackman and Oldham Model.

Table 6 *Relationship Between Organizational Commitment and Teacher's Performance of Public Elementary School Teachers of Panabo City Division*

Organizational Commitment	r	p-value Sig (2-tailed)	Decision (Ho)
<i>Affective Commitment</i>	0.016	0.729	Accept
<i>Normative Commitment</i>	0.074	0.101	Accept
<i>Continuance Commitment</i>	0.049	0.283	Accept
Overall	0.062	0.173	Accept

*Correlation is significant at the 0.01 level (2-tailed)

Table 6 presents the relationship between three Organizational Commitment indicators and the performance of public elementary school teachers in Panabo City Division. The analysis revealed p-values of 0.729, 0.101, and 0.283 for these commitment indicators, respectively, indicating no correlation between them and teacher performance. The overall p-value of 0.173 further supports the absence of a significant relationship between Organizational Commitment and Teacher's Performance. This suggests that while teachers in Panabo City Division may have shown lower commitment levels to their profession, they continued to perform their teaching duties effectively. Their attitudes toward work, school goals, and organizational loyalty posed challenges, but these did not influence their job performance, as they remained committed to teaching, staying in the same school, and enhancing their performance.

This result contradicts with Ingay, (2018) study, which suggested that organizational commitment predicts increased dedication, job satisfaction, and consistent performance among teachers. In contrast, Erlangga et al. (2021) found a positive correlation between organizational commitment and teacher performance, where higher commitment led to improved performance, and lower commitment resulted in decreased performance.

Table 7 *Relationship Between Job Satisfaction and Teacher's Performance of Public Elementary School Teachers of Panabo City Division*

Job Satisfaction	r	p-value Sig (2-tailed)	Decision (Ho)
<i>Respect, Praise and Appreciation</i>	0.134	0.002	Reject
<i>Fair Compensation</i>	0.126	0.005	Reject
<i>Motivation</i>	0.147	0.001	Reject
<i>Life Satisfaction</i>	0.136	0.002	Reject
Overall	0.143	0.001	Reject

*Correlation is significant at the 0.05 level (2-tailed)

Table 7 reveals the results of a test investigating the relationship between Job Satisfaction indicators and Public Elementary School Teachers' performance in Panabo City Division. The findings indicate a significant correlation between the Job Satisfaction indicators and the teachers' performance. Specifically, the indicators of Engagement, Respect, Praise & Appreciation, Fair Compensation, Motivation, and Life Satisfaction were analyzed, with associated p-values of 0.010, 0.002, 0.005, 0.001, and 0.002, respectively. The overall p-value was 0.001, indicating a significant relationship between Job Satisfaction indicators and Teacher's Performance. These results suggest that teachers in Panabo City Division are highly motivated, fairly compensated, and receive recognition, contributing to job satisfaction, improved performance, and greater job retention, ultimately supporting their long-term teaching careers.

The results are in consonance with Ballarta and Roberto's 2020 study, which demonstrated that job satisfaction had a positive impact on teachers' performance.

Table 8 *The Predictors of Teacher's Performance of Public Elementary School Teachers of Panabo City Division.*

Interdependent Variables	Unstandardized Coefficients		Standardized Coefficients		
	B	Std. Error	Beta	T	Sig.
Constant	5.810	0.681		8.529	0.000
Job Satisfaction					
<i>Motivation</i>	0.155	0.053	0.131	2.914	0.004
Job Design Characteristics					
<i>Task Significance</i>	0.168	0.062	0.121	2.697	0.007

$r=0.190, r^2=0.036, F\text{-ratio}=9.127, p\text{-value}=0.000$

Table 8 displayed predictors for Teacher's Performance, showing a significant positive influence ($p < 0.05$) on Teacher's Performance. The model effectively explained 47.8% of the variance, with Motivation (Mo) for Job Satisfaction (JS) and Task Significance (TS) for Job Design Characteristics (JDC) as predictors of Teacher's Performance (TP) in the equation $TP = 5.810 + 0.155 (M) + 0.168 (TS)$. This suggests that increasing motivation and task significance by one unit corresponded to a 0.155 and 0.168 improvement in teacher performance, indicating that teachers in Panabo City Division could benefit from increased motivation to enhance their productivity and job satisfaction, as motivated teachers tend to willingly contribute to organizational tasks

This result corroborates with De Asis-Galvez (2018) study, which found that teachers were highly motivated in their job despite moderate stress levels and remained proud of their profession, performing well in school. Ángeles López-Cabarcos et al. (2022) supported the idea that task significance influences employee job performance.

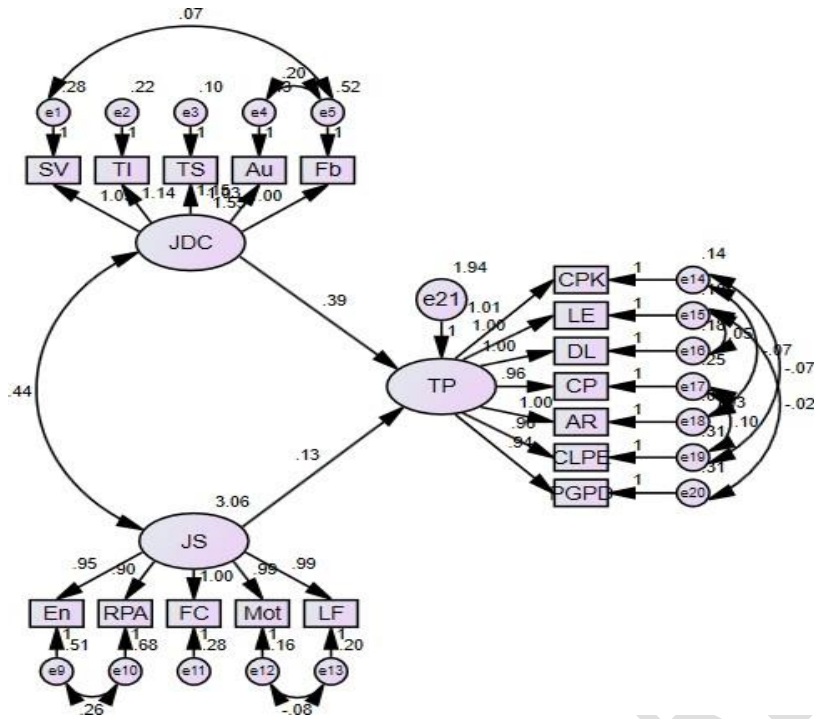

Figure 1. Best Fit Model

Legend:

JDC - Job Design Characteristics
 Appreciation SV - Skill Variety
 TI - Task Identity
 TS - Task Significance
 Au - Autonomy
 Fb - Feedback
 JS - Job Satisfaction
 En - Engagement

RPA - Respect, Praise &
 FC - Fair Compensation
 Mot - Motivation
 LF - Life Satisfaction
 TP - Teacher's Performance
 CPK-Content Knowledge & Pedagogy
 LE - Learning Environment
 CP-Curriculum & Planning
 CLPE-Community Linkages & Prof. Engagement
 PGPD-Personal Growth & Prof. Development

Figure 1 illustrates the cause-and-effect relationship between the independent variables, Job Design Characteristics (JDC) and Job Satisfaction (JS), and the dependent variable, Teacher's Performance (TP). It also presented the individual indicators within each of these variables. JDC included five indicators: Skill Variety (SV), Task Identity (TI), Task Significance (TS), Autonomy (Au), and Feedback (Fb). JS was comprised of five indicators: Engagement (En), Respect, Praise & Appreciation (RPA), Fair Compensation (FC), Motivation (Mot), and Life Satisfaction (LF). Furthermore, the figure depicted how these variables were interconnected, with Teacher's Performance (TP) encompassing

seven indicators: Content Knowledge & Pedagogy (CPK), Learning Environment (LE), Diversity of Learning (DL), Curriculum and Planning (CP), Assessment and Reporting (AR), Community Linkages and Professional Engagement (CLPE), and Personal Growth and Professional Development (PGPD). This model standardized solution revealed that the collective impact of the independent variables explained 1.94 units of the variance.

Table 9 *The Standardized Direct, Indirect and Total Effect Estimates of Structural Model 4*

Latent Variables	Direct Effect	Indirect Effect	Total Effect
<i>Job Design Characteristics</i>	0.394	0	0.394
<i>Job Satisfaction</i>	0.126	0	0.126

Table 9 presents the direct, indirect, and overall impacts of the independent variables on the dependent variables. In terms of the relationship with teacher's performance, the direct and overall impact of Job Design Characteristics was measured at 0.394, while Job Satisfaction had a direct and overall effect of 0.126. This suggests that while job satisfaction matters, the characteristics of job design have a more prominent and direct influence on teacher performance. However, both independent variables do have an influence on teacher performance, and the study highlights that teachers in Panabo City Division are effective and efficient, with high job satisfaction attributed to well-implemented job design, leading to improved performance in their work.

The study further reveals that highly satisfied teachers exhibit greater competence in their specific roles, displaying deep knowledge and expertise. This enhanced job satisfaction and overall performance align with previous study by Ballarta and Roberto (2020) emphasizing the prevalent job satisfaction among teachers, which helps them rationalize their responsibilities and perform efficiently.

Table 10. The Goodness of Fit Measures of Structural Model

INDEX	CRITERION	MODEL 1 FIT VALUE
CMIN/DF	<2.00	1.072
P-Value	>0.05	0.289
NFI	>0.95	0.995
TLI	>0.95	1.000
CFI	>0.95	1.000
GFI	>0.95	0.982
RMSEA	<0.05	0.010

Legend: CMIN/DF-Chi-Square/Degrees of Freedom Index
NFI - Normal Fit Index
TLI - Tucker-Lewis Index

CFI- Comparative Fit
GFI - Goodness of Fit
RMSEA -Root Mean Square of Error Approximation

To assess the effectiveness of the model, Table 10 provided criteria for evaluating various indicators that determine a good model. The findings indicated that this model fell short in meeting the requirements for the p- value, which should be below 0.05. Additionally, the Root Mean Square of Error Approximation (RMSEA) exceeded the threshold of 0.05, while the Root and Pclose values were below 0.05. On the other hand, several other indicators demonstrated a satisfactory model fit. These included the Chi-Square/Degrees of Freedom (CMIN/DF), Normal Fit Index (NFI), Tucker-Lewis Index (TLI), Comparative Fit Index (CFI), and Goodness of Fit Index (GFI).

The result showed that Teacher's Performance was best predicted by Task Significance and Motivation. Based from the result, which implied that the teachers of Panabo City Division theorized that their performance was best anchored on the task significance and motivation. This further explained that the teachers had a low level of task significance in the job they were assigned and inadequate sources of motivation resulted in decreased effectiveness among the teachers.

The result showed that Teacher's Performance was best predicted by Task Significance and Motivation. Based from the result, which implied that the teachers of Panabo City Division theorized that their performance was best anchored on the task significance and motivation. This further explained that the teachers had a low level of task significance in the job they were assigned and inadequate sources of motivation resulted in decreased effectiveness among the teachers.

In alignment of the findings, the research conducted by Gayomale-Sala, et al., (2020) and supported by Kumari and Kumar (2023) highlights the self-determined and non-self-determined motivation, along with the factors that influence teachers' motivation, have a substantial impact on teachers' job performance. Furthermore, Forson et al. (2021) corroborates these findings, emphasizing that both internal and external factors of motivation play a pivotal role in shaping a teacher's performance, with many teachers displaying high motivation levels and a strong commitment to excelling in their roles.

Furthermore, Aroosiya & Ali (2014) established a strong and positive correlation between job design and teachers' performance. The researchers also noted that task significance were particularly noteworthy aspects of high-quality performance. In addition, Paknezhad et al. (2018) identified significant associations between the job description, qualifications, and characteristics of teachers, all of which are key components of job design, and their performance.

Conclusion and Recommendations

In this study, the elementary school teachers in Panabo City exhibited an exceptional level of job design, indicating a high degree of satisfaction with the way their work is structured and organized. These teachers showcased a high level of job satisfaction, suggesting a strong sense of contentment and fulfillment in their professional roles. They displayed exclusive commitment and loyalty to their respective schools, emphasizing their dedication to the institution. Furthermore, the teachers demonstrated an exceptional level of performance and proficiency in their teaching capabilities, reflecting their effectiveness in the classroom. The study also found a significant

relationship between the teachers' Job Design Characteristics and Job Satisfaction indicators and their Teacher's Performance indicators. However, it is worth noting that there was no significant correlation between Organizational Commitment indicators and Teacher's Performance. In particular, Motivation (Mo) for Job Satisfaction and Task Significance (TS) for Job Design Characteristics were identified as strong predictors of Teacher's Performance (TP), as represented by the equation $TP = 5.810 + 0.155 (M) + 0.168 (TS)$. Motivation and task significance emerged as the critical factors significantly influencing teacher's performance.

It is recommended that the Department of Education's (DepEd) Human Resource Department should consider implementing the framework proposed in this study to enhance teachers' job performance, with a focus on motivation and task significance. Regional and Division Administrators are urged to actively assist school administrators and teachers, organizing learning and development activities to boost teacher motivation and address issues related to promotions and benefits. School administrators should explore various strategies to increase teacher motivation, aligning teacher goals with those of the school and incentivizing teachers through promotions and benefits. Future research should further investigate motivational and task significance factors influencing teacher performance, aiming to identify additional predictors and analyzing elements that either facilitate or hinder teachers' performance

Disclaimer (Artificial intelligence)

Option 1:

Author(s) hereby declare that NO generative AI technologies such as Large Language Models (ChatGPT, COPILOT, etc) and text-to-image generators have been used during writing or editing of manuscripts.

Option 2:

Author(s) hereby declare that generative AI technologies such as Large Language Models, etc have been used during writing or editing of manuscripts. This explanation will include the name, version, model, and source of the generative AI technology and as well as all input prompts provided to the generative AI technology

Details of the AI usage are given below:

1. none

References

- Ali, N., & Zia-ur-Rehman, M. (2014). Impact of Job Design on Employee Performance, Mediating Role of Job Satisfaction: A Study of FMCG's Sector in Pakistan. *International Journal of Business and Management*, 9(2), p70. <https://doi.org/10.5539/ijbm.v9n2p70>
- Allan, B. A. (2017). Task significance and meaningful work: A longitudinal study. *Journal of Vocational Behavior*, 102, 174–182. <https://doi.org/10.1016/j.jvb.2017.07.011>
- Alrowwad, A., Almajali, D. A., Masa'Deh, R., & Obeidat, B. (2020). *The Role of Organizational Commitment in Enhancing Organizational Effectiveness*.
- Andriani, S., Kesumawati, N., & Kristiawan, M. (2018). *The Influence Of The Transformational Leadership And Work Motivation On Teachers Performance*. 7(7).
- Ángeles López-Cabarcos, M., Vázquez-Rodríguez, P., & Quiñoá-Piñeiro, L. M. (2022). An approach to employees' job performance through work environmental variables and leadership behaviours. *Journal of Business Research*, 140, 361–369. <https://doi.org/10.1016/j.jbusres.2021.11.006>
- Anggraeni, N., & Nur, S. N. (2021). *EFFORTS TO IMPROVE TEACHER PERFORMANCE: A THEORETICAL REVIEW*. 1(7).
- Aroosiya, M. A. C. F., & Ali, M. A. M. H. (2014). Impact of job design on employees' performance (with special reference to school teachers in the Kalmunai Zone). *Journal of Management*, 8(1), 33. <https://doi.org/10.4038/jm.v8i1.7553>
- Azzam, A. A. (2018). *Job Design Dimensions And Its Impact On Knowledge Sharing Among Employees In Jordanians Hospitals In Irbid District – Jordan*. <https://doi.org/10.5281/ZENODO.1186830>
- Ballarta, J. T., & Roberto, J. T. (2020). Job Satisfaction and Teaching Performance of Basic Education Teachers in Catholic Schools. *Philippine Social Science Journal*, 3(2), 57–58. <https://doi.org/10.52006/main.v3i2.162>

- Baluyos, G. R., Rivera, H. L., & Baluyos, E. L. (2019). Teachers' Job Satisfaction and Work Performance. *Open Journal of Social Sciences*, 07(08), 206–221.
<https://doi.org/10.4236/jss.2019.78015>
- Batugal, M. L. C. (2019). Organizational Culture, Commitment and Job Satisfaction of Faculty in Private-Sectarian Higher Education Institutions (HEIs). *World Journal of Education*, 9(2), 123. <https://doi.org/10.5430/wje.v9n2p123>
- Boerboom, T. B. B., Stalmeijer, R. E., Dolmans, D. H. J. M., & Jaarsma, D. A. D. C. (2015). How feedback can foster professional growth of teachers in the clinical workplace: A review of the literature. *Studies in Educational Evaluation*, 46, 47–52.
<https://doi.org/10.1016/j.stueduc.2015.02.001>
- Caingcoy, M. E., Pacursa, J. L., & Adajar, Ma. I. W. (2021). Effectiveness of the Alternative Learning System Informal Education Project and the Transfer of Life Skills among ALS Teachers: A Case Study. *International Journal of Community Service & Engagement*, 2(3), 88–98. <https://doi.org/10.47747/ijcse.v2i3.298>
- Chidi, O., Faith, Helen, O., Chibuokem, & Tochukwu, I., Titus. (2020). Job Design and Sustainability of Tertiary Institutions in South East, Nigeria. *Asian Journal of Education and Social Studies*, 37–45. <https://doi.org/10.9734/ajess/2020/v11i130282>
- Dağlı, A., & Baysal, N. (2017). Investigating Teachers' Life Satisfaction. *Universal Journal of Educational Research*, 5(7), 1250–1256. <https://doi.org/10.13189/ujer.2017.050717>
- Darwami, H. S., & Retnowati, R. (2019). Using Scientific Identification Theory for Operational Research in Education for analyzing Teachers' Performance. *International Journal of Managerial Studies and Research*, 7(4). <https://doi.org/10.20431/2349-0349.0704003>
- De Asis-Galvez, G. (2018). Work Motivation and Awards Received, and Pupils' Academic Performance in Elementary Schools in the Division of Northern Samar. *KnE Social Sciences*, 3(6), 522. <https://doi.org/10.18502/kss.v3i6.2402>

Department Education. (2017). *National adoption and implementation of The Philippines Professional Standards for Teachers*.

Dettmers, J., & Bredehöft, F. (2020). The Ambivalence of Job Autonomy and the Role of Job Design Demands. *Scandinavian Journal of Work and Organizational Psychology*, 5(1), 8. <https://doi.org/10.16993/sjwop.81>

Edinger, S. K., & Edinger, M. J. (2018). Improving Teacher Job Satisfaction: The Roles of Social Capital, Teacher Efficacy, and Support. *The Journal of Psychology*, 152(8), 573–593. <https://doi.org/10.1080/00223980.2018.1489364>

Erlangga, H., Mulyana, Y., Sunarsi, D., Solahudin, M., Dwiwarman, A., Waskita, N. I. D., Rozi, A., & Yuangga, K. D. (2021). The Effect of Organizational Commitment and Work Environment on Job Satisfaction and Teachers Performance. *Turkish Journal of Computer and Mathematics Education (TURCOMAT)*.

Forson, J. A., Ofosu-Dwamena, E., Opoku, R. A., & Adjavon, S. E. (2021). Employee motivation and job performance: A study of basic school teachers in Ghana. *Future Business Journal*, 7(1), 30. <https://doi.org/10.1186/s43093-021-00077-6>

Gayomale-Sala, M., Cordevilla, R., Mele, C., & Futralan, M. C. (2020). Motivational factors in relation to teachers' performance. *IJRDO - Journal of Social Science and Humanities Research*.

Gius, M. (2013). The effects of merit pay on teacher job satisfaction. *Applied Economics*, 45(31), 4443–4451. <https://doi.org/10.1080/00036846.2013.788783>

Guoba, A., Žygaiteienė, B., & Kepalienė, I. (2022). Factors Influencing Teachers' Job Satisfaction. *Journal of Humanities and Social Sciences Studies*, 4(4), 234–241. <https://doi.org/10.32996/jhsss.2022.4.4.30>

Hasbi Sjamsir, U. H. (2021). Factors Influencing Teachers' Performance in Junior High School. *Turkish Journal of Computer and Mathematics Education (TURCOMAT)*, 12(6), 2058–2071. <https://doi.org/10.17762/turcomat.v12i6.4810>

- Hidayat, D., Maitimo, V. V. S., & Suwu, S. E. (2020). Increasing Teachers' Work Engagement Through Servant Leadership, Organizational Culture, and Job Satisfaction. *Jurnal Pendidikan Dan Pengajaran*, 53(1), 90. <https://doi.org/10.23887/jpp.v53i1.24911>
- Hudain, M. A., Khasanah, F., Pramono, S. A., Haryanto, D., & Kamaruddin, I. (2023). The Influence of Psychological Capital, Certification Status and Work Resources on Teachers Performance. *Journal on Education*, 5(4), 11977–11982. <https://doi.org/10.31004/joe.v5i4.2156>
- Hussain, M. A., Ghouri, M. W. A., Hassan, M., Kanwal, T., & Rashid, M. (2018). Impact of Job Design on Employee's Satisfaction Level in Pakistan. *Advances in Social Sciences Research Journal*, 5(1). <https://doi.org/10.14738/assrj.52.4140>
- Hussein, A. (2020). Effect of Job Characteristics on Job Performance among Employees in the General TV Channels. *International Journal of Academic Research in Business and Social Sciences*, 10(9), Pages 333-344. <https://doi.org/10.6007/IJARBSS/v10-i9/7745>
- Ingay, A. B. (2018). *Leadership Practice and Work Commitment of Elementary School Heads as Determinants of Teachers' Morale in Davao Region*. 9(1).
- Jaiswa, S., & Agarwa, N. (2019). A study at organizational commitment of educator in school. *International Journal of Multidisciplinary Education and Research*, 4(1), . 39-41.
- Kadtong, M. L., Unos, M., Antok, T. D., & Midzid, M. A. E. (2017). Teaching Performance and Job Satisfaction Among Teachers at Region XII. *SSRN Electronic Journal*. <https://doi.org/10.2139/ssrn.3169846>
- Kawasaki, S. (2019). Effects of Psychological Need Satisfaction on Proactive Work Behaviors. *MinnesotaStateUniversity,Mankato*.
- Khan, A., & Rainayee, R. A. (2022). Organisational Commitment: Conceptualization, Measurement, and Scale validation. *International Journal of Science Technology and Manasgement*, 11(10).

- Kiyani, A. A., Ayupp, K., & Rasool, S. (2018). Construct validation of job characteristics in an Asian Context: An evidence among Academicians in private universities in Pakistan. *International Journal of Business and Society*, 19(3), 816–832.
- Kumari, J., & Kumar, J. (2023). Influence of motivation on teachers' job performance. *Humanities and Social Sciences Communications*, 10(1), 158.
<https://doi.org/10.1057/s41599-023-01662-6>
- Lennert Da Silva, A. L., & Mølsted, C. E. (2020). Teacher autonomy and teacher agency: A comparative study in Brazilian and Norwegian lower secondary education. *The Curriculum Journal*, 31(1), 115–131. <https://doi.org/10.1002/curj.3>
- Lie, D., Sherly, S., Dharma, E., Wakhyuni, E., & Sudirman, A. (2021). Reflections on Teacher Job Satisfaction: The Role of Principal Supervision, Organizational Culture, Motivation, and Compensation. *Jurnal Organisasi Dan Manajemen*, 17(2), 234–248.
<https://doi.org/10.33830/jom.v17i2.1302.2021>
- Malik, W. U., Javed, M., & Hassan, S. T. (2017). Influence of transformational leadership components on job satisfaction and organizational commitment. *Pakistan Journal of Commerce and Social Sciences (PJCSS)*, 11(1), 147–166.
- Marzuqi, F. S. M. (2021). The impact of job design on Job Commitment and job satisfaction among teachers in AL Batinah Governorate North, Sultanate of Oman. *IJASOS-International E-Journal of Advances in Social Sciences*, 7(19).
<https://doi.org/10.18769/ijasos.929063>
- Morales, G. A., & Ventura, E. C. (2022). Occupational stress and coping styles in relation to job performance of teachers in elementary schools in zone III Division of Zambales, Philippines. *International Journal of Education Humanities and Social Science*, 05(01), 154–163. <https://doi.org/10.54922/IJEHSS.2022.0352>
- Ozgenel, M. (2019). The role of teacher performance in school effectiveness. *International Journal of Education Technology and Scientific Researches*.

- Paknezhad, M., Balash, F., Mokhtar, M., & Alipuoer, S. (2018). The effect of job design on the teachers' performance using Achieve Model. *American Scientific Publishers*, 24(1), 77–79.
- Payod, E. P., Canque, M. S., & Derasin, L. M. C. (2021). Organizational Commitment of a Non-Teaching Personnel in a State University in the Philippines. *Turkish Journal of Computer and Mathematics Education (TURCOMAT)*, 12(14), 583–589.
- Poliquit, W. M., Ferrater-Gimena, J. A. O., & Gamaya, J. C. (2018). *Grasping the Organizational Commitment of Employees in a Higher Educational Institution in the Philippines*. 9(7).
- Roemintoyo, R., Tauhid, H., Miyono, N., & Budiarto, M. K. (2021). Contribution Factors in Affecting Teacher Performance: Principal Managerial Skills and Work Motivation. *Journal of Education Technology*, 5(2). <https://doi.org/10.23887/jet.v5i2.34687>
- Sarabia, A., & Collantes, L. M. (2020). Work-Related Stress and Teaching Performance of Teachers in Selected School in the Philippines. *Indonesian Research Journal in Education |IRJE|*, 6–27. <https://doi.org/10.22437/irje.v4i1.8084>
- Situma, R. N. (2015). Motivational factors affecting employees performance in public secondary schools in Bungoma North Sub County Kenya. *International Academic Journal of Human Resource and Business Administration*, 1(5), 140–161.
- Sudibjo, N., & Nasution, R. A. (2020). Work environment, work motivation and organizational culture in influencing teachers' performance. *Jurnal Pendidikan Dan Pengajaran*, 53(3), 276. <https://doi.org/10.23887/jpp.v53i3.28533>
- Tacbalan, A. D., Alcalde, A. P., & Modina, E. P. (2023). An Analysis of the variables influencing job satisfaction and the self-efficacy of the teachers. *International Journal of Research and Innovation in Social Science*, VI, 773–782. <https://doi.org/10.47772/IJRISS.2023.7661>
- Tadesse, E. F. (2019). *Teachers' Organizational Commitment at Secondary School in Addis Ababa, Ethiopia*. 7(4).

Wang, F., & Dapat, R. (2023). Teacher Self-efficacy, Work Engagement, and Job Satisfaction toward Teacher Development Program. *International Journal of Education and Humanities*, 7(2), 134–138. <https://doi.org/10.54097/ijeh.v7i2.5520>

Wullur, M. M., & Werang, B. R. (2020). Emotional exhaustion and organizational commitment: Primary school teachers' perspective. *International Journal of Evaluation and Research in Education (IJERE)*, 9(4), 912. <https://doi.org/10.11591/ijere.v9i4.20727>

UNDER PEER REVIEW