

Review of Terahertz spectroscopy in the field of food safety

Abstract:with the continuous improvement of people's living standards, food quality and safety problem has caused the wide attention of the whole society, the traditional food quality detection method has certain limitations, terahertz spectral technology (THZ) is a new spectral detection technology, its strong perspective, efficient spectral resolution ability, special fingerprint and nondestructive, in the field of food quality and safety detection has important application value. Due to the high efficiency of food quality and the need for accurate nondestructive testing, automated nondestructive testing for food quality and safety has aroused great interest from the food sector. Faster, accurate, reliable and simplified techniques are needed to classify good quality. **With their unique low-energy, penetrating, rapid and non-destructive techniques are widely used as a non-destructive and cost-effective method in the food sector.** This paper summarizes the principles and instruments of terahertz spectrum, and introduces the research progress of terahertz spectral detection in food, analyzes the problems in the field of food quality and safety detection, and discusses the future development trend of terahertz spectral technology.

Key words:terahertz time domain spectrum; spectral detection; food safety; non-destructive

Introduction

Due to the rapid development of the society, people begin to pursue a higher quality of life. Consumer awareness and demand for quality food make the safety monitoring and quality assessment of the food industry develop towards a reliable, accurate and rapid method^[1]. The quality evaluation process in some food industries is still manual by trained personnel, which is a tedious, time-consuming, expensive and complex process. Many precise but destructive methods have been invented to obtain the quality of the produce, but the subjective methods are very easy to go wrong. On the other hand, many other quality detection methods require professionals to use chemical reagents to extract and separate, preprocess, complicated operation, complicated sample preparation, excessive cost and destroy the samples. Therefore, automated non-destructive quality assessment methods are gaining popularity by reducing waste, improving efficiency and improving quality assessment techniques^[2]. Research to develop nondestructive quality evaluation methods is ongoing. Among them, spectroscopy and imaging are the two main optical technologies, with the application of^[3-6] in food safety and quality detection.

Spectroscopy (ultraviolet, near-infrared, MIR, visible light and Raman chemical imaging), isotope analysis, chromatography, thermal analysis have been successfully applied in the food industry. However, as an emerging technology, THz has its unique characteristics

compared with NIR. IR are less tolerant to irregularly shaped foods and are prone to scattering effects, making them unsuitable for sensing application^[7].

Terahertz (THz) waves are located in the frequency range of the electromagnetic spectrum between 0.1-10THz (wavelength 3mm-30 μ m), located between infrared and microwave wavelengths, and in a special position. It has the dual nature of electronics and photonics. Therefore, Terahertz spectroscopy has some unique properties compared with other spectroscopy technologies. Traditional methods such as X-ray and microwave may not be able to provide some information about sensing, and Terahertz can be used to obtain such information^[8]. THz technology may be used for food safety detection due to its transience, high permeability, wide band, coherence and low functionality. In recent years, the rapid development of semiconductor and ultrafast laser technology has solved the problem of terahertz radiation source and detector, and promoted the application of THz technology. Among them, it has broad application prospects in biomedicine^[9], national defense^[10], remote sensing^[11], security^[12]. In recent years, researchers have found that the high absorption of polar materials (such as water, ethanol and sugar) makes it possible to use polar materials in quantitative solutions^[13-14]. Second, it can penetrate many common physical barriers, such as packaging materials, which allows terahertz waves to be used for defect identification purposes. THz waves can be used to identify defects in finished products for real-time production applications^[15]. Terahertz technology has gradually demonstrated its potential and advantages in the field of food safety. From the point of view of food safety nondestructive testing, this paper introduces the principle of THz spectroscopy, reviews the achievements of THz technology in food safety field, and summarizes the application of THz technology in harmful residues, including foreign residues, antibiotic residues, mycotoxin residues and pesticide residues.

1. Terahertz spectroscopic techniques

Terahertz spectroscopy is a technique for material analysis and detection using electromagnetic waves in the terahertz (THz) band (frequency range usually between 0.1 and 10 THz). THz wave is between infrared and microwave, with coherence, absorption, low energy, nondestructive, transient state, high resolution, suitable for non-destructive detection and material characterization^[16].

1.1 Principle of terahertz time-domain spectroscopy techniques

The terahertz wave frequency range is 0.1-10 THz, with a wavelength range of 0.03-3 mm. This frequency band lies between microwave (MW) and infrared (IR) radiation in the electromagnetic spectrum, forming a bridge between the two. It is located in the middle region of electronics and photonics^{[17][18]}, and the superior characteristics of both light and electricity make up for the "terahertz gap"^[19], which plays an important role in the study of material absorption characteristics. Before the 1990s, due to the technical bottleneck of terahertz source and detection technology, the terahertz frequency band has not been fully developed and utilized. With the technological breakthrough of femtosecond laser and the rapid development of high-speed photoconductive materials, terahertz technology has ushered in a

large range of application and become a new research hotspot in the 21st century. Within this frequency band, many naturally occurring substances exhibit different absorption characteristics, forming unique absorption peaks that can be regarded as the "fingerprint" spectrum of matter. Terahertz spectroscopy is very sensitive to the vibration, rotational and vibrational energies of biomolecules, because the vibration frequencies of these molecules are exactly within the THz frequency range. Terahertz spectroscopy uses matter to measure the absorption, transmission and scattering of terahertz radiation to obtain information about matter. Different substances have different molecular structures and chemical components, so their absorption characteristics in the terahertz spectra will also be different. This technology has wide applications in biomedicine, materials science and safety testing, and can be used in the identification and detection of biomolecules, drug development, pathological tissue diagnosis and non-invasive biological imaging. Overall, THz spectroscopy is able to provide the fingerprint characteristics of matter, thus helping us to gain insight into the structure, composition, and properties of matter.

1.2 Generation of THz waves

In terms of the research category, the theory and technology of microwave have been mature in recent years, and the infrared theory and technology are gradually being improved, and there is still a big gap in the technical application and theoretical exploration of terahertz band. With the development of technology, researchers have found that different THz excitation modes have different electromagnetic wave bandwidth. At present, the optical methods that can stimulate broadband THz wave mainly include photoconductive antenna technology and optical rectification effect.

The basic principle of photoconductive antenna technology is that the photoconductive material can excite electrons and generate electron-hole pairs. Then, under the action of an applied electric field, electrons and holes move to form a current, which realizes the optical signal to an electrical signal. Photoelectric conductivity material characteristic is very important to the performance of radiation source, among them, the low temperature growth of gallium arsenide (LT-GaAs), indium phosphide (InP) and defective silicon (Si) wafer commonly used materials, its gap width, carrier mobility and life, the generation of terahertz radiation efficiency and spectrum characteristics has a direct and key role.

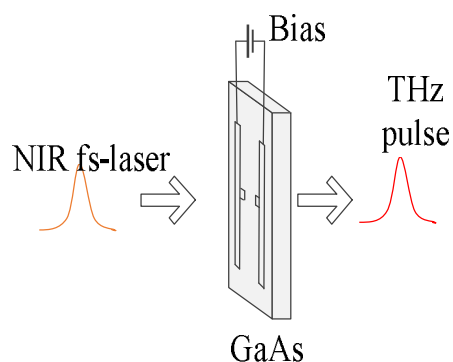

Fig. 1 Schematic diagram of terahertz radiation generated by photoconductive antenna
Optical rectification effect Photorectification radiation is a widely used technology in the field

of terahertz wave generation, whose core is the nonlinear optical effect. Light produces electron-hole pairs on the photoconducting material, and the nonlinear behavior of the material causes the current to flow in only one direction, and the light intensity changes the current size and direction, thus realizing signal modulation.

Compared with the photoconductive antenna technology, the photorectification method does not require the action of forbidden band transition and external electric field, and the device is relatively simple and does not require a complex electrode structure. In addition, the optical rectification method can withstand higher pump power while the hardware equipment is not damaged, and has high scalability. However, the sensitivity of the optical rectification effect is low, which may not detect very weak signals, and can only work in a specific frequency range, which is not suitable for the application scenarios of wide band.

1.3 Principle of the THz time-domain spectral system

The THz time domain spectral sampling system is a typical pulse wave system. A schematic structure of the THz temporal spectral sampling system is shown in Figure 2. The terahertz time domain spectrum system consists of femtosecond ultrafast laser emitter (Femtosecond pulsed laser), terahertz wave emitter (Generation of THz), terahertz wave receiver (Detection of THz), time delay controller (Optical delay) and other modules. The basic principle is that the femtosecond laser pulse emitted by the pump laser is divided by the spectrolens to form two different beams. All the way, it directly acts on the photoconductive material gallium arsenide, thus stimulating the electromagnetic pulse in the terahertz frequency band. The other route, as a detection light, is adjusted by the optical delay element, converges with the terahertz pulse in the collinear path, and is detected through the terahertz detection element. To achieve the precise regulation of the time difference between the detection light and the pump light, the time delay system uses multiple reflective prisms to increase the propagation path of the detection light, thus adjusting the light path difference between the detection light and the pump light. It is noteworthy that the size of the optical path difference is usually closely related to the thickness of the tested sample, and by adjusting the optical path difference, it can effectively reduce or eliminate the time difference between the two. The resulting terahertz wave is received on the detector, obtaining the change of the terahertz pulse electric field intensity in the time axis, the terahertz signal will delay and the decay of the amplitude^[20]. After the Fourier transform processing, the time domain waveform received by the detector can be converted into the frequency domain spectrum. By comparing the frequency domain spectral lines of the pump light and the detection light, we can obtain the relevant optical information, and obtain the refractive index, reflectivity and absorption coefficient that can represent the physical structural information and chemical properties of the tested sample through the extraction of optical parameters.

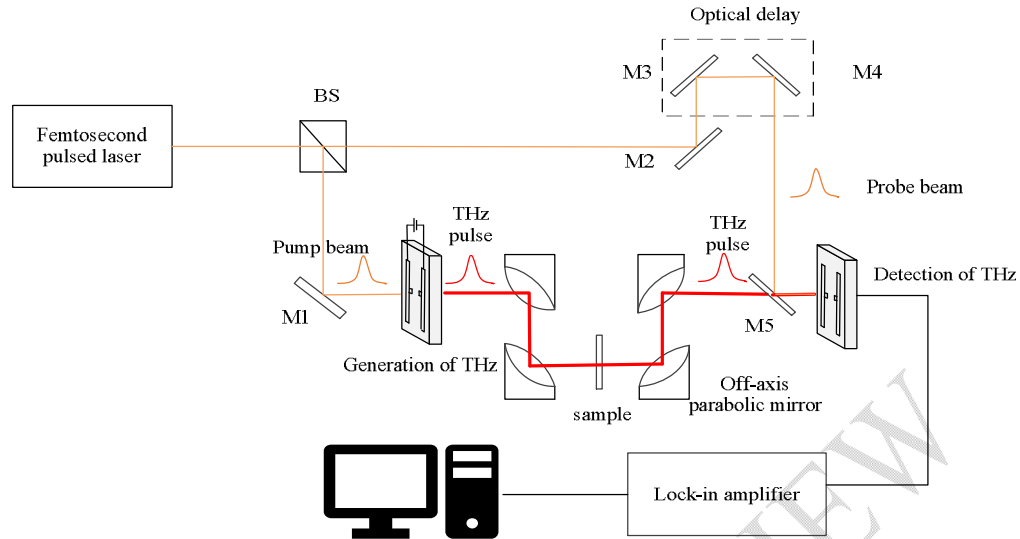

Fig. 2 Structure diagram of terahertz time domain spectroscopy system

2 Application of terahertz technology in food safety testing

At present, food safety has become one of the hot issues of concern, harmful residues **in food** quality and safety. Harmful residues mainly include foreign body residues, antibiotic residues, mycotoxin residues and pesticide residues.

2.1 Resiof foreign body

OK^[21] performed food detection using polygons and f-thetha lenses in the Asia-Pacific Hertz transmission imaging system and showed a fast scanning speed of 80 mm/s, high resolution at 210 GHz and a detection range of approximately 150 mm. Shin^[22] used complex refractive index mapping in THz-TDS (frequency 0.2-1.3 THz) to identify insects as foreign bodies in a variety of food products. Using the mapping concept, the refractive index and absorption coefficients of different insects are equivalent. However, in THz imaging, insects can be detected from food products. In addition, THz reflection and imaging techniques identified yellow mealworms in sugar, rice, and salt. A new method to distinguishing food materials from foreign bodies such as insects based on dielectric traces was implemented in a frequency range of 0.3-1.2 THz. Even for impurities such as wheat husk, wheat straw, wheat leaves, wheat grains, weeds and ladybugs, Shen^[23] used terahertz frequency domain imaging combined with wheat V2 convolution neural network (CNN) model, and the identification accuracy was 97.83% in the range of 0.2-1.6 THz, proving the feasibility of terahertz technology in detecting foreign body residues in food. Hu^[24] used CARS, UVE and SPA algorithms to extract the spectral features of foreign bodies in fish and optimized the model, achieving the prediction set accuracy of 99.56%. The visualization and analysis of the THz images of samples within 0.14.0 THz enabled the visualization of foreign bodies of fish using THz technology. Ge^[25] used terahertz spectroscopy and a deep support vector machine

(DSVM) to detect five heavy metal contaminants, namely arsenic, lead, mercury, chromium and cadmium, in wheat samples. Compared with the deep neural network (DNN) and SVM models, the comprehensive evaluation index optimized by DSVM has the highest accuracy of 91.3%, which improved the classification accuracy of heavy metal pollutants in wheat. Demonstrated the feasibility of terahertz technology in detecting foreign body residue in food products.

2.2 Antibiotic residues

Antibiotics and their harmful residues have been of great concern in recent years. Tetracycline hydrochloride Tetracyclinehydrochloride (TCH) is an antibiotic widely used for the treatment and prevention of microbial infections in animals. Qin^[26] attempted to detect and quantify TCH in powder and solution samples using THz in the 0.4 – 2.0 THz range using TDS and PLSR. Tetracycline hydrochloride(TC-HCl) is cheap, stable, easy to be absorbed, and easy to decompose into tetracycline(TC). The results showed that the PLSR model of powder samples was very successful in controlling the TC with $R_c = 0.9972$, $RMSEC = 1.31\%$, $R_{cv} = 0.9919$, $RMSECV = 2.23\%$, and $RPD = 7.87$. However, the PLSR model is not robust to solution samples and needs to be improved in the future. Qin^[27] incorporated the **attenuated total reflection**(ATR) technique into the THz-TDS to determine the complex refractive index of the tetracycline hydrochloride (TCH) solution. They tried to build a model at 0.5 THz and SLR to predict TCH concentration, and found that the developed models had high R^2 values (0.95 - 0.98) and lower RMSE values (0.61 - 0.99 mg/mL), with a low detection limit (LOD) ranging from 0.45 to 1.29 mg / mL. The results showed that **attenuated total reflection terahertz time-domain spectroscopy**(ATR THz-TDS) can achieve the conventional THz-TDS in liquid samples difficult to determine due to high absorbance in the THz region. Moreover, for the strong localization and enhancement field of metamaterials, Qin^[28] demonstrated that a metamaterials, consisting of a set of ring holes deposited on a metal film, can act as highly sensitive sensors to detect trace **tetracycline hydrochloride**(TCH) in aqueous solutions (as small as 0.1 mg/L). About 105-fold higher compared to those measured in silico, comparable to the maximum residue limit of **Tetracycline**(TC) antibiotics in the food matrix. Demonstrate the potential of THz technology in detecting antibiotic residues in food products. The optimal imaging frequency was obtained by quantitative assessment by **Backpropagation Neural Network**(BPNN), Bai^[29] used THz spectroscopy and imaging techniques for quantitative assessment using **Backpropagation Neural Network**(BPNN) to obtain the optimal imaging frequency. The relationship between the gray value and the concentration of the different mixtures at the optimal imaging frequency was established. The binary mixture of **fluoroquinolones (FQs)** with different concentrations in **fish meal feeds (FMF)** showed the best imaging and high precision at the characteristic absorption frequency of 0.825 THz. Zhang^[30] designed a structure-specific multi-band terahertz (THz) metamaterial sensor (TMS) and proposed a multi-resonance response competition and selection fusion (MRR-CSF) framework. The designed TMS, combined with the proposed MRR-CSF framework, improved the detection accuracy of enrofloxacin (ENR), pefloxacin (PEF) and nanorfloxacin (NAD) by 21% 27%, 13% 17% and 12% 13%, respectively. The detection limit of 5 ng/L for ENR, PEF, and NAD antibiotic solutions yielded a reliable recovery range of $100\% \pm 25\%$,

mean recovery>90%, and relative standard deviation values<5%.

2.3 mycotoxin residue

Fungal contamination is widespread, but its primary concern is concerned with safety. Aflatoxin is a mycotoxin mainly produced by fungi, and is widely found in agricultural products and food products. Ge^[31] used terahertz time-domain spectroscopy (THz-TDS) at 0.4 to 1.6 THz and quantitatively quantified the concentration of aflatoxin B1 in acetonitrile solution using linear (partial least squares (PLS), principal component regression (PCR)), and nonlinear (support vector machine (SVM), and PCA-SVM methods) regression models. The results showed that the linear regression model was better than the nonlinear regression model in the aflatoxin B1 concentration range from 1 to 50 μ g/mL, while the nonlinear regression model was more accurate from 1 - 50 μ g/mL, laying the foundation for the application of THz technology in food mycotoxin detection. Liu^[32] used Terahertz time-domain spectroscopy (THz-TDS) combined with Backpropagation Neural Network (BPNN) and t-distributed random 0.1-2.5 THz to detect aflatoxin B1 more than 2 μ g/kg in soybean oil with 90% accuracy, demonstrating the potential of THz technology in the quantitative detection of food mycotoxins. In order to achieve a more accurate and quantitative detection of aflatoxin in food products. Zhao^[33] He used THz-TDS and metamaterial-based THz biosensors to quantify aflatoxin B1 and B2 with a frequency range of 1.0-1.5 THz. The physical properties of aflatoxin B1 and B2 were measured, by using THz-TDS (transmittance) and Maxwell-Garnett useful medium theory, including the refractive index, absorption coefficient, and dielectric function. And detect aflatoxin content, thickness and dielectric constant. Mycotoxin B2 was found to have a higher frequency shift than aflatoxin B1, which helped to distinguish between toxins. Furthermore, volumetric sensitivity to microugraded toxins was identified and detected in this technique, while also providing new methods for the detection of fungal content in food products. Hu^[34] used the essence of metamaterial structure enhancement and designed a "X" bimodal structure terHz metamaterial sensor based on electromagnetic theory, collected the THz transmission spectrum of aflatoxin B2 solution, and used stoichiometry method to model the terHz transmission spectrum of the full concentration of aflatoxin B2 solution. Realize the high sensitive, rapid and nondestructive detection of aflatoxin B2 solution.

2.4 Pesticide residues

In modern agriculture, pesticides are increasingly used to increase crop yields. However, pesticide residues can cause environmental pollution and health problems. In one study, Ma^[35] used four variable selection algorithms, partial least squares (PLS), interval PLS (iPLS), backward iPLS (biPLS) and moving window PLS (mw PLS), to predict thiabendazole content based on Terahertz time-domain spectroscopy (THz-TDS) spectrum and found that the absorption spectra from 0% to 50.21% of tibendazole were completely distinguished, and the relative error of mw PLS model from 1.06-1.22 THz, the root mean square error of cross validation (RMSECV) of 0.2392 and the root mean square error of prediction (RMSEP) of 0.3629, with high prediction accuracy. In another study, Wang and Ma^[36] used partial least

squares(PLS), interval PLS(iPLS), backward iPLS(biPLS) and moving window PLS(mw PLS) combined with 0.3-1.6 THz to assess the amount of nitrofen content. Compared with the other three models, The biPLS models were within the 0.907 – 0.943 THz, 0.962 – 0.998 THz, and 1.071-1.108 THz intervals, the root mean square error of cross validation(RMSEC_V) = 0.3157, the root mean square error of prediction(RMSEP) = 0.4064 and correlation coefficient(R) = 0.9995 predicted the best. However, PLS performed the worst, probably due to the inevitable noise brought from the entire THz spectrum. In addition, Baek^[37] explored the feasibility of detecting D-killing in wheat by Terahertz time-domain spectroscopy(THz-TDS), and selected the characteristic THz absorption peak at THz as the fingerprint for the determination of D-killing content in food matrix. The calibration curve of Dedudway shows Coefficient of Determination(R²) > 0.957, but the sensitivity of this method is still low with Level of Detail(LOD) < 3.74%. Chen^[38] implemented a THz-TDS system in the 0.3 – 1.7 THz range to quantitatively analyze imidacloprid in rice flour samples. The THz absorption coefficient lines were corrected to improve the signal to noise ratio by AsLS. Then, PLS, SVM, iPLS, and biPLS. All methods achieved satisfactory results with an average RMSEP < 0.7% and a lowest LOD of 0.99%, indicating that this method can be used for quantitative analysis of imidacloprid in rice, demonstrating the potential of THz technology for quantitative detection of pesticides. Recently, Lee^[39] reported a novel small molecule sensing tool for highly sensitive pesticide residue detection using THz-TDS of nanotrough antenna arrays and found that even 8 ppm in solution can be detected by enhanced THz spectroscopy. Furthermore, a residual concentration of 1000 ppm on the real apple skin was successfully shown by 1.0 THz reflection imaging. In terms of the penetration ability of the THz waves, the technology also provides the possibility for the real-time determination of pesticide residues in fruits, with a penetration depth of up to a few millimeters. It not only can realize the rapid nondestructive detection of pesticide content in fruit, but also its prediction accuracy is very high, which provides a new research method for the detection of pesticide residues in food. Dai^[40] proposed a metal-graphene hybrid metamaterial THz sensor designed that the metamaterial structure supports the excitation of ring dipole modes at resonance frequency. The detection limit for the solution was as low as 100 pg/mL.

Conclusion

With the rapid development of food economy, people have focused on studying the rapid and non-destructive detection methods of food safety testing. Terahertz spectroscopy technology has a unique advantage in the field of food safety. It can realize the high-resolution detection of food composition, structure and morphology, and performs well in the detection of major components such as water, fat and sugar. Terahertz spectroscopy also has the characteristics of fast, non-destructive and high sensitivity, which avoids the possible cross-contamination problems of traditional methods in the detection process, and improves the detection efficiency and accuracy. The unique advantages of THz make it stand out from both traditional and modern detection techniques. Although terahertz spectroscopy has better results, it has many limitations on water absorption, transmission depth, scattering defect, low detection limit, high signal to noise ratio, particle size and sample surface roughness compared with other traditional spectral detection. It is believed that the terahertz spectral technology will be

further improved, which will play an increasingly important role in the field of food safety testing, and make more contributions to ensuring food safety and promoting the development of the food industry.

Disclaimer (Artificial intelligence)

This article does not use generative AI technologies.

UNDER PEER REVIEW

REFERENCES

- [1] Abdelfatah Ettalibi, Abdelmajid Elouadi, Abdeljebar Mansour, AI and Computer Vision-based Real-time Quality Control: A Review of Industrial Applications[J]. *Procedia Computer Science*, Volume 231, 2024, Pages 212-220, ISSN 1877-0509, <https://doi.org/10.1016/j.procs.2023.12.195>.
<https://www.sciencedirect.com/science/article/pii/S187705092302207X>
- [2] Adebayo SE, Hashim N, Abdan K, Hanafi M (2016) Application and potential of backscattering imaging techniques in agricultural and food processing—a review [J]. *J Food Eng* 169:155–164)
<https://www.sciencedirect.com/science/article/abs/pii/S0260877415003593>
- [3] Cheng-Jin Du, Da-Wen Sun, Recent developments in the applications of image processing techniques for food quality evaluation[J]. *Trends in Food Science & Technology*, Volume 15, Issue 5, 2004, Pages 230-249, ISSN 0924-2244, <https://doi.org/10.1016/j.tifs.2003.10.006>.
<https://www.sciencedirect.com/science/article/abs/pii/S0924224403002711>
- [4] Kumar, S., Mittal, G.S. Rapid Detection of Microorganisms Using Image Processing Parameters and Neural Network[J]. *Food Bioprocess Technol* 3, 741–751 (2010).
<https://doi.org/10.1007/s11947-008-0122-6>
<https://link.springer.com/article/10.1007/s11947-008-0122-6>
- [5] Schlüter, O., Foerster, J., Geyer, M. et al. Characterization of High-Hydrostatic-Pressure Effects on Fresh Produce Using Chlorophyll Fluorescence Image Analysis[J]. *Food Bioprocess Technol* 2, 291–299 (2009). <https://doi.org/10.1007/s11947-008-0143-1>
<https://link.springer.com/article/10.1007/s11947-008-0143-1>
- [6] Singh, C.B., Choudhary, R., Jayas, D.S. et al. Wavelet Analysis of Signals in Agriculture and Food Quality Inspection. [J]. *Food Bioprocess Technol* 3, 2–12 (2010).
<https://doi.org/10.1007/s11947-008-0093-7>
<https://link.springer.com/article/10.1007/s11947-008-0093-7#citeas>
- [7] Yan Z, Zhang H, Ying Y (2007) Research progress of terahertz wave technology in quality measurement of food and agricultural products.[J]. *Guang pu xue yu Guang pu fen xi* 27(11):2228–2234)
<https://europepmc.org/article/MED/18260401>
- [8] Yan ZK, Zhang HJ, Ying YB. [Research progress of Terahertz wave technology in quality measurement of food and agricultural products]. *Guang pu xue yu Guang pu fen xi = Guang pu*. 2007 Nov;27(11):2228-2234. PMID: 18260401.
<https://europepmc.org/article/MED/18260401>
- [9] Ye Hui, Xi Mingrong, Cao Hanyu, et al. Applications of terahertz technology in medical science and research progress[J]. *Opto-Electronic Engineering*, 2018, 45(5): 170528. doi: 10.12086/oe.2018.170528.
<https://cn.oajournal.org/article/doi/10.12086/oe.2018.170528>
- [10] YANG Guang-kun, YUAN Bin, XIE Dong-yan, SHEN Xiao-dan. Analysis on the use of THz technology in the military application[J]. *LASER & INFRARED*, 2011, 41(4):376~380.
http://jgyhw.ijournals.cn/jgyhw/article/abstract/M410403?st=article_issue
- [11] Lei Hongwen, Wang Hu, Yang Xu, et al. Analysis and Prospect of the spatial application progress of terahertz technology [J]. *Space Electronics Technology*, 2017, 14 (02): 1-7 + 12.

https://kns.cnki.net/kcms2/article/abstract?v=JgtjNxUAsgcuheX2J1bki73jhl5L_yi8FNYU_Qo7LMJfZQR5Fyy9MALH4di4HaW6Huqp5mg86ug9LuiNdBN0Qx7tzBPkdRxxvAH931jhOmz0Q-EyD5PEV6HGncGO-Pi5&uniplatform=NZKPT

[12] Liu J, An J F, Zhou R, et al. Terahertz near-field MIMO-SAR technology for human security inspection[J]. *Opto-Electron Eng*, 2020, 47(5): 190682. doi: 10.12086/oe.2020.190682.
<https://cn.ojournal.org/article/doi/10.12086/oe.2020.190682>

[13] R. Cunnell et al., "Quantification of emulsified water content in oil using a terahertz quantum cascade laser," 2009 34th International Conference on Infrared, Millimeter, and Terahertz Waves, Busan, Korea (South), 2009, pp. 1-2, doi: 10.1109/ICIMW.2009.5325604.
<https://ieeexplore.ieee.org/document/5325604>

[14] Jepsen PU, Møller U, Merbold H. Investigation of aqueous alcohol and sugar solutions with reflection terahertz time-domain spectroscopy[J]. *Optics Express*. 2007, Oct;15(22):14717-14737. DOI: 10.1364/oe.15.014717. PMID:19550753
<https://europepmc.org/article/MED/19550753>

[15] A.A. Gowen, C. O' Sullivan, C.P. O' Donnell, Terahertz time domain spectroscopy and imaging: Emerging techniques for food process monitoring and quality control, *Trends in Food Science & Technology*, Volume 25, Issue 1, 2012, Pages 40-46, ISSN 0924-2244, <https://doi.org/10.1016/j.tifs.2011.12.006>.
<https://www.sciencedirect.com/science/article/abs/pii/S0924224411002937>

[16] Yuye Wang, Haibin Li, Meilan Ge, Degang Xu, Jianquan Yao. Terahertz Imaging Technology and Its Application[J]. *Laser & Optoelectronics Progress*, 2023, 60(18): 1811004.
<https://www.opticsjournal.net/Articles/OJ12cf42edd763d553/References>

[17] Liu Shenggang, Zhong Renbin. New developments in terahertz science and technology and its applications [J]. *Journal of University of Electronic Science and Technology of China*, 2009, 38(5): 481-486.
<https://www.juestc.uestc.edu.cn/article/doi/10.3969/j.issn.1001-0548.2009.05.001>

[18] Liu Xiaoqing, Yao Jiali, Huang Fan, et al. Research on penicillin drug detection based on terahertz time-domain spectroscopy [J]. *Acta Optica Sinica*, 2020, 40(6): 192-198.
<https://www.opticsjournal.net/Articles/OJf083434776ec2878/Abstract>

[19] Sirtori, C. Bridge for the terahertz gap. *Nature* 417, 132-133 (2002).
<https://doi.org/10.1038/417132b>
<https://www.nature.com/articles/417132b#citeas>

[20] Zhang Hongtao, Wang Longjie, Tan Lian, et al. Research progress of terahertz spectroscopy technology in food contamination detection[J]. *Spectroscopy and Spectral Analysis*, 2024, 44(08): 2120-2126.

https://kns.cnki.net/kcms2/article/abstract?v=5YEXIE_hGrxpNyzHM2_NqgcfnltgtYCOuURNXe9s0bIsZbsyu8QHgCCl2NtUJ7sqcV_CrtpHO4rWsJ3xDCErTWM5p8F3-MnUHM8jXvQKdbk8RYkWiR2EC51X4HYnfCKotEACfmFppAbxp5Q8nS-kkZfkq6YuS_Cf&uniplatform=NZKPT

[21] Gyeongsik Ok, Kisang Park, Hyang Sook Chun, Hyun-Joo Chang, Nari Lee, and Sung-Wook Choi, "High-performance sub-terahertz transmission imaging system for food inspection," [J] *Biomed. Opt. Express* 6, 1929-1941 (2015)
<https://opg.optica.org/boe/fulltext.cfm?uri=boe-6-5-1929&id=315811>

- [22]Hee Jun Shin, Seung Jae Oh, Min-Cheol Lim, Sung-Wook Choi, Gyeongsik Ok, Dielectric traces of food materials in the terahertz region, *Infrared Physics & Technology*, Volume 92, 2018, Pages 128-133, ISSN 1350-4495, <https://doi.org/10.1016/j.infrared.2018.05.022>.
<https://www.sciencedirect.com/science/article/abs/pii/S1350449518301440>
- [23]Yin Shen, Yanxin Yin, Bin Li, Chunjiang Zhao, Guanglin Li, Detection of impurities in wheat using terahertz spectral imaging and convolutional neural networks, *Computers and Electronics in Agriculture*, Volume 181, 2021, 105931, ISSN 0168-1699, <https://doi.org/10.1016/j.compag.2020.105931>.
<https://www.sciencedirect.com/science/article/pii/S0168169920331367>
- [24]Jun Hu, Chaohui Zhan, Hongyang Shi, Peng Qiao, Yong He, Yande Liu, Rapid non-destructive detection of foreign bodies in fish based on terahertz imaging and spectroscopy, *Infrared Physics & Technology*, Volume 131, 2023, 104448, ISSN 1350-4495, <https://doi.org/10.1016/j.infrared.2022.104448>.
<https://www.sciencedirect.com/science/article/abs/pii/S1350449522004297>
- [25]Hongyi Ge, Xiaodi Ji, Xuejing Lu, Ming Lv, Yuying Jiang, Zhiyuan Jia, Yuan Zhang, Identification of heavy metal pollutants in wheat by THz spectroscopy and deep support vector machine, *Spectrochimica Acta Part A: Molecular and Biomolecular Spectroscopy*, Volume 303, 2023, 123206, ISSN 1386-1425.
<https://www.sciencedirect.com/science/article/abs/pii/S1386142523008910>
- [26]Jianyuan Qin, Lijuan Xie, Yibin Ying, Determination of tetracycline hydrochloride by terahertz spectroscopy with PLSR model, *Food Chemistry*, Volume 170, 2015, Pages 415-422, ISSN 0308-8146, <https://doi.org/10.1016/j.foodchem.2014.08.050>.
<https://www.sciencedirect.com/science/article/abs/pii/S0308814614012655>
- [27]Jianyuan Qin, Lijuan Xie, Yibin Ying, A high-sensitivity terahertz spectroscopy technology for tetracycline hydrochloride detection using metamaterials[J] *Food Chemistry*, Volume 211, 2016, Pages 300-305, ISSN 0308-8146; <https://doi.org/10.1016/j.foodchem.2016.05.059>.
<https://www.sciencedirect.com/science/article/abs/pii/S0308814616307403>
- [28]Jianyuan Qin, Lijuan Xie, Yibin Ying, Rapid analysis of tetracycline hydrochloride solution by attenuated total reflection terahertz time-domain spectroscopy[J] *Food Chemistry*, Volume 224, 2017, Pages 262-269, ISSN 0308-8146; <https://doi.org/10.1016/j.foodchem.2016.12.064>.
<https://www.sciencedirect.com/science/article/abs/pii/S0308814616320854>
- [29]Junpeng Bai, Ying Ni, Bin Li, Haifeng Wang, Jun Zhu, Chuang Dong, Quantitative analysis of FQs antibiotics content in FMF using THz spectral and imaging technology, *Spectrochimica Acta Part A: Molecular and Biomolecular Spectroscopy*, Volume 264, 2022, 120284, <https://doi.org/10.1016/j.saa.2021.120284>.
<https://www.sciencedirect.com/science/article/abs/pii/S1386142521008611>
- [30]Lintong Zhang, Xiangzeng Kong, Linjie Chen, Wenqing Zhang, Xiyang Lin, Chuxin Wang, Yilun Jiang, Jining Li, Fangfang Qu, A multiband terahertz metamaterial sensor evaluated using a multiresponse variable fusion framework for the precise detection of trace fluoroquinolone antibiotics, *Sensors and Actuators B: Chemical*, Volume 419, 2024, 136446, ISSN 0925-4005, <https://doi.org/10.1016/j.snb.2024.136446>.
<https://www.sciencedirect.com/science/article/pii/S0925400524011766>

- [31] Hongyi Ge, Yuying Jiang, Feiyu Lian, Yuan Zhang, Shanhong Xia, Quantitative determination of aflatoxin B1 concentration in acetonitrile by chemometric methods using terahertz spectroscopy[J]. Food Chemistry, Volume 209, 2016, Pages 286-292, ISSN 0308-8146; <https://www.sciencedirect.com/science/article/abs/pii/S0308814616305982>
- [32] Liu W, Zhao P, Wu C, Liu C, Yang J, Zheng L (2019) Rapid determination of aflatoxin B1 concentration in soybean oil using terahertz spectroscopy with chemometric methods. Food Chemistry 293:213–219; <https://www.sciencedirect.com/science/article/abs/pii/S0308814619307447>
- [33] Zhao R, Zou B, Zhang G, Xu D, Yang, Y. (2020) High-sensitivity identification of aflatoxin B1 and B2 using terahertz time-domain spectroscopy and metamaterial-based terahertz biosensor[J] J Phys D Appl Phys 53(19):195401; <https://iopscience.iop.org/article/10.1088/1361-6463/ab6f90>
- [34] Jun Hu, Chaohui Zhan, Qiu Wang, Hongyang Shi, Yong He, Aiguo Ouyang, Research on highly sensitive quantitative detection of aflatoxin B2 solution based on THz metamaterial enhancement, Spectrochimica Acta Part A: Molecular and Biomolecular Spectroscopy, Volume 300, 2023, 122809, ISSN 1386-1425, <https://doi.org/10.1016/j.saa.2023.122809>. <https://www.sciencedirect.com/science/article/abs/pii/S1386142523004948>
- [35] Yehao Ma, Qiang Wang, Lanyu Li, PLS model investigation of thiabendazole based on THz spectrum[J]. Journal of Quantitative Spectroscopy and Radiative Transfer, Volume 117, 2013, Pages 7-14, ISSN 0022-4073; <https://www.sciencedirect.com/science/article/abs/pii/S0022407312005353>
- [36] Qiang Wang, Ye-hao Ma, Qualitative and quantitative identification of nitrofen in terahertz region[J] Chemometrics and Intelligent Laboratory Systems, Volume 127, 2013, Pages 43-48, ISSN 0169-7439; <https://www.sciencedirect.com/science/article/abs/pii/S0169743913001056>
- [37] Seung Hyun Baek, Heung Bin Lim, and Hyang Sook Chun, Detection of Melamine in Foods Using Terahertz Time-Domain Spectroscopy[J]. Journal of Agricultural and Food Chemistry, 2014 62 (24), 5403-5407; <https://pubs.acs.org/action/doSearch?SeriesKey=&AllField=Detection+of+Melamine+in+Foods+Using+Terahertz+Time-Domain+Spectroscopy>
- [38] Zhi-kai Chen, Ti Zhou, Ruo-yu Zhao, Hai-feng Zhang, Shu-chao Lu, Wan-shi Yang, Hong Zhou, Improved fatigue wear resistance of gray cast iron by localized laser carburizing[J] Materials Science and Engineering: A, Volume 644, 2015, Pages 1-9, ISSN 0921-5093; <https://www.sciencedirect.com/science/article/abs/pii/S0921509315301982>
- [39] Lee, KM., Herrman, T.J. Determination and Prediction of Fumonisin Contamination in Maize by Surface-Enhanced Raman Spectroscopy (SERS)[J] Food Bioprocess Technol 9, 588–603 (2016); <https://link.springer.com/article/10.1007/s11947-015-1654-1>
- [40] Zijie Dai, Maosheng Yang, Tonglin Mou, Ying Liang, Haiting Zhang, Zijun Yao, Mingyang Chen, Yunpeng Ren, Jingjing Zhang, Xiaoxian Song, Yunxia Ye, Xudong Ren, Tracing pictogram-level chlorothalonil pesticide based on terahertz metal-graphene hybrid metasensors, Optics Communications, Volume 529, 2023, 129025, ISSN 0030-4018, <https://doi.org/10.1016/j.optcom.2022.129025>. <https://www.sciencedirect.com/science/article/abs/pii/S0030401822006721>

UNDER PEER REVIEW