

# Review Article

## Research on valuation method of bill of quantities for prefabricated shear wall structure based on BIM

---

### ABSTRACT

Prefabricated shear wall structure is widely used, it can not only meet the structural performance needs of buildings, but also greatly improve the construction efficiency of buildings. It is of great theoretical and practical significance to discuss the bill of quantities valuation of prefabricated shear wall structure based on BIM for optimizing the cost control of prefabricated shear wall structure and improving the efficiency of project management. From the perspective of combining theory and practice, this paper will explore the method of bill of quantities valuation of assembled shear wall structures under BIM environment, hoping to provide a new perspective and theoretical basis for related fields.

*Keywords:* BIM; Prefabricated shear wall structure; Revit; SQL SeverDataBase.

### 1. INTRODUCTION

BuildingInformationModeling (BIM) technology as the representative of the informatization and industrialization construction, combining can not only save resources, reduce the pollution of the construction, also can realize the whole industry chain of information sharing, promote the construction of smart update<sup>[1]</sup>. Gbadamosi et al.<sup>[2]</sup> found that in the design stage of construction projects, professionals rarely consider the difficulty of construction. Zhao L et al.<sup>[3]</sup> found that with the help of BIM, workers can be matchedThe ground flow is modeled and handed over to the manufacturer to facilitate the production of prefabricated components and can also be used in the construction phase to improve project performance. GhafarMA et al.<sup>[4]</sup> found that the wide application of BIM technology will improve the economy of industrial housing by 6 points. Liu Zi-ang et al.<sup>[5]</sup> showed through case analysis that BIM has a good fit with prefabricated buildings and has good application value in cost control. Especially in the prefabricated shear wall structure, the application of BIM technology can effectively improve the design efficiency and solve the problems of repetitive design work, high cost and error, leakage and collision<sup>[6-9]</sup>.

Liu Hua et al.<sup>[10]</sup> found that the traditional construction project cost control and management methods were affected by the benefit distribution mode, which made the control and management effect poor. Zhang Dongxia et al.<sup>[11]</sup> believe that if the management effect of project cost is not ideal, it is likely to cause serious waste of resources. In terms of the valuation mode of prefabricated buildings, the traditional quota mode has been unable to sensitively reflect the changes of market supply and demand and social labor productivity, and a new pricing mode is needed to meet the needs of market competition<sup>[12-13]</sup>. AlfredA. Yee<sup>[14]</sup> compared prefabricated buildings with traditional cast-in-place buildings and confirmed that prefabricated buildings have good economic benefits through analysis of several engineering cases. BIM based bill of quantities valuation model has become the focus of research

because it can provide more accurate data of quantities and cost control. This model can not only improve the efficiency and accuracy of engineering pricing, but also automatically deal with design changes and other related problems, which is conducive to the whole process of engineering pricing and project cost management<sup>[15]</sup>.

Ren Haiyong<sup>[16]</sup> believes that there are some problems in the development of prefabricated concrete buildings at this stage, such as lack of clarity in the bill of quantities and difficulty in controlling design costs. For prefabricated shear wall structures, a BIM-based multi-level bill of quantities construction method has been proposed in previous studies, aiming to solve the problems and defects existing in the application of BIM and realize the cost management of the entire life cycle of engineering projects<sup>[17-18]</sup>. Mao Ningning et al.<sup>[19]</sup> compared the differences in project costs under different construction modes and concluded that the important reasons affecting the cost of prefabricated concrete construction are the cost of on-site installation and the cost of PC components. In addition, through comparative analysis of the influence of different prefabrication rates on the construction cost of prefabricated buildings, the research shows that there is a quantitative relationship between prefabrication rates and project costs, which provides a theoretical reference for the design of prefabricated shear wall structures<sup>[20-21]</sup>.

However, although BIM technology has significant advantages in the application of prefabricated buildings, its application in engineering pricing still faces obstacles such as contract problems, talent problems and management model problems<sup>[22-24]</sup>. Therefore, future research needs to further explore how to overcome these barriers and fully realize the potential of BIM technology in prefabricated building pricing models.

Based on the analysis of the main pricing methods of prefabricated building projects at the present stage, the in-depth analysis of the cost information demand, the BIM based on the prefabricated building quantity bill pricing method, the design of a BIM model and SQLServer database linkage method, by expanding the BIM component information and mapping, Finally, the cost of each link of the precast component is calculated in detail. The tree structure of WPF window list and model list attribute are combined to improve the information about bill of quantities. The pricing information of prefabricated components is extracted from the generated BIM model and exported to Excel prefabricated inner wall panel engineering scale, which is convenient for assembly and pricing of prefabricated engineering. It provides a comprehensive and systematic quota valuation model, which makes the valuation information of prefabricated buildings fully and accurately expressed on the basis of BIM.

## 2. BASIC PRINCIPLE

Based on BIM, the method of valuation of the bill of quantities of prefabricated buildings is mainly based on Revit software Modeling extracted the bill of quantities for budget. In the budgeting process, physical information such as component type, component characteristics and numbering, and geometric information such as length, width and height, area and volume of components are not enough. For price calculation, There is still a need for some expanded information about the quantity of works and the information about the quota in the external module, the price library of the manpower machine and so on source price base and rule base information. On this basis, expand the information of the cost, such as the specific description of the construction process the description of the project characteristics and so on, and then according to the "prefabricated construction project consumption quota" summary, thus generated corresponding quota database. Then modify the measurement rules of the bill of quantities to form the measurement rules with BIM The underlying database is consistent<sup>[25]</sup>. The result is a BIM-based prefabricated building pricing information.

Related SQL Server database, through BIM model and quota database and external resource price the library is linked to obtain the corresponding costs and form a detailed budget table. Figure 1 shows the main process.

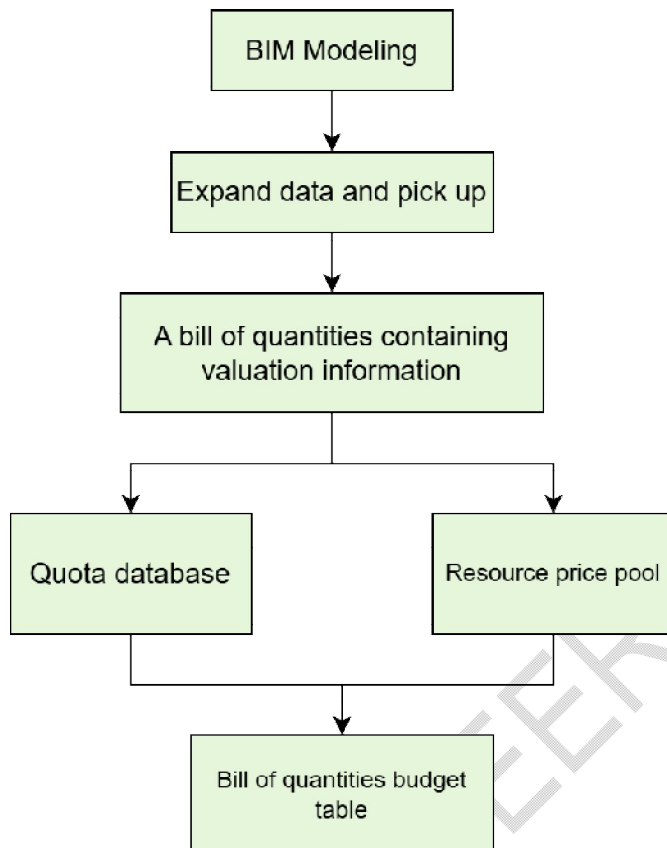

**Figure 1. Create flow chart based on BIM model quota database**

In this paper, the prefabricated component is taken as the basic unit, and the unit price composition in the bill of quantities of prefabricated concrete construction is calculated in the form of comprehensive unit price. The direct engineering cost, management fee and profit of each component are included in the PC component, and the labor cost, material cost and mechanical cost of the direct engineering cost are calculated by the corresponding consumption and the corresponding price, and are added and summarized, and the management fee can be obtained through the historical project data.

$$\text{Labor cost} = \sum \text{daily wage} \times \text{daily consumption} \quad (1)$$

$$\text{Material cost} = \sum \text{unit price of each material} \times \text{quantity of materials} \quad (2)$$

$$\text{Machinery cost} = \sum \text{unit price of mechanical shift} \times \text{consumption of construction machinery shift} \quad (3)$$

The profit is calculated according to the corresponding ratio. Measures, fees and taxes are listed separately. Because the construction technology of prefabricated building is a new technology, there are some problems in the measurement standard, such as the lack of measure project cost, the lack of basis for pricing, and the blindness of price group. There-

fore, the information in this part mainly comes from the market, and the market provides the corresponding information<sup>[26]</sup>.

### **3. EXTERNAL MODULE EXTENSION**

#### **3.1 BIM parametric model engineering quantity statistics**

Since Revit software already has a built-in specification export function, we can filter the attributes of model artifacts for export according to the required information. The measurement rules of different components are quite different, but at present, parameterized information model is used as the carrier, and through Revit secondary development programming, suitable components are selected according to the changes of engineering quantity calculation rules, so as to calculate the corresponding engineering quantity. Ensure that no calculation errors will be caused by inconsistent measurement rules during project implementation.

According to the "prefabricated building Engineering Consumption Quota" (TY01-01(01)-2016), the calculation rule of the concrete structure engineering quantity is calculated according to the actual volume of the finished component design diagram size, and the unit of measurement is cubic meter ( $m^3$ ). In Revit software, the concrete volume has been listed in the property bar of the model component, so in the process of extracting the engineering quantity, we only need to obtain the property of the component, and we can directly know the volume of the prefabricated component. However, it should be noted that the unit of measurement in the quota is 10 cubic meters ( $10m^3$ ), while the volume unit in the software is cubic meters ( $m^3$ ). Therefore, we need to carry out unit conversion to get the actual amount of concrete works, to ensure that in the process of project implementation, there will be no calculation errors due to inconsistent measurement rules.

#### **3.2 Quota calculation data write**

When assigning quota information to components, components such as columns, beams, panels, walls in the Prefabricated Building Works Consumption Quota, as well as the quota items of these components in the installation process, shall adopt the relevant quota sub-headings in the document. At the same time, it is mentioned in the general instructions that the quota should be used as a supplement to the consumption quota of housing construction and decoration engineering, and the two can be used together. Therefore, for the module parts not involved in the "prefabricated building engineering Consumption quota", the relevant quota items in the "Building construction and decoration engineering consumption quota" are calculated accordingly.

The collected consumption quota is sorted out and written into the SQLServer database table so that it can be invoked in Revit software. The quota information stored in the database can be easily managed and obtained to meet different calculation and analysis needs.

The durability of rubber recycled concrete refers to its long-term stability and durability under different environmental conditions. Researchers can conduct various experiments on the durability of rubber recycled concrete, including freeze-thaw resistance, sulfate corrosion resistance, chloride ion penetration resistance, etc. These experiments can be conducted by simulating exposure tests under different environmental conditions.

In SQLServer, creating tables is a key step in building a database, which is the foundation of data storage and management. The first task is to determine the purpose of the table and

analyze the information it should contain. This step involves identifying the columns of requirements. Start with the columns that determine the purpose and requirements of the table, further refine the data types and attributes of each column, and then select the appropriate key fields to ensure that SQLServer data types correspond to the relevant C# entity class attribute types, as shown in Table 1, when SQLServer data types and C# entity class attribute types are inconsistent, This can cause data to deform or lose precision as it passes between the application and the database. Correct mapping between data types can avoid data conversion errors at runtime, and ensure correct mapping between data types can maintain data consistency and avoid incorrect conversion between types. This logical and coherent process determines the basic operation of creating tables in SQLServer, ensuring effective, accurate, and efficient data storage and management.

**Table 1. SQLServer data types correspond to the associated C# entity class attribute types**

Entity class attribute type	Database data type
string	char,nchar,varchar,nvarchar
int	int,smallint,bigint
DateTime	datetime,smalldatetime
float	float
bool	byte
decimal	decimal,money

When these data need to be used, just through Revit software to connect to SQLServer, query the corresponding table can extract the information we need. Using the database to store data is easy to update and maintain the data, ensuring that the information is always up-to-date and meets the needs of the actual project cost. In this way, the consumption of prefabricated components can be calculated conveniently and efficiently, improving work efficiency, reducing errors, and providing more accurate cost estimates. Figure 2 shows the writing result on the inner wall panel.

The screenshot shows the SQL Server Management Studio interface with a query result table. The table has the following columns: Number, project n..., measurin..., classificati..., designati..., quota co..., and unit. The data rows are as follows:

Number	project n...	measurin...	classificati...	designati...	quota co...	unit
1-8	NQ	10m3	RG	ZGR	10.198	day
1-8	NQ	10m3	Material	concrete	10.050	m3
1-8	NQ	10m3	Material	iron	9.990	kg
1-8	NQ	10m3	Material	mortar	0.090	m3
1-8	NQ	10m3	Material	HDP	52.976	m
1-8	NQ	10m3	Material	crosser	0.010	m3
1-8	NQ	10m3	Material	sidestay	0.377	set
1-8	NQ	10m3	Material	ironwork	7.448	kg
1-8	NQ	10m3	Material	iroplate	3.640	kg
1-8	NQ	10m3	Material	QMF	0.600	%
1-8	NQ	10m3	Mechanical	blender	0.009	shift
*	NULL	NULL	NULL	NULL	NULL	NULL

**Figure 2. Internal wall panel quota consumption data table**

### 3.3 Reading and application of quota calculation data

RevitAPI programming interface and SQLServer database are used as important tools for data processing. The combination of RevitAPI and SQLServer allows us to efficiently process a large number of data while ensuring the accuracy of the data, and when necessary, it can easily increase, delete and modify the operation of these data, which provides strong support for the intelligent management of prefabricated construction projects.

The API functions provided by RevitAPI can execute SQL query statements to read the data in the SQLServer table, so as to obtain the required fixed consumption information, and store these information in a data structure after processing according to predetermined rules.

In order to improve the usability and user experience of the program, a more intuitive and interactive interface was developed using WPF (Windows Presentation Foundation) technology. After obtaining the data, by designing the WPF user interaction window, using Revit API and SQL Server database connection, the data is effectively bound in WPF and displayed on the user interface, and a visual operation interface is provided to import the prefabricated building quota consumption into the window interface, so that the data in the quota can be easily viewed and used. It provides the data basis for calculating the quota. Part of the code is as follows. Figure 3 shows the process.

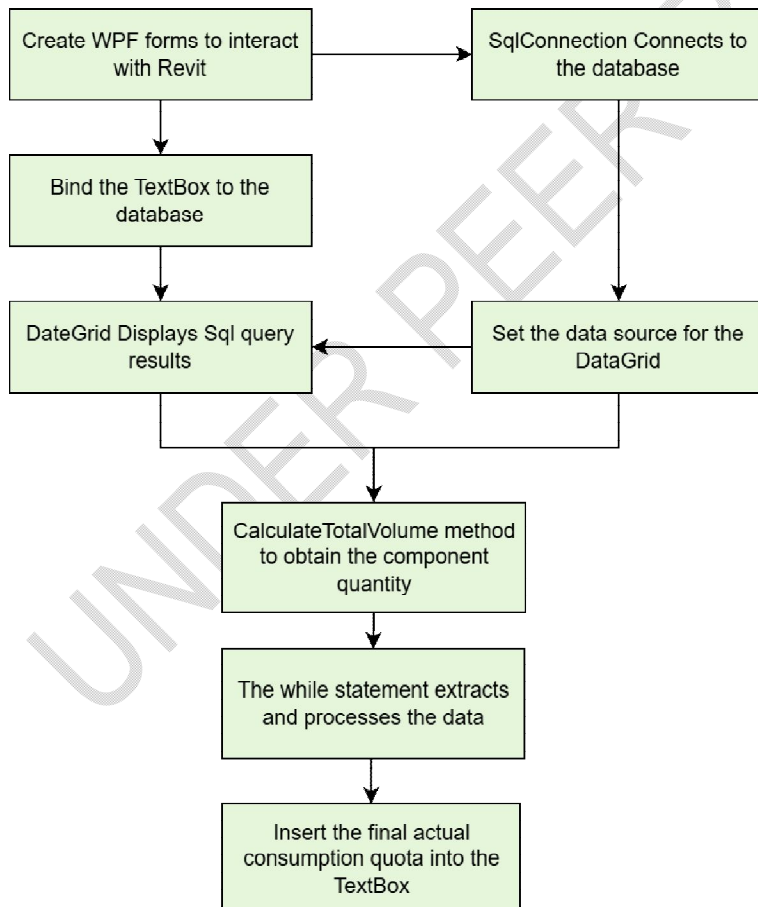
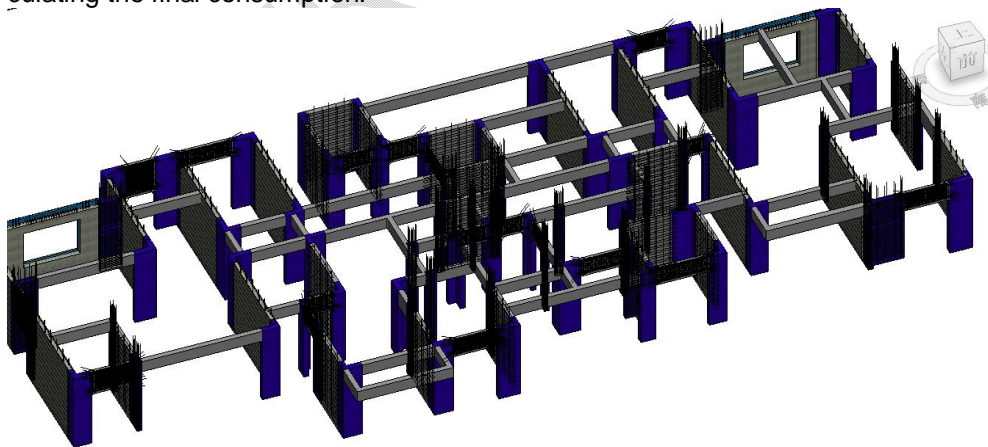

Figure 3. The consumption quota program creates an idea chart

In the calculation of engineering quantity, components are selected. Taking the inner wall panel as an example, the model components to be collected are selected by PickObjects method according to the existing parametric model, and the selected components are stored in the List collection to prepare for subsequent processing and reference. Then the collector is used to obtain the concrete model, judge the engineering quantity of the component, and add the engineering quantity of the component whose engineering quantity is not zero. The unit of measurement between the actual engineering quantity and the unit of the quota consumption is converted. Finally, external events are started through the implementation of the IExternalEventHandler interface, and the calculation parameter totalVolume of the engineering quantity is transferred to the interface of WPF user interaction.

In quota calculation, you can create a WPF DataGrid control to display the relevant data. Create a temporary virtual table (DataTable) to store the data and associate the values entered by the user in the TextBox with the SQL query Parameters, using the parameters.AddWithValue method. This method belongs to the SqlParameterCollection class in the System.Data.SqlClient namespace and is used to add parameters to the parameter set of the SqlCommand object to avoid SQL injection attacks and to process dynamic values when executing SQL queries or stored procedures. Based on the query results in the consumption quota database, the resulting data is bound to the ItemsSource data source of the DataGrid control and displayed in the DataGrid control. After reading the associated return values of the fixed consumption from the SQLServer database, create a custom collection columnData to store the read data. A while loop is used to read data from the collection columnData, row by row, and multiply the data in each column with the total volume of work obtained by the external event. Finally, the results of the calculation are written and displayed in the TextBox control of WPF through a loop.

In the WPF interface, the engineering quantity and consumption quota are set as independent parts respectively. When the user selects the component project name, the system automatically maps the corresponding quota number. By selecting the component to be calculated, the corresponding engineering quantity and actual consumption quota can be calculated immediately. In the valuation analysis, users can directly reference and refer to these consumption quota information to improve work efficiency and accuracy. Figure 4(a) is used as an example for calculating the final consumption. Figure 4(b) shows the interface for calculating the final consumption.



(a)

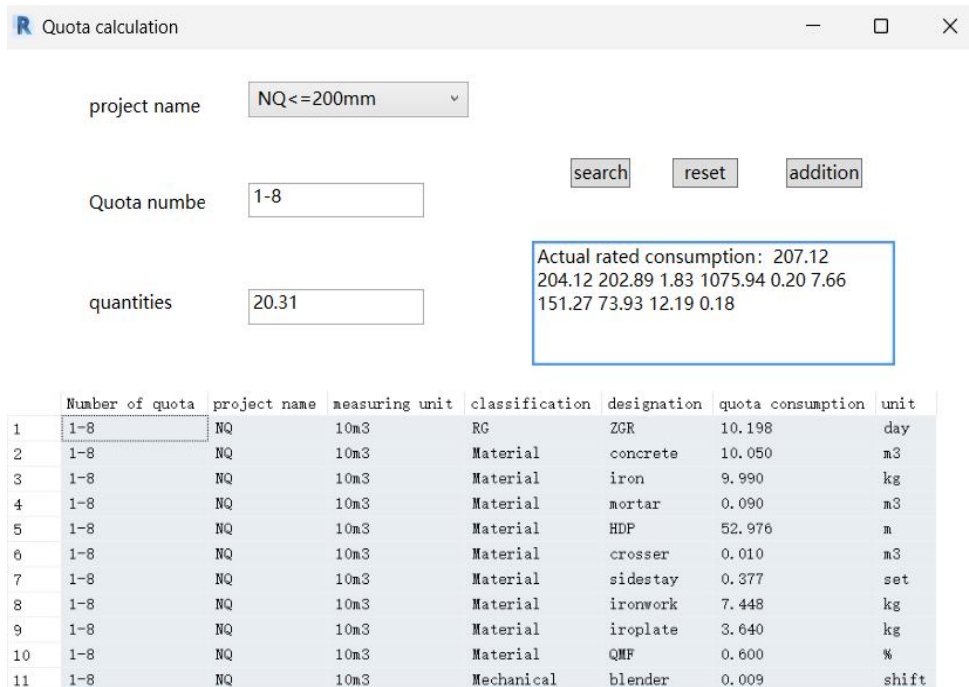

(b)  
**Figure 4. Calculation of actual norm consumption of standard layer. (a) Revit model, (b) WPF calculation results.**

## 4. APPLICATION OF BILL OF QUANTITIES VALUATION MODE

### 4.1 BILL OF QUANTITIES DESIGN

The bill of quantities adopts the form of tree structure, which is a typical hierarchical structure. In the calculation of engineering quantity, we can set the relevant engineering quantity and cost data on each node of the tree, so that we can obtain the corresponding total amount and total cost of the project by statistics and summary of the sub-nodes of each node. The tree list makes it easy for us to group by category, count the relevant engineering quantity, and understand the construction information of each part or each job, including specific data such as demand and engineering quantity.

In the WPF framework, the TreeView control has an obvious hierarchical feature, and its structure is very similar to the file directory display we usually see. The TreeView uses the TreeViewItem object to represent each node. Each TreeViewItem object has the ability to play the role of a parent node and has one or more child TreeViewItem nodes.

In the bill of Works architecture, we can map each individual engineering task or project as a TreeViewItem node, which is related to each other to build a clear parent-child hierarchy. This structure consists of basic elements (elements), detailed attributes (attributes) and descriptive Text (Text), the starting core node is called the parent node, each node can have its own child nodes. Through systematic rules and methods, we can easily traverse these nodes and extract the attribute information carried by each node. Its structured presentation is shown in the figure 5. The data model can adopt the custom method Tree(intparentid,Listnodes), bind node information to ItemsSource data source in a recursive

way, and dynamically generate WPF tree structure, thus forming a complete tree task system. Using the TreeView, we can also easily add, remove, or change node information.

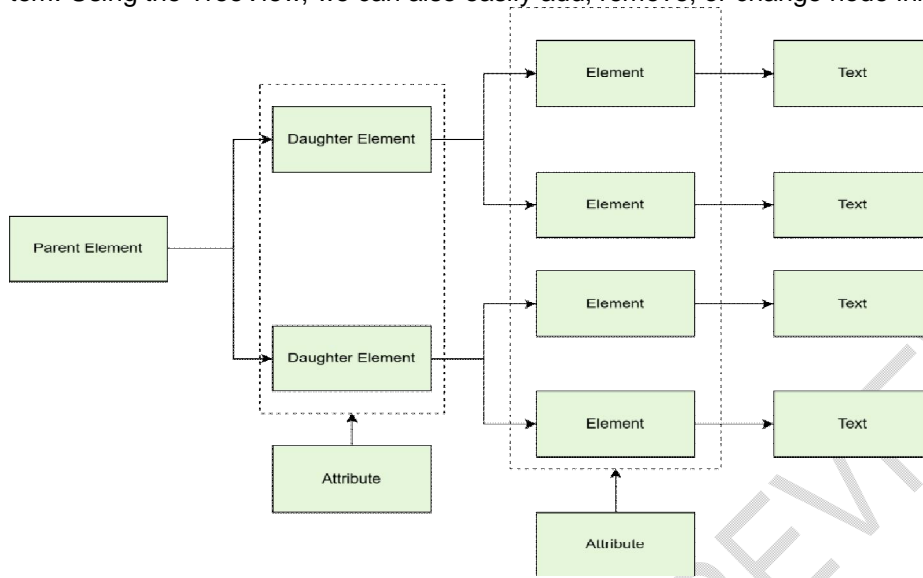

Figure 5. TreeView element structure

Add 3D view to WPF program, display the model, and select the components in the list to further improve the parameters of the model list. The WPF control operation effect is shown in the figure 6.

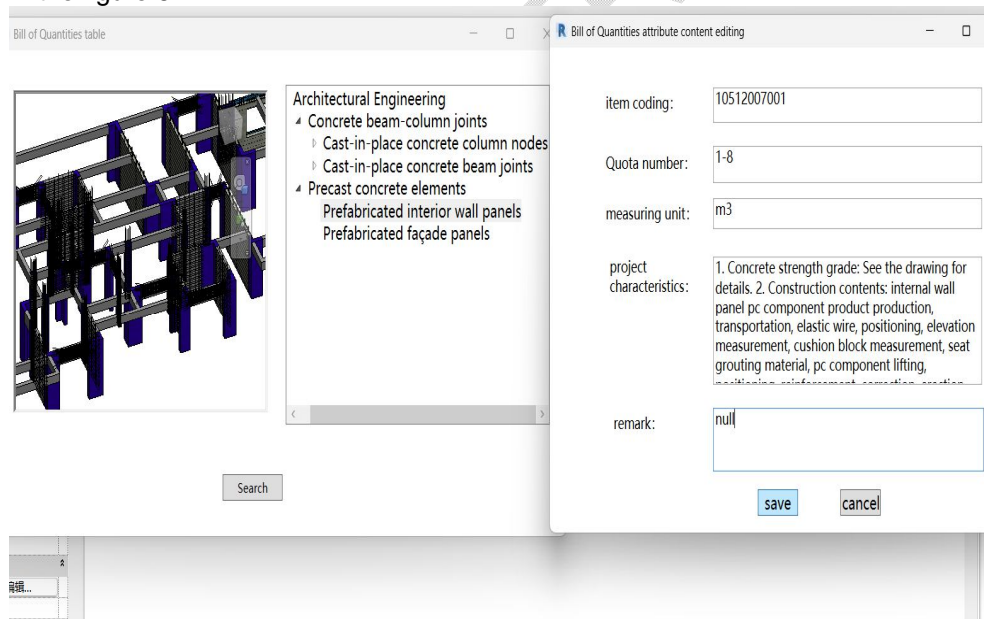

Figure 6. WPF Bill of Quantities content properties Edit final renderings

#### 4.2 Bill of quantities exported

Revit provides users with a statistical tool called "detail table", which can realize the statistical function of the number of components and related parameters for users. By reviewing the RevitAPI documentation, you can use ViewSchedule to create statistics for rebar count

schedules. CreateSchedule () function. This function takes two parameters: the Revit document and the type of Id needed to create the detail table.

Methods to mobilize ViewSchedule. CreateSchedule run Revit, create a list for prefabricated type. Using the schedule. Definition. GetSchedulableFields () obtain all schedulable fields, according to the field names need to be screen is added in the list need to describe the field (such as "member type", "volume", "project", etc.), And use the schedule. Definition. Add-Field method will be added to the list of these fields. Check whether the field is a built-in parameter, and if so, create a sort group field for the field and add the sort group field to the specification table. Figure 7 shows the engineering quantity list of prefabricated inner wall panels.

Detailed list of precast interior wall panels													
Number	Item coding	Classification	Measuring unit	Project characteristics	Quota number	Total	Volume	Thickness	Direct construction cost				man
									RGF	MF	GXF	Total prices	
1	10512007001	NQ-3628	m <sup>3</sup>	1. Concrete strength grade: See the drawing for details. 2. Construction contents: internal wall panel pc component product production, transportation, elastic wire, positioning, elevation measurement, cushion block measurement, seat grouting material, pc component lifting, positioning, reinforcement, correction, erection and removal of steel supports, sleeves and other information	1-8	10	20.31 m <sup>3</sup>	200mm	2843.4	13140.57	4082.31	20066.28	
2	10512007001	NQ-3028	m <sup>3</sup>	1. Concrete strength grade: See the drawing for details. 2. Construction contents: internal wall panel pc component product production, transportation, elastic wire, positioning, elevation measurement, cushion block measurement, seat grouting material, pc component lifting, positioning, reinforcement, correction, erection and removal of steel supports, sleeves and other information	1-8	3	5.08 m <sup>3</sup>	200mm	711.2	3286.76	1021.08	5019.04	
4	10512007001	NQ-1828	m <sup>3</sup>	1. Concrete strength grade: See the drawing for details. 2. Construction contents: internal wall panel pc component product production, transportation, elastic wire, positioning, elevation measurement, cushion block measurement, seat grouting material, pc component lifting, positioning, reinforcement, correction, erection and removal of steel supports, sleeves and other information	1-8	16	16.13 m <sup>3</sup>	200mm	2258.2	10436.11	3242.13	15936.44	
			Total: 30				42.70 m <sup>3</sup>		5812.8	27626.9	8582.7	42187.6	

Figure 7. Bill of quantities for precast interior wall panels

#### 4. CONCLUSION

Based on BIM technology and related theoretical research of prefabricated consumption quota valuation, this paper makes a deep discussion on the valuation process of prefabricated engineering. The whole process is managed and operated by digital means, and a complete, consistent and easy to update assembly type consumption quota database is created by writing the quota consumption in SQLSever database. The database is read and written in real time using the Revit program API development interface, and the quota consumption information is connected with the BIM model of the current project. Based on the existing parametric model, the automatic calculation of the engineering quantity of prefabricated components is realized. According to the calculated engineering quantity data and the quota consumption information in the database, the valuation work of the assembled engineering quantity list is completed. The effective combination of BIM technology and prefabricated consumption quota valuation theory has brought more accurate budget and more effective resource management to construction projects, and also promoted the further promotion and application of prefabricated building technology in the construction field.

Combined with WPF technology, the program operation interface is developed to increase the operability of the program. The content of bill of quantities is stored in the form of tree structure, the attribute content of model list is perfected, and the quantity of prefabricated

components is automatically derived from the three-dimensional model of prefabricated building, and the forward design program from the three-dimensional model to the two-dimensional bill of quantities is completed. This study provides a reference for the subsequent research on automatic forward design of prefabricated building engineering.

## REFERENCES

1. Han, X. Research on collaborative valuation model of prefabricated buildings based on BIM DB model. Master's Thesis, Dongbei University of Finance and Economics, Dalian, 2019.
2. Gbadamosi, A.Q.; A. Mahamadu; P. Manu.; O. Akinade.; F. Sierra.; T. T. Lam.; A. Alzaatreh. A BIM based approach for optimization of construction and assembly through material selection. In Proceedings of the Creative Construction Conference. 2018.
3. Zhao, L.; Liu, Z.; Mbachu, J. Optimization of the Supplier Selection Process in Prefabrication Using BIM. *Buildings* 2019, 9, 222.
4. Ghafar, M.A.; Ibrahim, R.; Shari, Z. Embedding Cultural Knowledge in Building Information Modeling (BIM) for Fabrication Efficiency to Reduce Industrialized Construction Waste. In International Conference on Computing in Civil and Building Engineering. 2014, 195-202.
5. Liu, Z.A.; Guo, G.J. Research on cost control of prefabricated building construction based on BIM. *Construction economy* 2022, 43, 40-46.
6. Wang, F.P.; Wu, T.; Liu, X. Research on prefabricated shear wall structure based on BIM technology. *Construction techniques* 2019, 48, 16-19+83.
7. Yang, J. Research on the parametric design of shear wall structure based on BIM. Master's Thesis, Shenyang University of Technology, Shenyang, 2016.
8. Lin, M.S. Research on the detailed design of prefabricated shear wall components based on BIM. Master's Thesis, Shenyang University of Technology, Shenyang, 2019.
9. Li, S.Y. Research on deepening design method of prefabricated shear wall structure based on Tekla. Master's Thesis, North China University of Water Resources and Electric Power, Zhengzhou, 2023.
10. Liu, H.; Zhao, M.X. Research on construction cost control and management based on BIM technology. *Modern electronic technology* 2021, 44, 163-166.
11. Zhang, D.X. Analysis of the cost management strategy of prefabricated building under the mode of inventory valuation. *ceramics* 2023, 02, 173-175.
12. Zhang, X.N.; Guo, G.J.; Lou, N. Research on dynamic valuation method of prefabricated buildings based on BIM components. *Engineering management journal* 2022, 36, 147-152.
13. Tan, K.B. Research on construction pricing data structure and pricing model based on BIM. Master's Thesis, Beijing Jiaotong University, Beijing, 2016.
14. Alfred, A.Y. Structural and economic benefits of precast/prestressed concrete construction. *PCI Journal* 2001, 07, 34-42.
15. Liu, C. Research on construction of multi-level bill of quantities for building projects based on BIM. Master's Thesis, Beijing Jiaotong University, Beijing, 2017.
16. Ren, H.Y. A brief discussion on the cost management of prefabricated buildings by using bill of quantities valuation mode. *Construction technology* 2016, Z1, 136-138.
17. Zhang, X.R.; Guo, J.J. Research on Construction of bill of quantities for prefabricated construction based on BIM. *Journal of Engineering Management* 2021, 35, 30-35.
18. Xie, J.; Jiang, D.F.; Zhou, P. Study on Prefabrication rate and cost of prefabricated shear wall structure System. *Building Structure* 2018, 48, 33-36.
19. Mao, N.N. Cost analysis and control countermeasures of prefabricated concrete construction. Master's Thesis, Fujian University of Technology, Fuzhou, 2018.

20. Gu, S.B. Research on construction technology and economy of prefabricated shear Wall Structure. Master's Thesis, Southeast University, Nanjing, 2019.
  21. Li, F.; Zhou, C.G.; Zheng, Z.P. Technical and Economic Analysis of Assembled Monolithic frame-Cast-in-place Shear Wall Structure. *Building Structure* 2016, 46, 107-111.
  22. Zang, A.Q. Research on the Application of Inventory Valuation Model in the cost management of prefabricated buildings. *Journal of Chifeng University (Natural Science Edition)* 2017, 33, 123-125.
  23. Wang, Y.Y.; Ren, H. Research on valuation control of bill of Quantities based on component. *Construction Economics* 2013, 363, 34-37.
  24. Chen, B. Research on Cost management of prefabricated buildings based on Bill of Quantities valuation model. Master's Thesis, Southwest Petroleum University, Chongqing, 2019.
  25. Zhang, X.R. Research on the valuation mode of prefabricated concrete construction quantity bill based on BIM. Master's Thesis, Beijing Jiaotong University, Beijing, 2019.
- Sun, L.Z.; Xv, S.; Wang, Y.N. Research on Cost Management of prefabricated buildings under inventory pricing model. *Construction economy* 2017, 38, 29-32.

UNDER PEER REVIEW