

Integrating Automation and Big Data in Lithium-Ion Battery Manufacturing: A case Study of the Ultium Cells Joint Venture

ABSTRACT

Aim: To examine the integration of automation and big data in lithium-ion battery manufacturing using Ultium Cells joint venture as case study.

Problem Statement: The havocs attached to the exhausts emission from fossil-fuel based automobiles are major concerns to the whole world. Records indicating lowering of air quality and depletion of the ozone layer have been reported.

Significance of Study: The use of electric vehicles is prevailing and thus has greatly influenced the need to technological improvement in the production of lithium-ion batteries (LIBs) which are being utilized in electric vehicles. This technical review is an eye-opener for researchers on the need to integrate automation and big data in lithium-ion battery manufacturing.

Methodology: Recent literature materials in form of books, journals and relevant published articles in the area of automation and big data in lithium-ion battery manufacturing were consulted.

Discussion: In this technical review, consideration was given to the integration of automation and big data in lithium-ion battery manufacturing using Ultium Cells joint venture as a case study. The types of lithium-ion batteries and their assemblies were discussed. The battery cells contain the cathode, anode and electrolyte and come in three varieties of designs which are pouches, prismatic cans and cylindrical designs. One of the main requirements that enhance the automation of assembly line in Li-ion battery manufacturing is the use of the collected data from the survey as stated by the industry. The concept is made up of 6 modular sectors such that each sector has the capacity of being scaled up and down based on customer requirements. The three major steps involved in data-driven application to lithium-ion battery cell manufacturing are data acquisition, data warehouse and data mining.

Conclusion: The integration of automation and big data in lithium-ion battery manufacturing has positively influenced the quality and quantity of the products.

Keywords: Automation, Data-driven, Lithium-ion battery, Electric vehicle, Ultium Cells Joint Venture

1. INTRODUCTION

Battery manufacturing industry has been named as one of the fastest-growing industries around the world owing by the need for energy storage and conservation for consumption purposes. Not only this, the quest to save money spent on non-renewable energy has also been a major contributory factor [1]. Additionally, the need to protect the environment and

Commented [Ma1]: Highlight what author want to find out. Try to reflect the objective, for eg: to identify the challenge related to the integrating automation and big data.....

Commented [Ma2]: The result shall be clearly stated in the conclusion.

atmosphere from the release of poisonous gases from combustion engines into the atmosphere causing global warming of the ozone layer has also influenced the growth of battery manufacturing industries. By year 2025, the European government is aspiring to ban the use of vehicles powered by Internal Combustion Engine (ICE). This is mounting pressure on Original Equipment Manufacturers (OEM) in order to replace the conventional ICE vehicles with alternative fuel. The invention of Electric Vehicles as a new evolution has positioned rechargeable Lithium-ion (Li-ion) powered vehicles excellently in global market. Between 2018 and 2025, the sale of these invented vehicles is expected to increase to 12 million from 2 million amounting to 500% increment in sale. The major problems associated with EVs presently are the range of discharge and price per unit for vehicles. There is need to address these two main issues for Li-ion battery manufacturers to encourage future buyers. Roughly 30% of the total cost of EV is placed for the EV battery packs out of which manufacturing takes 40% of the power unit cost. Electrode manufacturing, cell assembly and cell finishing are the three main sequential Lithium-Ion battery manufacturing stages. Of all the varieties of batteries as products from battery manufacturing industry, lithium-ion batteries (LIBs) have been identified as excellent devices for the storage of rechargeable energy due to its convenient characteristics which are: high energy density, long life cycle and little or no memory effects. All these have resulted into its speedy expansion in various fields of applications [2].

Lithium ion batteries (LIB) are those battery types that have long life cycle, high specific energy and efficiency. They comprise a cathode and an anode having a dielectric medium purposely for the transportation of ions between the existing elements. LIB technology has been developing very rapidly, with OEMs aspiring to increase battery range with utmost assurance of stabilizing the chemistry. Rapid development has been observed in Solid-State Batteries (SSBs) and Li-air with the expectation that the former will become an established form of battery [3]. SSBs have the ability for the provision of higher energy capacities while maintaining the safety simultaneously as a result of the solid electrolyte which are expected to be generally utilized in the next decade. The expectation of such technological advancement may be playing a significant role in postponing further investment into new manufacturing capacity of already existing Li-ion production specifically in Europe. Figure 1 represents types of lithium-ion batteries and their assemblies.

Commented [Ma3]: More readable if this part is moved to the literature review in Section 2.0

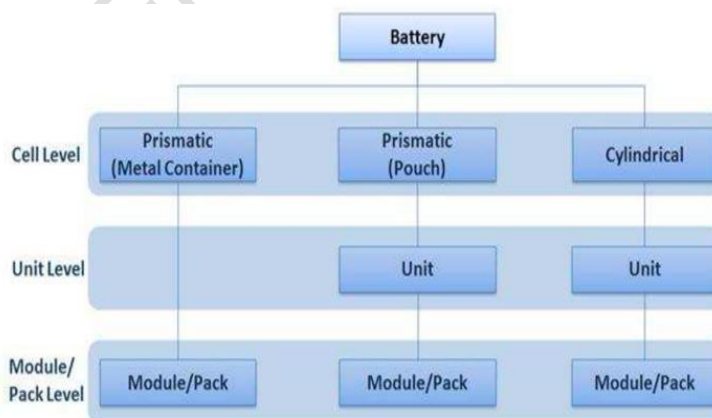

Figure 1: Types of lithium-ion batteries and their assemblies

Li-ion batteries possess similar structure and are made up of cells combined together to make a module, which are in turn, combined together to make a pack. The battery cells contain the cathode, anode and electrolyte and come in three varieties of designs which are pouches, prismatic cans and cylindrical designs [4]. The cells are then welded together after stacked to form modules which can consist of individual thermal management systems used in controlling cell temperature within the module. Ultrasonic welding is adopted in joining the modules which are then sent for assembling into the overall battery pack which is the top level of the Li-ion bill of materials. The pack comprises multiple modules merged together with mechanical fixings to enable easier disassembly for servicing benefits. The pack equally comprises of a battery management system that controls the thermal management system for each of the modules. Li-ion battery packs are multifaceted systems. In addition to the materials needed for the cathode, anode and electrolyte, they also need battery management systems, cooling systems, sensors, central module contractor systems, insulation packages and housing for both the entire battery pack itself and individual modules. Figure 2 represents the automotive battery assembly packs [5].

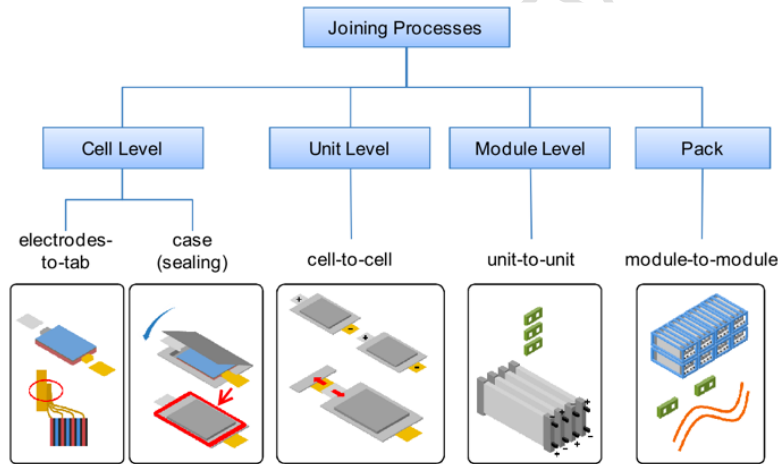

Figure 2: Automotive battery assembly packs

The multifaceted benefits of LIBs have called for the need to improve their energy density at the cell level [6]. It is established that equally-sized LIB pack with high energy density LIB cells will result into extra power to increase their outputs. Thus, either of the following should be noted to achieve higher energy density in LIBs cell level: (1) designing LIB cells through selecting adequate materials alongside the modification and combination of those materials using various cell engineering approaches which is a materials-based design technique or (2) optimizing cell design parameters using a parameter-based design technique. LIB behaviors change at different cell design parameters. Low lithium ion diffusivity, low electrolyte conductivity, poor kinetics of charge transfer increased solid electrolyte interface (SEI) resistance are the major influencing factors causing capacity diminish, power weakening and charge exertion in LIBs. The Li ions low diffusivity results in intercalation rate reduction causing lithium plating at the graphite surface during charging process. When

lithium ions deposited change into dead lithium, LIB capacity fading comes into play [7]. This is also as a result of non-participation of deposited charge in the later electrode reaction. Nonetheless, the grown dendrites enter into the separator membrane causing internal short circuit which is a fearful safety problem. Also, overheat is another environmental factor that affects LIB performance under different temperature. The reactions that occur in a LIB as a result of increase in temperature are stated thus: (1) reaction between the binder and the anode-active materials, (2) reactions between the electrolyte and the anode-/cathode-active materials, (3) electrolyte decomposition and (4) SEI decomposition.

When the pressure is at high level, the cell may burst causing poison gas and electrolyte solvents leakages. When the generated heat is more than the dissipated heat during overheating process, the temperature of the cell speedily rises due to the exothermic process occurrence [8]. The increase in temperature further contributes to the rise in the chemical reactions rather than the planned galvanic reactions. This generates more heat volume and eventually results in the use of thermal coolants like liquid, hydrogel, air and phase change materials in the battery thermal management systems. The optimization of the coolants heat capacity and heat transfer rate greatly verifies the advancement of battery thermal management systems. There is need to optimize the thermal management structure so as to remove the hot spot suffering over temperature which is also a highly efficient and dependable solution. With the aforementioned challenges attributed with the manufacturing, environmental influences and output performance of LIBs, there is need to Integrate automation and big data into the manufacturing processes [9].

Lithium-ion battery cells production is attributed with high complexity level with diverging and converging material flows, single unit and batch processes together with discontinuous and continuous processes. Using advanced approaches, the cell final quality can only be evaluated after it has gone through all production steps. Thus, production management techniques aiming at zero-defect production, scrap reduction and identification of components at the earliest during production process chain are essential. A high transparency level in relation to data would be useful [10]. An appropriate data management and data acquisition implementation would enable the effective utilization of data mining together with modelling and simulation approaches so as to increase production operation and planning. As a consequence of the process chain complexity and length, a huge data volume can be generated in the battery cells production.

A case study is the Ultium Cells which is a joint venture between General Motors and LG Energy Solution. Total of 3 plants in Ohio, Tennessee and Michigan are built or under construction. Currently, the Ohio facility is under full operation, so the case study will focus on it. The first plant in Ohio is a \$2.3 billion plant with 2.8 million-square-foot footprint. It started initial production in August, 2022. The annual battery cell output is 40 GigaWatt-hours under full production, which is equivalent to approximately 400,000 cars. Recently, Ultium Cells in Tennessee has announced that the company will be investing an extra \$275 million in order to expand the facility's battery cell output by greater than 40 percent from 35 GWh to 50 GWh after the plant is fully operational. This new investment is in addition to the existing \$2.3 billion investment which was announced in April 2021. Battery cell production at the 2.8 million-square-foot facility was placed to begin in late 2023 [11]. The third plant in Michigan is under construction and production equipment ramp-up.

Commented [Ma4]: Purpose and advantage of the study shall be stated here.

2.0 AUTOMATED ASSEMBLY LINE IN THE MANUFACTURE OF LITHIUM-ION BATTERY: ULTIUM CELLS CASE STUDY

Ultium Cells is 2.8 million-square-foot battery manufacturing plant with annual capacity of 40GWh, which is equivalent to 400,000 EVs. In order to fully operate the facility, incoming raw material, in-house semi-product, and outgoing finished product must move continuously to the right place at the right time. In Ultium Cells, the logistics system is fully automated by using combination of Automated Guided Vehicle (AGV), Conveyor and Stacker Crane. Manufacturing Execution System (MES) allows to create and execute moving commands based on designed routes. The automated system also monitors the current location of each product in case of command failure or process delays. Moreover, control room displays all logistics information and provides real-time 3D map to assist process control. [12]

The Northern Ohio facility was the result of joint venture between tier 1 OEM battery manufacturer and an American auto maker having the largest plants for lithium-ion battery manufacturing in the USA. This facility is exceptional among the several existing ones in the USA which primarily produce electric vehicles (EVs) batteries. Multiple processes involving the fabrication of the raw materials into finished cells in the manufacturing facility. The major areas of consideration for Li-ion Tamer are approximately close to the completion of the production process because the cells have already taken their last form factor, precisely in the charge/discharge processes and jig formation. The SEI (solid electrolyte interphase) layer of the cells is developed during the jig formation process which helps in critical functions like cell lifetime, safety, performance and stability. The charge/discharge process is incorporated in the further cells cycling to improve the performance. There exist two areas for each of the process having five lines per unit area for a total of ten charge/discharge lines and jig formation [12].

2.1 Electrode

The automated logistics system begins with incoming raw materials. Raw materials arrive in bulk, and they are put into Mixer via conveyor system. After mixing at intended viscosity and tortuosity, they move through sophisticated pipelines to be coated onto copper or aluminum bare foil [13]. As batteries become larger for higher capacity and performance, the foils have also become larger. Hence, the coated foils, called Electrode Roll, now weighs more than hundreds of kilograms. As Electrode Roll is too heavy and dangerous to be carried by an operator, an AGV delivers and stores them in stacker crane. When the next process, Cell Assembly, is in need of the semi-product, stacker crane feeds them right away. Fully automated delivery system assures both efficiency and safety [14]. Figure 3(a) is the the electrode fabrication process stage-wise optimization strategy while Figure 3(b) is the illustration of the mixing sequence 1 and sequence 2 for preparing the electrode slurries [15]

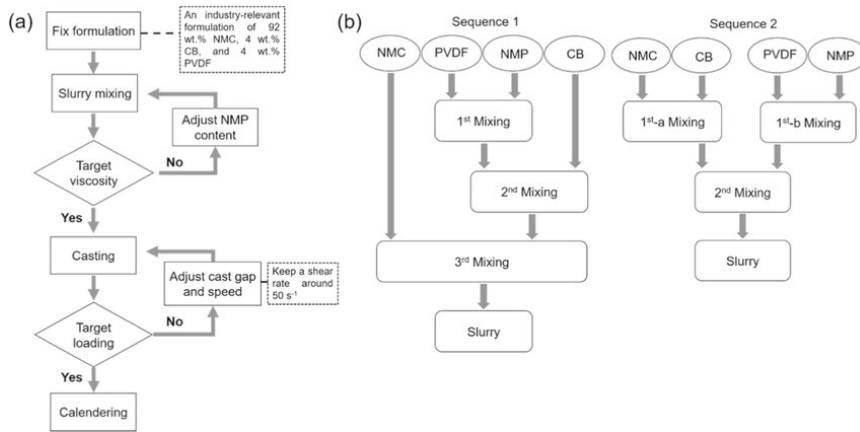

Figure 3: (a) The electrode fabrication process stage-wise optimization strategy. (b) Illustration of the mixing sequence 1 and sequence 2 for preparing the electrode slurries [15]

Commented [Ma5]: Make this figure more clear

2.2 Cell Assembly

In Cell Assembly, Anode/Cathode Electrode Roll and Separator Roll are cut into individual pieces and stacked together to form a battery. Then, the stacked unit is sealed in a canister, which Ultium Cells uses aluminum pouch. The sealed battery cell, as an individual unit, is smaller and manageable by an operator, so conveyor system dominates in Cell Assembly. In order to protect and safely deliver battery cells, a container, called Tray, is used. The Tray is delicately designed to protect weak spots and minimize vibration. The automated system seeks an efficient route to provide semi-product where needed. It sometimes has to seek an alternative route due to machine breakdown, maintenance or inspection. The system becomes even more complicated when producing multiple models to prevent different models from being mixed [16]. Figure 4 is the schematic of the IoT conveyor system and its operation process [17].

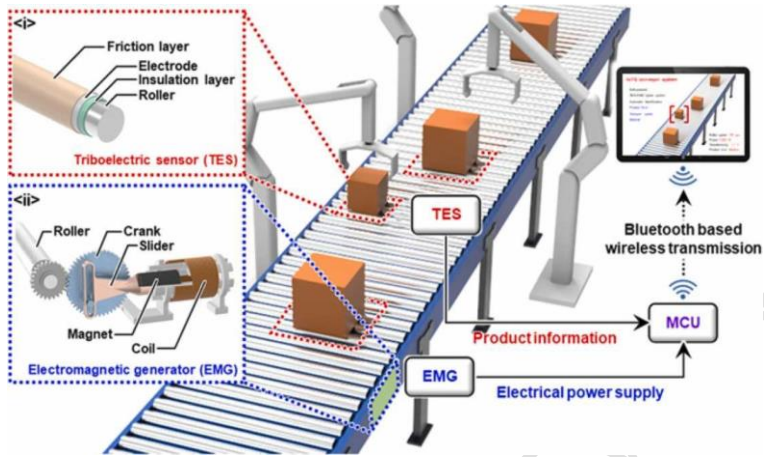

Figure 4: Schematic of the IoT conveyor system and its operation process [17]

2.3 Cell Finishing

Cell Finishing process requires the most extensive area in Lithium-ion battery manufacturing. Therefore, there are multiple factors to cause the logistics system more complicated than the other processes. Cell Finishing consists of sophisticated process steps, which may take weeks to finish the entire process. In addition, semi-product in Cell Finishing often has to be sent to certain area to select defects and travel back and forth to repeat certain steps. As the system becomes more complicated, more logistics data are generated, and managing the data requires adequate database [16]. To control all processes as intended, accurate and efficient route design is critical. Similar to Cell Assembly, the dominant automated system in Cell Finishing is conveyor and stacker crane. However, process delays or losing commands still may occur due to the complexity of logistics system. Hence, it is necessary to install logistics monitoring system and provide warnings to assist operators [17]. Figure 5 is a single-mast stacker crane [18].

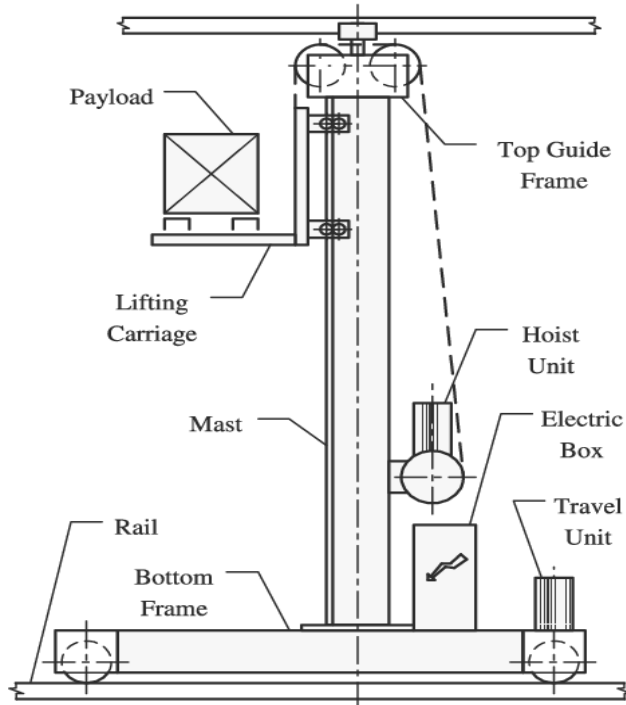

Figure 5: Single-mast stacker crane [18]

2.4 Shipping

After Cell Finishing, the good cells are palletized. These pallets weigh more than hundreds of kilograms, so combination of AGV, conveyor and stacker crane are used. An AGV delivers the pallets and stores them in stacker crane until shipping is scheduled. If shipping is scheduled, the pallets are taken out of stacker crane and moved to the dock for transportation [19]. It is relatively straightforward and simple, however, safety is a priority in Shipping because the final product is charged and may cause thermal event.

2.5 Control Room

Ultium Cells has adopted 3D monitoring system. It shows the current machine status for all AGV, Conveyor, or Stacker Crane system from Electrode to Shipping. It also assists operators by providing the current location of each product. In addition, the 3D monitoring system is able to provide warnings to analyze inefficient moving commands, bottleneck of movement or process delays. This system implemented in Control Room. A supervisor can easily monitor the system and provide direction to the floor for operators to act in advance [20]. Figure 6 represents the assembly modeling via Anylogic.

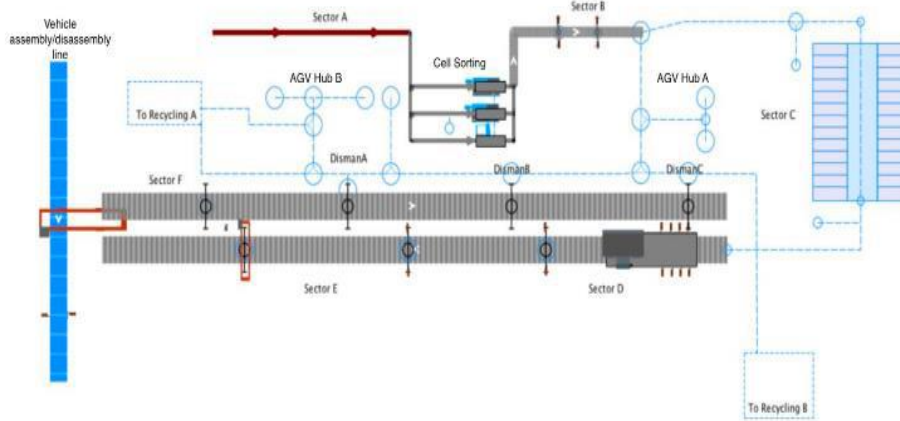

Figure 6: Assembly modeling via Anylogic.

3.0 DATA-DRIVEN APPLICATION TO LITHIUM-ION BATTERY CELL MANUFACTURING

The three major steps involved in data-driven application to lithium-ion battery cell manufacturing are data acquisition, data warehouse and data mining. The developed technique is linked with the pilot scale lithium-ion battery cell manufacturing of Ultium Cells Joint Venture which covers extremely flexible production line that gives room for both small-scale production and research [21].

3.1 Data Acquisition

It is important to adequately understand relevant and significant data connecting the process, final product and intermediate products. Figure 8 shows the existing relation between intermediate product, process and final product of lithium-ion battery cells production [9]. This shows how material is utilized in a process for the creation of an intermediate product leading after n production procedures to a final product which is the battery cell. The production step results towards the finished battery cell are the processed materials which are the intermediate products. Certain process parameters such as conveyor belt speed, sealing temperature and rotational speed are utilized in setting up the production machines along the production chain. These process factors are functions of the state variables such as temperature and pressure which are measured during the process. State variables (SV) and process parameters (PP) affect the intermediate product characteristics such as structure (e.g. porosity, particle size distribution, thickness of coating layer and so on) and properties (e.g. electric conductivity, viscosity, tortuosity and so on). These intermediate product characteristics determine the battery cell final product properties such as internal resistance, maximal capacity, self-discharge and so on. These explain the performance and quality of the battery cells [11-12].

Process/machine data explains all significant process data, both state variables and adjustable process parameters of the processes, excluding state variables, ambient condition, process parameters and so on. The information regarding the mechanism of

operation of the production machines is presented in this data which can be accessed via the production machine panel computer or the programmable logic controller. All energy demands required for technical building services and production processes are covered by the energy demands data. The technical building service data comprises the ambient condition for special production conditions such as humidity and temperature and production processes [22-24]. The intermediate product analytics explains the intermediate products which include slurry, electrode sheets, electrode coils and so on with the aid of off-line or in-line analytical methods to evaluate the structure (layer thickness, porosity, particle size distribution and so on) or their properties (such as electric conductivity, tortuosity and so on). Final product analytics handles the battery cell analytics and diagnostics on an electrochemical scale (C-rate, capacity, electrochemical impedance spectroscopy, etc.). This data assists in assessing the final product quality. All the relevant data required for production campaigns execution and planning (material amount, production times and so on) are described by the operational data [25]. This data is of high significance because it gives the required knowledge needed in allocating all other relevant data to the production campaigns. Figure 7 indicates complex system of lithium-ion battery cells production using data-driven approach while Figure 8 is the complex system of lithium-ion battery cells production using data-driven approach.

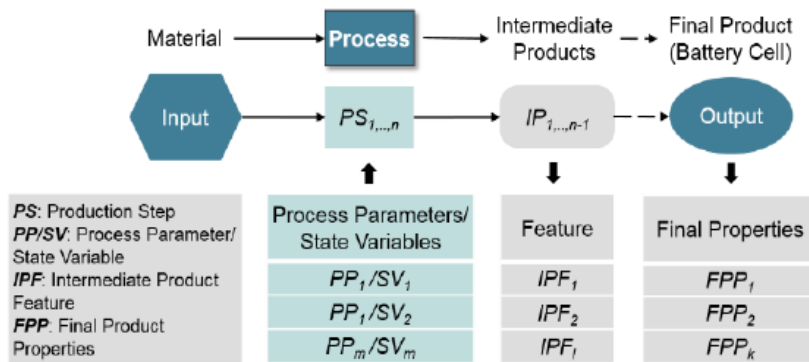

Figure 7: Relation between intermediate product, process and final product in production of lithium-ion battery cells

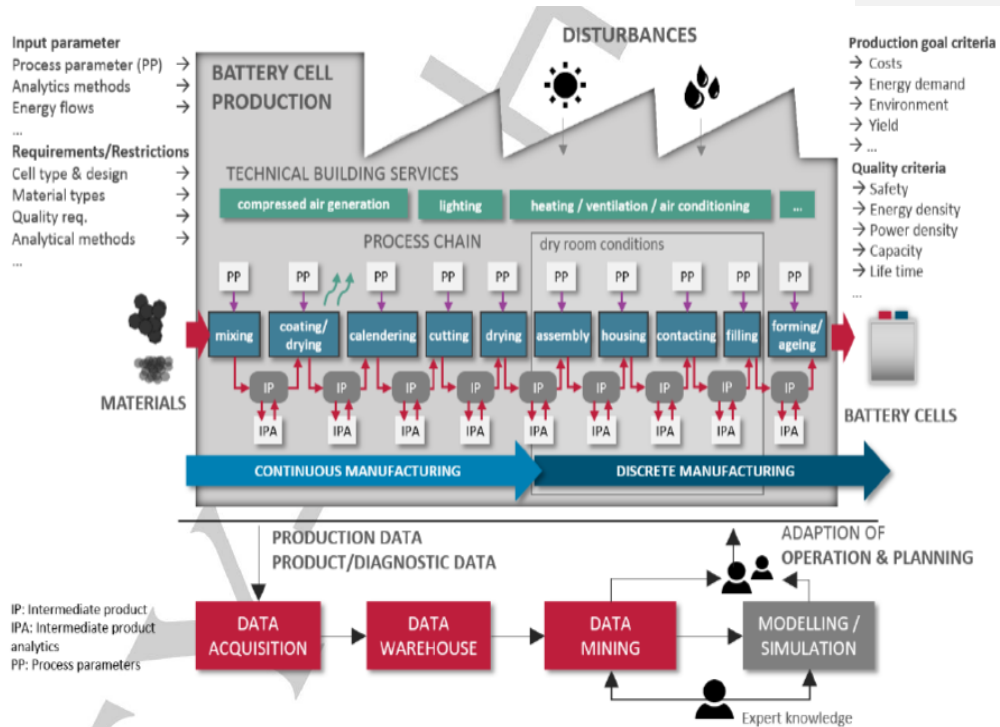

Figure 8: Complex system of lithium-ion battery cells production using data-driven approach

3.2 Data Warehouse

All the data from the two various acquisition techniques is obtained by the data warehouse to enable the preprocessing and allocation (that is tracing and tracking) of the automatically acquired data to the manually acquired data. This data is then reserved for further purposes. In order to use machine learning or other data analytical methods to obtain knowledge from the data, data mining can access the reserved data. The main purpose of the data warehouse is to merge, gather and store the data in such a way that it can be accessed for future usage. Extraction, transformation and loading of the data first took place at the data warehouse where the related data is merged after allocation. After this, the data storage is executed in relational tables comprising structured query language (SQL) database called "first layer" in the data warehouse concept [23-26]. Preprocessing of the data in the "first layer" occurs so as to get the easily accessible information via the application of statistical methods such as evaluation of standard deviation, mean values, median and so on. Key figures are estimated so as to access many of the information within the corresponding data sets in the further data processing. After this stage, the not processed data and the extracted information are stored in denormalized tables. They are called the "second layer" of the SQL database in the data warehouse concept.

Commented [Ma6]: Provide more information on data characteristics and sources.

3.3 Data Mining

The application of statistical methods to large data sets in order to uncover trends and correlations is called data mining. Computer-based methods are used to automatically process these data sets because they are too numerous to be manually processed. Data mining originates from "mining" in a larger volume of data for knowledge, causalities or understanding within it. Formerly it has been stated as the data analytics procedure within the process: "knowledge discovery in databases". Data mining has since then become a more liberated wording and has many definitions and different procedural views based on its process [27]. Cross Industry Standard Process for Data Mining is among the most significant process definitions utilized and the most analogous to the definition to knowledge discovery in databases. This process is not firmly straightforward and comprises iterative steps and feedback loops to ascertain that all knowledge and understanding gotten within the process can be utilized to increase the used algorithm power. The six procedural steps include: understanding the business, understanding the data, preparation of data, modelling, evaluation and deployment [28].

Commented [Ma7]: This section can be left off. Too general knowledge.

3.4 Data Analysis

Development of camera and image processing method has allowed broader application to manufacturing. It is more accurate, consistent, and faster than human eyes. Ultium Cells applied vision system extensively to different processes across the plant. The vision system is integrated with quality criteria to reject dimension and cosmetic defects. During such inspection, dimension data and cosmetic images are created every day [23]. Production engineers have access to all these data, which are analyzed to prevent process deviation. Furthermore, implementing interdependencies with previous processes allows the system to easily identify the source of defects. The image data is also useful for quality engineers to confirm the risk range.

3.5 Integration with AI

Integrating with Artificial Intelligence (AI) will develop automation and big data even further. Automation and big data still rely on data engineers' analytics, and an incorrect interpretation may lead to wrong decisions. AI implementation to the manufacturing system allows production to be more predictive. For instance, AI can predict machine failures by analyzing machine data, minimizing production loss. Another advantage of applying AI, especially to Lithium-ion battery manufacturing, is that it can predict battery performance. Current technology is limited to predict battery performance from material changes, so engineers are dependent on test and sampling statistics. Ultimately, AI-driven automation will design and optimize production process on its own analytic decision [27-29]. Figure 9 is the algorithm for data-driven application in lithium-ion battery cell manufacturing.

Commented [Ma8]: It will more interesting if the author explains how AI is embedded in the process.

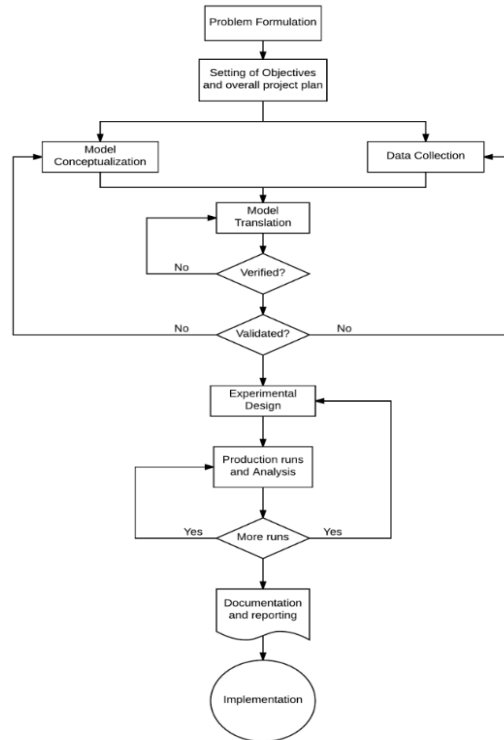

Figure 9: Algorithm for data-driven application in lithium-ion battery cell manufacturing

4. CONCLUSION

The havocs attached to the exhausts emission from fossil-fuel based automobiles are major concerns to the whole world. Records indicating lowering of air quality and depletion of the ozone layer have been reported. Thus, the use of electric vehicles is prevailing and thus has greatly influenced the need to technological improvement in the production of lithium-ion batteries (LIBs) which are being utilized in electric vehicles. In this technical review, consideration was given to the integration of automation and big data in lithium-ion battery manufacturing using Ultium Cells joint venture as a case study. The types of lithium-ion batteries and their assemblies were discussed. It was stated that Li-ion batteries possess similar structure and are made up of cells combined together to make a module, which are in turn, combined together to make a pack. The battery cells contain the cathode, anode and electrolyte and come in three varieties of designs which are pouches, prismatic cans and cylindrical designs. One of the main requirements that enhance the automation of assembly line in Li-ion battery manufacturing is the use of the collected data from the survey as stated by the industry. The concept is made up of 6 modular sectors such that each sector has the capacity of being scaled up and down based on customer requirements. The three major steps involved in data-driven application to lithium-ion battery cell manufacturing are data acquisition, data warehouse and data mining. In conclusion, the integration of integration of

Commented [Ma9]: Clearly stated on the benefit and application of this study

automation and big data in lithium-ion battery manufacturing has positively influenced the quality and quantity of the products.

REFERENCES

1. Lee JY, Lee YM, Bhattacharya B. Separator grafted with siloxane by electron beam irradiation for lithium secondary batteries. *Electrochim. Acta*, 2021, 54, 4312–4315.
2. Jiang FJ, Yin L, Yu, QC. Bacterial cellulose nanofibrous membrane as thermal stable separator for lithium-ion batteries. *J. Power Sources*, 2023, 279, 21–27.
3. Chun, S.J., Choi, E.S., Lee, E.H. Eco-friendly cellulose nanofiber paper-derived separator membranes featuring tunable nanoporous network channels for lithium-ion batteries. *J. Mater. Chem.*, 2019, 22, 16618.
4. Ferrari S., Quartarone, E., Mustarelli, P. A binary ionic liquid system composed of N-methoxyethyl-N-methylpyrrolidinium bis(trifluoromethanesulfonyl)-imide and lithium bis(trifluoromethanesulfonyl)imide: a new promising electrolyte for lithium batteries. *J. Power Sources*, 2022, 194, 45–50.
5. Wen, J.W., Yu, Y., Chen, C.H.: A review on lithium-ion batteries safety issues: existing problems and possible solutions. *Mater. Express*, 2023, 2, 197–212.
6. Islam, M. S., Ahsan, M. S., Rahman, M. K., & AminTanvir, F.. Advancements in Battery Technology for Electric Vehicles: A Comprehensive Analysis of Recent Developments. *Global Mainstream Journal of Innovation, Engineering & Emerging Technology*, 2023, 2(02), 01-28.
7. Schomburg F, Heidrich B, Wennemar S, Drees R, Roth T, Kurat M, Heimes H, Jossen A, Winter H, Cheong JY, Roeder F. Lithium-ion battery cell formation: status and future directions towards a knowledge-based process design. *Energy Environ. Sci.*, 2024, 17, 2686.
8. Chung, Y.S., Yoo, S.H., Kim, C.K.: Enhancement of meltdown temperature of the polyethylene lithium-ion battery separator via surface coating with polymers having high thermal resistance. *Ind. Eng. Chem. Res.*, 2018, 48, 4346–4351.
9. Sharma, N., Peterson, V.K.: Overcharging a lithium-ion battery: effect on the LixC6 negative electrode determined by in situ neutron diffraction. *J. Power Sources*, 2019, 244, 695–701.
10. Kim, G.H., Pesaran, A., Spotnitz, R. A three-dimensional thermal abuse model for lithium-ion cells. *J. Power Sources*, 2023, 170, 476–489.
11. Cao, H., Xia, B.J., Xu, N.X., et al.: Structural and electrochemical characteristics of Co and Al co-doped lithium nickelate cathode materials for lithium-ion batteries. *J. Alloy. Compd.*, 2024, 376, 282–286.
12. Ultium Battery Manufacturing Plant, Ultium Battery Factory Case Study Report, May 2023. Li-ion Tamer, 1-3.

13. Kondrakov, A.O., Schmidt, A., Xu, J., et al.: Anisotropic lattice strain and mechanical degradation of high- and low-nickel NCM cathode materials for Li-ion batteries. *J. Phys. Chem. C*, 2023, 121, 3286–3294.
14. Godwin O, Jen A. Control Strategies for Battery Chargers: Optimizing Charging Efficiency and Battery Performance, 2024.
15. Wang M, Dang D, Meyer A, Arsenault R, Cheng Y. Effects of the mixing sequence on making lithium ion battery electrodes. *J. Electrochem. Soc.*, 2020, 167 100518.
16. Elia G.A., Ulissi U., Jeong, S. Exceptional long-life performance of lithium-ion batteries using ionic liquid-based electrolytes. *Energy Environ. Sci.*, 2022, 9, 3210–3220.
17. Ra Y, Kim J, Kim H, Cho S, Lee D, Jang S, Kam D, La M, Park SJ, Choi D. Smart conveyor roller system for self-powered product size identification in electrically off-grid condition via hybridization of triboelectric-electromagnetic generators. *Nano Energy*, 2022, 100, 107447.
18. Hajdu S, Gáspár P. Reducing the mast vibration of single-mast stacker cranes by gain-scheduled control. *International Journal of Applied Mathematics and Computer Science*. 2016, 26, 4, 37-48.
19. Chandrasekaran R., Koh, M., Ozhawa, Y. Electrochemical cell studies on fluorinated natural graphite in propylene carbonate electrolyte with difluoromethyl acetate (MFA) additive for low temperature lithium battery application. *J. Chem. Sci.*, 2019, 121, 339–346.
20. Abraham, D.P., Roth, E.P., Kostecki, R., et al.: Diagnostic examination of thermally abused high-power lithium-ion cells. *J. Power Sources*, 2021, 161, 648–657.
21. Mingguo, O., Ren, D.S., Lu, L.G. Overcharge-induced capacity fading analysis for large format lithium-ion batteries with $\text{Li}_y\text{Ni}_{1/3}\text{Co}_{1/3}\text{Mn}_{1/3}\text{O}_2 + \text{Li}_y\text{Mn}_2\text{O}_4$ composite cathode. *J. Power Sources*, 2022, 279, 626–635.
22. Islam MS, Ahsan MS, Rahman M. K., & AminTanvir, F. (2023). Advancements in Battery Technology for Electric Vehicles: A Comprehensive Analysis of Recent Developments. *Global Mainstream Journal of Innovation, Engineering & Emerging Technology*, 2(02), 01-28.
23. Cao, G.Z.: Solvent-salt synergy offers a safe pathway towards next generation high voltage Li-ion batteries. *Sci. China Mater.*, 2020, 61, 1360–1362.
24. Li, J.C., Ma, C., Chi, M.F. Solid electrolyte: the key for high-voltage lithium batteries. *Adv. Energy Mater.*, 2022, 5, 1401408.
25. Ahsan, M. S., Tanvir, F. A., Rahman, M. K., Ahmed, M., & Islam, M. S. Integration of Electric Vehicles (EVs) with Electrical Grid and Impact on Smart Charging. *International Journal of Multidisciplinary Sciences and Arts*, 2023, 2(2), 225-234.
26. Yuan, Q.F., Zhao, F.G., Wang, W.D. Overcharge failure investigation of lithium-ion batteries. *Electrochim. Acta*, 2015, 178, 682–688.
27. Zhang, S.S., Xu, K., Jow, T.R.: Electrochemical impedance study on the low temperature of Li-ion batteries. *Electrochim. Acta*, 2024, 49, 1057–1061.

28. Wang, H.Y., Tang, A.D., Huang, K.L.: Oxygen evolution in overcharged $\text{Li}_x\text{Ni}_{1/3}\text{Co}_{1/3}\text{Mn}_{1/3}\text{O}_2$ electrode and its thermal analysis kinetics. *Chin. J. Chem.*, 2022, 29, 1583–1588.

29. Rastgoo-Deylami, M., Javanbakht, M., Omidvar, H.: Enhanced performance of layered $\text{Li}_{1.2}\text{Mn}_{0.54}\text{Ni}_{0.13}\text{Co}_{0.13}\text{O}_2$ cathode material in Li-ion batteries using nanoscale surface coating with fluorine-doped anatase TiO_2 . *Solid State Ionics*, 2019, 331, 74–88.

UNDER PEER REVIEW