

Original Research Article

Empowering Vegetable Farmers: Energy Analysis and Evaluating the Impact of a Battery-Operated Boom Sprayer

ABSTRACT:

India heavily relies on agriculture, with a majority of the population engaged in farming. To address labor scarcity and improve efficiency, a battery-operated boom sprayer was developed and evaluated. In testing on a brinjal crop field, the sprayer achieved a theoretical field capacity of 0.36 ha/hr and an actual field capacity of 0.284 ha/hr, with a field efficiency of 79%. Compared to manual knapsack sprayers, it demonstrated favorable ergonomic performance. These findings highlight the sprayer's potential to enhance efficiency, cost-effectiveness, and ergonomics for small Indian farmers, addressing labor scarcity and improving their livelihoods. Further testing and considerations for widespread adoption are necessary. This innovation represents a significant step towards sustainable development in Indian agriculture.

Keywords: Battery operated boom sprayer, theoretical field capacity, and ergonomic performance

1. INTRODUCTION:

Farming is the backbone of the Indian economy, with various field operations and spraying being crucial for crop protection (Kumar et al., 2020; Gupta et al., 2018). Over the past 50 years, the agricultural sector has evolved, emphasizing disease control (Dey et al., 2019). Plant protection equipment plays a significant role in maximizing crop productivity (Singh et al., 2017). Agricultural pests, including fungi, bacteria, viruses, insects, mites, nematodes, weeds, and grain-eating birds, pose challenges to crop cultivation (Wolman and Fournier, 1987). Effective plant protection strategies are essential for minimizing losses and optimizing agricultural inputs (Ghosh et al., 2021).

Chemical application in pest control requires specialized equipment for effective and mechanized farming operations. Knapsack sprayers, ultra-low volume sprayers, and tractor boom sprayers are among the machinery developed for this purpose (Liu, 2008).

Weed causes a substantial loss of food grains in India, estimated at 40 million tons per year (Singh and Sahay, 2001). Different spraying methods are used, including manual, engine-operated, and tractor-operated sprayers. While power sprayers have been developed, they can be costly for farmers. Manual sprayers, operated by hand, result in operator fatigue and decreased capacity and efficiency.

The study aimed to develop a battery-operated boom sprayer for vegetable crops, evaluate its performance, and assess its cost economics. The equipment utilized a DC motor driven by a 12 V, 26 Ah battery, with adjustable power through hand accelerators. A sprocket arrangement connected the motor to the ground wheel's main shaft, which transferred revolution. The ground wheel had a sprocket connected to a chain drive, operating a slider crank mechanism. This mechanism converted rotary motion into reciprocating motion, driving a single-acting reciprocating pump. The pump drew pesticide during the upward motion of the connecting rod and forced it through the delivery valve during the downward motion. The delivery valve was connected to a pipe with multiple nozzles acting as outlets for the pesticides.

2. MATERIAL AND METHODS:

2.1 Specification of developed battery operated ground wheel boom sprayer.

The developed battery-operated ground wheel boom sprayer features a robust frame made of M.S. rectangular pipe ($50 \times 30 \text{ mm}^2$) that securely holds various components, including the knapsack sprayer, sprocket, scotch yoke mechanism, motor, battery, sprayer boom pipe, and chain. The frame's dimensions are $520 \text{ mm} \times 720 \text{ mm}$, providing stability and support. The sprayer is operated using a 30 mm diameter square MS pipe handle ($25 \text{ mm} \times 25 \text{ mm}$) attached to the main frame. The handle, with a length of 900 mm, allows for easy maneuverability and is adjustable in height (520 mm to 1080 mm) for operator comfort. This well-designed sprayer ensures durability and facilitates efficient agricultural spraying tasks (Gite and Yadav, 2007). The labelled conceptual design of developed machine is shown in Fig. 1.

1. Handle
2. Ground wheel
3. Battery
1. Handle
2. Ground wheel
3. Battery
4. Main frame
5. Pesticides tank
6. Boom
7. Boom stand
8. Boom pipe
9. Nozzle
10. Big sprocket
11. DC motor
12. Chain
13. Small sprocket

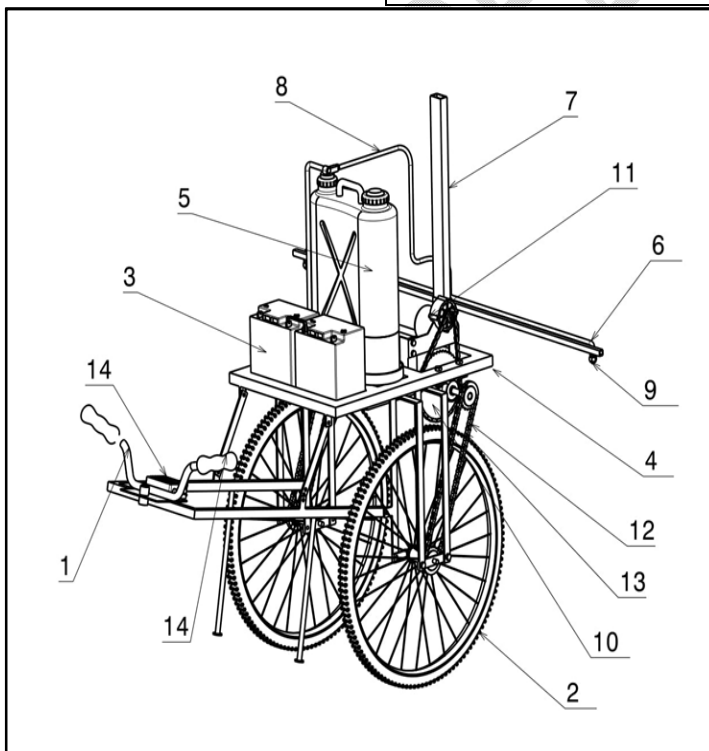

Fig.1 Schematic diagram of developed **battery-operated** boom sprayer

2.2 Laboratory evaluation of developed battery operated boom sprayer

2.2.1 Measurement and Analysis of Discharge Rate

The discharge rate from each nozzle was measured within 0.5 m intervals of 1.5 m to assess variation. During each 0.50 m interval, the discharge from each nozzle was collected using a bag and measured with a measuring cylinder (Fig. 2). The time taken to cover each interval was recorded to calculate the discharge rate. Each interval was replicated three times. To analyze the variation of discharge rate among the nozzles within each 0.50 m interval, the coefficient of variation (CV %) was utilized.



Fig.2 Discharge rate test

2.2.2 Uniformity of spray pattern test

The uniformity of coverage in spraying operations is determined by the type of nozzle, nozzle spacing, boom height, and spray angle. To achieve the most uniform coverage, a wide-angle single hole brass hollow cone nozzle is recommended, with the boom height set at the minimum recommended level. Adjusting the boom height can result in over- or under-application, especially with narrow spray angle nozzles, which are more sensitive to changes in boom height. Therefore, careful consideration of these factors is essential for ensuring consistent and uniform spray coverage.

2.2.3 Spray angle and swath width

During a laboratory test, the nozzle was positioned at various heights from the ground level, and liquid was sprayed. The width of the spray was observed to estimate the spray angle for both the single hole and five-hole brass hollow cone nozzles.

2.3 Field test

In a field trial on a 0.28 ha Brinjal field, nozzle discharge was measured to evaluate the amount and variation of discharge rates within a 30 m distance. Plastic bags were tied to each nozzle to collect the discharge, which was then measured using a cylinder. Three replications ensured discharge uniformity, analyzed by the coefficient of variation. The total liquid sprayed, time taken, and measurements enabled calculation of application rate, field capacity, and efficiency of the sprayer.

2.3.1 Field testing area

The developed machine was tested for brinjal crops in a field with dimensions of 70×40 m. The field contained 55 rows with a row-to-row spacing of 0.7 m, and each row had a length of 70 m.

2.3.2 Field speed measurement

Travelling speed was calculated by timing the machine as it travelled a distance of 30 meters between two poles placed opposite each other in the field. This process was repeated five times, and the average of these readings was used to determine the machine's travelling speed in km/hr.

2.3.3 Heart rate

Heart rate is a key indicator of circulatory function and is determined by the number of heartbeats per unit of time, usually expressed as beats per minute (beats/min). In this study, heart rate was measured using a Polar Heart Rate Monitor.

2.3.4 Overall discomfort rate (ODR)

Overall discomfort rate (ODR) was measured using a 10-point psychophysical rating scale developed by Borg (1990). A 70 cm scale with equidistant markings from 0 to 10 was used, and participants indicated their discomfort rating using a movable pointer. The ratings provided by ten subjects were averaged to calculate the mean discomfort rating.

2.3.5 Body part discomfort score (BPDS)

To measure localized discomfort, Corlett and Bishop (1976) technique was used. In this technique the subject's body was divided into 27 regions shown in the figure. The subject was asked to mention all body parts with discomfort, starting with the worst, the second worst and so on until all parts have been mentioned (Lusted *et al.* 1994). The subject was asked to fix the pin on the body part in the order of one pin for maximum pain, two pins for next maximum pain and so on (Legg and Mohanty, 1985). The number of different groups of body parts, which were identified from extreme discomfort to no discomfort, represented the number of intensity levels of pain experienced.

2.4 Energy analysis in developed battery operated ground wheel boom sprayer

Efficient energy use in agriculture is vital for sustainability due to population growth, limited land, and higher living standards. Energy inputs vary based on farming systems, seasons, and conditions. Promoting precision agriculture, renewable energy, and efficient machinery improves sustainability and supports food security and economic development. Various energy factors were examined, including power input type (such as battery-powered sprayer), power output of the battery (measured in horsepower), energy consumption (in kilowatt-hours), labor input (measured in man-hours), fertilizer usage (in kilograms of N-P-K), chemical substance usage (in kilograms or liters), working time (in hours), and cultivation area (measured in ha). The spraying process took 5 hours to cover 1 hectare of land. The sprayer had a weight of 5 kg, and its working life was considered to be 2000 hours. The energy inputs data were changed to the energy consumption in unit MJ/ha by using equation (1) to (4) and energy equivalent of all required energy shown in Table 1.

Table 1: Energy equivalent in agricultural operation

Energy types	Energy equivalent	Unit	References
Human energy	1.96	h	Yilmaz et al. (2005)
Machinery	62.70	h	Singh (2002)

Superior chemical	120	kg	Singh (2002)
--------------------------	-----	----	--------------

Human energy (E_h)

$$E_h \text{ (MJ/ha)} = \text{Energy equivalent value of human (MJ/h/man)} \times \text{Farmer (man)} \times \text{Working Time (hour)} \times \text{Working area (ha)} \dots\dots (1)$$

Chemical energy (E_c)

$$E_c \text{ (MJ/kg)} = \text{Chemical used (kg)} \times \text{Equivalent energy of chemicals (MJ)} \dots\dots(2)$$

Mechanical energy (E_m)

$$E_m \text{ (MJ/ha)} = (\text{weight (kg)} / (\text{life(hr)})) \times \text{Time required (hr)} \times \text{Equivalent energy of farm machinery(MJ)} \dots(3)$$

$$\text{Total energy in spraying} = \text{human energy} + \text{chemical energy} + \text{mechanical energy} \dots(4)$$

2.5 RESULT AND DISCUSSION

The study comprised two stages: laboratory experiments and field evaluations, to assess the performance of a battery-operated boom sprayer (Figure 3 and 4). In the laboratory, parameters such as nozzle discharge rate, coverage uniformity, swath width, spray overlap, and spray angle were examined, considering factors like nozzle type, height, number, and pump stroke length. The field tests were conducted in a brinjal crop to calculate field capacity and efficiency. The results, along with discussions, shed light on the impact of independent parameters on dependent variables, providing valuable insights into the sprayer's performance under various conditions (Table 2.)

Table 2: Detail of various parameters were taken

Independent parameters	Level	Dependent parameters
Nozzle type	2	Nozzle discharge rate l/min
Nozzle height	2	Uniformity of coverage
No. of nozzles	2 (3,4)	Spray overlap
Pump stroke	2	Spray angle



(a) (b)

Fig.3 Experiment setup Sprayer patternator setup



(a) (b)

Fig.4 Machine test in field

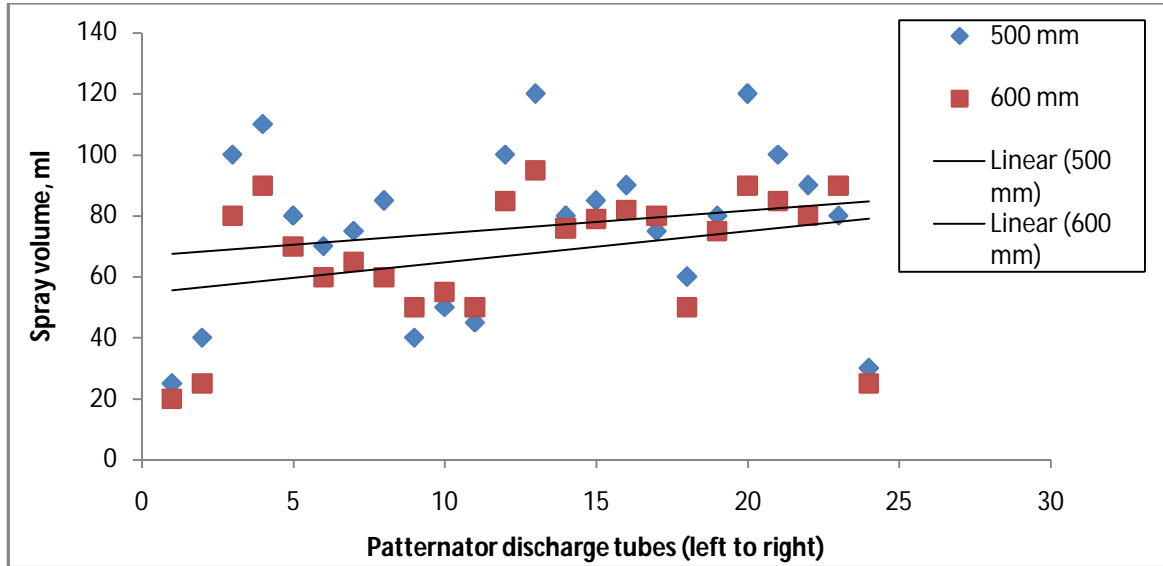

Fig.5 Effect of nozzle height on spray volumetric distribution of single hole brass hollow cone nozzle at 4 cm stroke length.

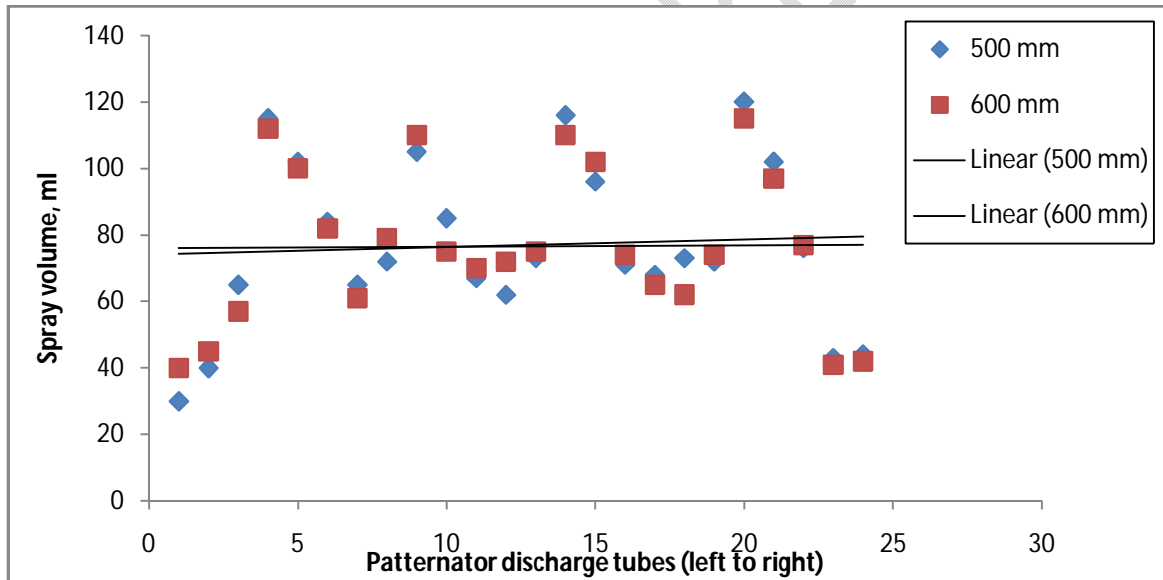

Fig.6 Effect of nozzle height on spray volumetric distribution of single hole brass hollow cone nozzle at 4.5 cm stroke length

The figures presented depict the effect of nozzle height (500 mm and 600 mm) on the distribution pattern. Analysis of the curves reveals a consistent trend wherein the maximum values are observed near the center of each nozzle, gradually decreasing towards the ends. This observation suggests that the spray distribution tends to be more concentrated at the center. The quantitative data further supports these findings, with the

total and average discharge values obtained at a 4 cm stroke length (Fig. 5) being 1830 ml/min and 76.25 ml/min, respectively, at the 500 mm height, and 1617 ml/min and 67.37 ml/min, respectively, at the 600 mm height. Similarly, at a 4.5 cm stroke length (Fig. 6), the total and average discharge values were 1846 ml/min and 76.91 ml/min, respectively, at the 500 mm height, and 1765 ml/min and 73.54 ml/min, respectively, at the 600 mm height. These results highlight the impact of nozzle height on the spray distribution and provide valuable insights for optimizing the system's performance.

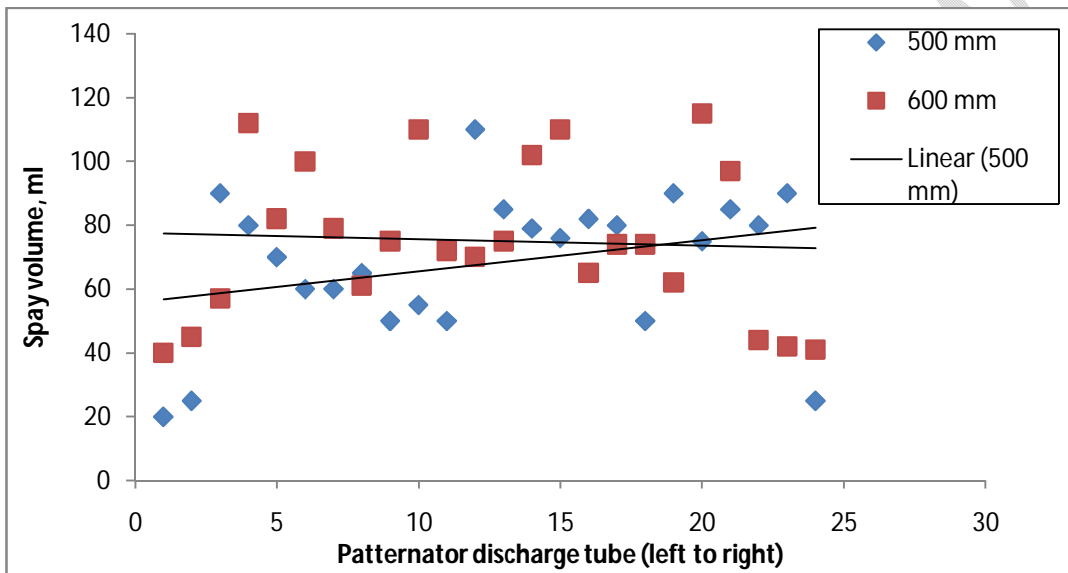

Fig.7 Effect of nozzle height on spray volumetric distribution of five hole hollow cone nozzle at 4 cm stroke length.

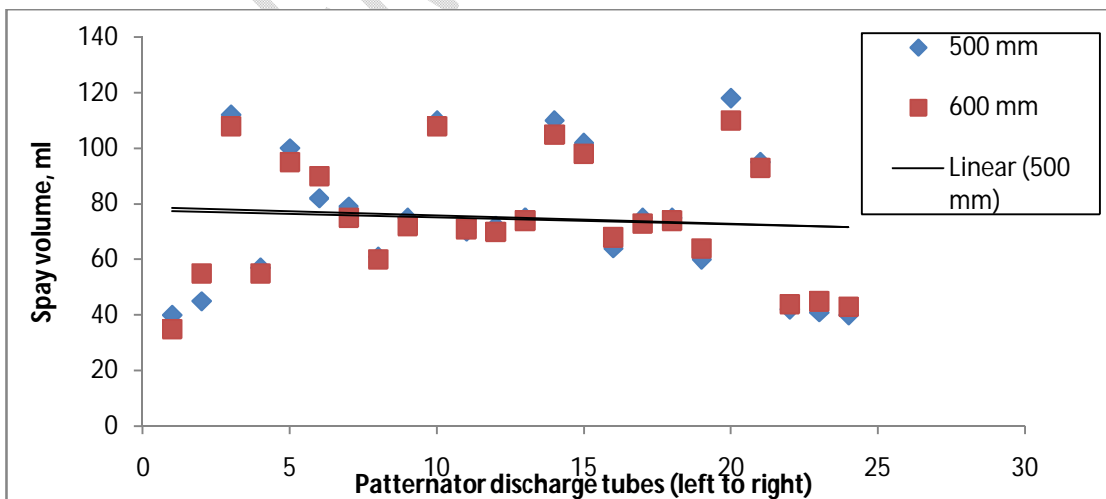

Fig.8 Effect of nozzle height on spray volumetric distribution of five hole hollow cone nozzle at 4.5 cm stroke length.

Figures 7 and 8 present the volumetric distribution of a five-hole brass hollow cone nozzle at different stroke lengths and heights. The trend lines in the figures reveal a consistent pattern where the curves reach maximum values near the **center** of each nozzle and gradually decline towards the ends. For instance, at a 4 cm stroke length and 500 mm height, the total and average discharge were 1632 ml and 68 ml, respectively. When the height increased to 600 mm, the values rose to 1804 ml and 75.16 ml, respectively (Fig. 7). Similarly, at a 4.5 cm stroke length, the total and average discharge at the 500 mm height were 1785 ml and 74.375 ml, while at the 600 mm height, they were 1800 ml and 75 ml, respectively (Fig. 8). The findings indicate that as the nozzle height increased, the average discharge decreased, and the curves became wider. This suggests that higher nozzle heights result in a broader spray pattern with lower peak discharge values.

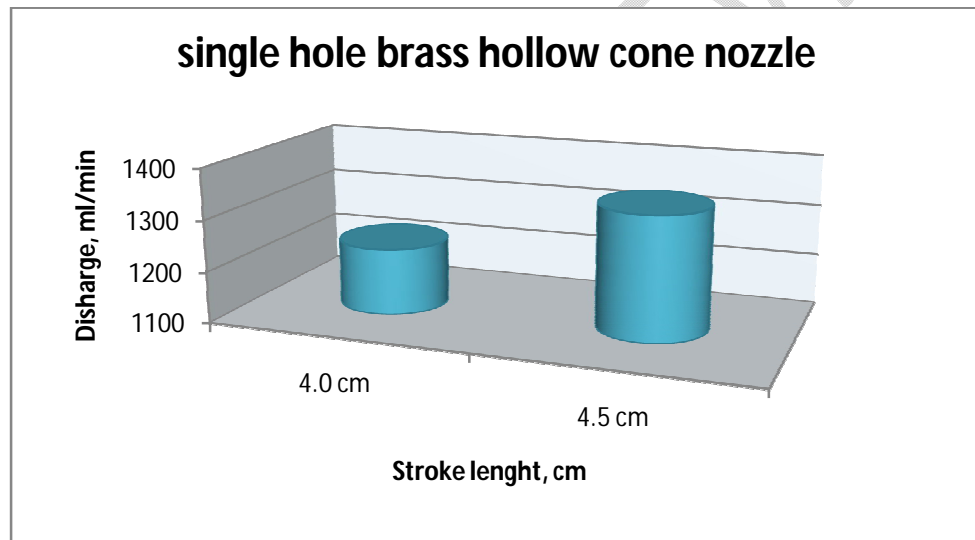

Fig.9 Effect of different stroke length on discharge in single hole brass hollow cone nozzle.

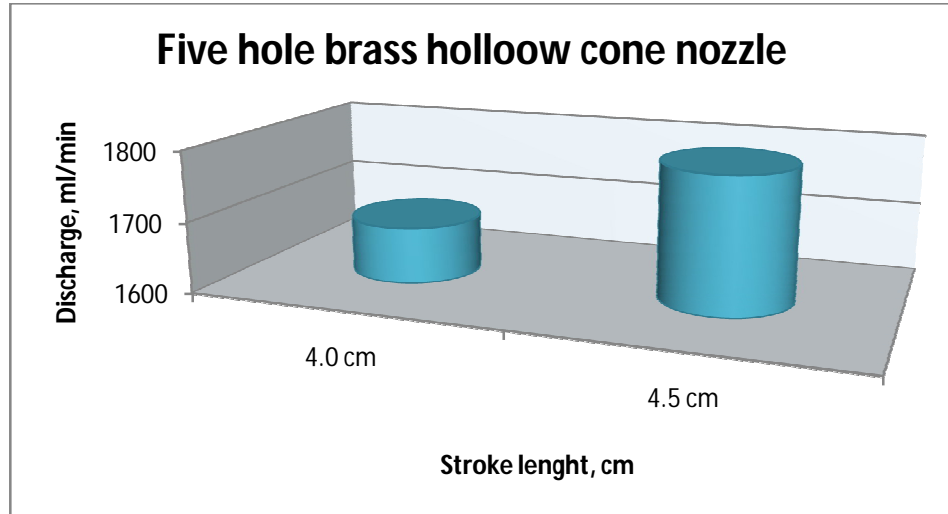

Fig.10 Effect of different stroke length on discharge in five-hole brass hollow cone nozzle

The rate of discharge for a five-hole brass hollow cone nozzle exhibited variations between 1625.3 ml/min and 1710.4 ml/min at a 4 cm stroke length, and from 1762.5 ml/min to 1800.3 ml/min at a 4.5 cm stroke length. These findings highlight the dynamic nature of the discharge rate, emphasizing the influence of stroke length on the spray performance. The range of values underscores the importance of precise stroke length adjustment for achieving desired discharge rates in agricultural spraying applications.

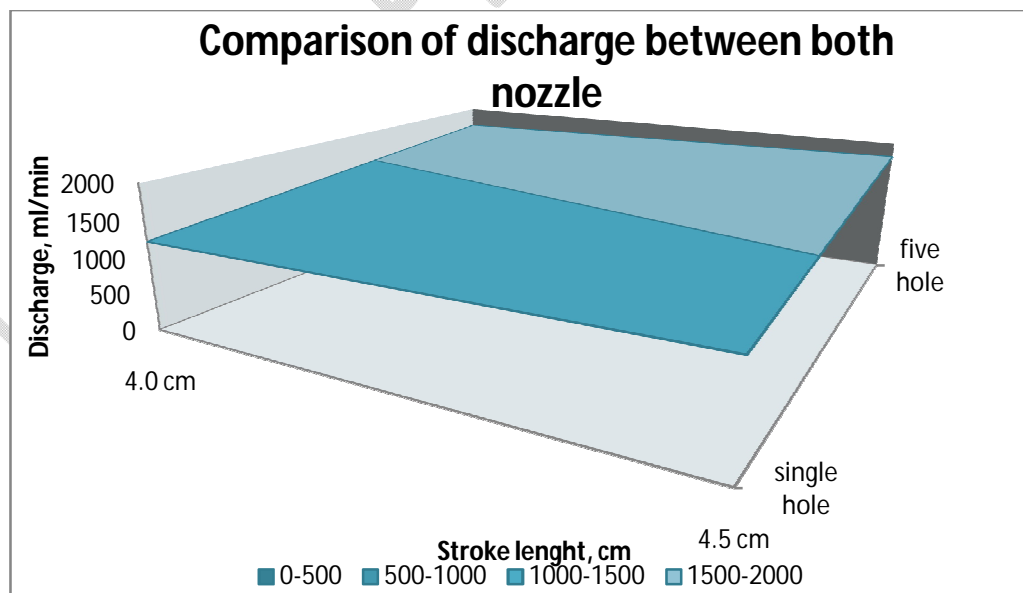

Fig.11 Comparison of discharge between single hole nozzle and five hole nozzle at different stroke length

The disparity in discharge rates between different stroke lengths and nozzle types can be attributed to the variations in design and functionality. The five-hole brass hollow cone nozzle is specifically designed to deliver a larger volume of spray, resulting in significantly higher mean discharge rates of 1680.2 ml/min and 1790.0 ml/min at stroke lengths of 4 cm and 4.5 cm, respectively (Figure 11.). In contrast, the single-hole brass hollow cone nozzle is engineered for a different purpose, resulting in comparatively lower discharge rates of 1230.0 ml/min and 1340.0 ml/min at the corresponding stroke lengths. These findings highlight the direct impact of nozzle design and configuration on the overall spray performance and emphasize the advantage of using the five-hole brass hollow cone nozzle for applications requiring higher discharge volumes.

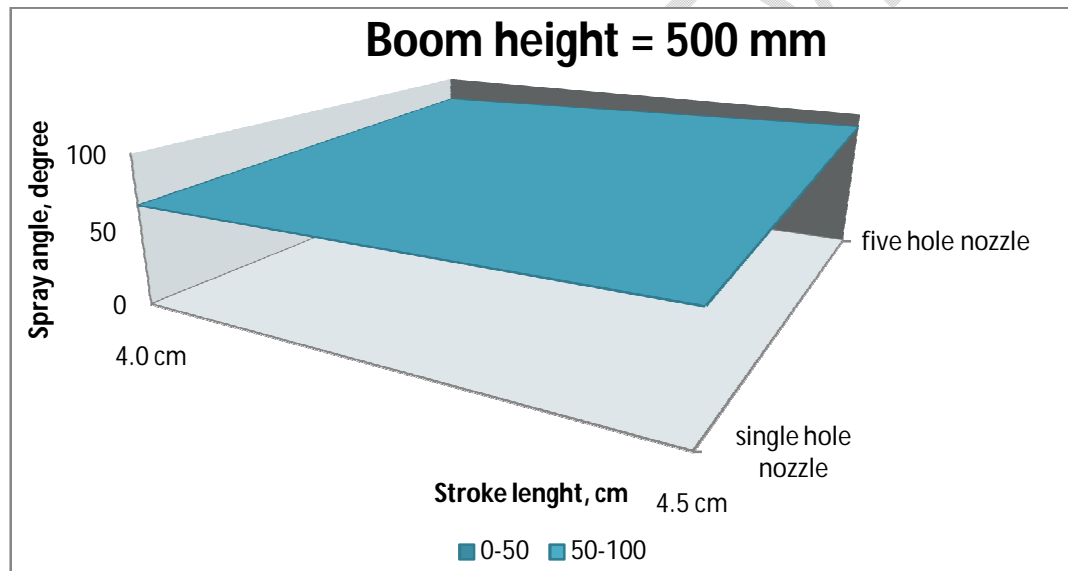

Fig.12 Effect of different types of nozzles at different stroke length on angle of spray at 500 mm boom height

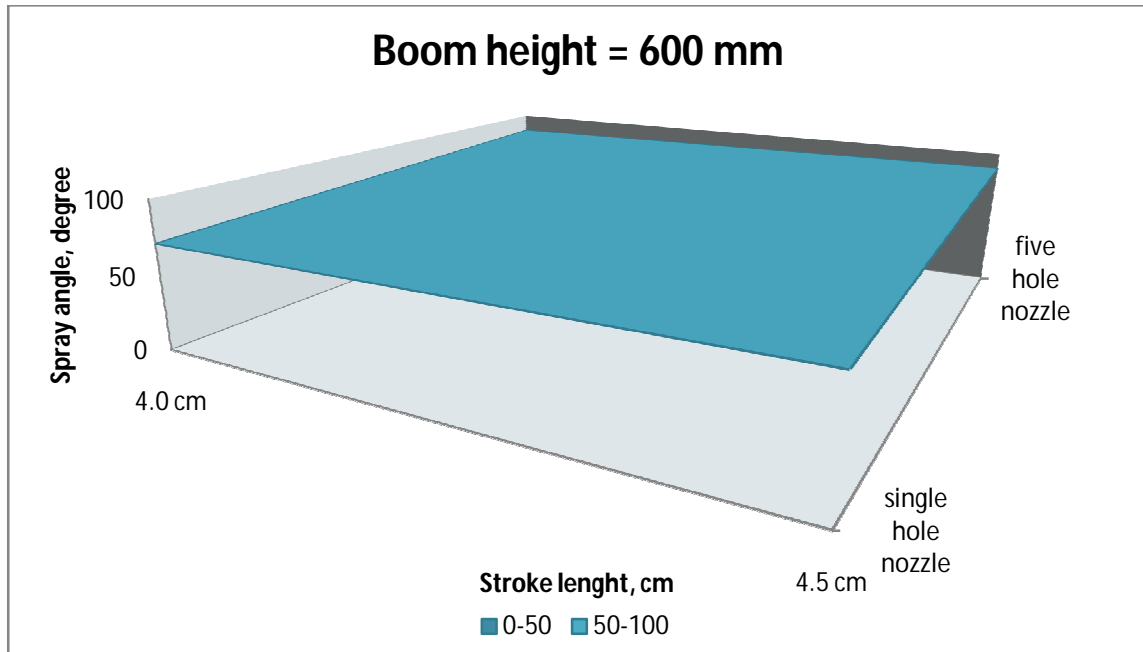

Fig.13 Effect of different types of nozzles at different stroke length on angle of spray at 600 mm boom height

The analysis of the angle of spray measurements reveals significant differences between the single-hole and five-hole brass hollow cone nozzles (Fig. 12 and 13). At a boom height of 500 mm and a stroke length of 4.0 cm, the single-hole nozzle exhibited an angle of spray ranging from 65.2 to 69.3 degrees, while the five-hole nozzle demonstrated a wider spray angle ranging from 80.4 to 82.3 degrees. Similarly, at a boom height of 500 mm and a stroke length of 4.5 cm, the single-hole nozzle had an angle of spray ranging from 71.9 to 74.2 degrees, whereas the five-hole nozzle displayed a significantly wider spray angle ranging from 88 to 90.8 degrees. At a boom height of 600 mm and a stroke length of 4.0 cm, the single-hole nozzle exhibited an angle of spray ranging from 68.5 to 72.6 degrees, and the five-hole nozzle showcased a wider spray angle ranging from 83.3 to 86.6 degrees. Finally, at a boom height of 600 mm and a stroke length of 4.5 cm, the single-hole nozzle had an angle of spray ranging from 74.2 to 78.3 degrees, while the five-hole nozzle displayed a wider spray angle ranging from 85.3 to 88.3 degrees. These findings emphasize that the nozzle type, stroke length, and boom height significantly impact the angle of spray, with the five-hole brass hollow cone nozzle offering a wider coverage compared to the single-hole nozzle.

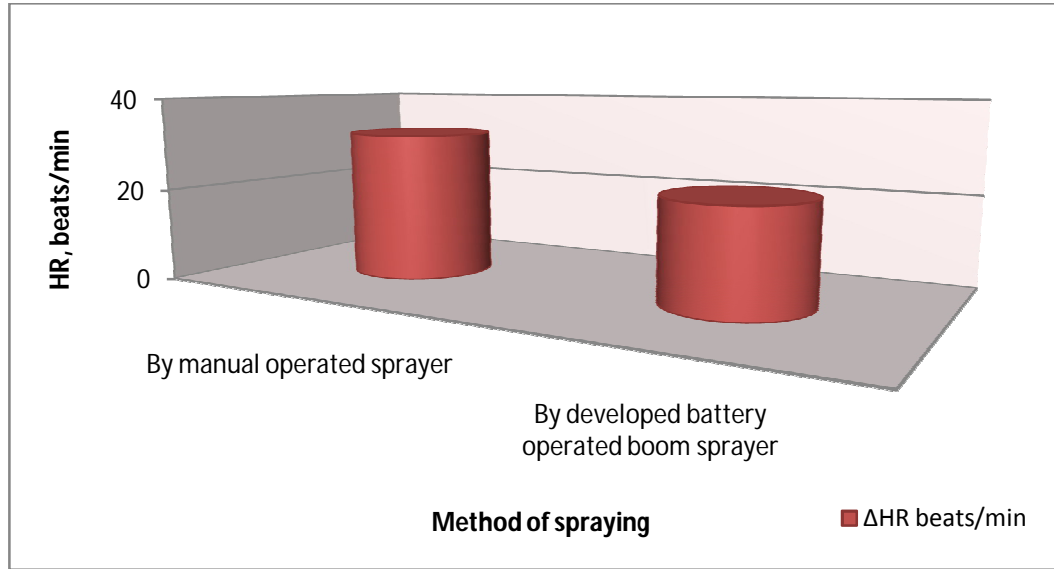

Fig.14 Effect of spraying operation on heart rate (beats/min)

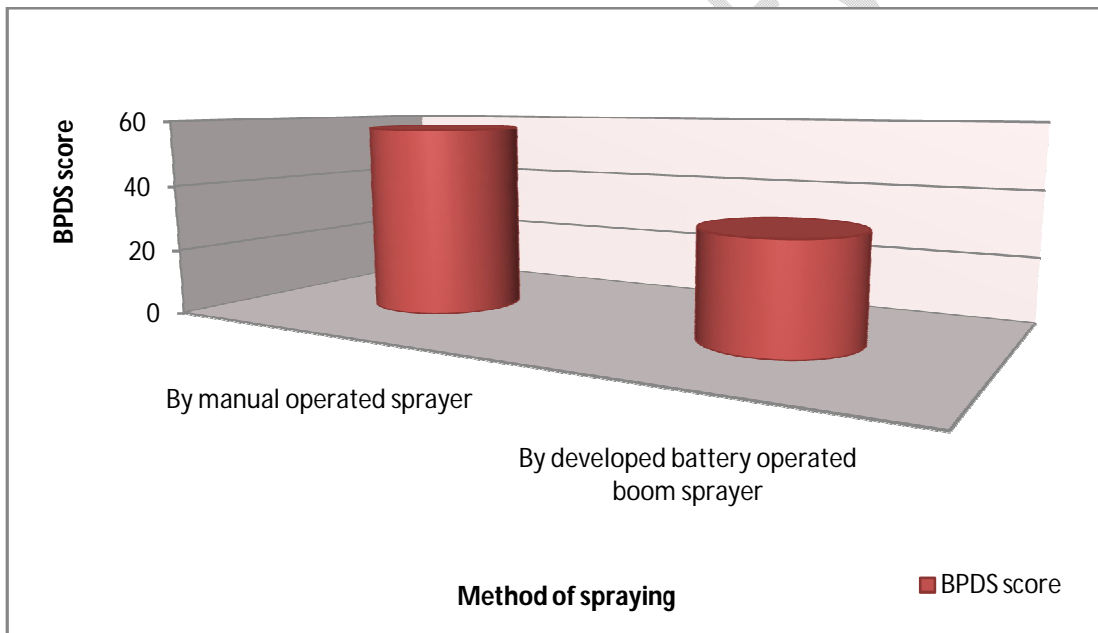

Fig.15 Effect of spraying operation on BPDS score

The heart rate measurements during resting and working periods were recorded for two spraying methods: manual operation and the developed battery-operated boom sprayer (Fig. 12). The manual operation resulted in heart rate values ranging from 76.3 to 81.4 beats/min during rest and 104.5 to 116.3 beats/min during work, with average rates of 79.48 beats/min and 111.44 beats/min, respectively. In contrast, the battery-operated boom sprayer exhibited heart rate values ranging from 78.3 to 85.2 beats/min during rest

and 101.7 to 106.1 beats/min during work, with average rates of 82.34 beats/min and 104.1 beats/min, respectively (Fig. 13). The lower heart rate levels observed during work with the battery-operated boom sprayer can be attributed to the reduced physical exertion required, as it operates mechanically. In contrast, the manual operation involves repetitive arm movements and manual pump operation, resulting in higher heart rates.

2.6 Energy analysis

Analysis of energy consumption in **humans'** energy, chemical energy and machinery are done through table conversion and using equation 1-3. The total energy consumption for spraying operation is 208.583 MJ/ha. The human labour energy input employed in spraying was 9.8MJ ha⁻¹ (Table 1.) which was mainly used for operating machine and spraying. Application of chemical pesticides utilized 198MJ ha⁻¹ (Table 1.). The total mechanical energy was considered as 0.783 MJ/ha. The results of the current study revealed that spraying in maize, under current pest management practices, is energy efficient.

2.7 CONCLUSION

In summary, the experimental findings encompass various aspects of the performance evaluation of the sprayer. The rate of discharge was found to increase with longer stroke lengths and was higher for the five-hole brass hollow cone nozzle compared to the single-hole nozzle. The angle of spray also increased with longer stroke lengths and nozzle height, with the five-hole brass hollow cone nozzle demonstrating a superior spray angle. Key performance metrics, such as theoretical field capacity, effective field capacity, field efficiency, spray application rate, and speed of operation, were measured and provided insights into the sprayer's operational capabilities. Additionally, physiological measurements, including average heart rate, body part discomfort score, and overall discomfort rating, shed light on the operator's comfort during operation. Lastly, a cost comparison indicated that the developed battery-operated boom sprayer had a lower cost of operation per hectare compared to the ground wheel-operated sprayer.

Ethics declarations: Consent for publication

Not applicable.

References:

- Borg, G. (1990). Psychophysical scalin with applications in physical work and the perception of exertion.*Scandinavian journal work Environmental* 16: 55-58.
- Corlett, E.H. and bishop, R.P. (1976).A technique for assessing postural discomfort.*Ergonomics* 2: 175-182.
- Ghugare, B.D., Adhaoo, S.H., Gite, L.P., Pandya, A.C. and Patel, S.L. (1991). Ergonomics evaluation of a lever operated knapsack sprayer. *Applied Ergonomics* 4: 241-250.
- Gite, L.P. and Yadav, B.G. (2007). Optimum handle height for a push-pull type manually- operated dry land weeder. *Journal Ergonomics* 33: 1487-1494.
- Gururaj, T.R., Mallesh, K.U., Basavaraj and Chaitanya, (2020). Development and performance evaluation of cycle mounted battery operated boom sprayer. *International Journal of Agriculture Sciences*.12 pp.-10503-10505.
- Karale, D.S., Kankal, U.S., Khambalkar, V.P. and Gajakos, A.V. (2014).Performance evaluation of self propelled boom sprayer.*International Journal of Agricultural Engineering*7: 137-141
- Kepner, R.A., Bainer, R. and Barger, E.L. (2005).Principles of farm machinery.*CBS Publication & Distribution PVT. LTD.* pp: 25-26.
- Khurmi, R.S .and Gupta, J.K. (2008).A text book of machine design.*Eurasia publishing house (PVT.) LTD. Ram Nagar, New Delhi* pp.509-763.
- Kumar, C.S. (2015). Development and performance evaluation of single wheel drive boom sprayer. *International Journal of Agricultural Science and Research* 5:277-285.
- Kumar, G.H., Kumar, A.A., Kumar, E.P., and Ramana, M. V. (2015). Physiological evaluation of manual operated weeders and sprayers on farm use.*International Journal of Agricultural Engineering* 4: 173
- Kumar, S.A., and Murthy, P.D. (2014).Development of wheel driven sprayer.*International Journal of Engineering Research* 2: 2321-7758.
- Legg, S.J. and Mohanty, A. 1985.Comparison of five modes of carrying a load close to the trunk.*Ergonomics*28: 1653-1660.
- Liu, G.Q., Zhang, G. and Li, J. (2008).Source and distribution characteristic of atmospheric organochlorine pesticides in the pearl river estuary and adjacent South China sea. *Environmental Science* 29: 3320-3325.
- Lusted, M., Healey, S. and Mandryk, J.A. (1994). Evaluation of the seating of Qantas flight deck crew.*Applied Ergonomics* 25: 275-282.
- Mathur, S.C. (1999). Future of Indian pesticides industry in next millennium.*Pesticide Information* 24: 9-23.
- Mulatu, Y. (2018). Fabrication and performance evaluation of ground wheel operated boom sprayer. *International Journal of Engineering Research* 6:16-23.

- Sahay, J. (2008). Text book of elements of agricultural Engineering. *Standard publisher distributor's* pp. 233-235.
- Sen, R.N. (1969). Classification of strains in different types of jobs according to the physiological responses of Indian workers in comfortable climates. ICMR report. Indian Council of Medical Research, New Delhi.
- Sharma, D.N. and Mukesh, S. (2013). Farm machinery design principle and problems. *Jain brothers (new delhi)*. pp:215-220.
- Singh, G. and Sahay, K.M. (2001). Research development and technology dissemination. *A silver jubilee publication*. CIAE, Bhopal, India.
- Singh, K., Padhee, K., Parmar, A.K. and Sinha, B.L. (2018). Development of a solar powered knapsack sprayer. *Journal of Pharmacognosy and Phytochemistry* 1: 1269-1272.
- Singh, S. (2016). Farm tools and equipment for agriculture. New India publishing Agency pp. 571-572.
- Singh, S., Padhee, D., Sonwani, S, and Trishala, S. (2020). Design, fabrication and evaluation of wheel operated sprayer. *International Journal of Current Microbiology and Applied Science* 9: 1649-1659.
- Singh, K., Singh, S. and Verma, G. (2018). Evaluate the performance of multiple powered knapsack sprayer in the field and laboratory. *International Journal of Fauna and Biological Studies* 5: 148-151.
- Sinha, J.P., Singh, J.K., Kumar, A. and Agarwal, K.N. (2018). Development of solar powered knapsack sprayer. *Indian Journal of Agricultural Sciences* 88: 590-5.
- Tamilselvi, P., and Krishnan, D. (2016). Ergonomics evaluation of conventional agricultural sprayers with respect to human performance. *Agricultural Science Digest* 36 : 179 – 184.
- Wang, L., Zhang, N., Slocombe, J.W. and G.E. (1995). Experimental analysis of spray distribution pattern uniformity of agricultural nozzles. *Applied Engineering in Agriculture* 11: 51-55.
- Wolman, M.G. and Fournier F. G. A. (1987). *Plant Protection and Land Transformation*. John Wiley and Sons, Inc., New York.
- Dey, P., Banerjee, A., Saha, A., & Sarkar, S. (2019). Evolution of Indian agriculture: A review. *International Journal of Agricultural Science and Research*, 9(1), 1-10.
- Ghosh, S., Chakraborty, P., & Ghosh, S. (2021). Plant protection strategies: An overview. In *Sustainable Agriculture and Environmental Challenges* (pp. 155-182). Springer.
- Gupta, R., Rani, M., & Singh, A. (2018). Role of pesticides in agriculture and their hazardous impacts on human beings and environment. In *Environmental Sustainability* (pp. 131-145). Springer.
- Kumar, R., Mishra, V. K., & Choudhary, D. (2020). Modern agricultural practices: A review. *International Journal of Chemical Studies*, 8(4), 1497-1502.
- Singh, R. K., Sodhi, N. S., & Meher, M. (2017). *Field crop pests: ecologically-based approaches for management*. CRC Press.
- Wolman, M. G., & Fournier, F. (1987). *Integrated pest management for crops and pastures*. CRC Press.

- Singh, J.M. (2002). On farm energy use pattern in different cropping systems in Haryana, India. Master of Science. Germany: International Institute of Management, University of Flensburg.
- Singh, H., Mishra, D. and Nahar, N.M. (2002). Energy use pattern in production agriculture of a typical village in Arid Zone India—Part I. *Energy Conversion and Management* 43(16): 2275–2286.
- Yilmaz, I., Akcaoz, H. and Ozkan, B. (2005). An analysis of energy use and input costs for cotton production in Turkey. *Renewable Energy* 30: 145–155.

UNDER PEER REVIEW