

Innovative Design of a Whole-stem Sugarcane

Harveste

ABSTRACT

The small whole-stem sugarcane harvester is a type of sugarcane harvesting machinery designed for individual farmers. It ensures a complete cutting plane during the harvesting process, resulting in low sugarcane head breakage and reduced sugar loss. The sugarcane harvesters currently developed mainly come in two forms: whole-stem and cut-stem. The cut-stem harvesters are larger in size and more expensive, making them unsuitable for the hilly terrain and small-scale cultivation in China. The whole-stem harvesters have poor adjustability of the cutting platform, leading to uneven stubble and high head breakage rates, making it difficult for farmers to choose the right sugarcane harvesting machinery. Currently, the aforementioned issues have not been effectively addressed. Therefore, this paper designs a low-cost, rationally structured, easy-to-operate, and individual-farmer-friendly small whole-stem sugarcane harvester that can efficiently complete sugarcane harvesting tasks.

Keywords: Agricultural mechanization; Cost-effective; Structural design; Harvesting technology

1.INTRODUCTION

Sugarcane, known for its high sugar content, is widely cultivated around the world. Thus, the quality and efficiency of the sugarcane industry have become crucial for the healthy development of the sugar industry. Currently, most sugarcane harvesting relies on traditional manual labor, which is labor-intensive and has low efficiency. Statistics show that the overall mechanical usage rate is only 15% during the entire harvesting process, with mechanical usage accounting for about 3% during the actual harvesting phase, which constitutes over 70% of the entire process. The reason is the lack of suitable harvesting machinery. Manual harvesting of sugarcane not only results in unstable cutting quality, long time consumption, and uncertain efficiency but also incurs high labor costs, increasing the economic burden on farmers and reducing their income[[1]]. Sugarcane harvesting methods are mainly divided into cut-stem and

whole-stem. Large cut-segment sugarcane harvesters have high harvesting efficiency, rich functions, and low head breakage and impurity rates[2]. However, due to the hilly terrain, uneven fields, diverse planting ridge specifications, small-scale cultivation, and individual farming in these areas, large cut-segment sugarcane harvesters cannot be widely applied, and their costs are relatively high compared to other harvesting machinery. Additionally, due to the technical limitations of sugar factories, the production model of sugar factories requires sugarcane to be processed within 16 hours after harvesting, and cut-stem harvesting leads to significant sugar loss.

Therefore, considering the terrain, planting methods, and processing requirements of sugar factories, whole-stem sugarcane harvesters are currently used to complete sugarcane harvesting[[2]]. However, there are still some shortcomings in the whole-stem sugarcane harvesters that have been developed. For example, poor adjustability of the cutting platform leads to reduced harvesting efficiency; high head breakage rate affects the secondary growth of sugarcane; and the harvested sugarcane contains more impurities, leading to high impurity rates, causing blockages in the conveying device, and resulting in uneven conveying[[4]]. However, in the future development of sugarcane harvesting mechanization, the development of whole-stem sugarcane harvesters remains the most suitable. From the above analysis, it is evident that the current sugarcane harvesting methods are still relatively backward[[5]], and there are still significant issues with sugarcane harvesting machinery technology[[6]]. Under these circumstances, it is necessary to develop small, lightweight, economical, and farmer-friendly sugarcane harvesting machinery that can achieve functions such as cutting, conveying, laying, and collecting, meet the complex and diverse agricultural technical requirements of sugarcane, and provide technical support for improving the efficiency and quality of sugarcane harvesting[[7]].

2. MATERIALS AND METHODS

2.1 Design Requirements

(1) Product positioning: This product is a small-scale sugarcane harvester primarily designed for small to medium-sized sugarcane plantations.

(2) Cutting quality: Criteria include neat and aesthetically pleasing cuts that do not adversely affect sugarcane regrowth the following year, aiming for a standard with a stalk breakage rate of less than 20%.

(3) Laying quality: Post-harvest, sugarcane should be laid out neatly to facilitate

subsequent operations.

(4) Operational efficiency: The harvester must meet agronomic requirements for efficiency and cost-effectiveness. During operation, it should achieve higher harvesting efficiency per unit time compared to manual labor.

(5) Transmission system: The transmission structure should be simple, low-power, long-lasting, low-vibration, and provide smooth operation, facilitating easy installation and maintenance.

(6) Spatial requirements: The overall dimensions should be appropriate, occupying minimal space, with machine design facilitating mobility and transportation.

(7) Operational requirements: The sugarcane harvester should be user-friendly with simple operation, ensuring user safety in the event of malfunctions.

In response to the aforementioned requirements, the small whole-stem sugarcane harvester designed in this paper aims to achieve the following main functions: cutting, conveying, laying, power transmission, and support functions. To meet these functional requirements, this paper will conduct in-depth research and detailed design on the cutting system, conveying system, transmission system, and support system. Below are the specific design plans for each system.

2.2 Sugarcane Cutting System

As shown in Fig.1, this is the structural diagram of the cutting system for the designed small whole-stem sugarcane harvester. The hydraulic motor 6 is fixed together with the motor flange 5. The output shaft of the hydraulic motor is connected to the main shaft of the gear transmission group via an internal spline key. The rotation of the main shaft drives the gear to rotate 7, and the two are connected by a key. The gear transmission enables both knife shafts 3 to rotate in opposite directions at the same speed. The sleeve 10 is fixed to the bottom of the gearbox 4 with bolts. The exterior of the knife shaft 3 is equipped with two tapered roller bearings, which are fixed by the embedded end covers and the sleeve 10 at both ends. The knife shaft 3 is connected to the disc 2 through a taper fit, and the disc 2 is driven to rotate by adjusting the axial displacement of the knife shaft 3 with a nut to achieve an interference fit. The multi-blade knife 1 is connected to the disc 2 with bolts, which facilitates installation and replacement. Some components are shown in Fig. 2.

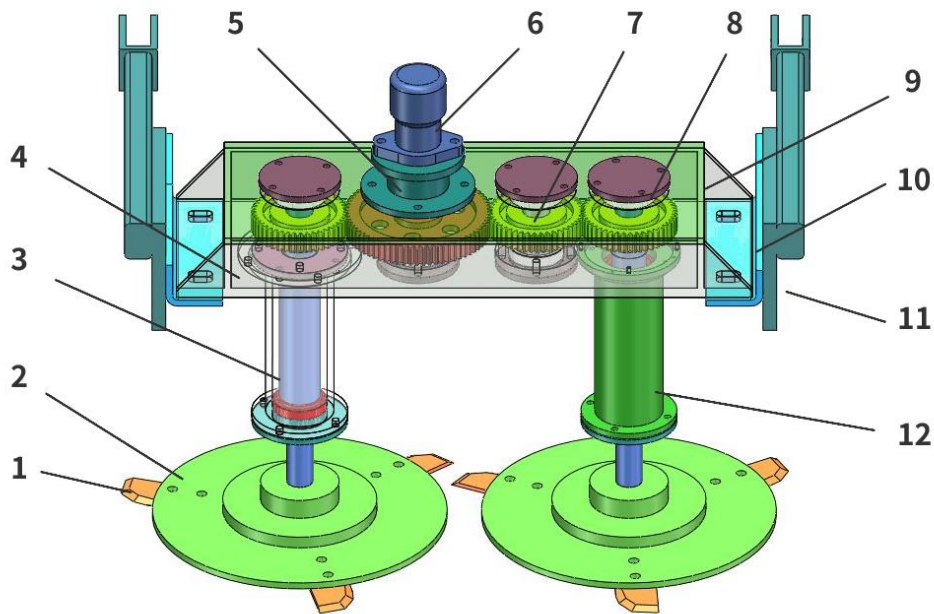

1. Multi-blade cutter 2. Disc 3. Cutter shaft 4. Gearbox base 5. Motor flange
 6. Hydraulic motor 7. Gear transmission group 8. Deep groove ball bearing
 9. Gearbox top cover 10. Connecting frame 11. Support frame 12. Sleeve.

Fig. 1. Sugarcane Cutting System

This paper selects a disc cutter for sugarcane harvesting operations, considering the use of a double-disc cutter to reduce inertial vibration[8]. The cutting system mainly consists of a gear box, two cutting blades, discs, a cutter shaft, and a support frame. The power transmission mainly relies on the hydraulic system to drive the rotation of the hydraulic motor's transmission shaft, enabling the straight gears inside the gear box to transmit power[9]. The cutter shaft rotates through the gears on both sides, and the cutter shaft is connected to the disc, thus achieving the harvesting of sugarcane. The upper end of the cutter shaft is connected to the gear with a key, and the lower end has threads, which are fixed to the disc with a nut. The blade is fixed to the disc with bolts, and four blades are installed at the bottom end of the disc, with the blades of the left and right discs set in an alternating manner. When the sugarcane harvester is in motion, if the blade is damaged by cutting a stone, it can quickly select, correct, or replace different types of blades to ensure cutting efficiency and a lower head breakage rate.

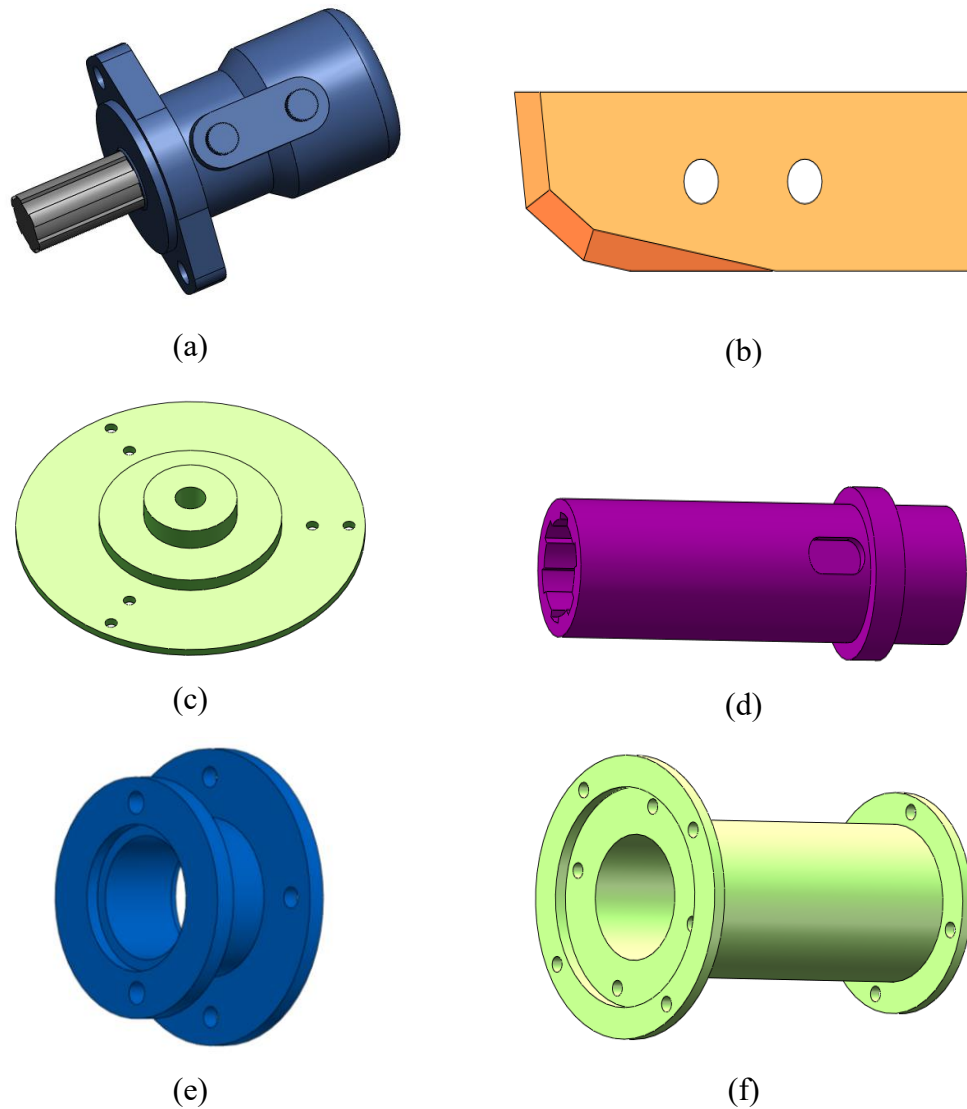

Fig. 2. Components of the Cutting System

(a)Hydraulic motor (b)Multi-blade cutter (c)Disc (d)Power Shaft (e) Motor flange (f)Sleeve

2.3 Conveying System

The structure diagram of the conveying system for the small whole-stem sugarcane harvester is shown in Fig. 3. The conveying system is mainly composed of five parts: the conveying chain, the actuating device, the drive shaft, the tensioning device, and the support device. The conveying chain includes the chain 7, the drive sprocket 9, and the idler sprocket 3. The design involves adding some auxiliary holes on the chain, and the connection between the actuating device 1 and the chain is completed with bolts. The tension of the sprockets is adjusted by changing the position of the adjustment screw 6, which alters the center distance of the conveying chain, and is equipped with self-aligning roller bearings 9 to ensure the normal operation of the drive shaft. The

connecting frame 7 is fixed to the top cover 5 with bolts. The drive shaft drives the sprocket to rotate via a key, enabling the actuating device on the chain to complete a circular motion, thereby moving the cut sugarcane to the left rear of the cutter, fulfilling the conveying and laying functions for the sugarcane.

Considering that the sugarcane harvester requires a simple structure and low cost, the conveying system is proposed to use a chain-tooth type for sugarcane transportation. This conveying system includes components such as sprockets, chains, and sprocket teeth. The sprocket is mounted on the upper end of the support system through a transmission shaft. Through the rotation of the transmission shaft, the sprocket drives the chain to rotate. The sprocket teeth are evenly distributed on the outer surface of the chain, and the teeth can separate the sugarcane from the cutting system and complete the transportation. The conveying system has a certain distance from the cutting system in the horizontal direction to ensure that the sugarcane can be normally moved after cutting. During the laying process, it mainly relies on the installation of an arc-shaped baffle at the end of the chain. When the sugarcane is transported to the baffle, it can change the direction of the sugarcane's movement and achieve transverse laying of sugarcane.

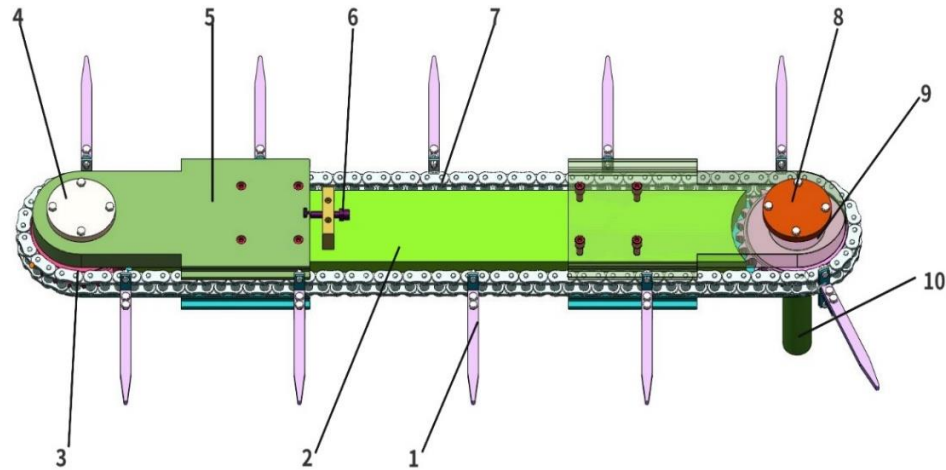

1. Rake tooth 2. Connecting frame 3. Idler sprocket 4. Bearing cover 5. Top cover
6. Adjusting bolt 7. Chain 8. Self-aligning roller bearing 9. Drive sprocket
10. Drive shaft. **Fig. 3. Conveying System**

2.3.1 Design of the Actuating Device

As shown in Fig 4, it is the structural diagram of the actuating device. The actuating device consists of two parts, specifically including the actuating teeth and the plate reinforcement. The total length of the actuating teeth is 225mm, and the width is 18.5mm. The installation height of the actuating teeth is in the middle-upper part of the

sugarcane, and the shape of the actuating teeth adopts a long-tooth structure, which can more stably complete the actuation of the sugarcane and transport it. The actuating teeth are connected to the plate reinforcement with two bolts of diameter M8, and the material of the actuating teeth is selected as HT150.

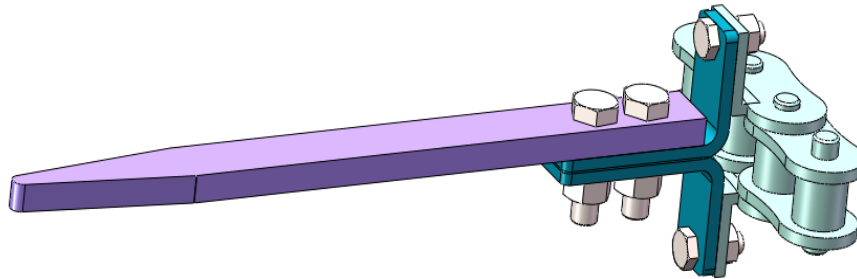

Fig. 4. Actuating device

A part of the chain protrudes outward, welded together with the chain, and there is a bolt hole with a diameter of M6, which facilitates connection with the plate reinforcement. The shape of the plate reinforcement is designed as an L-shape, with the purpose of connecting the actuating teeth with the chain, and the material of the plate reinforcement is Q235.

2.4 Transmission System

The diesel engine of the tractor provides power, which is transmitted to the transmission system via a belt. The power is then transmitted to the cutting and conveying systems. The transmission system mainly includes belts, pulleys, and bevel gear changers. Based on the designed specifications and dimensions of the cutting and conveying systems and the maximum load, the required power is calculated, and an appropriate transmission ratio is selected. Belt transmission operates with low noise, has elastic buffering, and shock absorption, making the movement process more stable. It does not require high manufacturing and installation standards, and does not need lubrication during operation. When the work encounters overload, the belt will slip on the pulley, providing a certain level of protection[10]. Some components of the transmission system are shown in Fig. 5.

2.4.1 Design Calculation of the Power Transmission System

Overall efficiency of the power unit:

$$\begin{aligned}\eta &= \eta_1^2 \cdot \eta_2 \\ &= 0.98 \times 0.98 \times 0.97 \\ &= 0.93\end{aligned}$$

η_1 —transmission efficiency of a pair of base bearings in a pulley

$$\eta_1 = 0.98;$$

η_2 — transmission efficiency of bevel gears in the changer, $\eta_2 = 0.97$;

Required power of the diesel engine:

$$P_r = \frac{P}{\eta} = \frac{8}{0.93} = 8.6\text{kW}$$

After consulting relevant materials, a ZS195 type diesel engine is selected with a rated power of 8.8 kW and a synchronous speed of 2200 r/min. The output shaft speed of the tractor is 720 r/min.

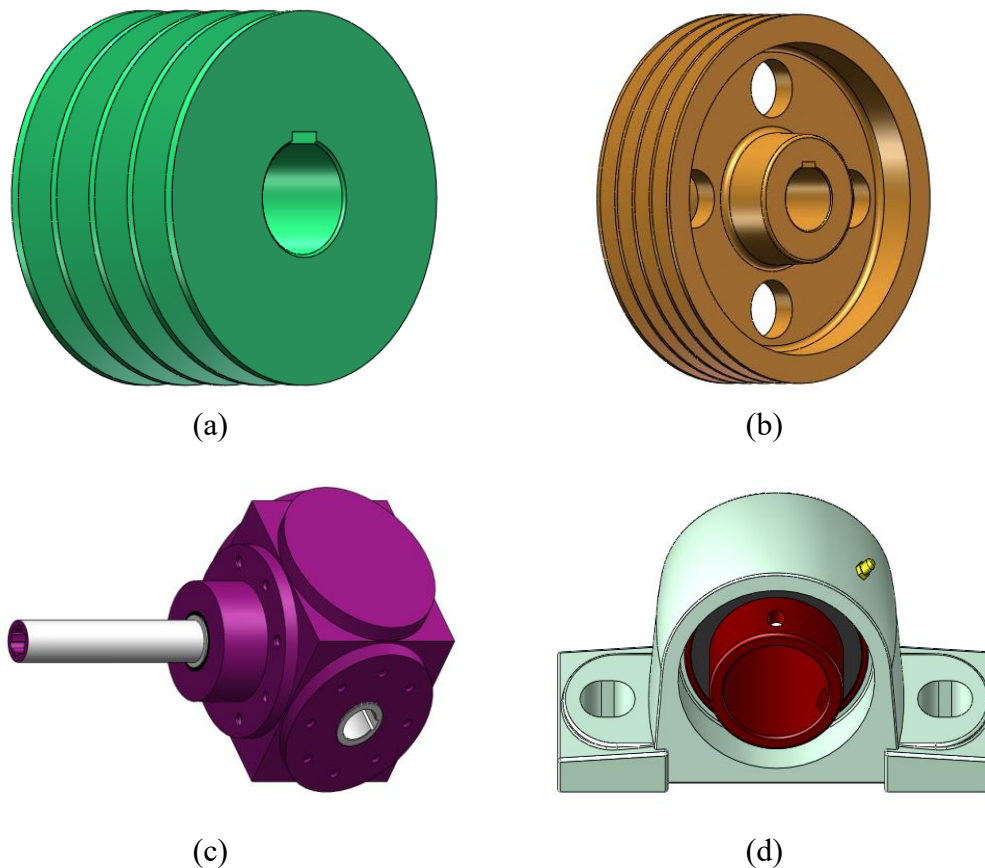

Fig. 5. Components of the Transmission System

(a) Small Pulley (b) Large Pulley (c) Bevel Gear Reverser (d) Pillow Block Bearing with Spherical Outer Surface

2.5 Support System

Fig 6. shows the structural diagram of the designed small whole-stalk sugarcane harvester support system. The bottom of the support system is composed of three lower

transverse beams 1, which are welded together and primarily used for connecting to the tractor and supporting the large pulley; the middle part of the support system mainly consists of four intermediate longitudinal beams 2, which are welded to the lower transverse beams and secured with bolt holes to fix the cutting system and gear changer; the upper part of the support system mainly consists of diagonally placed crossbeams 3, support plates 4, and upper transverse beams 5. The diagonally placed crossbeams 3 are welded between the support plates, and the upper transverse beams are stabilized by the reinforcing effect of auxiliary beams to support the conveying system and fix its position.

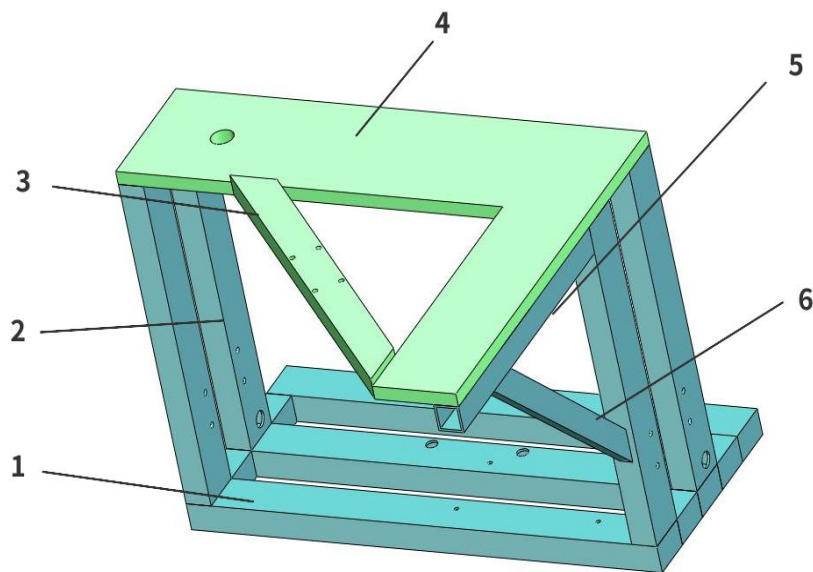

1. Lower transverse beam 2. Intermediate transverse beam 3. Diagonally placed crossbeam 4. Support plate 5. Upper transverse beam 6. Auxiliary beam.

Fig. 6. Support system

The support system supports the entire system structure, mainly composed of welded support frames[11]. According to actual production needs, the support system is mainly installed in front of the tractor for front-wheel drive operation. The two wheels of the tractor drive the movement of the machine, and the wheels are connected to the shaft with a key. The outer end uses a round nut and a round nut with a lock washer for axial positioning[12]. The main function of this system is to ensure the stability of the machine. During harvesting, uneven road surfaces may cause the machine to tilt or tip over, leading to multiple cuts of sugarcane and an increased head breakage rate. Therefore, an effective support system is necessary. The entire system is made of Q235 steel for the frame, and other support structures can be made of welding or sheet metal structures to ensure the stability of the overall structure[13].

2.5.1 Support System Material Selection.

The bracket defines the material as Q235 steel, Q235 steel was selected due to its balanced mechanical strength and good toughness, making it well-suited to withstand the heavy loads and impacts that the harvester may encounter in harsh field environments. At the same time, it retains sufficient ductility to accommodate potential deformation. Moreover, Q235 steel exhibits excellent machinability and weldability, facilitating the fabrication of complex components and accelerating the manufacturing process. Another critical factor in choosing Q235 steel is its cost-effectiveness, which helps control overall production costs, making the harvester more affordable and accessible to individual farmers. As a widely-used material, Q235 steel benefits from a stable supply chain, and its well-established processing and application techniques provide strong technical support for practical production. Additionally, its corrosion and wear resistance ensure the harvester's long-term stability and durability during prolonged outdoor use. The corresponding material performance parameters are shown in Table 1.

Table 1. Material properties

Density /(g.cm ³)	7.85
Elastic modulus /GPa	2.10
Poisson's ratio	0.27
Yield Strength/ Mpa	235

2.5.2 Support System Simulation Preprocessing

First, the support system is meshed, as shown in Fig7, with a mesh size of 20mm, totaling 57,994 nodes and 23,840 elements. Subsequently, boundary conditions are applied. The gravitational force is first applied, with $g = 9.8066 \text{ m/s}^2$. The entire system's bottom and sides are connected with bolts, so it is necessary to add fixed constraints. The top needs to support the conveying system, so a reasonable force F should be added to distribute evenly at this position. As shown in Fig 8.

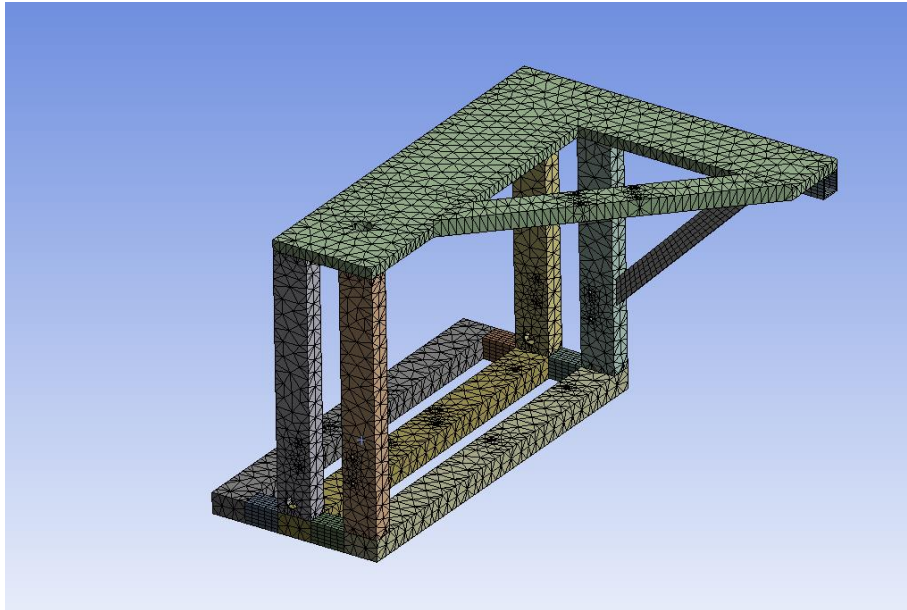

Fig. 7. Meshing of the model

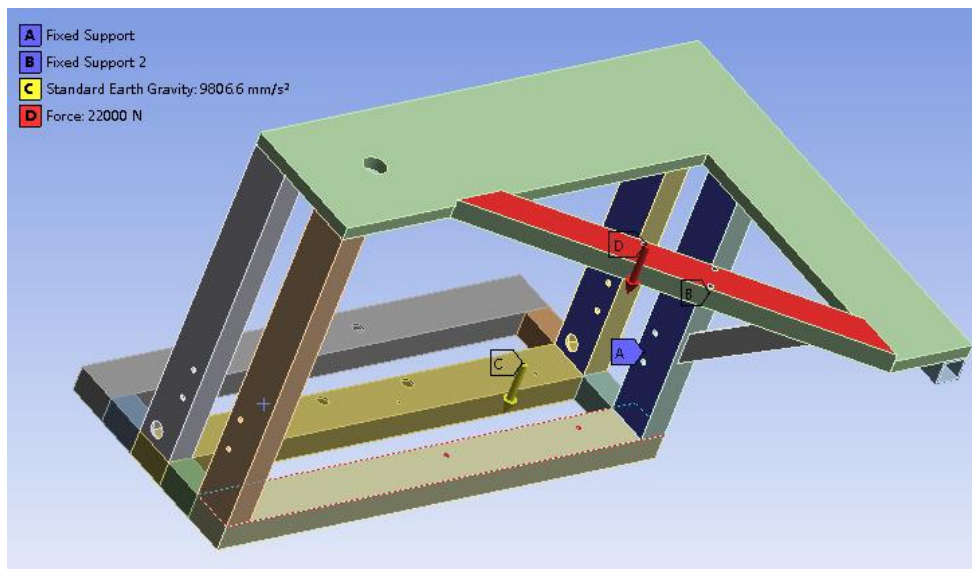

Fig. 8. Applied loads and boundary constraints diagram

2.5.3 Finite Element Analysis Results

After applying loads and setting boundary conditions, finite element analysis can be performed on the support system of the sugarcane harvester, and its total deformation cloud diagram Fig. 9(a) and equivalent stress cloud diagram Fig. 9(b) can be obtained.

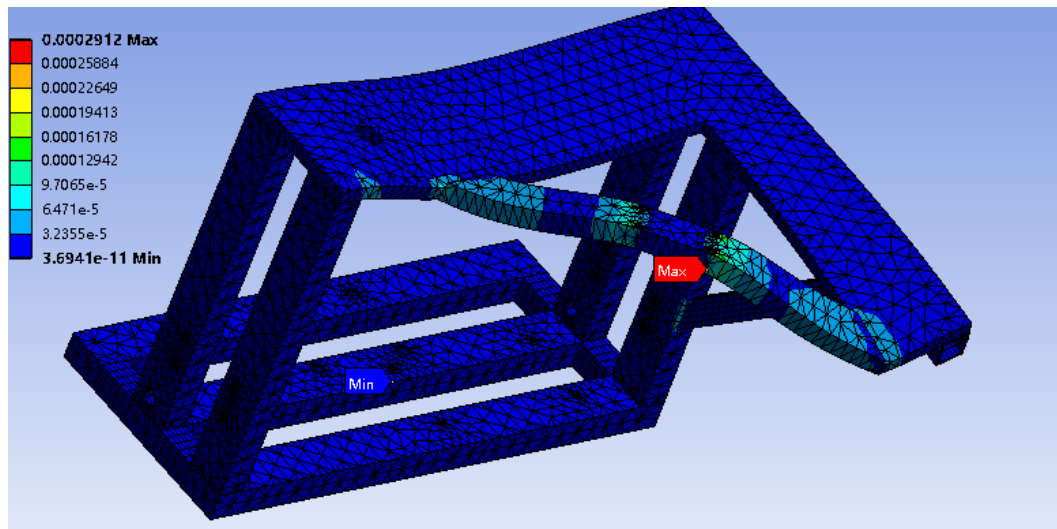

Fig. 9(a) Total deformation cloud diagram

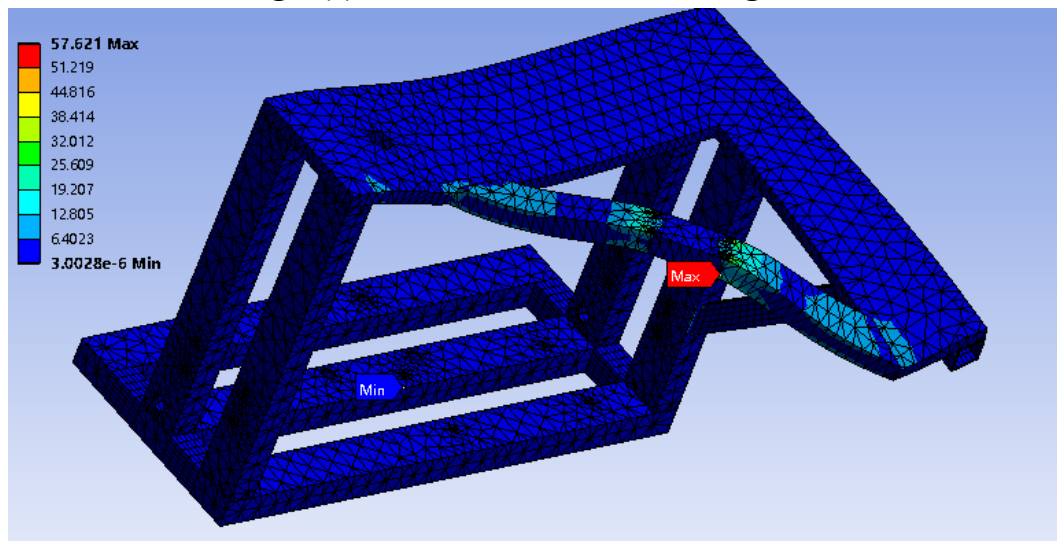

Fig. 9(b) Equivalent stress cloud diagram

According to the figure, it can be seen that the maximum total deformation occurs in the contact area between the bracket top and the conveying system, with a maximum deformation of 0.0002912 mm, and the maximum equivalent stress also occurs at this location, with a magnitude of 57.621 MPa. Since stress concentration mainly exists at geometric discontinuities and the maximum deformation is much less than 1 mm, the model can meet the actual design requirements.

2.6 Overall Structure

As shown in Fig. 10. the designed small whole-stem sugarcane harvester includes four parts: the cutting system, conveying system, power transmission system, and support system.

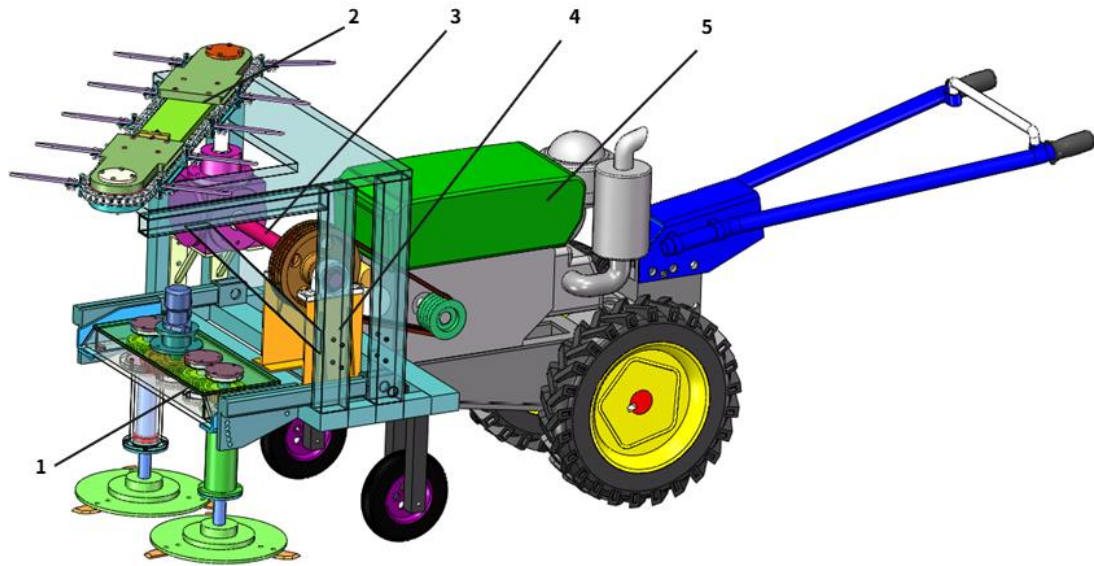

Fig. 10. Schematic Diagram of the Assembly of a Small Whole-Stem Sugarcane Harvester

Table 2. Mechanism parts

1	Sugarcane Cutting System
2	Conveying System
3	Transmission System
4	Support System
5	Walk-behind Tractor

The small whole-stem sugarcane harvester is driven by a hand tractor. The cutting system is connected to the support system in a suspended manner and is installed at the front end of the tractor[14]. The power is provided by the tractor. The power is transmitted to the bevel gear changer via a belt drive. The output shaft of the changer drives the conveying system. The power for the cutting system is provided by a hydraulic motor. The conveying system works synchronously with the cutting system. First, the cutting system cuts the sugarcane root with the rotation of the blade. At the same time, the transmission system drives the conveying device to rotate[15], and the conveying chain and sprocket on the conveying system transport the cut sugarcane to the left rear of the machine.

Table 3. Working Parameters

Working Width	1000mm
Stubble Head Breakage Rate	20%
Operational Speed	0.6m/s
Cutter Disk Speed	700r/min

3. RESULTS AND DISCUSSION

We conducted a theoretical evaluation and discussion on the performance of a small-scale whole-stalk sugarcane harvester. The design expectations are based on a thorough understanding of existing sugarcane harvesting technologies and the application of general principles of agricultural machinery design. The theoretical analysis and discussion of the harvester's performance focus on the following aspects:

1. **Harvesting Efficiency:** Theoretically, mechanizing the harvesting process instead of relying on manual labor can significantly increase the speed of harvesting and the area covered. The harvester aims to enhance overall operational efficiency by optimizing cutting and conveying processes, thereby reducing time losses.
2. **Cane Top Breakage Rate:** The design incorporates optimization of the cutting mechanism to minimize damage to the cane tops. Theoretically, by adjusting the cutting angle and blade design, the breakage rate of cane tops can be reduced, ensuring high-quality harvesting.
3. **Stubble Height Control:** The adjustable cutting platform allows for flexible control of stubble height to meet various agronomic requirements and soil conservation standards.
4. **Ease of Operation:** The design emphasizes human-machine interaction, enabling operators to control the equipment easily and reducing operational difficulty and maintenance workload through thoughtful design.

However, there are certain uncertainties associated with the design of the sugarcane harvester. The following are potential design challenges and areas for improvement:

1. **Adaptability:** The diversity of sugarcane cultivation and the complexity of field conditions require the harvester to have high adaptability. Future research can focus on field tests to evaluate and enhance the machine's adaptability.
2. **Reliability:** Long-term field operations demand high reliability from the machine. Improvements in durability and reliability can be achieved through material selection, structural design, and reinforcement of critical components.
3. **Cost-Effectiveness:** Controlling manufacturing costs while ensuring performance is a critical consideration in the design. Future research can explore optimizing design and adopting cost-effective solutions to enhance the machine's market competitiveness.
4. **User-Friendliness:** Ease of operation and maintenance are crucial for improving user satisfaction. Future studies could further optimize the user

interface and maintenance processes based on user feedback and field testing.

Based on our theoretical evaluation and an in-depth understanding of existing technologies, we have a positive outlook on the performance and potential applications of the small-scale whole-stalk sugarcane harvester. Future work will include building a prototype and conducting tests under actual field conditions to collect necessary performance data and further validate and refine the design[16]. We look forward to providing more efficient, economical, and environmentally friendly solutions for sugarcane harvesting through continuous technological improvements and innovations.

4. CONCLUSION

In response to the demands of sugarcane harvesting, this paper elaborates on the functions, implementation methods, and key technical parameters of a small whole-stalk sugarcane harvester. The harvester is functionally

divided into four systems: cutting, conveying, transmission, and support. The specific structures and corresponding components of each system are identified. Focusing on the support system, which is prone to failure, finite element simulation analysis is conducted, and verification is performed[17].

The whole-stalk sugarcane harvester is designed and refined to enhance the functionality of key operational components such as cutting and conveying collection. This leads to a lighter structure that effectively meets the intelligent and efficient harvesting needs for small plots of dispersed sugarcane cultivation. It facilitates the flow of sugarcane and is more adaptable to the characteristics of sugarcane production, offering greater advantages compared to traditional whole-stalk sugarcane harvesters.

Expanding on this, the design of the small whole-stalk sugarcane harvester takes into account the specific challenges faced during the harvesting process. The cutting system is engineered to efficiently sever the sugarcane stalks with minimal damage, ensuring a high-quality yield. The conveying system is designed to smoothly transport the cut stalks to the collection point, minimizing loss and damage during transit.

The transmission system is crucial for transferring power from the engine to the various operational components, ensuring that the harvester operates at optimal efficiency. It is designed to handle the varying loads and conditions encountered during the harvesting process, providing reliable power delivery.

The support system, as mentioned, is a critical aspect of the harvester's design. It not only provides the structural integrity necessary to withstand the rigors of the field but also ensures the stability and longevity of the machine. Finite element analysis is

used to simulate the stresses and strains experienced by the support system under different operating conditions, allowing for the identification of potential failure points and the implementation of necessary reinforcements.

By focusing on these key areas, the small whole-stalk sugarcane harvester is not only designed to be lightweight and maneuverable but also robust and durable. This balance of features makes it well-suited for the specific demands of small-scale sugarcane farming, where efficiency and adaptability are paramount. The harvester's design also considers the need for ease of maintenance and the use of readily available materials, further enhancing its practicality and cost-effectiveness for farmers.

In summary, the small whole-stalk sugarcane harvester represents a significant advancement in agricultural machinery, offering a solution that is tailored to the unique requirements of sugarcane harvesting. Its innovative design and engineering make it a valuable asset for farmers looking to improve their harvesting operations and increase their productivity.

REFERENCES

- [1] Leidi Di. Design and Research on the Hydraulic System of a Small Cutting-Type Sugarcane Harvester [D]. Chang'an University, 2020.
- [2] Zhang Shengzhong, Zhang Huawei, Tu Weihao, et al. Design and Development of a High-Efficiency Intelligent Sugarcane Harvester with Whole Stem Harvesting [J]. Guangxi Sugar Industry, 2024, 44(03): 174-177.
- [3] Si Lei. Design and Simulation of a Sugarcane Leaf Separation Device for a Small Sugarcane Harvester [D]. Henan University of Science and Technology, 2013.
- [4] Li Lixin. Design and Simulation of the Layout of a Small Hilly Area Sugarcane Combine Harvester and Logistics [D]. Guangxi University, 2008.
- [5] Lv Yong, Yang Jian, Qiao Yanhui. An Overview of the Development of Sugarcane Harvesting Machinery [J]. Southern Agricultural Machinery, 2006 (5): 26-27.
- [6] Yuan Jie. Design and Simulation Analysis of a Reciprocating Sugarcane Harvester [D]. Kunming University of Science and Technology, 2017.
- [7] Xiao Lin. The Development History and Competitive Situation of Sugarcane Harvesting Machinery in China [J]. Agricultural Machinery Quality and Supervision, 2019 (02): 33-34+30.
- [8] Wang Hairui. Design and Experiment of the Floating Control System for the Cutting Disk of Sugarcane Harvester [J]. Southern Agricultural Machinery, 2022, 53(09): 61-64.
- [9] Xie Luxin, Wang Jun, Cheng Shaoming, et al. Simulation Analysis and Experiment of the Leaf Stripping Process for Whole Stem Sugarcane Harvester [J]. Transactions of the Chinese Society of Agricultural Engineering, 2020, 36(18): 56-65.
- [10] Jin Chengqian, Wu Chongyou, Yin Wenqing. Research Progress on Crop Stalk Conveying and Laying Techniques in Mechanized Segmented Harvesting [J]. Agricultural Mechanization Research, 2014, 36(09): 243-247+251.
- [11] Liu Xueliang. Logistics automatic distribution machine [J]. Mechanical Engineer, 2016(2): 102-104.
- [12] Guo Jingchen. Research on the design of peanut kernel crusher based on topological optimization [D]. Tianjin University of Science and Technology, 2020.
- [13] Zhang Jian, Li Ping, Qi Xuemei, et al. Design of car side parking assistant [J]. Mechanical Design, 2019(s2): 86-90.
- [14] Zhang Changxian. The Dawn of Segmented Sugarcane Harvesters [J]. Agricultural Machinery Market, 2017 (02): 30-31.

- [15] Wang Jianpeng. Committed to Becoming a Respected Sugarcane Machine Supplier [N]. China Agricultural Mechanization Guide, 2017-04-17.
- [16] Liu Enchen, Ge Dongyuan, Luo Xinwu. Improved Design and Analysis of a Small-Scale Whole Stem Sugarcane Harvester [J]. Journal of Chinese Agricultural Mechanization, 2018, 39(04): 14-20.
- [17] Xiang Jiawei, Yang Lianfa, Li Shangping. Structural design of root cutter for small sugarcane harvester [J]. Transactions of the Chinese Society of Agricultural Machinery, 2008(04): 56-59.