

Design and Development of a Small Whole-Stem Sugarcane Harvester

ABSTRACT

The small whole-stem sugarcane harvester is a type of sugarcane harvesting machinery designed for individual farmers. It ensures a complete cutting plane during the harvesting process, resulting in low sugarcane head breakage and reduced sugar loss. The sugarcane harvesters currently developed mainly come in two forms: whole-stem and cut-stem. The cut-stem harvesters are larger in size and more expensive, making them unsuitable for the hilly terrain and small-scale cultivation in China. The whole-stem harvesters have poor adjustability of the cutting platform, leading to uneven stubble and high head breakage rates, making it difficult for farmers to choose the right sugarcane harvesting machinery. Therefore, this paper designs a low-cost, rationally structured, easy-to-operate, and individual-farmer-friendly small whole-stem sugarcane harvester that can efficiently complete sugarcane harvesting tasks.

Keywords: Sugarcane harvester; Whole-stem; Structural design; Design and development

1.INTRODUCTION

Sugarcane, known for its high sugar content, is widely cultivated around the world. Thus, the quality and efficiency of the sugarcane industry have become crucial for the healthy development of the sugar industry. Currently, most sugarcane harvesting relies on traditional manual labor, which is labor-intensive and has low efficiency. Statistics show that the overall mechanical usage rate is only 15% during the entire harvesting process, with mechanical usage accounting for about 3% during the actual harvesting phase, which constitutes over 70% of the entire process. The reason is the lack of suitable harvesting machinery. Manual harvesting of sugarcane not only results in unstable cutting quality, long time consumption, and uncertain efficiency but also incurs high labor costs, increasing the economic burden on farmers and reducing their income[1]. Sugarcane harvesting methods are mainly divided into cut-stem and whole-

stem[2]. Large cut-segment sugarcane harvesters have high harvesting efficiency, rich functions, and low head breakage and impurity rates. However, due to the hilly terrain, uneven fields, diverse planting ridge specifications, small-scale cultivation, and individual farming in these areas, large cut-segment sugarcane harvesters cannot be widely applied, and their costs are relatively high compared to other harvesting machinery. Additionally, due to the technical limitations of sugar factories, the production model of sugar factories requires sugarcane to be processed within 16 hours after harvesting, and cut-stem harvesting leads to significant sugar loss.

Therefore, considering the terrain, planting methods, and processing requirements of sugar factories, whole-stem sugarcane harvesters are currently used to complete sugarcane harvesting[3]. However, there are still some shortcomings in the whole-stem sugarcane harvesters that have been developed. For example, poor adjustability of the cutting platform leads to reduced harvesting efficiency; high head breakage rate affects the secondary growth of sugarcane; and the harvested sugarcane contains more impurities, leading to high impurity rates, causing blockages in the conveying device, and resulting in uneven conveying[4]. However, in the future development of sugarcane harvesting mechanization, the development of whole-stem sugarcane harvesters remains the most suitable. From the above analysis, it is evident that the current sugarcane harvesting methods are still relatively backward[5], and there are still significant issues with sugarcane harvesting machinery technology[6]. Under these circumstances, it is necessary to develop small, lightweight, economical, and farmer-friendly sugarcane harvesting machinery that can achieve functions such as cutting, conveying, laying, and collecting, meet the complex and diverse agricultural technical requirements of sugarcane, and provide technical support for improving the efficiency and quality of sugarcane harvesting[7].

2. OVERALL STRUCTURE OF THE SMALL WHOLE-STEM SUGARCANE HARVESTER

2.1 Overall Structure

As shown in Fig.1, the designed small whole-stem sugarcane harvester includes four parts: the cutting system, conveying system, power transmission system, and support system.

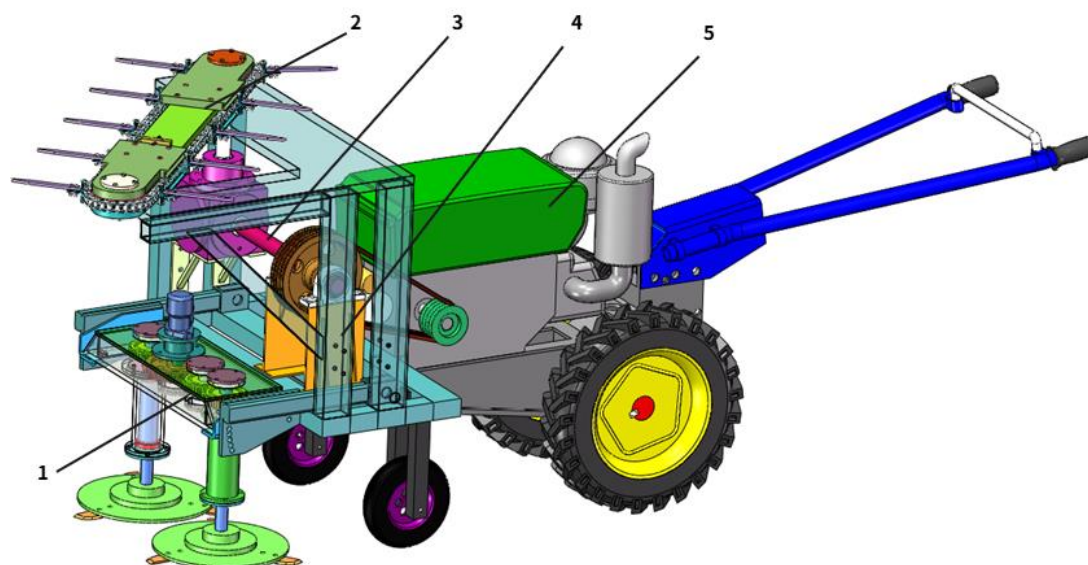

Fig.1. Schematic Diagram of the Assembly of a Small Whole-Stem Sugarcane Harvester

Table 1. Mechanism parts

1	Sugarcane Cutting System
2	Conveying System
3	Transmission System
4	Support System
5	Walk-behind Tractor

2.2 Working Process

The small whole-stem sugarcane harvester is driven by a hand tractor. The cutting system is connected to the support system in a suspended manner and is installed at the front end of the tractor[8]. The power is provided by the tractor. The power is transmitted to the bevel gear changer via a belt drive. The output shaft of the changer drives the conveying system. The power for the cutting system is provided by a hydraulic motor. The conveying system works synchronously with the cutting system. First, the cutting system cuts the sugarcane root with the rotation of the blade. At the same time, the transmission system drives the conveying device to rotate[9], and the conveying chain and sprocket on the conveying system transport the cut sugarcane to the left rear of the machine.

Table 2. Working Parameters

Working Width	1000mm
Stubble Head Breakage Rate	20%
Operational Speed	0.6m/s
Cutter Disk Speed	700r/min

3. KEY SYSTEM DESIGN AND DEVELOPMENT

3.1 Sugarcane Cutting System

As shown in Fig.2, this is the structural diagram of the cutting system for the designed small whole-stem sugarcane harvester. The hydraulic motor 6 is fixed together with the motor flange 5. The output shaft of the hydraulic motor is connected to the main shaft of the gear transmission group via an internal spline key. The rotation of the main shaft drives the gear to rotate 7, and the two are connected by a key. The gear transmission enables both knife shafts 3 to rotate in opposite directions at the same speed. The sleeve 10 is fixed to the bottom of the gearbox 4 with bolts. The exterior of the knife shaft 3 is equipped with two tapered roller bearings, which are fixed by the embedded end covers and the sleeve 10 at both ends. The knife shaft 3 is connected to the disc 2 through a taper fit, and the disc 2 is driven to rotate by adjusting the axial displacement of the knife shaft 3 with a nut to achieve an interference fit. The multi-blade knife 1 is connected to the disc 2 with bolts, which facilitates installation and replacement.

This paper selects a disc cutter for sugarcane harvesting operations, considering the use of a double-disc cutter to reduce inertial vibration. The cutting system mainly consists of a gear box, two cutting blades, discs, a cutter shaft, and a support frame. The power transmission mainly relies on the hydraulic system to drive the rotation of the hydraulic motor's transmission shaft, enabling the straight gears inside the gear box to transmit power. The cutter shaft rotates through the gears on both sides, and the cutter shaft is connected to the disc, thus achieving the harvesting of sugarcane. The upper end of the cutter shaft is connected to the gear with a key, and the lower end has threads, which are fixed to the disc with a nut[10]. The blade is fixed to the disc with bolts, and four blades are installed at the bottom end of the disc, with the blades of the left and right discs set in an alternating manner. When the sugarcane harvester is in motion, if the blade is damaged by cutting a stone, it can quickly select, correct, or replace different types of blades to ensure cutting efficiency and a lower head breakage rate[11].

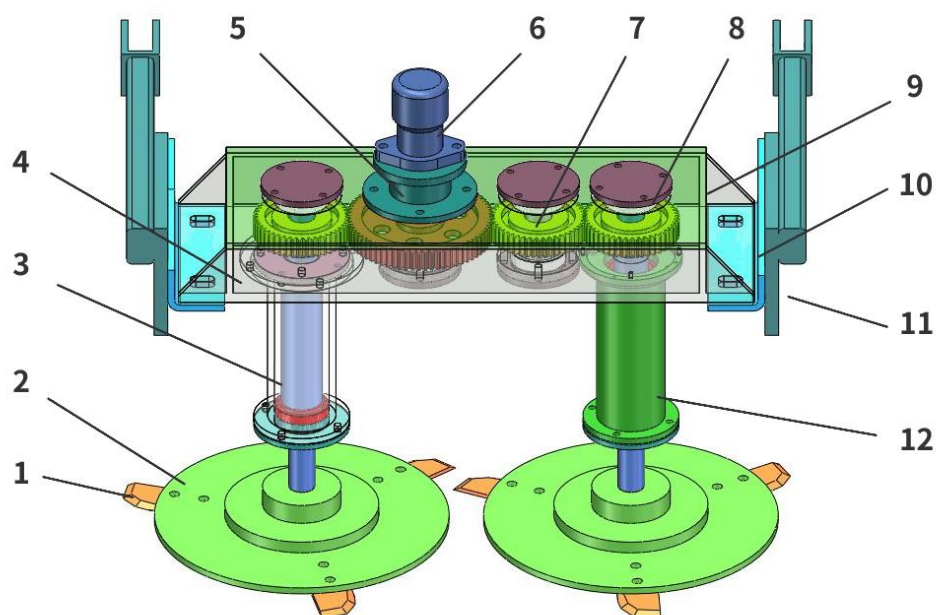

Fig. 2. Sugarcane Cutting System

3.2 Conveying System

The structure diagram of the conveying system for the small whole-stem sugarcane harvester is shown in Fig. 3. The conveying system is mainly composed of five parts: the conveying chain, the actuating device, the drive shaft, the tensioning device, and the support device. The conveying chain includes the chain 7, the drive sprocket 9, and the idler sprocket 3. The design involves adding some auxiliary holes on the chain, and the connection between the actuating device 1 and the chain is completed with bolts. The tension of the sprockets is adjusted by changing the position of the adjustment screw 6, which alters the center distance of the conveying chain, and is equipped with self-aligning roller bearings 9 to ensure the normal operation of the drive shaft. The connecting frame 7 is fixed to the top cover 5 with bolts. The drive shaft drives the sprocket to rotate via a key, enabling the actuating device on the chain to complete a circular motion, thereby moving the cut sugarcane to the left rear of the cutter, fulfilling the conveying and laying functions for the sugarcane.

Considering that the sugarcane harvester requires a simple structure and low cost, the conveying system is proposed to use a chain-tooth type for sugarcane transportation. This conveying system includes components such as sprockets, chains, and sprocket teeth. The sprocket is mounted on the upper end of the support system through a transmission shaft. Through the rotation of the transmission shaft, the sprocket drives

the chain to rotate. The sprocket teeth are evenly distributed on the outer surface of the chain, and the teeth can separate the sugarcane from the cutting system and complete the transportation. The conveying system has a certain distance from the cutting system in the horizontal direction to ensure that the sugarcane can be normally moved after cutting. During the laying process, it mainly relies on the installation of an arc-shaped baffle at the end of the chain. When the sugarcane is transported to the baffle, it can change the direction of the sugarcane's movement and achieve transverse laying of sugarcane.

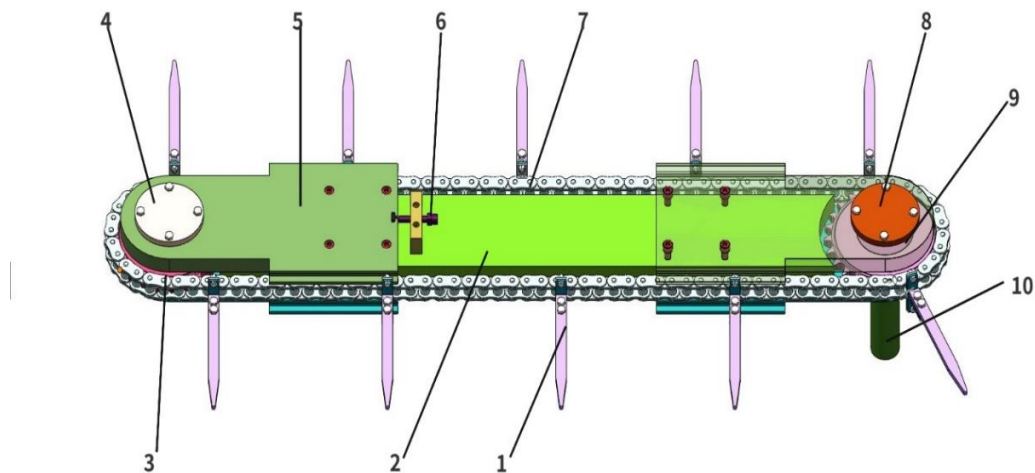

Fig. 3. Conveying System

3.2.1 Design of the Actuating Device

As shown in Fig 4, it is the structural diagram of the actuating device. The actuating device consists of two parts, specifically including the actuating teeth and the plate reinforcement. The total length of the actuating teeth is 225mm, and the width is 18.5mm. The installation height of the actuating teeth is in the middle-upper part of the sugarcane, and the shape of the actuating teeth adopts a long-tooth structure, which can more stably complete the actuation of the sugarcane and transport it. The actuating teeth are connected to the plate reinforcement with two bolts of diameter M8, and the material of the actuating teeth is selected as HT150.

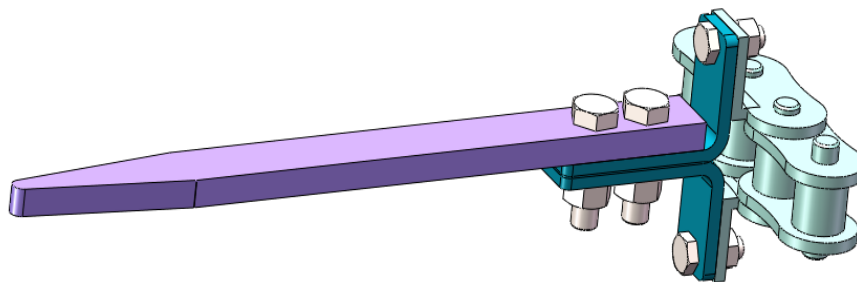

Fig .4 .Actuating device

A part of the chain protrudes outward, welded together with the chain, and there is a bolt hole with a diameter of M6, which facilitates connection with the plate reinforcement. The shape of the plate reinforcement is designed as an L-shape, with the purpose of connecting the actuating teeth with the chain, and the material of the plate reinforcement is Q235.

3.3 Transmission System

The diesel engine of the tractor provides power, which is transmitted to the transmission system via a belt. The power is then transmitted to the cutting and conveying systems. The transmission system mainly includes belts, pulleys, and bevel gear changers. Based on the designed specifications and dimensions of the cutting and conveying systems and the maximum load, the required power is calculated, and an appropriate transmission ratio is selected. Belt transmission operates with low noise, has elastic buffering, and shock absorption, making the movement process more stable. It does not require high manufacturing and installation standards, and does not need lubrication during operation. When the work encounters overload, the belt will slip on the pulley, providing a certain level of protection[12].

3.3.1 Design Calculation of the Power Transmission System

Overall efficiency of the power unit:

$$\begin{aligned}\eta &= \eta_1^2 \cdot \eta_2 \\ &= 0.98 \times 0.98 \times 0.97 \\ &= 0.93\end{aligned}$$

η_1 —*transmission efficiency of a pair of base bearings in a pulley* ,

$$\eta_1 = 0.98 ;$$

η_2 — *transmission efficiency of bevel gears in the changer* , $\eta_2 = 0.97 ;$

Required power of the diesel engine:

$$P_r = \frac{P}{\eta} = \frac{8}{0.93} = 8.6\text{kW}$$

After consulting relevant materials, a ZS195 type diesel engine is selected with a rated power of 8.8 kW and a synchronous speed of 2200 r/min. The output shaft speed of the tractor is 720 r/min.

3.4 Support System

Fig 5. shows the structural diagram of the designed small whole-stalk sugarcane harvester support system. The bottom of the support system is composed of three lower transverse beams 1, which are welded together and primarily used for connecting to the tractor and supporting the large pulley; the middle part of the support system mainly consists of four intermediate longitudinal beams 2, which are welded to the lower transverse beams and secured with bolt holes to fix the cutting system and gear changer; the upper part of the support system mainly consists of diagonally placed crossbeams 3, support plates 4, and upper transverse beams 5. The diagonally placed crossbeams 3 are welded between the support plates, and the upper transverse beams are stabilized by the reinforcing effect of auxiliary beams to support the conveying system and fix its position.

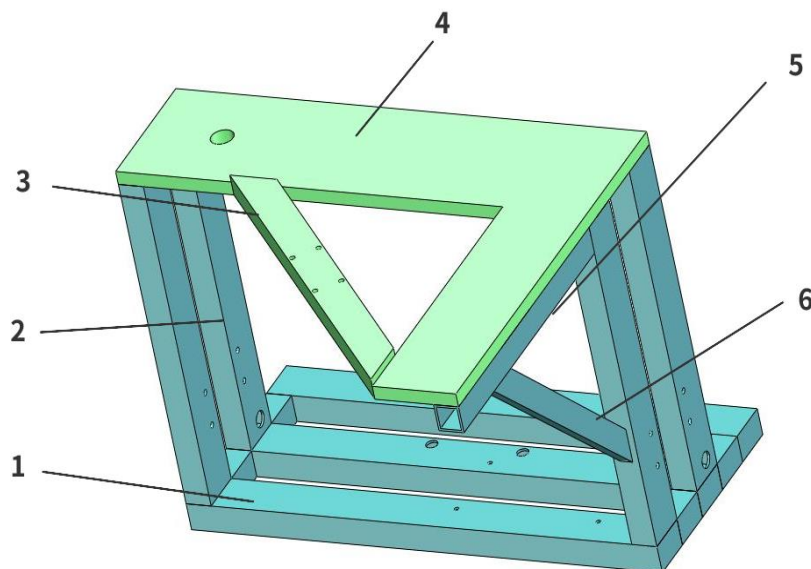

Fig .5. Support system

The support system supports the entire system structure, mainly composed of welded support frames[13]. According to actual production needs, the support system is mainly installed in front of the tractor for front-wheel drive operation. The two wheels of the tractor drive the movement of the machine, and the wheels are connected to the shaft with a key. The outer end uses a round nut and a round nut with a lock washer for axial positioning[14]. The main function of this system is to ensure the stability of the machine. During harvesting, uneven road surfaces may cause the machine to tilt or tip over, leading to multiple cuts of sugarcane and an increased head breakage rate. Therefore, an effective support system is necessary. The entire system is made of gray cast iron for the frame, and other support structures can be made of welding or sheet metal structures to ensure the stability of the overall structure[15].

3.4.1 Support System Material Selection.

the bracket defines the material as Q235 steel, and the corresponding material performance parameters are shown in Table 3.

Table 3. Material properties

Density /(g.cm ³)	7.85
Elastic modulus /GPa	2.10
Poisson's ratio	0.27
Yield Strength/ Mpa	235

3.4.2 Support System Simulation Preprocessing

First, the support system is meshed, as shown in Fig5, with a mesh size of 20mm, totaling 57,994 nodes and 23,840 elements. Subsequently, boundary conditions are applied. The gravitational force is first applied, with $g = 9.8066 \text{ m/s}^2$. The entire system's bottom and sides are connected with bolts, so it is necessary to add fixed constraints. The top needs to support the conveying system, so a reasonable force F should be added to distribute evenly at this position. As shown in Fig 6.

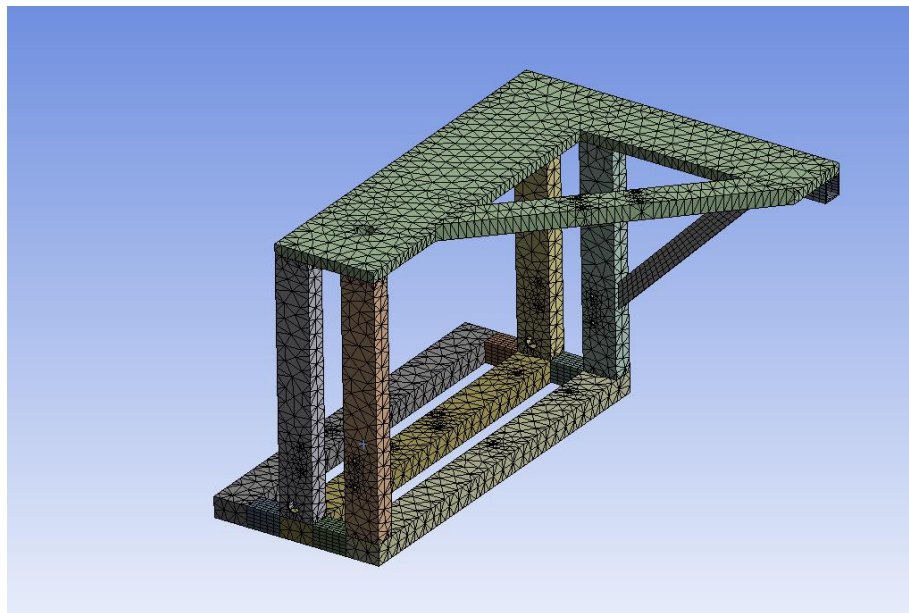

Fig .6.Meshing of the model

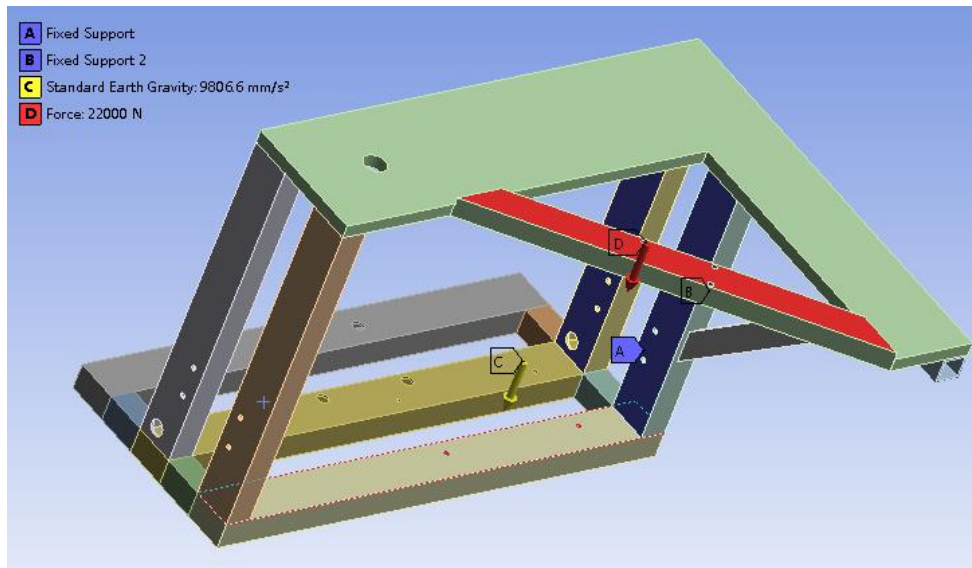

Fig.6. Applied loads and boundary constraints diagram

3.4.3 Finite Element Analysis Results

After applying loads and setting boundary conditions, finite element analysis can be performed on the support system of the sugarcane harvester, and its total deformation cloud diagram Fig. 7(a) and equivalent stress cloud diagram Fig. 7(b) can be obtained.

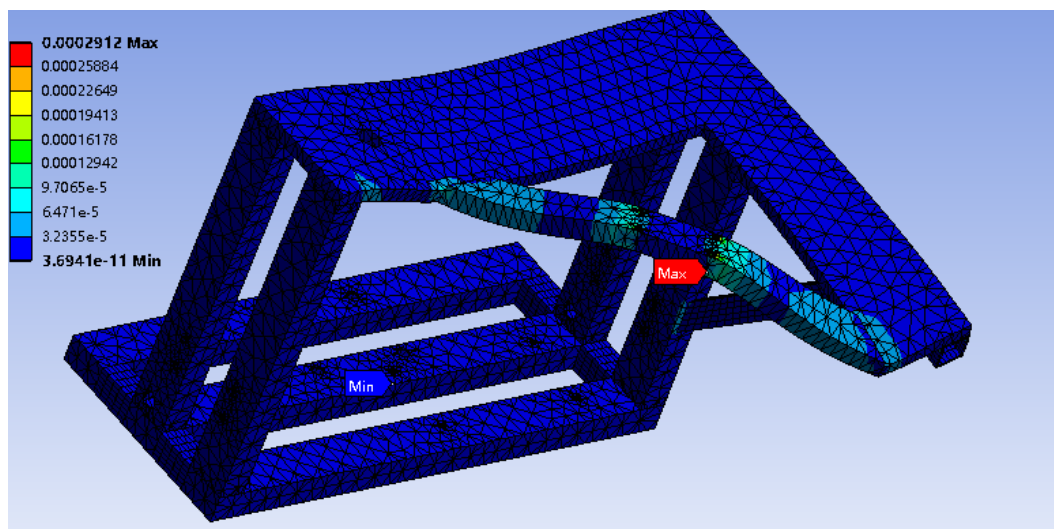

Fig. 7(a) Total deformation cloud diagram

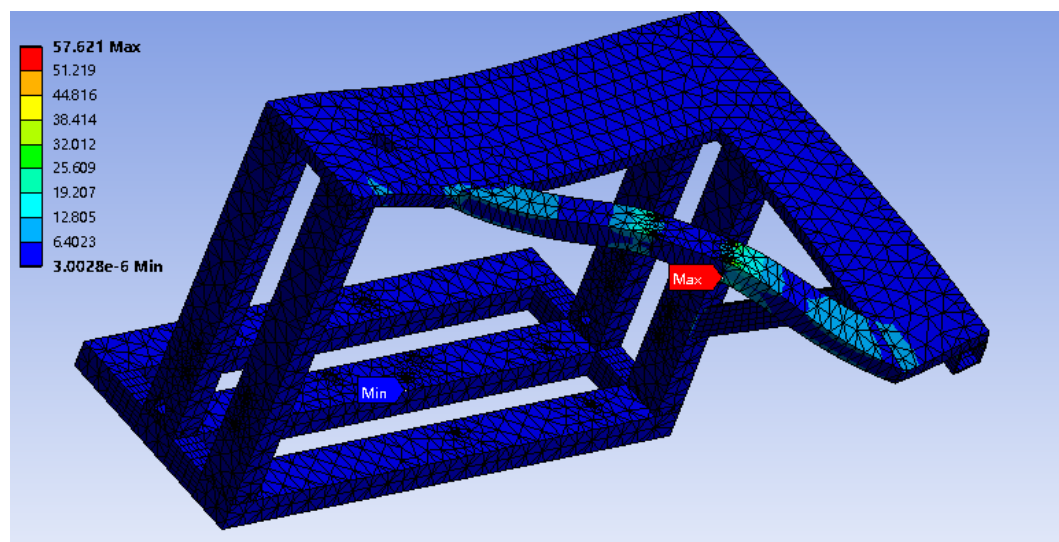

Fig. 7(b) Equivalent stress cloud diagram

According to the figure, it can be seen that the maximum total deformation occurs in the contact area between the bracket top and the conveying system, with a maximum deformation of 0.0002912 mm, and the maximum equivalent stress also occurs at this location, with a magnitude of 57.621 MPa. Since stress concentration mainly exists at geometric discontinuities and the maximum deformation is much less than 1 mm, the model can meet the actual design requirements.

4. CONCLUSION

In response to the demands of sugarcane harvesting, this paper elaborates on the functions, implementation methods, and key technical parameters of a small whole-stalk sugarcane harvester. The harvester is functionally divided into four systems: cutting, conveying, transmission, and support. The specific structures and corresponding components of each system are identified. Focusing on the support system, which is prone to failure, finite element simulation analysis is conducted, and verification is performed[16].

The whole-stalk sugarcane harvester is designed and refined to enhance the functionality of key operational components such as cutting and conveying collection. This leads to a lighter structure that effectively meets the intelligent and efficient harvesting needs for small plots of dispersed sugarcane cultivation. It facilitates the flow of sugarcane and is more adaptable to the characteristics of sugarcane production, offering greater advantages compared to traditional whole-stalk sugarcane harvesters.

Expanding on this, the design of the small whole-stalk sugarcane harvester takes into account the specific challenges faced during the harvesting process. The cutting system is engineered to efficiently sever the sugarcane stalks with minimal damage,

ensuring a high-quality yield. The conveying system is designed to smoothly transport the cut stalks to the collection point, minimizing loss and damage during transit.

The transmission system is crucial for transferring power from the engine to the various operational components, ensuring that the harvester operates at optimal efficiency. It is designed to handle the varying loads and conditions encountered during the harvesting process, providing reliable power delivery.

The support system, as mentioned, is a critical aspect of the harvester's design. It not only provides the structural integrity necessary to withstand the rigors of the field but also ensures the stability and longevity of the machine. Finite element analysis is used to simulate the stresses and strains experienced by the support system under different operating conditions, allowing for the identification of potential failure points and the implementation of necessary reinforcements.

By focusing on these key areas, the small whole-stalk sugarcane harvester is not only designed to be lightweight and maneuverable but also robust and durable. This balance of features makes it well-suited for the specific demands of small-scale sugarcane farming, where efficiency and adaptability are paramount. The harvester's design also considers the need for ease of maintenance and the use of readily available materials, further enhancing its practicality and cost-effectiveness for farmers.

In summary, the small whole-stalk sugarcane harvester represents a significant advancement in agricultural machinery, offering a solution that is tailored to the unique requirements of sugarcane harvesting. Its innovative design and engineering make it a valuable asset for farmers looking to improve their harvesting operations and increase their productivity.

REFERENCES

- 1 Leidi Di. Design and Research on the Hydraulic System of a Small Cutting-Type Sugarcane Harvester [D]. Chang'an University, 2020.
- 2 Xiao Ling. Application of Two Types of Sugarcane Harvesters in Sugarcane Harvesting [J]. Sugarcane Sugar Industry, 2012, (03): 56-60.
- 3 Si Lei. Design and Simulation of a Sugarcane Leaf Separation Device for a Small Sugarcane Harvester [D]. Henan University of Science and Technology, 2013.
- 4 Li Lixin. Design and Simulation of the Layout of a Small Hilly Area Sugarcane Combine Harvester and Logistics [D]. Guangxi University, 2008.
- 5 Lv Yong, Yang Jian, Qiao Yanhui. An Overview of the Development of Sugarcane Harvesting Machinery [J]. Southern Agricultural Machinery, 2006 (5): 26-27.
- 6 Yuan Jie. Design and Simulation Analysis of a Reciprocating Sugarcane Harvester [D]. Kunming University of Science and Technology, 2017.
- 7 Xiao Lin. The Development History and Competitive Situation of Sugarcane Harvesting Machinery in China [J]. Agricultural Machinery Quality and Supervision, 2019 (02): 33-34+30.
- 8 Zhang Changxian. The Dawn of Segmented Sugarcane Harvesters [J]. Agricultural Machinery Market, 2017 (02): 30-31.
- 9 Wang Jianpeng. Committed to Becoming a Respected Sugarcane Machine Supplier [N]. China Agricultural Mechanization Guide, 2017-04-17.
- 10 Li Shangping, Deng Jinlian, Meng Yanmei, et al. Considerations on the Development of Sugarcane Harvesting Machinery in Hilly Areas [C]. Proceedings of the National Sugarcane Production Mechanization and Industry Seminar and Sugarcane Production Mechanization Field Demonstration. 2002.
- 11 Li Peng. Virtual Design of the Cutting Device for Sugarcane Harvesters [D]. Henan University of Science and Technology, 2013.
- 12 Jin Chengqian, Wu Chongyou, Yin Wenqing. Research Progress on Crop Stalk Conveying and Laying Techniques in Mechanized Segmented Harvesting [J]. Agricultural Mechanization Research, 2014, 36(09): 243-247+251.
- 13 Liu Xueliang. Logistics automatic distribution machine [J]. Mechanical Engineer, 2016(2): 102-104.
- 14 Guo Jingchen. Research on the design of peanut kernel crusher based on topological optimization [D]. Tianjin University of Science and Technology, 2020.
- 15 Zhang Jian, Li Ping, Qi Xuemei, et al. Design of car side parking assistant [J]. Mechanical Design, 2019(s2): 86-90.

- 16 Xiang Jiawei, Yang Lianfa, Li Shangping. Structural design of root cutter for small sugarcane harvester [J]. Transactions of the Chinese Society of Agricultural Machinery, 2008(04): 56-59.