

DEVELOPMENT OF THE CONTROL SYSTEM OF THE LEVEL WITH CONTROLLER

Abstract. The purpose of the study is to control the level of water in reservoirs. For this, the importance of ensuring the optimal operation of pumps, electric drawers, control panels, and communication devices is justified. Innovations obtained as a result of research:

The proposed Control system has the ability to work in 3 modes: direct local control (classical model), manual control by means of a computer (control is performed from a center, but the operator controls the entire process) and automatic control.

Organization of the optimal operation of the devices: by ensuring the alternating operation of artesian pumps and pumps pumping water from the intermediate reservoir to the main reservoir, the longevity of the devices was ensured

Comfortable management: If the operators had to monitor the system by covering an average distance of 3-4 km during the day, now they have achieved more comfortable and at the same time more reliable management with a single central control.

Savings: if before the system was installed, water was discharged to the evacuation line with a certain intensity, now water losses have been prevented by means of more flexible management.

Keywords: local control, water level, level sensor, level transmitter, ultrasonic sensor.

INTRODUCTION

The sequence of construction of SCADA systems, identification and elimination of conflicts, provision of convenient management to operators was possible on the basis of scientific innovation. The ability to communicate with machine learning systems is one of the most relevant and understudied areas of these systems. Since the knowledge obtained through the SCADA system is collected in the center as a database, it allows operations on that data. Due to repeated processes, stochastic approximation of other parameters is also possible based on the dependence of one parameter on another parameter.

Automation of technical processes refers to a set of tools and methods for the implementation of various systems without the participation of individuals. The level of existing technologies and the speed of progress have reached such a point that it is no longer possible to do successful work without a significant modernization of the technological base and the introduction of computer technology. Today, the technical basis of the development of industry and various areas of production is the automation of production processes.

The automation of production processes undoubtedly leads to an improvement in the overall labor productivity of the company, an increase in the quality of the product and an increase in the safety of the workplace. The last decade has seen a shift from analog control systems to digital control systems, which provide higher accuracy and more data processing, storage and transmission options [1, 2]. Continuous technological processes in most companies require continuous automated control of the amount of product, raw material or liquid in the tank. Level measurement systems are designed to control the level of various environments in product storage tanks during production processes in industrial companies, as well as to maintain a constant level of liquids in tanks, to prevent leakage and overflowing.

In every industry, the product level in the production tanks must be precisely controlled to meet the requirements of the entire technical process.

The use of level measuring devices allows you to control not only the level, but also the properties of the measured product (level, density and pressure). The biggest way to improve production efficiency is to use automated control systems [3-5].

RESEARCH METHODOLOGY

When the research was conducted, it was not based on the logic of a two-step view of the system. The hardware and software were studied separately, the pros and cons of the selected versions were examined, and the most economically suitable options were selected. The practical importance of the aforementioned work is the establishment of a system that provides uninterrupted communal needs for residential areas. The research conducted is not only in the software environment but also verified in practice, delivered and currently working.

RESEARCH OF MICROCONTROLLERS AND SELECTION OF SUITABLE MICROCONTROLLER

Microcontrollers have become an essential part of electronic devices, from household appliances to complex industrial machines. With technological advances, microcontrollers have become more powerful, sophisticated, and versatile, making them ideal for a wide range of applications. When researching microcontrollers, several factors come into play. One of the most critical factors is the processing power of the microcontroller [6]. This determines the speed at which the microcontroller can perform tasks and the complexity of those tasks. Other factors to consider include the amount of memory available, the number of input/output pins, and the ease of programming. It is also essential to consider the specific needs of the project. Different microcontrollers have different features and capabilities, and selecting the right one can make a significant difference in the success of the project.

A microcontroller is a sort of microcircuit that is used to operate electrical devices. A typical microcontroller contains randomly accessible memory and read-only memory, as well as containing both CPU and peripheral device functions. In general, a microcontroller is a single-chip computer and can perform fairly simple tasks. Computers, consumer electronics, and industrial applications all use microcontrollers [7-10]. Variety of designs are used to build microcontrollers. Harvard, Princeton and companies such as CISC (Complete Instruction Set Computers), RISC (Reduced Instruction Set Computers) are examples [11]. RISC and CISC processors differ from each other because CISCs have smaller packet instructions and therefore more advanced addressing capabilities. In this case, the developer has to mix the instructions to perform more complex tasks.

A typical microcontroller consists of a central processing unit (CPU), memory, input/output (I/O) ports, and various peripheral devices. The CPU is responsible for executing instructions and controlling the overall operation of the microcontroller. The memory is used to store data and program instructions. The I/O ports allow the microcontroller to communicate with other devices, such as sensors and actuators. Microcontrollers are typically programmed using a specialized language, such as C or assembly language. The code is written on a personal computer and then transferred to the microcontroller using a programmer. Once the code is loaded onto the microcontroller, it will execute the instructions and perform the desired function. Microcontrollers are used in a variety of applications, including robotics, automotive systems, and industrial automation. They are often used to control motors,

sensors, and other devices. For example, a microcontroller might be used to control the speed of a motor in a robot or to monitor the level of a machine in an industrial setting. Some microcontrollers, especially 16- and 32-bit microcontrollers, rely on external memory containing both program memory (ROM) and some data memory (RAM) required for a particular application (figure 1).

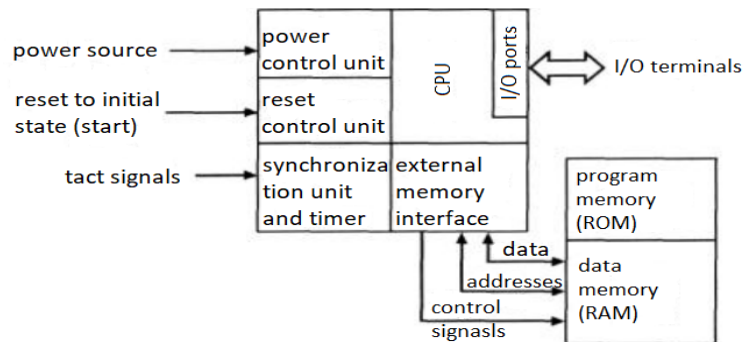

Figure 1. Block diagram of a microcontroller with external memory

Microcontrollers can also have external memory, which can be used to store additional data or program instructions. This allows for more complex programs to be executed on the microcontroller. However, using external memory can add cost and complexity to the design. In addition to the benefits of internal memory, external memory can also provide more flexibility and storage capacity. This is particularly useful for applications that require large amounts of data to be stored or processed. For example, in a data acquisition system, external memory can be used to store large amounts of sensor data. There are several types of external memory that can be used with microcontrollers, including static random access memory (SRAM), dynamic random access memory (DRAM), and flash memory. The choice of memory type will depend on the specific requirements of the application. SRAM is a type of memory that is fast and efficient, but it requires constant power to maintain the stored data. DRAM is similar to SRAM, but it is slower and less efficient, and it requires periodic refreshing to maintain the stored data. Flash memory is a type of non-volatile memory that is commonly used for storing program code and data [18]. When using external memory with a microcontroller, it is important to consider factors such as access time, power consumption, and compatibility with the microcontroller. Some microcontrollers have specific requirements for the type and configuration of external memory that can be used. In summary, external memory can be a useful addition to a microcontroller-based system, providing increased flexibility and storage capacity. However, it is important to carefully consider the specific requirements of the application when choosing a type of external memory to use [7].

The number of GPRs in a microcontroller can vary depending on the specific architecture. Some microcontrollers have only a few GPRs, while others can have several dozen. The number of GPRs can affect the performance of the microcontroller, as more GPRs can allow for faster data manipulation.

In addition to GPRs, microcontrollers can also have special-purpose registers (SPRs) that are used for specific functions, such as controlling the operation of peripherals or managing

interrupts. SPRs are typically located outside of the CPU and are accessed using special instructions.

When programming a microcontroller, it is important to carefully manage the use of GPRs and SPRs. Efficient use of registers can help to optimize the performance of the microcontroller and reduce the amount of memory required for program code and data.

In summary, GPRs are an essential component of microcontroller architecture, providing fast and efficient data manipulation. The number of GPRs can affect the performance of the microcontroller, and the use of SPRs should also be carefully managed when programming the microcontroller [9]. According to the order of the names, flash, RAM, and EEPROM are memory types that store program code, temporary working data, and long-term data that are independent of the microcontroller's power source [12]. The program determines the tasks and modes of operation, but the activities are carried out in hardware, that is, together with the main program.

1. 8-bit AVR.

2. AVR is 32 bit.

3. AVR xMega chip

The 8-bit microcontroller family has been the most popular for the past decade. First, there are two popular families known as AVR 8-bit microcontrollers:

- ATTINY—Often there are eight pins or more. Memory functions and sizes are usually smaller than the following;
- ATMEGA are more advanced microcontrollers with larger memory, pins and various functional units;

The most powerful subfamily of microcontrollers, xMega is sold in packages with multiple pins from 44 to 100. This is necessary for projects with a large number of sensors and actuators. In addition, it delivers outstanding performance thanks to improved memory space and processing speed. AVR microcontrollers are easy to use, use little energy and provide a high level of integration. These microcontrollers can be used in a wide variety of devices such as public systems, public address systems, LCD displays, and boards with limited space. They are also used in a variety of applications such as authentication, automobile electronics, measuring battery levels, and preventing short circuits and overheating. Selecting the most suitable microcontroller for a project requires careful research and consideration of various factors, including processing power, memory capacity, input/output pins, and ease of programming. By selecting the right microcontroller, a project can be completed more efficiently and effectively, leading to greater success. In conclusion, during the research phase, it is essential to identify the specific needs of the project, including the required processing power, memory capacity, and input/output pins. Once these needs are established, it is important to research the various microcontrollers available on the market and compare their features, capabilities, and ease of programming. It is important to take the time to conduct thorough research and select the right microcontroller for the job. With the right microcontroller, a project can be completed more efficiently and effectively, leading to greater success. In summary, microcontrollers are critical components of electronic devices, and selecting the right microcontroller for a project requires careful research and consideration of several factors. A thorough understanding of these factors can help engineers and developers choose the most suitable microcontroller for their project, leading to greater success and efficiency.

CONTROL PANELS FOR CONSTANT LEVEL MAINTENANCE

Central to the hardware is control panels aimed at keeping the level stable in the warehouse. The control panel is connected to all the devices of the system, providing them with energy and controlling them. Control panels are placed in panel frames of different materials, taking into account the environmental conditions. Figure 2, Figure 3, a part of the electrical scheme of the control panel placed in the drawer room is shown. It is imperative to note that when designing schemes, the engineer must be able to maintain the neatness, adequacy and constructability of the schemes.

In order to determine the absence of power in the panel or the loss of one of the phases, the HI1, HI2, HI3 phase indicators are connected to the L1, L2, L3 buses with a three-pole F1 machine, respectively [29]. In order to separate the control part of the system from the power part, the isolation transformer T1 is connected by means of a bipolar F3 automaton.

We take one of the outputs of the transformer as N and the other as L. S1-"emergency stop" button controls relay R1. Controls the sequence and completeness of the phases with the PR1-phase protection relay. If the sequence of phases is maintained and all phases are present, contacts 21 and 24 of the PR1 relay are closed. If the relays R1 and PR1 give the "OK" signal, the contactor KM1 closes and the voltage is transferred to the motor control circuit (MCC).

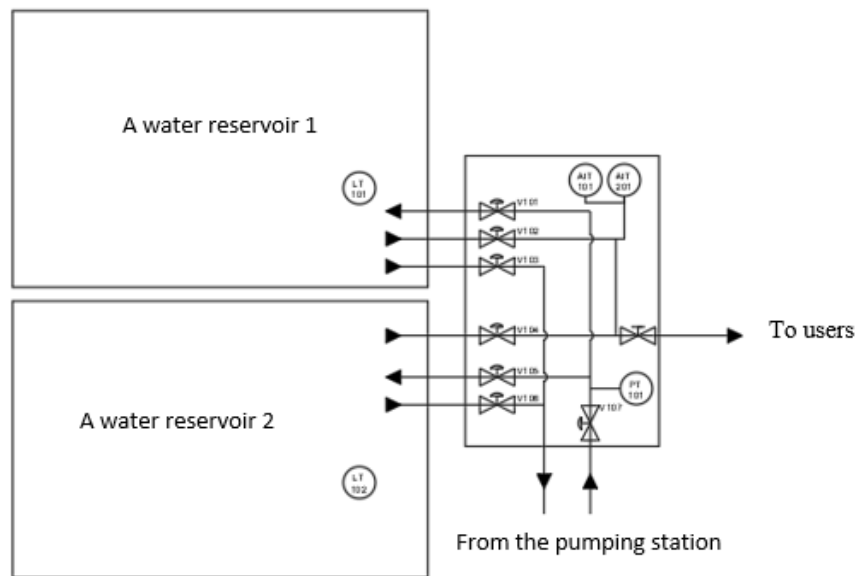

Figure 2. The scheme of entering and distributing water from the pumping station to the reservoirs

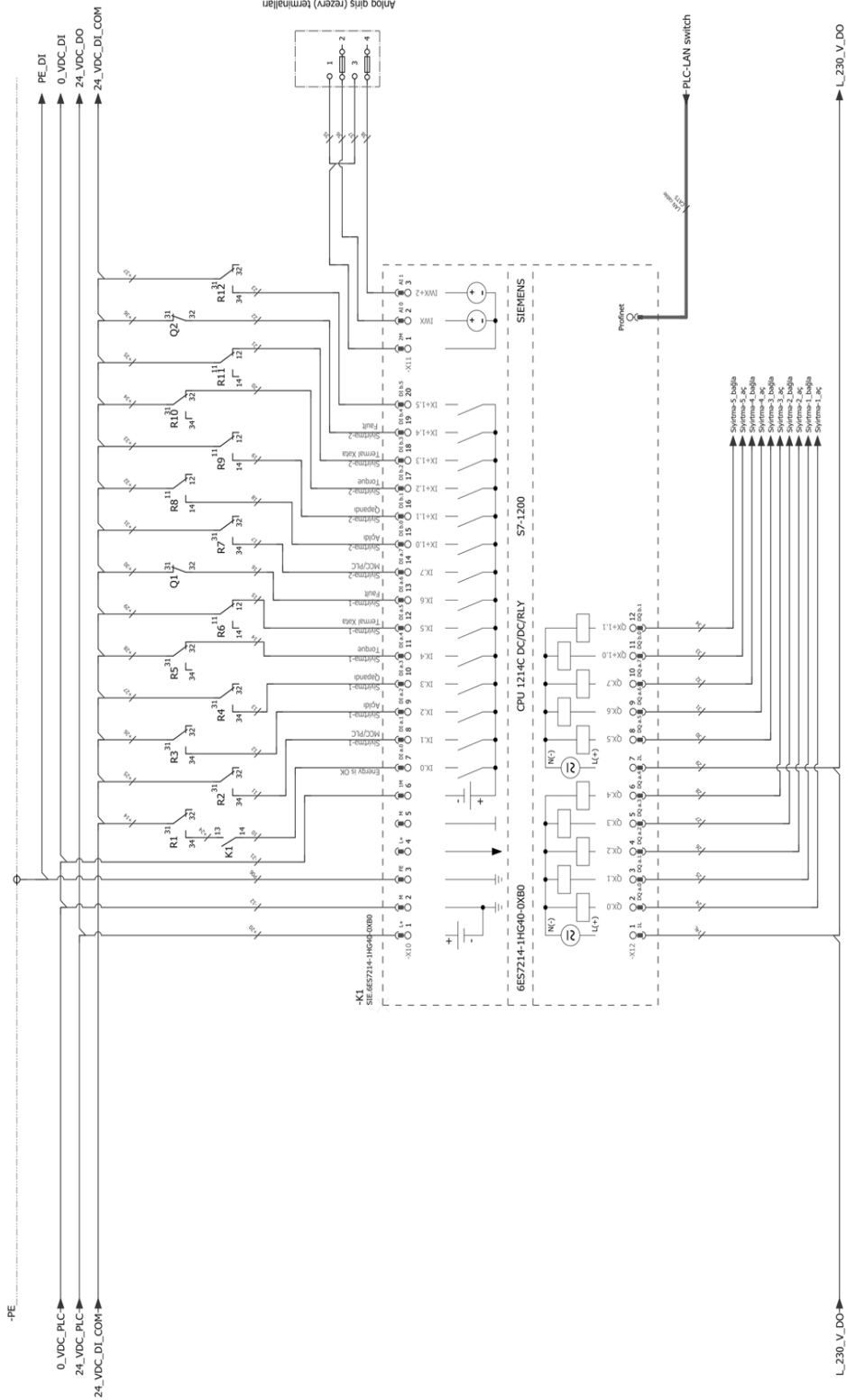

Figure 3. Control panel. Connection diagram with PLC

OPERATION PRINCIPLE OF MICROCONTROLLER BASED CONTROL SYSTEM

We got acquainted with different ways of determining the level. An ultrasound transmitter connected to the controller is one of the devices that can be used for this purpose. The positive aspect of this device is that when measuring the level with its help, we no longer need the parts of the sensor that touch the water, this sensor is a remote measuring sensor. For this we will use the HC-SR04 transmitter adapted to the Arduino controller. Here we will use one Arduino Uno, HC-SR04 sensor, Relay circuit and ULN2003. The HC-SR04 ultrasonic module is a module that can provide non-contact measurement with an accuracy of up to 3 mm in the range of 2 cm to 400 cm. It works on the principle of echolocation.

Here, the Arduino sends a 10 microsecond 10 KHz sound wave to the trigger pin of the sensor, this wave hits the water surface and echoes, and the signal level is received on the echo pin. In this case, the time between the 2 signals plays a key role in measuring the distance. Taking into account that the speed of sound is 340 m/s, the distance is calculated like this.

$Distance = (\text{time}/2) * \text{Speed of sound}$

To determine the water level in the tank, we need to know the total length of the tank. It is this value that will allow us to calibrate the tank. 1 Buzzer is used to signal the circuit when the tank is empty. One of the disadvantages of this method is that if you install this system for a narrow pipe or tank with a small diameter, high-frequency peaks may echo from the walls of the container, causing noise. In this case, our measurement will be wrong. Therefore, the diameter of the container should not be less than 7.5 cm for a half-meter tank.

The structural diagram of the connection of the ultrasound transmitter is given in figure 4.

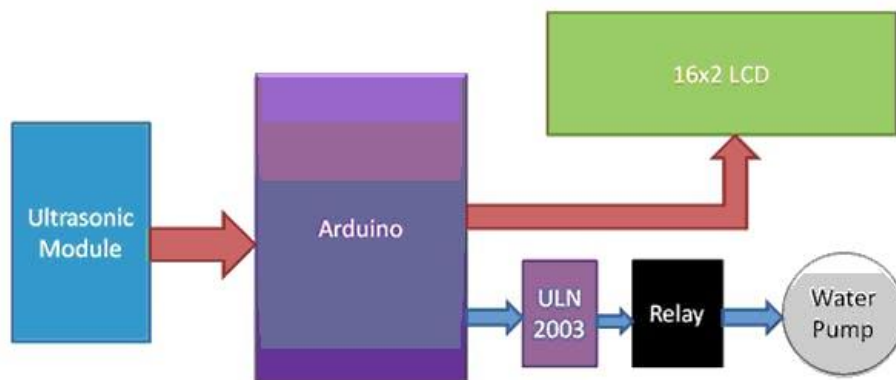

Figure 4. Structural diagram of the connection of the ultrasound transmitter

We can learn the distance with the help of the sensor, and then we convert the distance plot to the level measurement by programming the Arduino:

/* Water Level Meter

Measuring water level with ultrasonic sensor HR S04.

```

*/
int trig = 12;
int echo = 11;
void setup()
{
  Serial.begin(9600);
  pinMode(trig, OUTPUT);
  pinMode(echo, INPUT);
}
void loop()
{
  long t = 0, h = 0, hp = 0;
  digitalWrite(trig, LOW);
  delayMicroseconds(2);
  digitalWrite(trig, HIGH);
  delayMicroseconds(10);
  digitalWrite(trig, LOW);
  t = pulseIn(echo, HIGH);
  h = t / 58;
  h = h - 6; // offset correction
  h = 50 - h; // water height, 0 - 50 cm
  hp = 2 * h; // distance in %, 0-100 %
  Serial.print(hp);
  Serial.print("\n");
  delay(1000);
}

```

When we want to test if our transmitter is working properly, we fill the tank all the way, then open a valve and let the water flow. Inside the Arduino, we will see the function of stepwise discharge of water.

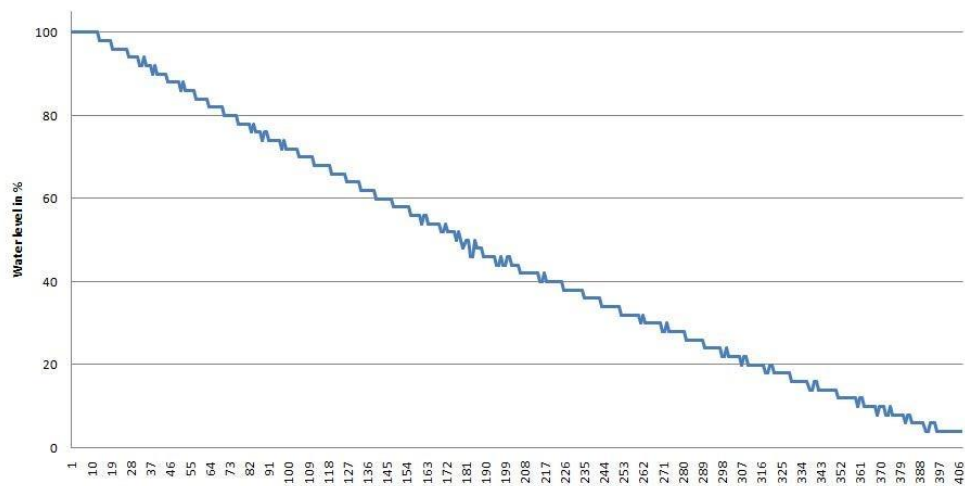
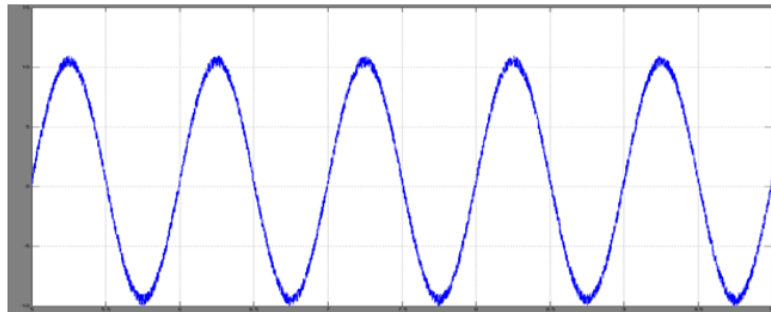

Figure 5. Step discharge function of the ultrasound transmitter

CONTROL OF SYSTEM STUDY AND ACCURACY OF MEASUREMENT RESULTS

Information about human-machine interface modules and measuring devices that allow collecting information about the system was collected, and the question of ensuring the accuracy of the measurement was studied.

During the research, a microcontroller process control system was recommended. A virtual measurement system was recommended, and corrective filtering was introduced to improve the measurement results. For this, simulation modeling was carried out in the LabIEW program and a satisfactory result was obtained. (figure 6).



a)

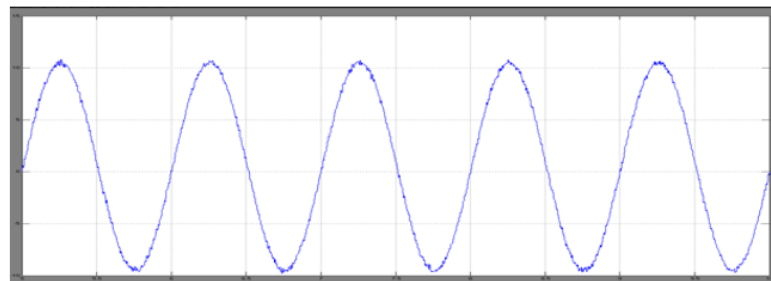

Figure 6. a) The signal given to the input of the filter,
b) the signal received at the output of the filter

CONCLUSION

In conclusion, it should be noted that the microcontroller is an excellent level control device due to its characteristics such as low power consumption, high performance and ADC. The microcontroller can be used with a level sensor for accurate level measurement in various applications. Information is provided on the importance of connecting the level sensor to controllers for remote control, visualization of its data, more accurate operation and

compatibility with systems where processes are automated. The level control system in the warehouses, which is a part of the water supply system, is built according to SCADA control. The general appearance of the system, the principle of work has been studied. The hardware and software that make up the system have been examined.

The electrical circuits of the control panels, which make up the hardware of the system, have been built. The principle of operation of control panels, the joint operation of power, control and weak flow is justified. The software has been studied and the operating program of the PLC has been designed. the SCADA HMI program of the research facility was designed and the working principle was determined.

REFERENCES

1. Bajzek, T. J. (2005). Thermocouples: a sensor for measuring temperature. *IEEE Instrumentation & Measurement Magazine*, 8(1), 35–40.
2. Brogioli, M. C. (2019). Software and Compiler Optimization for Microcontrollers, Embedded Processors, and DSPs. *Software Engineering for Embedded Systems*, 245–267.
3. Devine P. Radar level measurement – the user’s guide. Burgess Hill: VEGA Controls, 2004.-116 P.
4. Jarullah, A.T., Awad, N.A., Mujtaba I.M.. Optimal design and operation of an industrial fluidized catalytic cracking reactor. 2017, 206, 657–674
5. Uddin, M. M., Al Mahmud, A., & Islam, N. (2019). Design & Implementation of a Microcontroller Based Automatic Power Factor Rectification System for Different Loads. 2019 1st International Conference on Advances in Science, Engineering and Robotics Technology (ICASERT).
6. Ukil, A., Braendle, H., & Krippner, P. (2012). Distributed Temperature Sensing: Review of Technology and Applications. *IEEE Sensors Journal*, 12(5) , 885–892.
7. Vinogradova N.A., Listratov Ya.I., Sviridov E.V. Development of application software in the LabVIEW-2007 environment.-30 p.
8. Druzyakin I.G., Lykov A.N. . Technical measurements and devices, 2008. -412 s.
9. Measuring the liquid level with a capacitive level meter: method. Instructions for laboratory work / A.R. Gerke [et al.], 2010 – 16 p.
10. Yusifov S.İ., Mayilov R.A., Mehdiyeva A.M., Mehdizade E.K. Advanced Information-Measuring System for the Improvement of the Quality Indicators of Metrological Characteristics. *E3S Web of Conferences (Environment, Energy and Earth Sciences)*, Vol. 474, 02003 (2024). ISSN: 2267- 1242.
11. Sukhov, E.A., Gurfinkel', L.M., & Popov, Yu.G. (1985). Abstracts of Papers, Conference and Meeting on Hydraulic Engineering. Leningrad: Energoatomizdat.
12. Agayev F.H., Mehdiyeva A.M., Ibrahimova A.E. Advance Technologies to Eliminate Environmental Problems of Oil and Gas Processing. 2nd International Conference on Emerging Applications of Material Science and Technology (ICEAMST 2024), July 3-4, 2024, Bengaluru, India. *Advances in Science, Technology & Innovation*.
13. Kalatuzov, V.A. (2002). *Hydromechanics*. Moscow: Izd. MGTU im. N.E. Bauman.
14. Agayev F.H., Mehdiyeva A.M., Gafarov G.A., Bakhshaliyeva S.V., Shirinzade N.V. Development of the functional safety system in primary oil refining Nafta-Gaz. *Oil and Gas Institute - National Research Institute*. Poland. ISSN 0867-8871. <https://www.inig.pl/en/nafta-gaz-en/available-articles>

15. Sukhov, E.A., Gurfinkel', L.M., & Popov, Yu.G. (1985). Abstracts of Papers, Conference and Meeting on Hydraulic Engineering. Leningrad: Energoatomizdat.
16. Agayev F.H., Mehdiyeva A.M., Ibrahimova A.E. Advance Technologies to Eliminate Environmental Problems of Oil and Gas Processing. 2nd International Conference on Emerging Applications of Material Science and Technology (ICEAMST 2024), July 3-4, 2024, Bengaluru, India. Advances in Science, Technology & Innovation.
17. Kalatuzov, V.A. (2002). Hydromechanics. Moscow: Izd. MGTU im. N.E. Baumana.
18. Agayev F.H., Mehdiyeva A.M., Gafarov G.A., Bakhshaliyeva S.V., Shirinzade N.V. Development of the functional safety system in primary oil refining Nafta-Gaz. Oil and Gas Institute - National Research Institute. Poland. ISSN 0867-8871 <https://www.inig.pl/en/nafta-gaz-en/available-articles>.