

# Design and Implementation of an IOT-Based Cooking Gas Gauging System using STM32F411CEU6 Microcontroller

## ABSTRACT

In Nigeria, many Liquefied Petroleum Gas (LPG) users face two common issues due to their inability to gauge the gas level in cooking cylinders. First, they often get defrauded by either LPG vendors or their assistants, leading to the purchase of less gas than paid for. Second, they experience the inconvenience of running out of gas while cooking, especially during odd hours. To address these problems, this paper introduces an LPG gauging system utilizing the Internet of Things (IoT) technology. Key components of the system include load cells for weight sensing, an HX711 amplifier, and an STM32F411CEU6 microcontroller (MCU) that acts as the central processor of the device. When the load cell detects weight, it sends a signal to the HX711 amplifier, which amplifies the signal, converts it to digital form and then forward it to the MCU for processing. The MCU then triggers the Liquid Crystal Display (LCD), showing the LPG level from the time of purchase until it is depleted. Users can also set a refill reminder to be triggered via SMS and calls when the gas reaches a preset level. Additionally, a custom mobile app has been developed for remote monitoring and control of the LPG cylinder. The system is powered by a battery, a 5V power pack, and an 18W solar panel. Implementing this system will prevent LPG users from being defrauded and will help in avoiding the inconvenience of running out of gas while cooking.

Keywords: Liquefied Petroleum Gas; Internet of Things; LPG gauging; STM32F411CEU6 microcontroller; Load cell; HX711 amplifier.

### 1.0 Introduction

Liquefied Petroleum Gas (LPG), a fuel gas, made primarily from butane, propane [1-2] and unsaturated hydrocarbons [3], is gotten either as a product of refining of petroleum or from the extraction of natural gas [4]. LPG, as a cooking fuel, is bottled and marketed in pressurized cylinders in liquid form [3] and usually filled to about 80% to 85% of its capacity to allow for thermal expansion of the gas [2].

In a world where convenience is key and efficiency paramount, the monitoring of LPG in cooking cylinders stand in the forefront of innovation. As the primary source of cooking fuel for millions of households worldwide, ensuring a seamless gauging of LPG in cooking cylinders is not only essential for daily life but also critical for economic development.

In Nigeria, the inability to gauge the level of LPG in the cooking cylinder is accompanied by two unwholesome scenarios. First, most users are defrauded by the LPG vendor or the ward who is assisting the user to make the purchase. The end up having LPG of a lesser quantity than what they paid for. Second, the scenario of having an empty cylinder while cooking, especially during odd hours, is quite embarrassing. To put an end to this fraud and embarrassment, researchers have designed various systems [5-20]. This section looks into existing literatures, summarize their shortcomings and propose a concept that will bridge the existing gap.

Mariselvam & Dharshini [5] developed an LPG gauging and automatic booking system using an integrated sensor which was developed using a transducer. The sensor, interfaced with the NODE microcontroller (MCU), continuously monitored the level of LPG in the cooking cylinder, transferring same to the MCU. Data received by the MCU was used for decision making, as the MCU triggered to inform the gas vendor to come for a refill when the gas level was low. Oyubuet *et al.*, [6] proposed an LPG gauging system to gauge the quantity of gas in a cooking cylinder and also inform the user and the LPG vendor when the quantity of LPG in the cylinder reaches a preset level via the GSM module which was pivotal to the communication between the system and the user/LPG vendor. The system was designed to prompt LPG level at the following thresholds; low (50%), very low (25%), critically low (12.5%) and empty (6.25%). The Node MCU/Wi-Fi module accepted inputs from the load cell and controlled the output devices based on pre-defined logic. This system could not provide the user with the LPG level after purchase, therefore, failed to handle the fraud scenario that could be perpetuated by either the LPG vendor or the user's ward. Also, the system could not be remotely monitored and controlled. Sabitha *et al.*, [7] developed a system that monitors the weight of the gas in the cooking cylinder. The system was designed such that when the weight of the gas falls below the threshold value of 0.5kg, a logic high

pulse is fed to the microcontroller. As this pin goes high, the microcontroller sends a Short Message Service (SMS) to the user and the gas vendor, requesting for a refill. The disadvantage of the system is that it could not be remotely monitored and controlled. This research aims at deploying the concept of IoT to develop an LPG gauging system, suitable for the monitoring of LPG in the cooking cylinder.

## 2.0 Methodology

This system comprises of the hardware, firmware and software components. For ease of explanation, this section is broken down into various sections for detailed discussion.

### 2.1 Materials

The major materials used for the development of this system's hardware is described below.

**2.1.1 STM32F411CEU6 Microcontroller:** This is a high-performance microcontroller from STMicroelectronics, part of the STM32 family, which is based on the ARM Cortex-M4 core with Floating Point Unit (FPU), running at up to 100MHz. It has a flash memory of 512 kilobyte (KB) and a Static Random Access Memory (SRAM) of 128KB. It operates at a voltage of 1.7V to 3.6V, temperature range of -40 to 85°C and has low power consumption with multiple power-saving modes. This microcontroller is designed to offer high processing power and rich peripheral interfaces, making it suitable for a wide range of applications, ranging from consumer electronics to industrial automation and more.

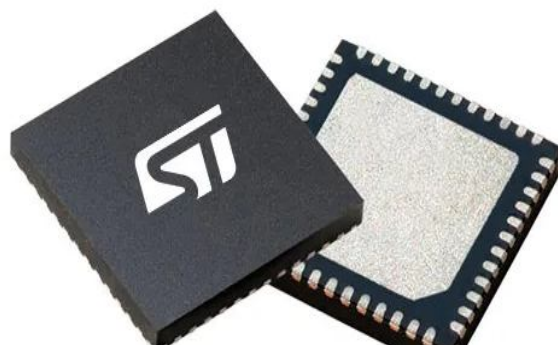

**Figure 1: STM32F411CEU6 Microcontroller**

**2.1.2 HX711 weight sensor amplifier:** This is a precision 24-bit ADC that is designed to amplify signals from the load cell and reporting them to the microcontroller. It contains an on-chip low noise programmable amplifier with an optional gain of 32, 64 and 128. The HX711 chip integrates a regulated power supply, an on-chip clock oscillator, and other peripheral circuits, which have the advantages of high integration, fast response, and strong anti-interference. With the grove I2C connector and 4-pin screw terminal, it becomes quite easy to connect the load cell to the microcontroller, with no soldering required. The HX711 uses a two-wire interface (Clock and Data) for communication. Load cells use a four-wire wheatstone bridge configuration to connect to the HX711. These are commonly coloured and each colour corresponds to the conventional colour coding of load cells: red (Excitation+ or voltage common collector (VCC)), black (Excitation- or GND), white (Amplifier-, Signal- or Output-), green (A+, S+ or O+) and yellow (Shield). The yellow pin acts as an optional input that is not hooked up to the strain gauge but is utilized to ground and shield against external electromagnetic interference. However, some load cells have variations in colour coding. Since the output of the load cell gives a weak signal, the amplifier is used to amplify the signal and to convert the analogue data to digital data by using the ADC [21].

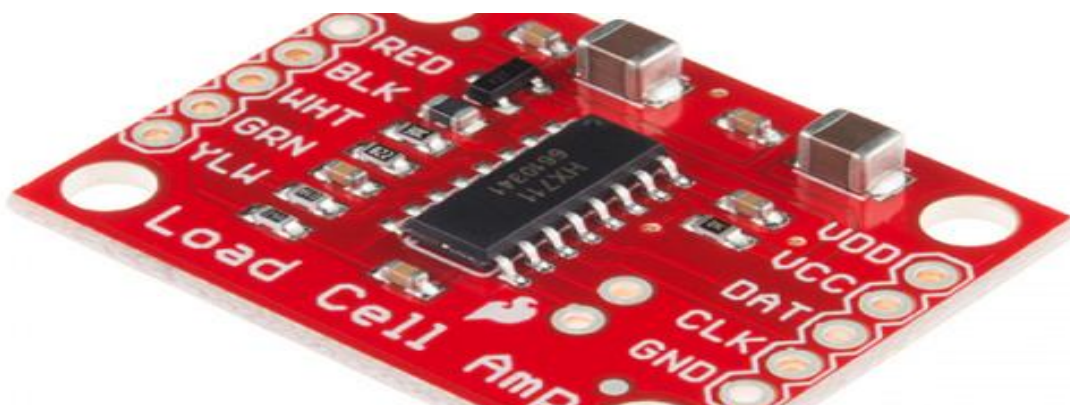

## Figure 2: HX711 weight sensor amplifier

**2.1.3 Load Cell:** A load cell is a non-active transducer or sensor used for measuring weight by converting the applied load into electronic signals. Depending on the circuitry, this signal can appear as a change in current, voltage, or frequency. Load cells utilize strain gauges, which are small resistor patterns that work on the principle of resistance change. When a load is applied, the strain gauges bonded to a deformable beam experience strain, resulting in a change in resistance proportional to the load. Load cells provide highly precise and linear measurements, have excellent fatigue characteristics, and are not significantly affected by environmental changes, although they can be slightly sensitive to temperature variations. They have a long operational life due to the lack of moving parts that generate friction and are easy to produce because of their few components.

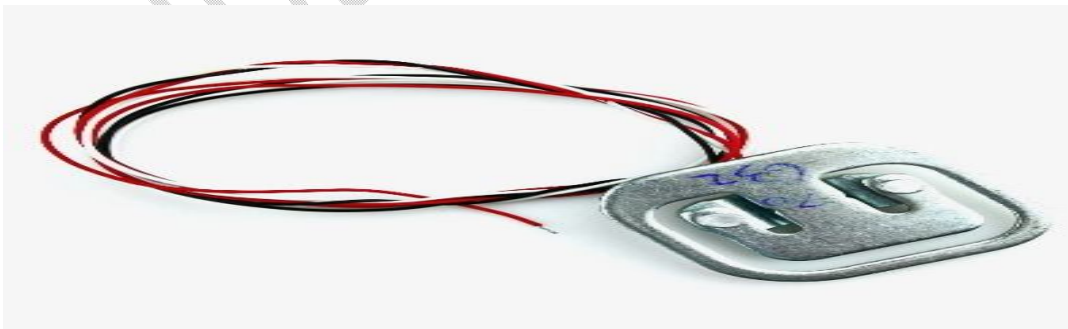
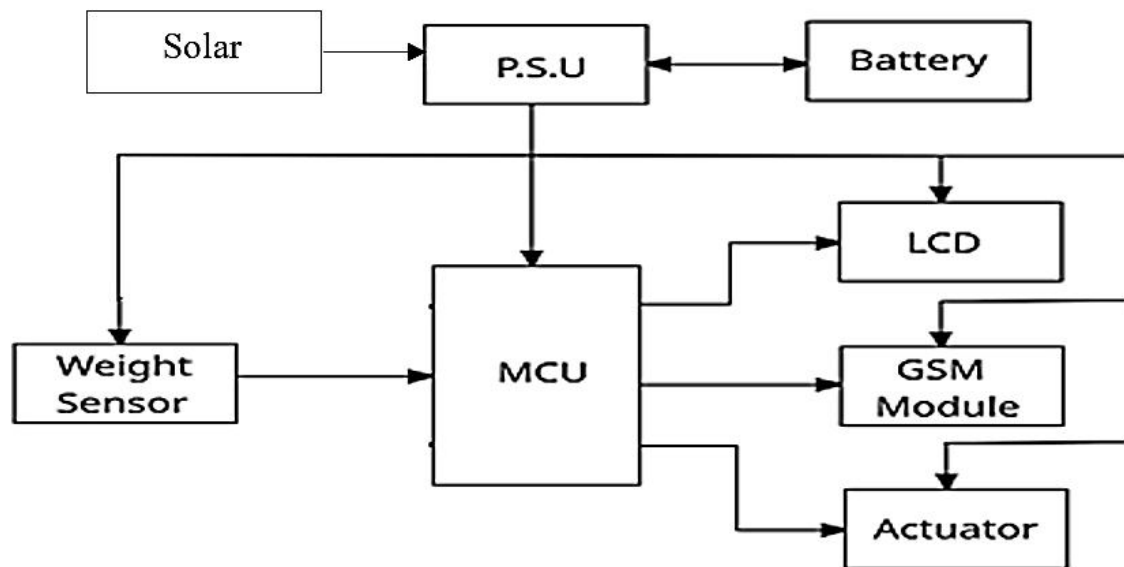

Figure 3: Diagram of a Load Cell

## 2.2 System Design

Figure 4 illustrates the system's block diagram. In this setup, the MCU acts as the central processing unit, overseeing the load cell readings, processing the data, and generating outputs. The input section of the MCU includes a gas weight sensor that detects changes in the weight of the gas cylinder. The output section comprises a driver, a multicolor Liquid Crystal Display (LCD), and a communication module. The driver amplifies the power needed to run the system, the LCD provides a graphical display of the system's status, and the communication module enables internet connectivity, making the device an IoT device.



**Figure 4: Block Diagram of Gas Gauging System**

All hardware components require specific voltage levels as specified in their datasheets. The Power Supply Unit (PSU) handles the conversion of the input voltage into the various voltages needed by the system. The PSU is powered by either a 5V power pack or an 18V solar panel.

### 2.3 System Design/Overview

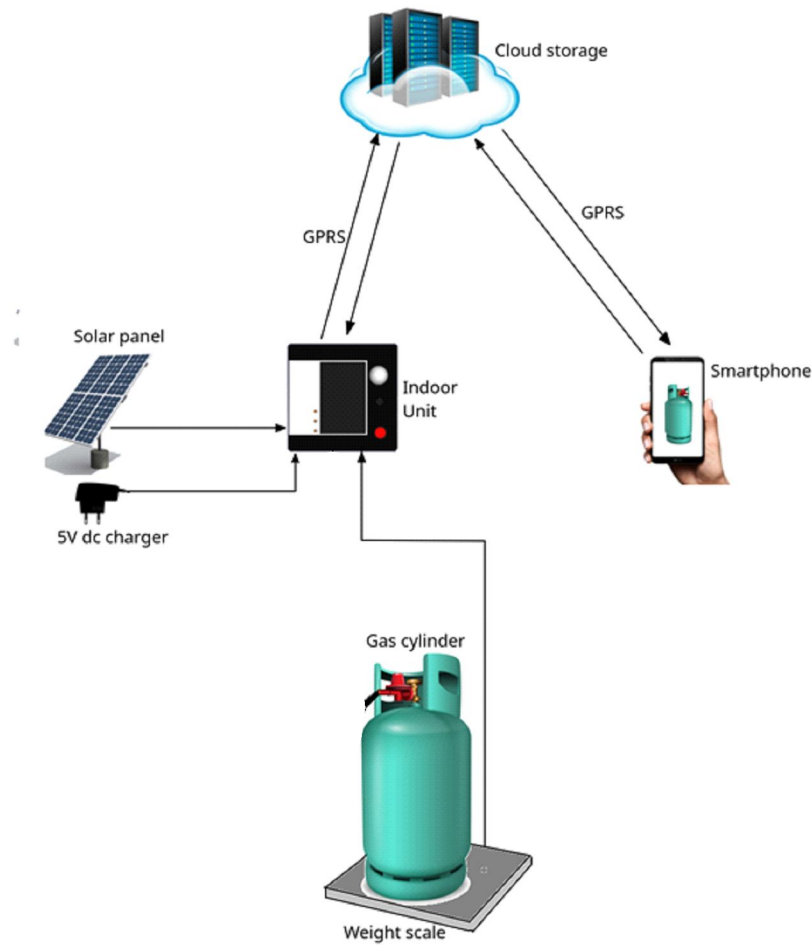
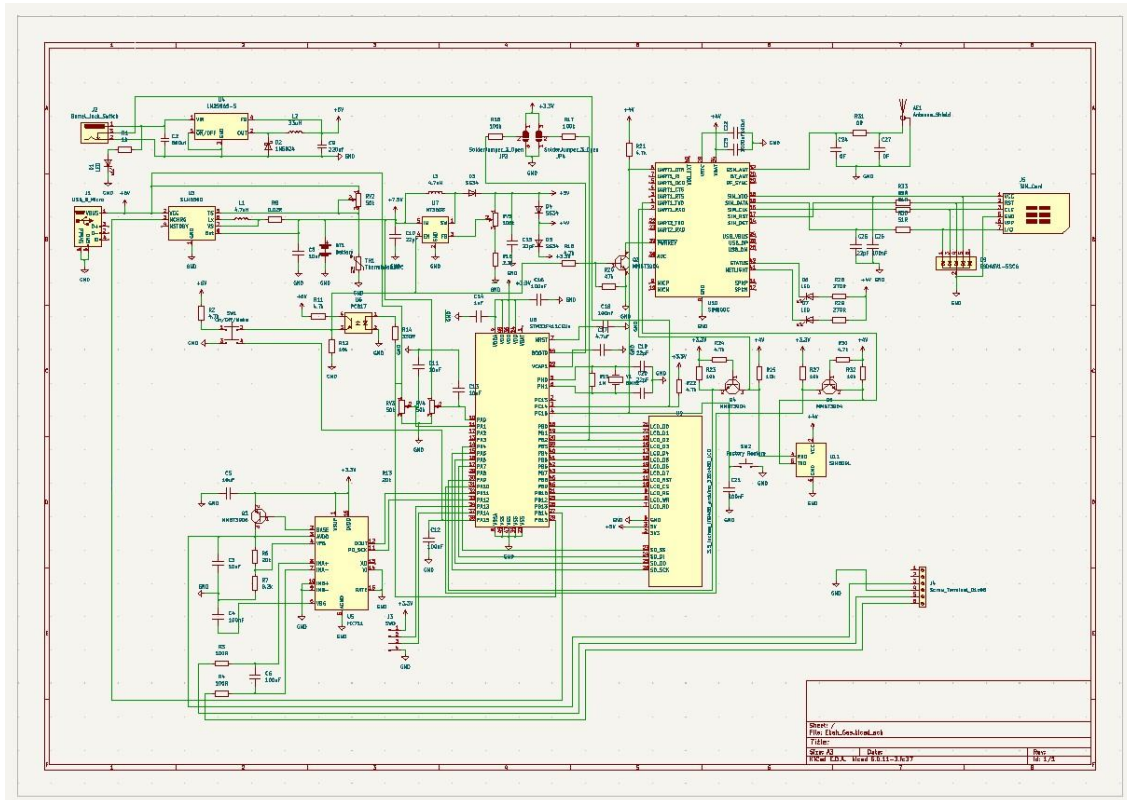

**Figure 5: System Overview**

Figure 5 gives a picture of how the system interacts. The control unit, made up of the HX711 amplifier and the MCU, gathers data from the load cell, controls the charging/discharging of the battery and transmits/receives data to and from the ThingsWeb IoT service. The load cell works by sensing the weight of the gas cylinder. This weight varies with and without content. Using four 50kg load cells, it is possible to create a weight sensor that varies its output current as the cylinder's weight varies. The signal from the load cells, being too low to feed directly to the MCU, is first sent to the amplifier (HX711) which amplifies and sends the amplified signal to the MCU. The MCU reads the signal in digital form, as the amplifier

outputs a pulse train. At the user end, an android smartphone running a custom app is used to monitor, control and manage the system operations remotely.

## 2.4 Circuit Description of LPG Gauging System



**Figure 6: Circuit Diagram of LPG Gauging System**

Components needed were load cell, HX711 load cell amplifier, STM32F411CEU6 microcontroller and jumper wires. The load cell typically has four wires: Excitation+ (E+), Excitation- (E-), Signal+ (S+), and Signal- (S-). The signal from the load cell, being too low to feed directly to the MCU, is first sent to the HX711 amplifier. Connecting the load cell to the HX711, E+ of the load cell is connected to the E+ pin on the HX711, E- of the load cell is connected to the E- pin on the HX711, S+ of the load cell is connected to the A+ pin on the HX711 while S- of the load cell is connected to the A- pin on the HX711.

The signal received by the HX711 is then amplified and forwarded to the MCU. In connecting the HX711 to the STM32 microcontroller, the HX711's VCC is connected to the 3.3V pin on the STM32, the HX711's GND is connected to the GND pin on the STM32, the DT (Data) pin of the HX711 is connected to a GPIO pin on the STM32 (PA11), while the SCK (Clock) pin of the HX711 is connected to another GPIO pin on the STM32 (PA12).

## 2.5 Circuit Analysis of Gauging System

### i. Load cell output voltage

The output voltage is directly proportional to the load applied.

$$\text{Therefore, } V_o = \frac{S \cdot V_e \cdot F_l}{F_m} \quad \text{Equation 1}$$

Where  $V_o$  = output voltage

$V_e$  = excitation voltage

$F_L$  = load applied to the load cell

$F_m$  = Maximum rated force of the load cell = 200kg

$S$  = Sensitivity of load cell in mV/V = 1mV/V

### ii. HX711 amplification of load cell output voltage

$$V_a = G V_o \quad \text{Equation 2}$$

Where  $V_o$  = Output voltage of load cell

$G$  = Gain of the amplifier = 124

$V_a$  = Amplified voltage

### iii. Digital output from HX711 amplifier

$$D = \frac{V_a}{V_s} (2^N - 1) \quad \text{Equation 3}$$

Where  $D$  = Digital output value from HX711

$V_a$  = Amplified voltage

$V_r$  = number of bits for HX711 amplifier = 5V

N = number of bits for HX711 = 24

## **2.6 Firmware Development**

The step-by-step process involved in firmware development are the User Interface (UI) design for the LCD, program plan or flow chart development, sectional code test of the HX711 amplifier, coding of the MCU, debugging and testing.

## **2.7 Development and Testing of the Mobile App**

The development of the mobile app involved the following stages: UI design for the app's layout, flow chart development, sectional code test, coding, debugging, and testing. The actual source code for the mobile app was written in C language.

**2.9 Testing of the Mobile App:** After developing the mobile app, it was tested to evaluate its functionality, performance, and usability. This was done to ensure that the app behaved as expected, and to rectify any issues that may have been overlooked during the app development. Here, the developed app was uploaded and tested on a real device.

## **2.10 Testing and Calibration of the Gauging System**

The load cell was calibrated to measure the weight of the LPG cylinder. The calibration accounted for the weight of the empty cylinder (the minimum limit) and when the cylinder was filled (maximum limit). This was done while the app was running and the calibration was also noted on the app.

In this research, a 12.5 kg was used. With the hardware properly connected, the empty LPG cylinder was set at zero while the full LPG cylinder was set at 12.5 kg. A two-point

calibration was performed. This involved adjusting the readings so that they correspond accurately to the known weights of the empty and full cylinders.

The basic reading code was uploaded to the MCU with zero reading and full reading set to 0. The reading displayed with the empty cylinder on the load cell was recorded as the zero load reading and the value updated to the code. The full LPG cylinder (12.5 kg) was placed on the load cell and the reading displayed was recorded as the full load reading and the value updated to the code. The readings obtained from the empty and full cylinders were used to calculate the scale factor and was been incorporated into the code and updated.

While taking measurement, the load cell was placed on a stable and flat surface, free from vibrations. The load cell's ability to accurately measure the level of LPG in the cylinder and trigger appropriate alerts was then tested and these involved various usage scenarios. The reliability of data transmission from the load cell to the monitoring system was assessed to check for any latency issues or data dropout that could affect near real-time monitoring. Once these was done, the software handled the job from there, notifying and displaying the gas level data.

### **3.0 Results and Discussion**

To monitor the level of gas in the cooking cylinder, the system utilized four 50kg load cells, connected to the control box via connecting cables as seen in figure 8.



Figure 8: Hardware of the Gas Gauging System



Figure 9: Diagram showing gas level on LCD screen

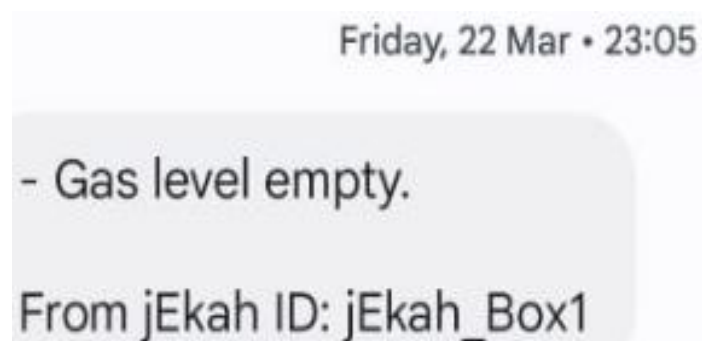

Figure 10: SMS prompt of an empty gas cylinder



**Figure 11: Diagram showing gas level on mobile app**

Figure 9 presents an event where 10.3kg of LPG was topped up to the cooking cylinder. Summing it up, the total LPG in the cylinder was 12.5kg as seen in the LCD screen. Figure 4.10 presents the picture of an SMS received by the user when the cooking gas was empty while figure 4.11 presents the gas level accessed through the mobile app. Here a top-up of 10.5kg was made and 7.46kg of this quantity has been used.

As presented in figures 9, 10 and 11, the system was observed to effectively detect gas levels in the cooking cylinder with high accuracy and reliability and provided timely notifications when the LPG level exceeded the predefined threshold. Hence, the system offers real-time

update to users via the LCD, mobile app and SMS prompts, allowing users to track gas usage and anticipate refills.

## **Conclusion**

An IoT-based LPG gauging system has been developed. Developing the system involved design analysis, circuit construction, firmware development, mobile app development, cloud server setup and integration. The system consists of a load cell linked by cables to the control unit. The control unit consist of the MCU and the battery. The control unit gathers data from the load cell, controls the charging/discharging of the battery and transmits/receives data to and from the ThingsWeb IoT service.

The system is designed such that when the load cell sends the signal to the HX711 amplifier, the HX711 amplifies the signal and sends it to the MCU. The MCU triggers the GSM module to initiate the LPG value on the LCD. This will prevent the user from being defrauded by either the LPG vendor or the ward who is assisting in making the purchase. In addition, the user can adjust the system to a preset level for a refill reminder to be triggered through SMS/call. Owing to this, the system will be triggering a reminder to the user once the LPG gets to a level, as adjusted by the user. This will forestall the embarrassment of having an empty gas while cooking during odd hours.

More so, the system has a custom-developed mobile app that will be used to remotely gauge LPG level in the cooking cylinder at all times. Through this mobile app, gas level notifications will be triggered in the form of beeps to the user.

To arrest the issue of irregular power supply in Nigeria, the system was powered by a battery, a 5V power pack and an 18W solar panel.

## Disclaimer (Artificial intelligence)

Author(s) hereby declare that NO generative AI technologies such as Large Language Models (ChatGPT, COPILOT, etc) and text-to-image generators have been used during writing or editing of manuscripts.

## References

- [1] Pooja. B. M., Sandhya. S. M., Chethan. K. E., Siriparpu, A. & Nagaraj, M. S. (2020). GSM Based Gas Leakage Detection System. *International Journal of Engineering Science and Computing*, 10(6): 26130-26132.
- [2] Belie, O., Mofikoya, B. O., Fadeyibi, I. O., Uguro, A. O., Buari, A., & Ugochukwu, N. N. (2020). Cooking gas explosions as cause of burns among patients admitted to a regional burn centre in Nigeria. *Annals of burns and fire disasters*, 33(1): 62-68.
- [3] Durgalakshmi, K., Kaarthikeyan, A., Muruganandham, S., & Kumar, R. K. (2020). IoT based Gas Level Detection and the Automatic Booking of the Gas. *International Research Journal of Engineering and Technology*, 7(4): 1903-1906.
- [4] Ukpaukure, Y. H., Aimikhe, V., & Ojapah, M. (2023). The Evaluation of Liquefied Petroleum Gas (LPG) Utilization as an Alternative Automobile Fuel in Nigeria. *Open Journal of Energy Efficiency*, 12(1), 1-12.
- [5] Mariselvam, V., & Dharshini, M. S. (2021). IoT based level detection of gas for booking management using integrated sensor. *Materials Today: Proceedings*, 37(2), 789-792.
- [6] Oyubu, O. A., Ikponmwo, O., Kazeem, O. U., Wisdom, O. C., & Nneka, O. J. (2023). Design and Implementation of an IoT Based LPG Management and Distribution System. *SSRG International Journal of Recent Engineering Science*, 10(3): 10-16.
- [7] Sabitha, V., Ragavarthini, S., Roshini, V. & Saranya, T. N. (2020). Automatic Booking System using Internet of Things. *International Journal of Scientific Research and Engineering Development*, 3(2): 287-294.
- [8] Gautam, D., Bhatia, S., Goel, N., Mallikajuna, B., Ganesha, H. S., & Naib, B. B. (2023, March). Development of IoT Enabled Framework for LPG Gas Leakage Detection and Weight Monitoring System. In *2023 International Conference on Device Intelligence, Computing and Communication Technologies, (DICCT)* (pp. 182-187). IEEE.
- [9] Kapadnis, S., Patil, S., Tatar, R., Tatar, L. & Baig, A. (2022). Smart Kitchen using IoT. *International Journal of Advance Research and Innovative Ideas in Education*, 8(3): 2905-2909.
- [10] Madhivathana, S., Malathy, J. & Vasudevan, N. (2020). Gas Level Detection and Automatic Booking using IoT. *International Journal of Advance Research and Innovative Ideas in Education*, 6(2): 550-553.
- [11] Anusuya, A., Kanimozhi, S., Rathna, S. & Sindhuja, S. (2019). Gas leakage Detection and Automatic Gas Booking Alert System using IoT. *International Journal of Engineering Research & Technology*, 7(6): 1-4.

- [12] Palandurkar, V. R., Mascarenhas, S. J., Nadaf, N. D., & Kunwar, R. A. (2020). Smart Kitchen System using IoT. *International Journal of Engineering Applied Sciences and Technology*, 4(11), 378-383.
- [13] Pravallika, K., Lakshmi, T. V., Prasadu, C. N. & Bilal, N. M. (2020). IoT Based Gas Leakage Detection and Booking System for Domestic Applications. *Journal of Engineering Sciences*, 11(2): 922-925.
- [14] Ranjithkumar, K., Preethi, M., K.Sathyadharani, K. & Parveen, J. S. (2021). Detection of LPG Gas Leakage and IoT based Auto Booking System. *International Research Journal on Advance Science Hub*, 3(7): 7-11.
- [15] Srivastava, D., & Varshini, A. (2021). LPG Gas Monitoring and Cylinder Booking Alert System. *International Journal of Progressive Research in Science and Engineering*, 2(5), 12-17.
- [16] Tamizharasan, V., Ravichandran, T., Sowndariya, M., Sandeep, R., & Saravanel, K. (2019, March). Gas level detection and automatic booking using IoT. In *2019 5th International Conference on Advanced Computing & Communication Systems (ICACCS)* (pp. 922-925). IEEE.
- [17] Sai, G. N., Sai, K. P., Ajay, K., & Nuthakki, P. (2023, January). Smart LPG Gas Leakage Detection and Monitoring System. In *2023 5th International Conference on Smart Systems and Inventive Technology (ICSSIT)* (pp. 571-576). IEEE.
- [18] Shah, S., Parashar, A., Rai, C., & Pokhariyal, S. (2021, May). IOT Based Smart Gas Leakage Detection and Alert System. In *Proceedings of the 4th International Conference on Advances in Science & Technology (ICAST2021)*.
- [19] Siddika, A. & Hossain, I. (2018). LPG Gas Leakage Monitoring and Alert System using Arduino. *International Journal of Science and Research*, 9(1): 1734-1737.
- [20] Subbarayudu, P., Latha, B. A., Sree, D. B., Raj, S. P. & Tejesh, H. (2019). Automatic Gas Leak Detection and Prevention using Arduino and GSM Module. *Journal of Emerging Technologies and Innovative Research*, 6(3): 45-49.
- [21] Malipatil, S., Shilpa, B., & Jayasudha, R. LPG Gas Measurement & Detection using GPS. *International Journal of Innovative Technology and Exploring Engineering*, 8(9), 1990-1992.
- [22] Anusha, M., Nagesh, V., Sai, B. V., Srikanth, K. & Nanda, R. (2020). IoT Based LPG Leakage Detection and Booking System with Customer SMS Alerts. *International Journal for Modern Trends in Science and Technology*, 6(1): 1-5.
- [23] Naik, R. N., Reddy, P. S. N., Kishore, S. N. & Reddy, K. T. K. (2016). *IOSR Journal of Electronics and Communication Engineering*, 11(4): 6-12.
- [24] Sudar, K. M., Lokesh, D. L., sihareddy, V. S., Chowdary, Y. C., Kumar, C. H., Nagaraj, P. & Chinnsamy, P. (2021, January). Gas level detection and automatic booking notification using IOT. In *2021 International Conference on Computer Communication and Informatics (ICCCI)* (pp. 1-4). IEEE.

- [25] Chandak, L., Kolhe, A., Shirke, S., Kurumbanshi, S., & Patil, S. (2020). IOT Based LPG Cylinder Monitoring System. *International Journal of Innovative Research in Electronics and Communications*, 7(2): 1-7.

UNDER PEER REVIEW