

Magnetic Field Sensor Network For Pipeline Monitoring Systems

Abstract

*The oil pipeline industry has seen a rise in criminal activities recently. More than \$133b is estimated to be lost globally as a result of the activities of cartels, organized crime members and small-time vandals to oil pipelines. To steal petroleum products from a pipeline, criminals must first drill into the pipeline, (cold or hot tapping) and subsequently weld a new weld piece or screw in an orifice to the pipeline, through which the petroleum product is diverted from the pipeline to another storage. These have crippled the ecosystem, human lives lost and a wide range of poverty in the economy which has motivated this paper to find a lasting solution to the problem at hand. This work employed a magnetic field sensor detector for early detection and petroleum monitoring which is caused by vandals and corrosion that leads to spillage, it will significantly improve productivity, safe lives, improve agricultural products and the ecosystem. The sensor network detects acts of vandalism or corrosion and triggers **real-time alert message** to the operators for actions to be taken, to prevent wide spread of the substance by specifying the spot location of the incidence where the corrosion or spillage took place.*

Keywords: Corrosive, Detection, Leakage, Magnetic Field, Petroleum, Sensor, Spillage

1. Introduction

The use of petroleum spillage model developmental technology in finding the best way of solving oil spill are find in lots of literatures such as vandalism and safety of [1, 2, 3], devices using IoT for detection [4, 5, 6] and for monitoring location [7, 8, 9], which gave rise to motion activation and system resource allocation [10, 11]. This has led to the academia and the industries to collaborate in finding a lasting solution to the economical it has brought to the citizen, these enhances the safety of lives, improving the ecosystem, and infrastructural development.

Real-time pipeline monitoring systems based on wireless sensors have been developed in [12, 13], and they are classified into two types of sensors based on their deployment [14], that is inside or outside the pipeline. Sensors which are inside the pipelines, measure the pressure and the velocity of the oil/water flow, as well as the acoustic vibrations caused by the leakages. Sensors, which are outside the pipelines, measure the temperature, humidity, and properties of the soil around the underground pipelines. The outside sensors are densely buried underground along the pipelines and hence can provide high granularity for leakage detection and localisation [14]. These outside or External sensors use techniques that employ specific sensing devices to monitor pipelines' external parts. These methods can detect leakage occurrence and pipeline surrounding abnormalities. The sensing under these methods typically requires contact with the pipeline surface.

Efforts to monitor pipelines have been ongoing for decades. Various methodologies have been used in attempts to tackle pipeline product theft before this work. For instance, Shoewu et al [15] offered a microcontroller-type alarm system for the detection of pipeline vandals whenever a rubber on the pipe is removed. The microcontroller prompts the authorities into action. The merit of this method is that the sensors are concealed from third parties, but it still

shuts down the pipe operations mechanism upon detection of suspicious human activities. The disadvantage of this method is its high cost of deployment [16].

Obodoze, 2012, [17] offered hardware subsystems to realize a physical test-bed for the oil pipeline vandalism surveillance and monitoring system and a software subsystem to realize the sensor initializations and communication, data transfers a web-based file transfer protocol server, certain email accounts, and cell phone numbers. Because the technology can visually communicate data from a file transfer protocol (FTP) server to an online communication SCADA server, authorities access footage and photographs shot at the scene of oil pipeline vandalism. One drawback is that the framework relies on a solar-powered board to operate the whole device and the camera. As a result, vandals may mistake the presence of the board for a security system. This results in the device being smashed before any vandalism occurs [18]. A trans beneficiary, microcontroller, low-level computing build program, and GSM module for communication, caution, and power supply were the main components of the structure that Abraham (2015) suggested [19]. At the very first evidence of a leak in the pipeline, the system is programmed to sound an alarm and communicate via SMS with the control unit. When considering possible responses, the controller component determines the precise purpose of the spill by using the architecture API.

If vandalism were to occur, the framework ringer would inform the vandals of its careful location, giving them an advantage over the framework [18]. This is the framework's main drawback. As mentioned in [20], their algorithm utilized a light-to-power monitoring approach to identify pipeline breaches. To determine whether a channel had a break, the authors used an appropriate transducer, a light-to-power sensor—specifically, a Light Dependent Resistor—to identify light going through the channel. Their plan worked because they linked each LDR through a resistance splitter configuration. This work's strength is in the precise region it pinpoints as vandalized, which is then sent to the control room for further inquiry. However, its weakness is that it depends on light to detect potential vandalism, therefore it fails to discriminate between day and night vandalism.[18]The authors of [21, 22] first proposed combining transient modelling with leak detection. Functions in the computational model were depending on density as well as pressure. During transient flows, such as pipeline shutdown and start-up, their models enhance the capacity of leak identification. Before pipeline breaks, the upstream and downstream estimates of these stream characteristics remain constant. At the speed of sound, an impulse travels to the two endpoints within the pipeline when an interruption occurs. Each of the three types of sensors—weight, flowmeter, and temperature—provides data on these impacts, including changes in the predicted weight, flow rate, and temperature. A break may be detected, and located, and its size can be calculated in this way by fluctuations from these thermodynamics streaming element. One of the main advantages of the outline is that it enabled live pipeline display, which significantly improved the assessment and examination of breaks across multiple pipeline designs. Its inability to manage massive data sets for either standalone pipelines or intricate networks of pipelines is one of its downsides. [23]Popular pipeline checking systems, such as Distributed Acoustic Sensors (DAS), used to function primarily by listening for audible signals that indicated a little deviance from the protocol [24]. The majority of what is being identified and read is sound, regardless of the innovation used in the finding and the sign processing approach. Their work relied on this fundamental concept; however, it was created with the help of microcontrollers and DTMF technology. The



framework's main flaw is that it doesn't differentiate until the vandals damage the pipeline. Wireless pipeline monitoring devices used in subterranean pipes have encountered a significant power challenge. According to [25], subterranean pipes may use a wave-guide style of wireless communication that has minimal path loss. Despite the drastic reduction in the number of sensor nodes, data is still sent via this method to the ground access point, where it is then sent wirelessly to a control station. To better monitor pipeline systems, the authors of [26] came up with a novel design for fault-tolerant sensor networks. The suggested design incorporates both wired and wireless networking components. When anything goes wrong with the wired portion of the network, the sensor nodes fall back on the wireless portion, which serves as a backup. This design addresses the present problems with wired networks' dependability when it comes to controlling and monitoring pipelines. However, managing the finances of such a project is no picnic. Using a dynamic duty cycle was suggested as a way to reduce energy usage [18]. In calculating the dynamic duty cycle, the radioactive time is expressed as a percentage of the whole cycle period, including both the active and inactive periods. Due to the high-power consumption of needless idle listening, it is common practice in WSN to regularly put the sensor nodes into sleep mode while the network is not in use. The fundamental objective of duty cycling methods is to keep nodes operating in a low-duty cycle state for an extended period. Because they are often unavailable after deployment, monitoring sensor nodes in pipeline monitoring applications are anticipated to have a very long lifespan. One of the most effective ways to lower the power consumption of radio transceivers is by using a duty cycling system. While other metrics for network performance, such as connection and throughput, must remain unaffected, keeping idle listening periods low is no easy feat [27]. Seismic signals produced by different targets are collected by a network of sensors and handling modules installed near the pipeline. In addition, the authors claim in [28] that the model is based on the idea of creating a smart signal processing system through the integration of fiber sensing technology, via the internet signal processing technology, and artificial neural networks for identification. This system can detect soil vibrations around pipelines. We achieved an acceptance rate of 95.3% using the recommended setup. Using an algorithm that can enhance the capabilities of obtaining, preserving, and evaluating pipeline status information, Yu and Guo (2012) [29] were able to increase pipeline efficiency. The technique increased network efficiency in terms of lifetime and data packet latency while using multi-hop, data consolidation, and energy consumption balancing technologies. It also ensured that urgent data packets were uploaded on time.

As a protective covering for the pipeline, Okorodudu et al. [2] showcased a new kind of LCD-wired sensor. The work in this paper is an alternative solution to the one presented there. However, most of the work focuses on detecting metallic tools that humans commonly use for vandalising pipelines which ultimately lead to leakages, rather than focusing on the leak detection itself. Part of the solution relies on some of the literature aforementioned in this section.

In all the work done by the authors, the magnetic field sensor of the X,Y, and Z methodology was not used which gives a better result on location specification of the leak and monitoring of petroleum pipelines.

2. Materials and Methods

The XYZ-Magnetic Model is made up of several magnetic sensors that are arranged in an XYZ pattern along the pipeline. These sensors take readings at predetermined intervals to determine the intensity of the magnetic field, and then they send the information to a central monitoring station. The data is then subjected to an analysis that makes use of sophisticated algorithms to identify variations in magnetic fields that are indicative of the existence of leaks.

| Components and Descriptions | |
|---|--|
| (A) |  |
| Arduino Uno board: The Arduino Uno is a popular microcontroller board based on the ATmega328P chip. It contains digital and analog input/output pins that may be utilized to interface with different sensors, actuators, and other devices. It is commonly used for prototyping and DIY electronics projects. | |
| (B) |  |
| A1302 Linear Hall Effect Sensor: The A1302 is a linear Hall effect sensor that can detect changes in magnetic fields. It outputs an analog voltage signal proportional to the strength of the magnetic field it is exposed to. This sensor is commonly used in applications such as position sensing, current sensing, and proximity detection. | |
| (C) |  |
| QuadBand GPRS-GSM SIM800L: The SIM800L is a Quad-Band GSM/GPRS module that allows devices to communicate over the GSM cellular network. It supports voice calls, SMS messaging, and GPRS data transmission. It is frequently used in IoT devices, GPS trackers, and remote monitoring systems. | |

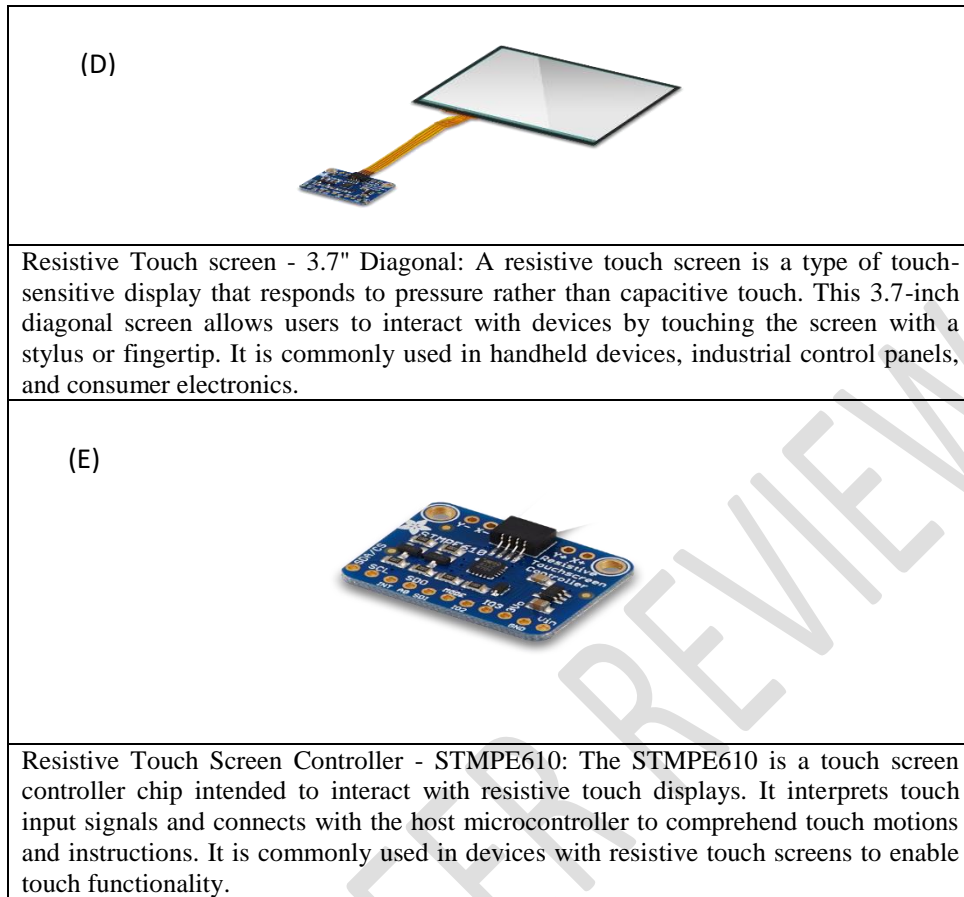

Figure 1 The various components used for the detection of leak, corrosion of the Petroleum Monitoring System

Circuit Connection:

(i.) Connect the three A1302 Linear Hall Effect Sensors to the Arduino Uno board as follows:

- VCC of each sensor to 5V of Arduino Uno
- GND of each sensor to GND of Arduino Uno
- Output of each sensor to analog pins A0, A1, A2 of Arduino Uno

(ii.) Connect the QuadBand GPRS-GSM SIM800L to the Arduino Uno board:

- VCC of SIM800L to 5V of Arduino Uno
- GND of SIM800L to GND of Arduino Uno
- TX of SIM800L to RX pin 7 of Arduino Uno
- RX of SIM800L to TX pin 8 of Arduino Uno

(iii.) Connect the Resistive Touch screen to the Arduino Uno board:

- VCC of touch screen to 5V of Arduino Uno
- GND of touch screen to GND of Arduino Uno
- Data pins of touch screen to respective pins of STMPE610 controller

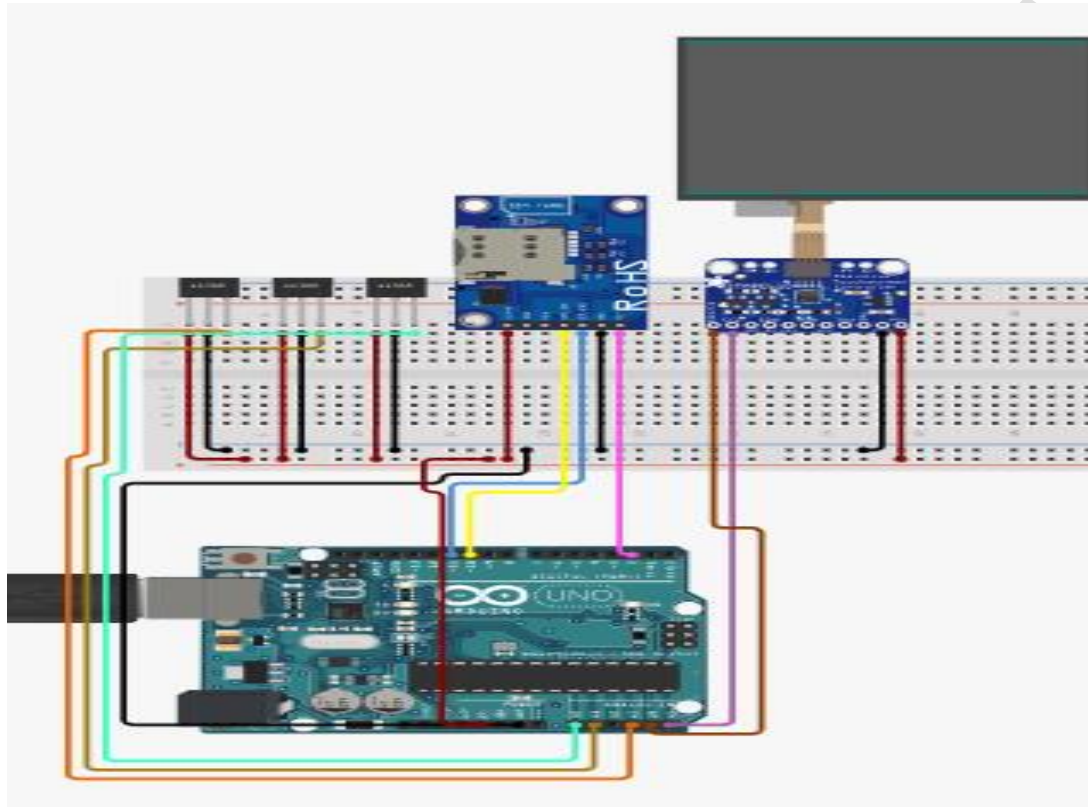

Figure 2 Complete Magnetic field sensor design for Pipeline Monitoring System.

2.1 Methodology

1. Designed a network of magnetic field sensors placed along the pipeline for monitoring purposes. 2. Selected appropriate magnetic field sensors based on sensitivity, range, and communication capabilities. 3. Installed the sensors along the pipeline at regular intervals to ensure comprehensive coverage. 4. Established a communication network between the sensors and a central monitoring system for real-time data collection. 5. Implemented data analysis algorithms that detect anomalies in the magnetic field that may indicate potential issues with the pipeline. 6. Developed a user interface for monitoring and managing the sensor network.

The XYZ-Magnetic Model which is commonly used in geophysics to describe the magnetic field of the Earth was adopted for this research. It is based on the assumption that the magnetic field can be represented as a vector field

that can be decomposed into three components: X, Y, and Z. The X component represents the magnetic field in the north direction, the Y component represents the magnetic field in the east direction, and the Z component represents the magnetic field in the vertical direction.

The mathematical model for the XYZ-Magnetic Model implementation was expressed as follows:

$$B_x = -MV/(r^3) * [3xz - r^2x].....i,$$

$$B_y = -MV/(r^3) * [3yz - r^2y].....ii,$$

$$B_z = MV/(r^3) * [2z^2 - x^2 - y^2].....iii$$

where:

- B_x , B_y , and B_z are the X, Y, and Z components of the magnetic field, respectively
- M is the magnetic moment of the pipe
- V is the volume magnetization of the pipe
- r is the distance between the point of interest and the centre of the pipe
- x, y, and z are the coordinates of the point of interest relative to the centre of the pipe

The XYZ-Magnetic Model can be used to analyze and interpret magnetic field data collected from the Earth's surface or space. By accurately determining the X, Y, and Z components of the magnetic field

3. Results and Discussion

- i. The magnetic field sensor network was successfully deployed along the pipeline with sensors placed strategically.
- ii. Real-time data collection and analysis allowed for detecting anomalies in the magnetic field, such as changes in intensity or direction.
- iii. The monitoring system alerted operators on potential issues with the pipeline, such as corrosion, leaks, or structural damage.
- iv. The utilization of the magnetic field sensor network improved the overall safety and efficiency of the pipeline monitoring system.
- v. The user interface provided operators with an intuitive way to view and manage the sensor network, enabling quick response to any detected issues.

The system outperforms the sound and pressure sensor systems when we compared it using these key areas: detection accuracy, maintenance requirements, and the rate of false positives. It is perfect for long-term operation because of its low maintenance needs and real-time, disruption-free metal alteration detection, especially in remote areas where power efficiency is crucial. It has a 5% false-positive rate, approximately. The magnetic field sensor system provides a more dependable and cost-effective method of pipeline monitoring than pressure sensors, which need to be calibrated often and have high maintenance expenses, or acoustic sensors, which have mediocre accuracy and are easily affected by background noise.

Pressure sensors are very accurate, but they are not recommended for general use in dynamic situations because of their short detection range and constant calibration needs. Case studies demonstrate the efficacy of magnetic field sensor technology in pipeline protection and early spill detection; in Nigeria, for example, reaction times have been slashed by thirty percent. On the other hand, acoustic sensors used by most organizations possess an expanded 500-meter detection range but need extra filtering equipment to improve their performance, and they also struggle with noise interference.

4. Conclusion

The XYZ-Magnetic Model presented in this paper offers a novel approach to pipeline leakage detection using magnetic field sensors. By utilizing a three-dimensional configuration of sensors, the system can accurately detect leaks in pipelines with high accuracy and reliability. The experimental results demonstrate the effectiveness of the XYZ-Magnetic Model in real-time leak detection and monitoring. This research opens up new possibilities for the development of advanced pipeline monitoring systems for improved safety and efficiency.

Disclaimer (Artificial intelligence)

Option 1:

Author(s) hereby declare that NO generative AI technologies such as Large Language Models (ChatGPT, COPILOT, etc.) and text-to-image generators have been used during the writing or editing of this manuscript.

5. References

- [1] Okorodudu FO, Okorodudu PO, Ekerikevwe KI. A model of petroleum pipeline spillage detection system for use in the Niger Delta region of Nigeria. *International Journal of research-Granthaalayah*. 2016;4(6):1-16. <https://doi.org/10.29121/granthaalayah.v4.i12.2016.2385>
- [2] Okorodudu FO, Okorodudu PO, Atumah LO. A Monitoring System for Petroleum Pipeline Vandalism in the Niger Delta Region of Nigeria. 2018;6(6):139-150. <https://doi.org/10.29121/granthaalayah.v6.i6.2018.1359>
- [3] Okorodudu FO. Analysis of Petroleum Spillage Detection Systems Designed for use in the Niger Delta Region of Nigeria: the Missing Link. *International Journal of Research*. 2018;4(1):614–621.

- [4] Okorodudu FO, G. C. Omede (2024) Tracking Soil Moisture Levels and Automated Plant Watering System Utilizing IOT Technology International Journal of Research and Scientific Innovation (IJRSI) ISSN No. 2321-2705 Volume11 Issue 5 Pages 1050-1056 DOI: <https://doi.org/10.51244/IJRSI.2024.1105070>
- [5] Ogini NO, Okorodudu FO (2021) Simplex Algorithm Support System for Optimization of Crop Yield Monitoring System Using Internet of Things (IOT) International Journal of Research and Innovation in Applied Science (IJRIAS) Volume 6 Issue 3 Pages 25-30
- [6] Okorodudu FO, Omede GC, Otegbalor SA, A short Survey On Constructing An Iot-Based Intelligent Road System International Journal of Computer Science & Information Technology (IJCSIT) Vol 14 issue 4, 2022
- [7] Okorodudu FO, Okorodudu PO, Atumah LO, A Novel Approach to Road Traffic Monitoring and Control System International Journal of Multidisciplinary Sciences and Engineering Volume 9 Issue 1, 2018
- [8] Okorodudu FO, Okorodudu PO, Ossai B, A New Approach to Automation and Monitoring in Road Traffic System In Proceedings of the 27th International Conference of the Nigerian Computer Society held at the international conference centre, University of Ibadan from 17th to 19th of July. 2018
- [9] Okorodudu FO, Izakpa GE, ICT-Tools Based Examination Monitoring System; the Delta State University Example 'Ciencia e Tecnica Vitivinicola' journal (ISSN: 2416-3953) Volume 38 Issue n. 1 Pages 45-69, 2023
- [10] Okorodudu FO, Moving Towards Motion Activated Security Camera System With Live Feed and Call Routing. Nigerian Journal of Science and Environment (NJSE), Faculty of Science, Delta State University, Abraka, Nigeria. Vol. 19, Issue 1, Pg 127-139. 2021
- [11] Okorodudu FO, Omede, GC, Mathematical Model for CBT Exam Malpractice Detection System (CEMDS). International Journal of Computer Applications. 186, 21 (May 2024), 1-3. DOI=10.5120/ijca2024923676
- [12] Jawhar I, Mohamed N, Shuaib K. *A Framework for Pipeline Infrastructure Monitoring using Wireless Sensor Networks*, in *Wireless Telecommunications Symposium 2007*, Pomona, CA, USA, April 2007.
- [13] Stoianov I, Nachman L, Madden S. *PIPENET: a wireless sensor network for pipeline monitoring*, in: *Proceedings of the IPSN '07*, Cambridge, MA, USA, April 2007.
- [14] Zhi Sun, Pu Wang, Mehmet C. Vuran, Mznah A. Al-Rodhaan, Abdullah M. AlDhelaan, Ian F. Akyildiz. *MISE-PIPE: Magnetic induction-based wireless sensor networks for underground pipeline monitoring*, *Ad Hoc Networks*. 2011;9(3): 218-227, ISSN 1570-8705, <https://doi.org/10.1016/j.adhoc.2010.10.006>.

- [15] Shoewu O, Akinyemi LA, Ayanlowo KA, Olatinwo SO, Makanjuola NT, et'al. *Development of a Microcontroller Based Alarm System for Pipeline Vandals Detection*. J. Sci. Eng. 2013;1:133–142.
- [16] Bello-Salau H, Aibinu AM, Wang Z, OnumanyiAJ, EN Onwuka, JJ Dukiya et'al. *An optimized routing algorithm for vehicle ad-hoc networks* Engineering Science and Technology, an International Journal. 22(3):754-766
- [17] Obodoeze FC. *Wireless Sensor Network in Niger Delta Oil and Gas Field Monitoring: The Security Challenges and Countermeasures*, Int. J. Distrib. Parallel Syst., 2012;3(6):65–77.
- [18] Salihu O, Aliyu, IO, Agbo SM. Onwuka EN. *MultiSensor Approach for Monitoring Pipelines* Department of Telecommunication Engineering, Federal University of Technology, Minna, Niger State, 234, Nigeria, 2017.
- [19] Abraham I. *Designing an Intelligent Microcontroller based Pipeline Monitoring System with Alarm , Sensor*. vol. 3, no. 2, pp. 22–27, 2015.
- [20] Olunloyo VOS, Ajofoyinbo AM, Yaba A. *“Performance improvement in general packet radio service (GPRS) network based on priority queue oriented admission control* Department of Systems Engineering, Faculty of Engineering Complex University of Lagos Akoka-Yaba, Lagos.
- [21] Oyedeko FK, P. Engineering. *“Modeling and Simulation of a Leak Detection for Oil and Gas Pipelines via Transient Model: A Case Study of the Niger Delta,”* vol. 5, no. 1, pp. 16–28, 2015.
- [22] Yang. *“Research on Leakage Detection and Analysis of Leakage Point in the Gas Pipeline System,”* Open J. Saf. Sci. Technol., vol. 1, no. 3, pp. 94–100, 2011.
- [23] Ononiwu GC, Eze PU, Onojo OJ, Ezeh GN, Dike DO, Igbojiaku SI, NnodiOC, et'al. *“A Real-Time Oil Pipeline Anti-Intrusion System Using Acoustic Sensors,”* vol. 4, no. 26, pp. 3740–3756, 2014.
- [24] Akyildiz IF, Su W, Sankarasubramaniam Y, Cayirci E. *Wireless sensor networks: a survey*, Computer Networks Journal. 2002;38(4):393–422.
- [25] Mohamed N, Jawhar I. *“A fault tolerant wired/wireless sensor network architecture for monitoring pipeline infrastructures,”* Proc. - 2nd Int. Conf. Sens. Technol. Appl., SENSORCOMM 2008, Incl. MESH 2008 Conf. Mesh Networks; ENOPT 2008 Energy Optim. Wirel. Sensors Networks, UNWAT 2008 Under Water Sensors Syst., 2008;179–184.
- [26] Qiu L, Wang WI, Salcic Z. *“Dynamic Duty Cycle-based Wireless Sensor Network for Underground Pipeline Monitoring,”* 2015;116–121.

- [27] Sun J, Wen J. "Research on monitoring and pre-warning system for security of pipelines based on multi-seismic sensors," ICEMI 2009 - Proc. 9th Int. Conf. Electron. Meas. Instruments. 2009;1689–1693.
- [28] Yan H, Shi G, Hao S, Wang Q. "Oil Pipeline Safety Monitoring Method based on Vibration "Signal Analysis and Recognition," 2009 WRI Glob. Congr. Intell. Syst., 2009;200–206.
- [29] Yu H, Guo M. "An efficient oil and gas pipeline monitoring systems based on wireless sensor networks," Inf. Secur. Intell. Control (ISIC), 2012 Int. Conf.. 2012;178–181.

UNDER PEER REVIEW